

## Fresh Living Tip

Enjoy the convenience of buying in bulk but never seem to have enough room? Stock up with this high-capacity refrigerator as your cold companion for added storage space.

## FINISH OPTIONS



# 24" Marvel High-Capacity Refrigerator

MLRE024

### Storage Adaptability

- 5.3 cu. ft. capacity, stores (190) 12-oz cans
- (2) cantilevered, fully adjustable FreshFlo black commercial-grade steel shelves
- Flat interior door allows for full-depth storage

### Cooling Performance

- Dynamic cooling technology delivers rapid cool down, frost-free operation and precise temperature stability
- Proprietary shelving design plus perforated FreshFlo openings allow for cool air to circulate throughout cabinet for temperature consistency from top to bottom
- Thermal-efficient cabinet insulates cooling environment and conserves energy while maximizing capacity
- Sound-buffering design

### Convenient Controls

- Multifunction controls allow you to select a precise temperature from 34° F to 60° F
- Features easy-to-use settings and options

### Fit & Finish

- Elegant midnight black interior and arctic white LED interior lighting
- Reversible door allows for right or left swing for adaptable installation
- Black toe kick adjustable to 4" with leveling legs

### Warranty

- 1-year parts and labor warranty and 5-year sealed system parts warranty



*The Marvel Refrigerator maximizes capacity with adjustable flat shelving that can fit as many as 190 12-oz cans!*

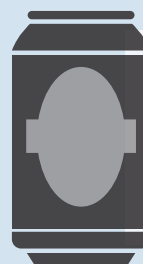

Stores up to  
**190**  
12-ounce cans

#### DOOR STYLE

Solid Stainless Steel

#### MODEL NUMBER

MLRE024-SS01A



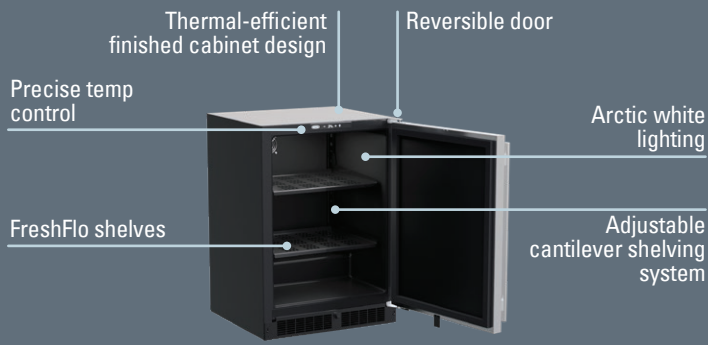

H: 33 3/4" W: 23 7/8" D: 25 21/32" (with handle)

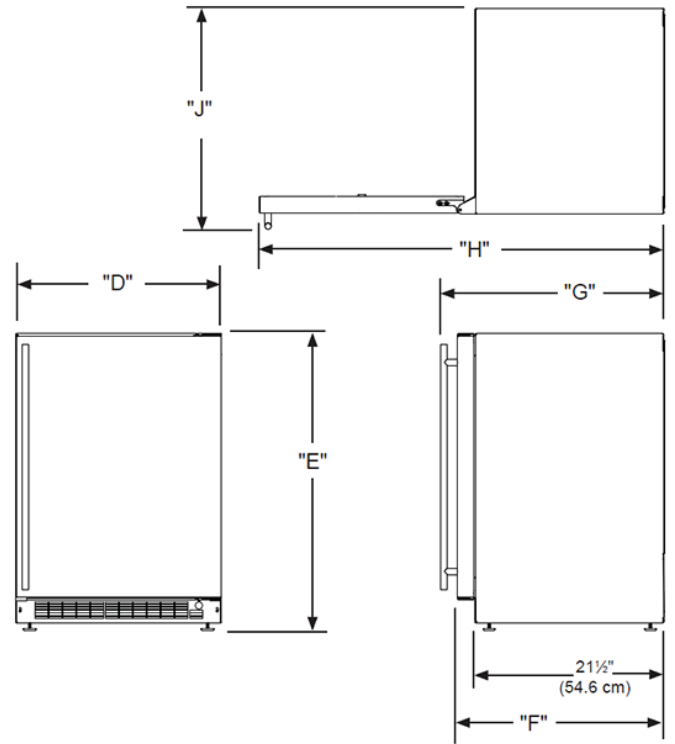
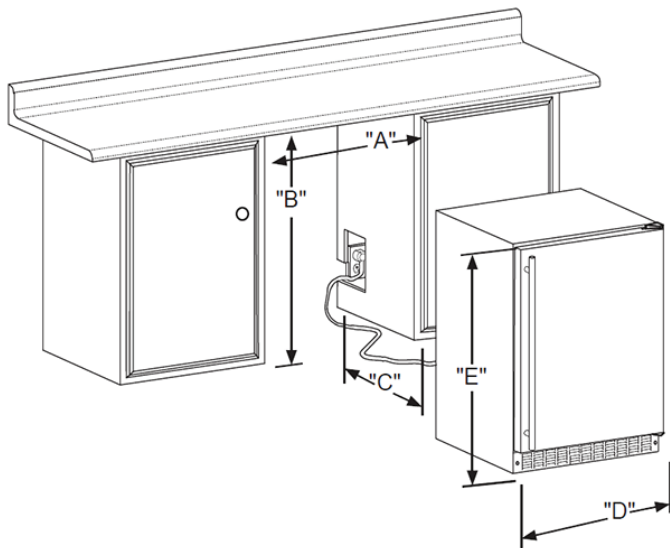

**Rough In Dimensions\***

"A"	"B"	"C"
24"	34-1/4" to 35-1/4"	24"
(61 CM)	(87 CM to 89.5 CM)	(61 CM)

**Cabinet Dimensions\***

"D"	"E"	"F"	"G"	"H"	"J"
23-7/8"	33-5/8" TO 34-5/8"	23-5/8"*	25-21/32"*	47-3/4"*	26-1/2"*
(60.7 CM)	(85.4 CM TO 87.9 CM)	(60 CM)	(65.2 CM)	(146.6 CM)	(67.3 CM)

<b>Capacity</b>	5.3 CU. FT.
<b>Control Type</b>	Electronic
<b>Sabbath Mode</b>	Yes
<b>Temperature Range</b>	34°F to 60°F
<b>Handle Style</b>	Slim
<b>Hinge Type</b>	Reversible
<b>Interior Lighting</b>	White LED
<b>Shelving System</b>	Cantilevered
<b>Toe Grille Finish</b>	Black

<b>Lock</b>	No
<b>Electrical Requirements</b>	115V / 60 Hz / 15A
<b>Cord Length</b>	6 FT.
<b>Shipping Dimensions</b>	28" W x 31" D x 37" H
<b>Shipping Weight</b>	160 LBS
<b>Agency Approval</b>	UL
<b>Refrigerant Type</b>	R600a

For comprehensive installation instructions, please visit [marvelrefrigeration.com](http://marvelrefrigeration.com) to access the owner's guide.

