



Gas Dryer

PRODUCT MODEL NUMBERS

MGDB750Y, MGDB850Y, MGDB950Y

Side view with open door dimensions:

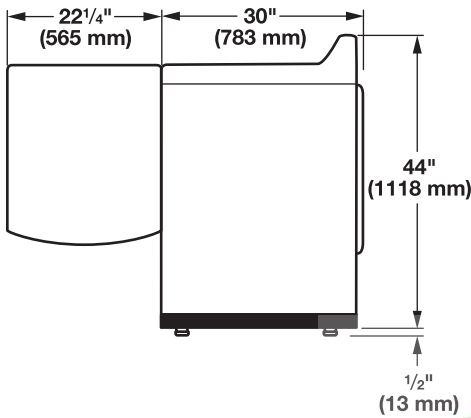

Back view:

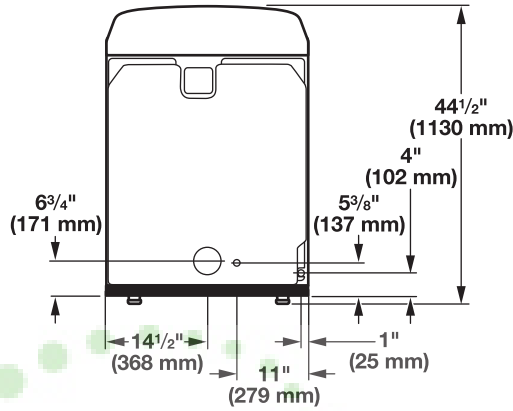

Bottom view:

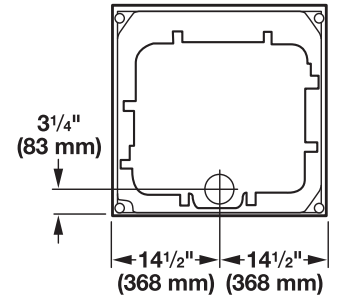

NOTE: Most installations require a minimum 5" (102 mm) clearance behind the dryer for the exhaust vent with elbow. See "Venting Requirements".

Recommended Installation Spacing:

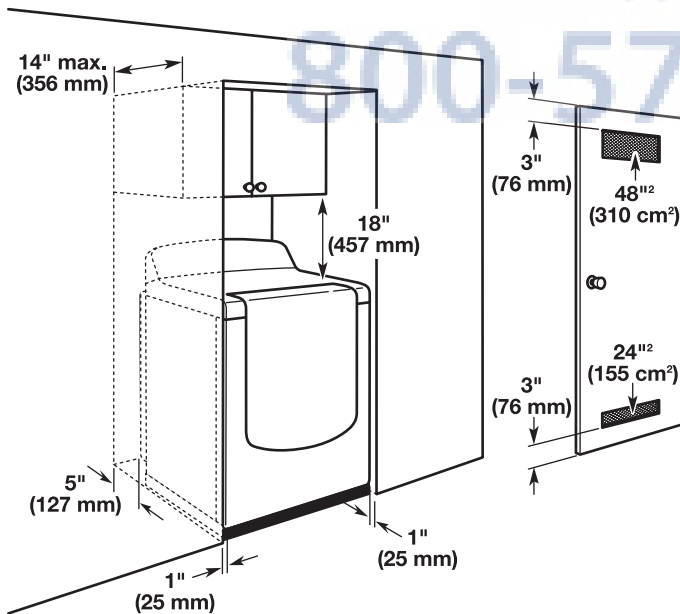

Spacing for recessed area or closet installation

All dimensions show recommended spacing allowed, with tested spacing of 0" (0 mm) clearance on sides and rear.

- Additional spacing should be considered for ease of installation and servicing.
- Additional clearances might be required for wall, door, and floor moldings.
- Additional spacing should be considered on all sides of the dryer to reduce noise transfer.
- For closet installation, with a door, minimum ventilation openings in the top and bottom of the door are required. Louvered doors with equivalent ventilation openings are acceptable.
- Companion appliance spacing should also be considered.

INSTALLATION REQUIREMENTS

GAS SUPPLY REQUIREMENTS

Gas supply: This dryer is equipped for use with Natural gas. Dryer can be converted to L.P. gas. When rigid pipe is used it should be 1/2" IPS. When acceptable to the gas supplier and local codes, 3/8" approved tubing may be used for lengths under 20 ft (6.1 m). For lengths over 20 ft (6.1 m), larger tubing should be used. Pipe-joint compounds resistant to the action of L.P. gas must be used. An individual manual shutoff valve must be installed within 6 ft (1.8 m) of the dryer in accordance with the National Fuel Gas Code ANSI Z223.1.

ELECTRICAL REQUIREMENTS

A 120-volt, 60 Hz, AC-only, 15 or 20 amp fused electrical supply is required. A time-delay fuse or circuit breaker and a separate circuit are recommended.

WATER (STEAM MODELS ONLY) REQUIREMENTS

The dryer must be connected to the cold water faucet using new inlet hoses. Do not use old hoses. Do not overtighten. Damage to the coupling can result.

VENTING REQUIREMENTS

Exhaust venting: Exhaust your dryer to the outside. 4" (102 mm) diameter vent is required. Rigid or flexible metal exhaust vent must be used. Do not use plastic or metal foil vet. Exhaust hood must be at least 12" (305 mm) from the ground or any object that may be in the path of the exhaust.

Exhaust hoods:

Recommended Styles:

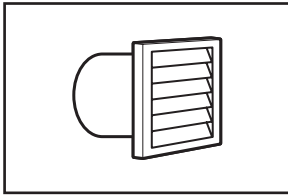

Louvered Hood

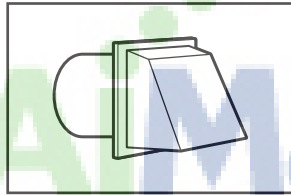

Box Hood

Acceptable Style:

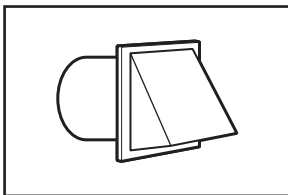

Angled Hood

Determine vent path:

- Select route that will provide straightest and most direct path outdoors.
- Plan installation to use fewest number of elbows and turns.
- When using elbows or making turns, allow as much room as possible.
- Bend vent gradually to avoid kinking.
- Use as few 90° turns as possible.

Determine vent length and elbows needed for best drying performance:

- Use following Vent System Chart to determine type of vent material and hood combinations acceptable to use.

NOTE: Do not use vent runs longer than those specified in Vent System Chart. Exhaust systems longer than those specified will:

- Shorten life of dryer.
- Reduce performance, resulting in longer drying times and increased energy usage.

Maytag Vent System Chart

Number of 90° elbows	Type of vent	Box/louvered hoods	Angled hoods
0	Rigid metal	100 ft. (30.5 m)	94 ft. (28.7 m)
1	Rigid metal	90 ft. (27.4 m)	84 ft. (25.6 m)
2	Rigid metal	80 ft. (24.4 m)	74 ft. (22.6 m)
3	Rigid metal	71 ft. (21.6 m)	65 ft. (19.8 m)
4	Rigid metal	63 ft. (19.2 m)	57 ft. (17.4 m)

NOTE: Bottom exhaust installations have a 90° turn inside the dryer. To determine maximum exhaust length, add one 90° turn to the chart.