

# INSTALLATION MANUAL AIR CONDITIONER

TYPE : WALL MOUNTED  
Original instruction



Copyright © 2017 - 2018 LG Electronics Inc. All Rights Reserved.

P/No : MFL67713861

## TIPS FOR SAVING ENERGY

Here are some tips that will help you minimize the power consumption when you use the air conditioner. You can use your air conditioner more efficiently by referring to the instructions below:

- Do not cool excessively indoors. This may be harmful for your health and may consume more electricity.
- Block sunlight with blinds or curtains while you are operating the air conditioner.
- Keep doors or windows closed tightly while you are operating the air conditioner.
- Adjust the direction of the air flow vertically or horizontally to circulate indoor air.
- Speed up the fan to cool or warm indoor air quickly, in a short period of time.
- Open windows regularly for ventilation as the indoor air quality may deteriorate if the air conditioner is used for many hours.
- Clean the air filter once every 2 weeks. Dust and impurities collected in the air filter may block the air flow or weaken the cooling / dehumidifying functions.

## For your records

Staple your receipt to this page in case you need it to prove the date of purchase or for warranty purposes. Write the model number and the serial number here:

Model number : \_\_\_\_\_  
Serial number : \_\_\_\_\_  
You can find them on a label on the side of each unit.  
Dealer's name : \_\_\_\_\_  
Date of purchase : \_\_\_\_\_

## IMPORTANT SAFETY INSTRUCTIONS

### READ ALL INSTRUCTIONS BEFORE USING THE APPLIANCE.

Always comply with the following precautions to avoid dangerous situations and ensure peak performance of your product.

#### WARNING

It can result in serious injury or death when the directions are ignored.

#### CAUTION

It can result in minor injury or product damage when the directions are ignored.

#### WARNING

- Installation or repairs made by unqualified persons can result in hazards to you and others.
- Air conditioner shall be installed in accordance with national wiring regulations.
- If the supply cord is damaged, it must be replaced by the manufacturer, its service agent or similarly qualified persons in order to avoid a hazard.
- The information contained in this manual is intended for use by a qualified service technician familiar with safety procedures and equipped with the proper tools and test instruments.
- Failure to carefully read and follow all instructions in this manual can result in equipment malfunction, property damage, personal injury and/or death.
- When the power cord is to be replaced, replacement work shall be performed by authorized personnel only using only genuine replacement parts.
- Air conditioner shall be disconnected from its power source during service and when replacing parts.
- Installation MUST conform with local building codes or, in the absence of local codes, with the National Electrical Code NFPA 70/ANSI C1-1003 or current edition and Canadian Electrical Code Part I CSA C22.1.

#### Installation

- Always perform grounding.
- Otherwise, it may cause electrical shock.
- Don't use a power cord, a plug or a loose socket which is damaged.
- Otherwise, it may cause a fire or electrical shock.
- For installation of the product, always contact the service center or a professional installation agency.
- Otherwise, it may cause a fire, electrical shock, explosion or injury.
- Securely attach the electrical part cover to the indoor unit and the service panel to the outdoor unit.
- If the electrical part cover of the indoor unit and the service panel of the outdoor unit are not attached securely, it could result in a fire or electrical shock due to dust, water, etc.
- Always install an air leakage breaker and a dedicated switching board.
- No installation may cause a fire and electrical shock.
- Do not keep or use flammable gases or combustibles near the air conditioner.
- Otherwise, it may cause a fire or the failure of product.
- Ensure that an installation flame of the outdoor unit is not damaged due to use for a long time.
- It may cause injury or an accident.
- Do not disassemble or repair the product randomly.
- It will cause a fire or electrical shock.
- Do not install the product at a place that there is concern of falling down.
- Otherwise, it may result in personal injury.

- Use caution when unpacking and installing.
- Sharp edges may cause injury.
- Thickness of copper pipes used are as shown "Flaring work" Table.
- Never use copper pipes thinner than that in the table even when it is available on the market
- Do not use copper pipes having a collapsed.
- Otherwise, the expansion valve or capillary tube may become blocked with contaminants.
- For R410A model, use piping, flare nut and tools which is specified for R410A refrigerant.
- Using of (R22) piping, flare nut and tools may cause abnormally high pressure in the refrigerant piping, and possibly result in explosion and injury.
- It is desirable that the amount of residual oil less than 40 mg/10m.
- If air enters the refrigerant system, an excessively high pressure results, causing equipment damage or injury.
- Always check for gas (refrigerant) leakage after installation or repair of product. Low refrigerant levels may cause failure of product.
- Ensure that you grab the chassis when you lift the unit.
- If you lift the unit with the panel held, it may result in serious injury or product failure.
- Do not turn on the breaker or power under condition that front panel, cabinet, top cover, control box cover are removed or opened.
- Otherwise, it may cause fire, electric shock, explosion or death.
- Make the connections securely so that the outside force of the cable may not be applied to the terminals.
- Inadequate connection and fastening may generate heat and cause a fire.
- After pump down, power must be turned off before removing the pipe.
- When operating this product without connecting the pipe, there will be high pressure inside the compressor due to the entry of air, possibly causing explosion or injury.
- If the air conditioner is installed in a small room, measures must be taken to prevent the refrigerant concentration from exceeding the safety limit when the refrigerant leaks.
- Consult the dealer regarding the appropriate measures to prevent the safety limit from being exceeded. Should the refrigerant leak and cause the safety limit to be exceeded, hazards due to lack of oxygen in the room could result.
- Use a vacuum pump or inert (nitrogen) gas when doing leakage test or air purge. Do not compress air or oxygen and do not use flammable gases.
- Otherwise, it may cause fire or explosion. There is the risk of death, injury, fire or explosion.

#### Operation

- Do not share the outlet with other appliances.
- It will cause an electric shock or a fire due to heat generation.
- Do not use the damaged power cord.
- Otherwise, it may cause a fire or electrical shock.
- Do not modify or extend the power cable.
- Scratches or peeling insulation on the power cables may result in fire or electric shock, and should be replaced.

- Take care so that the power cord may not be pulled during operation.
- Otherwise, it may cause a fire or electrical shock.

- Unplug the unit if strange sounds, smell, or smoke comes from it.
- Otherwise, it may cause electrical shock or a fire.
- Keep the flames away.
- Otherwise, it may cause a fire.
- Take the power plug out if necessary, holding the head of the plug and do not touch it with wet hands.
- Otherwise, it may cause a fire or electrical shock.
- Do not use the power cord near the heating tools.
- Otherwise, it may cause a fire and electrical shock.
- Do not open the suction inlet of the indoor/outdoor unit during operation.
- Otherwise, it may electrical shock and failure.
- Do not allow water to run into electrical parts.
- Otherwise, it may cause the failure of machine or electrical shock.
- Hold the plug by the head when taking it out.
- It may cause electrical shock and damage.
- Never touch the metal parts of the unit when removing the filter.
- They are sharp and may cause injury.
- Do not step on the indoor/outdoor unit and do not put anything on it.
- It may cause an injury through dropping of the unit or falling down.
- Do not place a heavy object on the power cord.
- Otherwise, it may cause a fire or electrical shock.
- When the product is submerged into water, always contact the service center.
- Otherwise, it may cause a fire or electrical shock.
- Take care so that children may not step on the outdoor unit.
- Otherwise, children may be seriously injured due to falling down.

#### CAUTION

- Install the drain hose to ensure that drain can be securely done.
- Otherwise, it may cause water leakage.
- Install the product so that the noise or hot wind from the outdoor unit may not cause any damage to the neighbors.
- Otherwise, it may cause dispute with the neighbors.
- Always inspect gas leakage after the installation and repair of product.
- Otherwise, it may cause the failure of product.
- Keep level parallel in installing the product.
- Otherwise, it may cause vibration or water leakage.

#### Operation

- Avoid excessive cooling and perform ventilation sometimes.
- Otherwise, it may do harm to your health.
- Use a soft cloth to clean. Do not use wax, thinner, or a strong detergent.
- The appearance of the air conditioner may deteriorate, change color, or develop surface flaws.
- Do not use an appliance for special purposes such as preserving animals, vegetables, precision machine, or art articles.
- Otherwise, it may damage your properties.
- Do not place obstacles around the flow inlet or outlet.
- Otherwise, it may cause the failure of appliance or an accident.
- Features may change according to the type of model.

## Fixing Installation Plate

The wall you select should be strong and solid enough to prevent vibration

- 1 Mount the installation plate on the wall with type "A" screws. If mounting the unit on a concrete wall, use anchor bolts.
- Mount the installation plate horizontally by aligning the centerline using Horizontal meter.

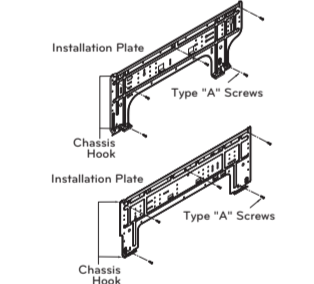

## Drill a Hole in the Wall

Drill the piping hole with a Ø2.9/16" hole core drill. Drill the piping hole at either the right or the left with the hole slightly slanted to the outdoor side.

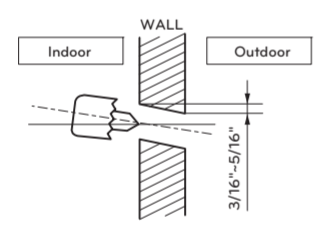

## Flaring Work

Main cause for gas leakage is due to defect of flaring work. Carry out correct flaring work in the following procedure.

- 1 Use the piping kit accessory or the pipes purchased locally.
- 2 Measure the distance between the indoor and the outdoor unit.
- 3 Cut the pipes a little longer than measured distance.
- 4 Cut the cable 4.9 ft longer than the pipe length.

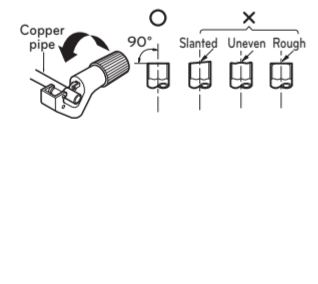

#### NOTE

- To protect the chassis cover bent, assembly chassis cover correctly.

## Burrs removal

- 1 Completely remove all burrs from the cut cross section of pipe/tube
- 2 While removing burrs put the end of the copper tube/pipe in a downward direction while removing burrs location is also changed in order to avoid dropping burrs into the tubing.

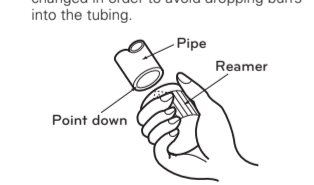

## Putting nut on

- Remove flare nuts attached to indoor and outdoor unit, then put them on pipe/tube having completed burr removal. (not possible to put them on after finishing flare work)

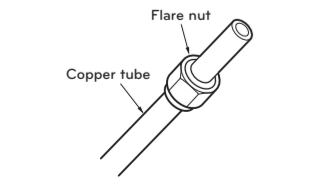

## Check

- 1 Compare the flared work with the figure by.
- 2 If a flared section is defective, cut it off and do flaring work again.

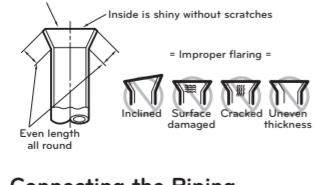

## Connecting the Piping

- 1 Pull the cover at the bottom of the indoor unit.
- 2 Remove the cover from the indoor unit.

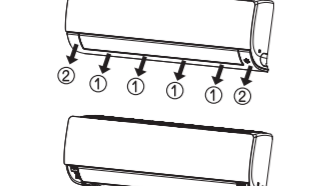

## Flaring work

- 1 Firmly hold copper pipe in a bar with the dimension shown in below table.
- 2 Carry out flaring work with the flaring tool.

Pipe diameter Inch (mm)	Wing nut type	Clutch type
014 (06.35)	0.04-0.07 (1.1-1.8)	0-0.02 (0-0.5)
038 (09.52)		
012 (012.7)		
058 (015.88)		

- 3 Pull back the tubing holder.
- 4 Remove pipe port cover and positioning the tubing

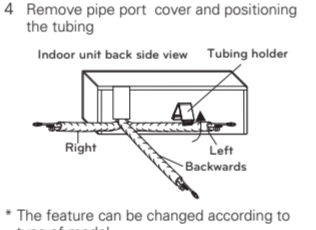

#### NOTE

- The feature can be changed according to type of model.

#### Assembly of chassis cover

- 1 Insert 4 hooks of the chassis cover into gap of the chassis certainly.

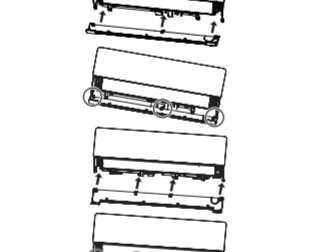

#### NOTE

- To protect the chassis cover bent, assembly chassis cover correctly.

#### Good case

- Press on the tubing cover and unfold the tubing to downward slowly. And then bend to the left side slowly.



#### NOTE

- The feature can be changed according to type of model.

#### Bad case

- Following bending case from right to left directly may cause damage to the tubing.

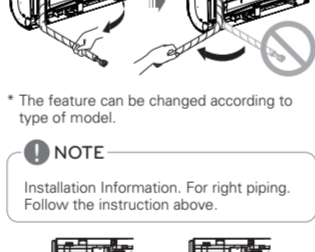

#### NOTE

- Installation Information. For right piping. Follow the instruction above.

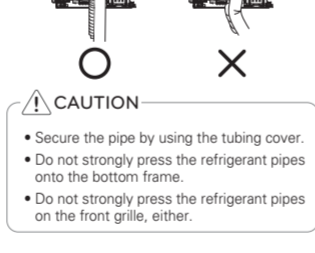

#### CAUTION

- Secure the pipe by using the tubing cover.
- Do not strongly press the refrigerant pipes onto the bottom frame.
- Do not strongly press the refrigerant pipes on the front grille, either.

## Installation of Indoor Unit

- 1 Hook the indoor unit onto the upper portion of the installation plate (engage the three hooks at the top of the indoor unit with the upper edge of the installation plate). Ensure that the hooks are properly seated on the installation plate by moving it left and right

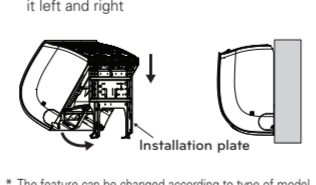

#### NOTE

- The feature can be changed according to type of model.

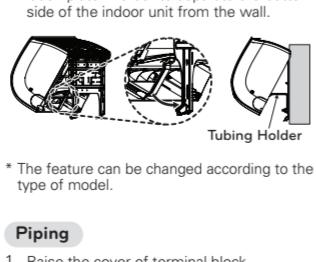

## Piping

- 1 Raise the cover of terminal block.
- 2 Insert the connecting cable through the bottom side of indoor unit and connect the cable. (You can see detail contents in "Connecting the cables" section.)
- 3 Secure the cable onto the control board with the cable retainer.
- 4 Tape the tubing pipe, drain hose and the connection cable. Be sure that the drain hose is located at the lowest side of the bundle. Locating at the upper side can cause overflow from the drain pan through the inside of the unit.

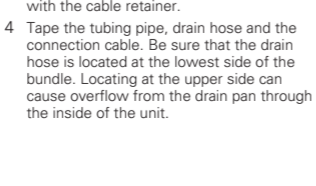

#### <Left side piping>

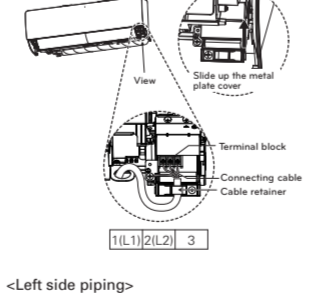

#### <Left side piping>

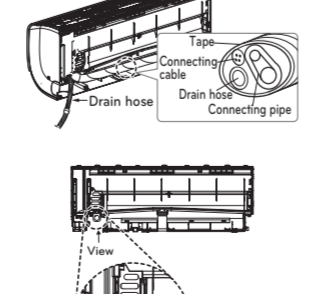

#### NOTE

- Insert the drain hose at left side when you use left side piping type.

#### NOTE

- The feature can be changed according to type of model.

## INTRODUCTION

### Symbols used in this Manual

- ⚠ This symbol alerts you to the risk of electric shock.
- ⚠ This symbol alerts you to hazards that may cause harm to the air conditioner.
- ! This symbol indicates special notes.

### Features

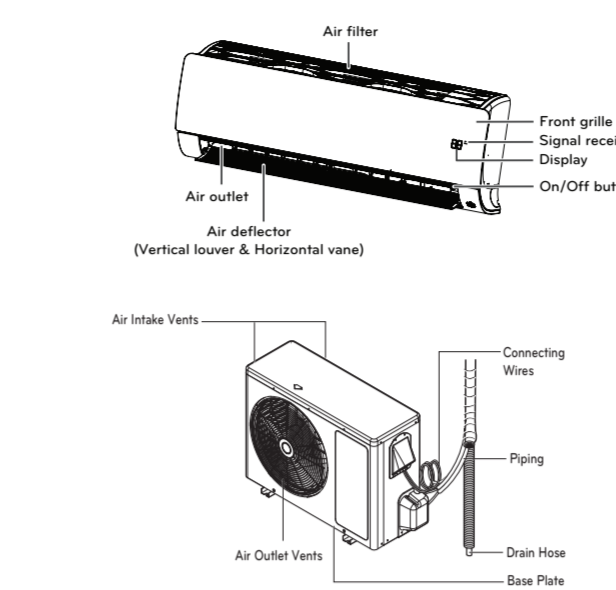

- \* The feature can be changed according to type of model.

## INSTALLATION PARTS

Name	Quantity	Shape
Installation plate	1 EA	
Type "A" screw	5 EA	
Type "B" screw	2 EA	
Type "C" screw	2 EA	
Type "D" screw	2 EA	
Bracket	1 EA	
Remote control holder	1 EA	Type "B" screw
Cloth tape	1 EA	
Connector	3EA (18k,24k)	18k,24k: ⌀ 3/8 in. → ⌀ 1/2 in. ⌀ 5/8 in. → ⌀ 1/2 in. ⌀ 3/8 in. → ⌀ 1/4 in.
Terminal	1EA	

Screws for fixing panels are attached to decoration panel. When indoor unit (18/24k) is connected to the Multi Outdoor unit, use the connector.

## INSTALLATION TOOLS

Figure	Name	Figure	Name
	Screw driver		Multi-meter
	Electric drill		Hexagonal wrench
	Measuring tape, Knife		Ammeter
	Hole core drill		Gas-leak detector
	Spanner		Thermometer, Level
	Torque wrench		Flaring tool set

#### <Right side piping>

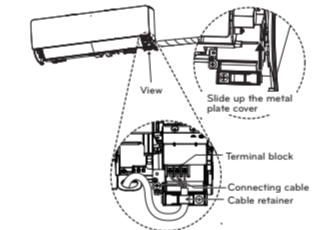

#### NOTE

- The feature can be changed according to type of model.

#### <Right side piping>

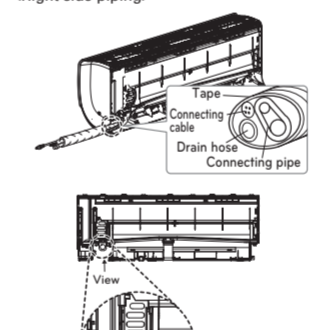

#### NOTE

- The feature can be changed according to type of model.

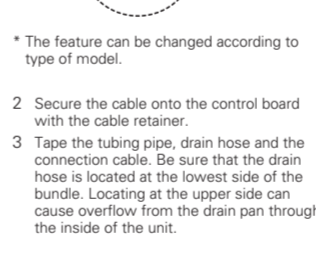

#### NOTE

- Insert the drain hose at left side when you use left side piping type.

## Connecting the installation pipe and drain hose to the indoor unit.

- 1 Align the center of the pipes and sufficiently tighten the flare nut by hand

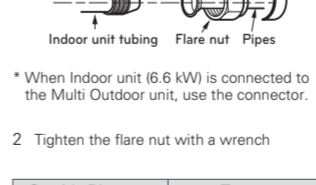

#### NOTE

- When Indoor unit (6.6 kW) is connected to the Multi Outdoor unit, use the connector.

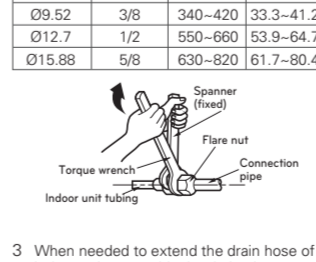

#### NOTE

- The feature can be changed according to type of model.

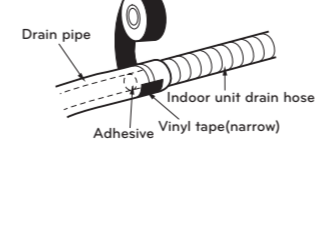

#### NOTE

- Wrap the piping of the indoor unit that are visible from the outside with vinyl tape.

## INSTALLATION MAP

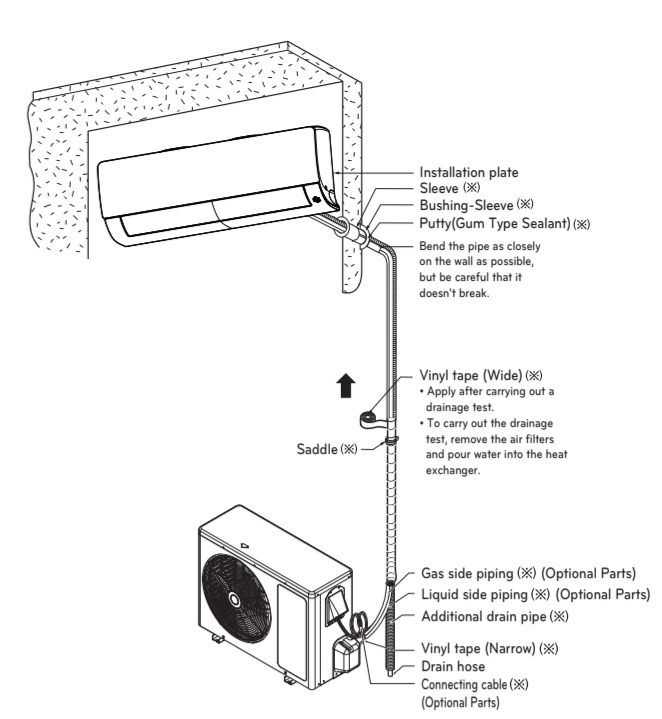

- \* The feature can be changed according a type of model.
- \* Work to the vinyl tape should up from below.

#### NOTE

- You should purchase the installation parts. (It can be changed according to market)

## INSTALLATION

### Select the best Location

- There should not be any heat or steam near the unit.
- Select a place where there are no obstacles around of the unit.
- Make sure that condensation drainage can be conveniently routed away.
- Do not install near a doorway.
- Ensure that the interval between a wall and the left (or right) of the unit is more than 4 in. The unit should be installed as high as possible on the wall, allowing a minimum of 8 in. from ceiling.
- Use a metal detector to locate studs to prevent unnecessary damage to the wall.

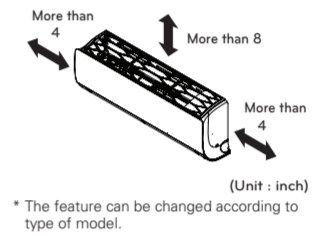

#### NOTE

- The gap between the indoor unit and ceiling is needed more than 8 in. for disassemble the air filter.

#### NOTE

- Remove obstructions to prevent blockage of airflow path.

### Outdoor unit

- 1 Where there are obstacles on both suction and discharge sides (discharge side obstacle is lower than the outdoor unit).
- 2 Where there are obstacles above, and on both suction and discharge sides (discharge side obstacle is lower than the outdoor unit).

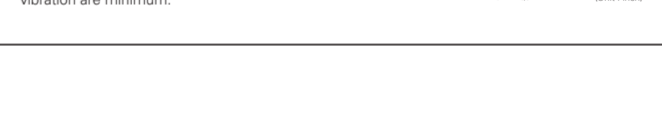

#### Outdoor unit

- 1 Remove the tubing cover from the unit by loosening the screw.

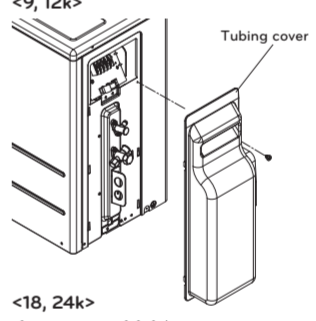

#### <9, 12k>

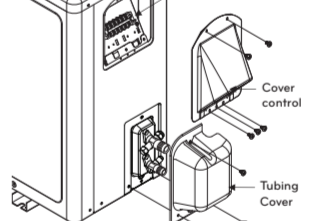

#### <18, 24k>

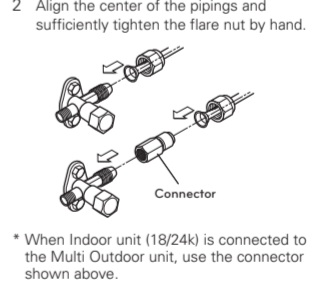

#### NOTE

- When Indoor unit (18/24k) is connected to the Multi Outdoor unit, use the connector shown above.

- Select a place where the warm air and noise from the air conditioner do not disturb neighbors.
- Sunroof is recommended for installations that are exposed to direct sunlight and for installations in cold climates with heavy snow which can accumulate on top of outdoor unit.

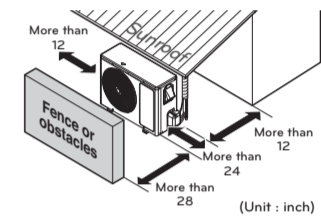

#### NOTE

- The feature can be changed according to type of model.

### Outdoor Unit Service Access and Allowable Clearances

- 1 Where there are obstacles on both suction and discharge sides (discharge side obstacle is lower than the outdoor unit).

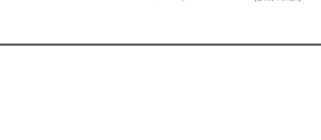
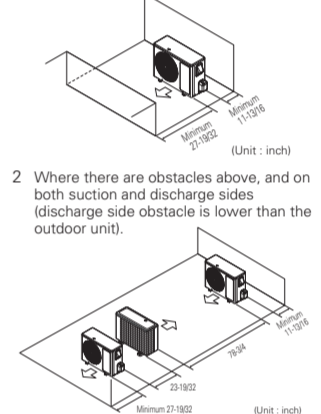

\* All power wiring/communication cables must comply with applicable local and national codes.  
 \* Field wiring shall be done such that the current-carrying conductors become taut before the earthing conductor if the cord slips out of the cord anchorage.

### Outdoor unit

- Remove the front panel (Right) or cover control from the unit by loosening the screw. Connect the wires to the terminals on the control board individually.
- Secure the cable onto the control board with the cord clamp.
- Refix the front panel(Right) to the original position with the screw.
- Use a recognized circuit breaker between the power source and the unit. A disconnecting device to adequately disconnect all supply lines must be fitted.

Circuit Breaker (A)	Capacity(Btu/h)
9, 12k	18, 24k
15	25

### <9, 12k>

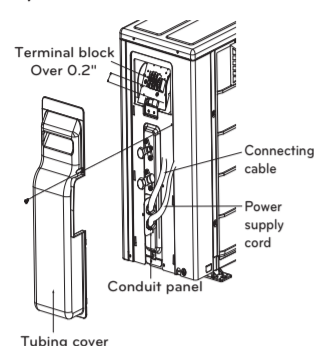

### <18, 24k>

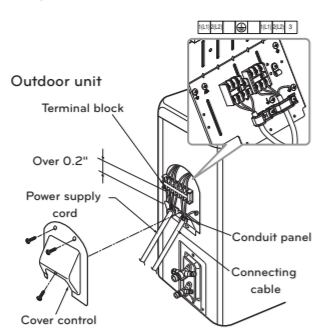

#### CAUTION

- When using the separate wire as the power cord, please fix the separate wire into the control box panel by using tie wrap as the fixture. 'A' & 'B' are minimum recommended wire size.
- Provide the circuit breaker between power source and the unit as shown by.

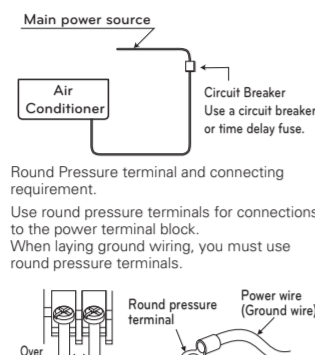

\* The feature can be changed according to type of model.

#### CAUTION

- According to the confirmation of the above conditions, prepare the wiring as follows.
- Never fail to have an individual power circuit specifically for the air conditioner. As for the method of wiring, be guided by the circuit diagram posted on the inside of control cover.
  - The screw which fasten the wiring in the casing of electrical fittings are liable to come loose from vibrations to which the unit is subjected during the course of transportation. Check them and make sure that they are all tightly fastened. (If they are loose, it could cause burn-out of the wires.)
  - Specification of power source.
  - Confirm that electrical capacity is sufficient.
  - See that the starting voltage is maintained at more than 90 percent of the rated voltage marked on the name plate.
  - Confirm that the cable thickness is as specified in the power source specification. (Particularly note the relation between cable length and thickness.)
  - Always install an earth leakage circuit breaker in a wet or moist area.
  - The following would be caused by voltage drop.
    - Vibration of a magnetic switch, which will damage the contact point, fuse breaking, disturbance of the normal function of the overload.
    - The means for disconnection from a power supply shall be incorporated in the fixed wiring and have an air gap contact separation of at least 0.12 in. in each active/neutral conductor.
  - Open the terminal cover block before connecting the indoor side wire.

### Finishing the indoor unit installation

- Mount the tubing holder in the original position.
- Ensure that the hooks are properly seated on the installation plate by moving it left and right.
- Press the lower left and right sides of the unit against the installation plate until the hooks engage into their slots (clicking sound).
- Finish the assembly by screwing the unit to the installation plate by using two pieces of type "C" screws. And assemble a chassis cover.

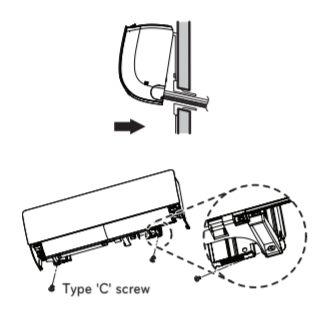

\* The feature can be changed according to type of model.

#### CAUTION

The indoor unit can be dropped from the wall, the indoor unit is not screwed correct position on the install plate. To avoid the gap between the indoor unit and wall, screw the indoor unit to the install plate correctly.

#### CAUTION

- Before finishing installation of the indoor unit, seal the hole of a wall except the pipe's ways to prevent condensate from inflow of outdoor air.

### Checking the Drainage

#### To check the drainage.

- Pour a glass of water on the evaporator.
- Ensure the water flows through the drain hose of the indoor unit without any leakage and goes out the drain exit.

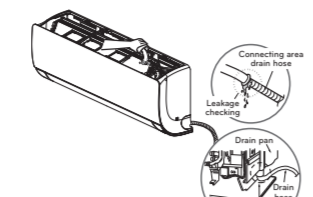

\* The feature can be changed according to type of model.



\* The feature can be changed according to type of model.

### Drain piping

- The drain hose should point downward for easy drain flow.

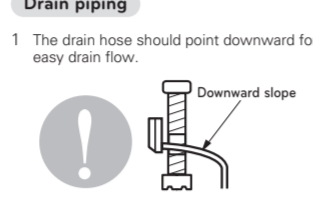

\* The feature can be changed according to type of model.

### Forming the Piping

Form the piping by wrapping the connecting portion of the indoor unit with insulation material and secure it with two kinds of vinyl tapes.

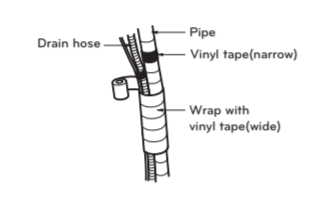

In cases where the outdoor unit is installed below the indoor unit perform the following.

- Seal a small opening around the pipings with gum type sealant.
- Secure the tapped piping along the exterior wall using saddle or equivalent.

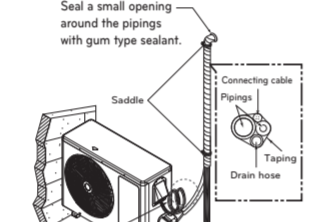

\* The feature can be changed according to type of model.

### Air Purging

- Pressure in the system rises.
- Operating current rises.
- Cooling/heating efficiency drops.
- Moisture in the refrigerant circuit may freeze and block capillary tubing.
- Water may lead to corrosion of parts in the refrigeration system.

Therefore, after evacuating the system, take a leak test for the piping and tubing between the indoor and outdoor unit.

### Air purging with vacuum pump

- Preparation
  - Check that each tube(both liquid and gas side tubes) between the indoor and outdoor units have been properly connected and all wiring for the test run has been completed. Remove the service valve caps from both the gas and the liquid side on the outdoor unit. Note that both the liquid and the gas side service valves on the outdoor unit are kept closed at this stage.

### Piping Length and Elevation

#### Single Split Model

Capacity (Btu/h)	Pipe Size		Standard Length (ft)	Max. Length (ft)	Max. Elevation (ft)	Additional Refrigerant (oz/ft)
	GAS	LIQUID				
9k / 12k	Ø 9.52 / 3/8	Ø 6.35 / 1/4	24.6	82	49.2	0.22
18k	Ø 15.88 / 5/8	Ø 9.52 / 3/8	24.6	114.8	49.2	0.38
24k	Ø 15.88 / 5/8	Ø 9.52 / 3/8	24.6	114.8	49.2	0.38

\* During the installation and binding of Multi model, refer to Multi outdoor unit installation manual.

#### Multi Model

Capacity (Btu/h)	Pipe Size		Standard Length (ft)	Max. Length (ft)	Max. Elevation (ft)	Additional Refrigerant (oz/ft)
	GAS	LIQUID				
7k / 9k / 12k / 15k	Ø 9.52	3/8	Ø 6.35	1/4		
18k / 24k	Ø 12.7	1/2	Ø 6.35	1/4		

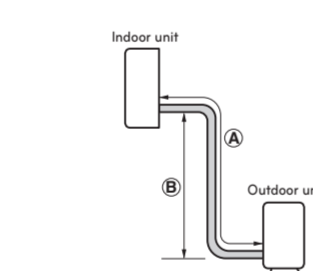

#### CAUTION

- Capacity is based on standard length and maximum allowable length is on the basis of reliability.
- Additional refrigerant must be charged after 41 ft (9k, 12k Model) / 24.6 ft (18k, 24k Model)

\* Refer to Multi outdoor unit installation manual.

### Operation ranges

The table below indicates the temperature ranges the air conditioner can be operated within. \*With wind baffle installed, the minimum temperature will be 0 °F D.B. in cooling.

Mode	Indoor temperature	Outdoor temperature
Cooling	64 ~ 90 °F	14 [0*] ~ 118 °F
Heating	61 ~ 86 °F	-4 ~ 75 °F

### Check test items

Test items	Check
1 Indoor unit is hooked to the installation plate properly.	
2 The gas and liquid service valves are fully opened.	
3 There is no refrigerant gas leakage.	
4 System is properly grounded.(No electrical leakage)	
5 The connection cable is clamped firmly.	
6 Indoor unit receives remote control commands and operates properly.	
7 Cooling/Heating operation is normal.	
8 There is no abnormal sound.	
9 There is no water leakage.	

#### NOTE

- Once the function is set up, heating and automatic operation cannot be used.
- Once the function is disable it will return to its normal state
- Code cannot be entered when it is in operation mode. It must be OFF state to enter code.
- Even if able to enter code in ON state, it won't function if the code is not entered in OFF state.
- Considering the communication time of the accessory built on the Air-conditioning, operate the accessory approximately after 1 min.
- Entire lock or mode lock cannot be set if heating and automatic operation is set through central controller

### How to enter the installer mode

Press Reset Button and 'A' Button (A)

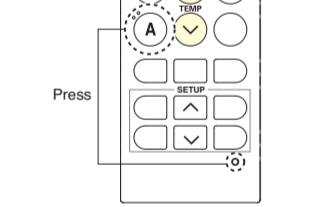

### How to set the code

Set the code you want by pressing TEMP button (TEMP) and press (CODE)

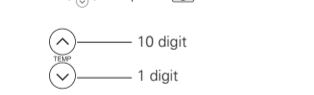

### Installation guide at the seaside

#### CAUTION

- Air conditioners should not be installed in areas where corrosive gases, such as acid or alkali gas, are produced.
- Do not install the product where it could be exposed to sea wind (salty wind) directly. It can result corrosion on the product. Corrosion, particularly on the condenser and evaporator fins, could cause product malfunction or inefficient performance.
- If outdoor unit is installed close to the sea-side, it should avoid direct exposure to the sea wind. Otherwise it needs additional anticorrosion treatment on the heat exchanger.

In case of installing the outdoor unit on the sea side, setup a windbreak to prevent sea wind.

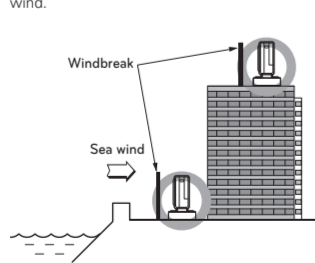

- It should be strong enough like concrete to prevent the sea wind from the sea.  
 - The height and width should be more than 150% of the outdoor unit.  
 - Keep more than 2.3 ft of space between outdoor unit and the windbreak for easy air flow.

Select a well-drained place.

#### NOTE

- If you can't meet above guide line in the seaside installation, please contact LG Electronics for the additional anticorrosion treatment.
- Periodic ( more than once/year ) cleaning of the dust or salt particles stuck on the heat exchanger by using water
- \* Do not use seawater when you clean up the heat exchanger.

### Auxiliary heater relay kit

Auxiliary heater relay kit is not available on single zone wall mounted models.

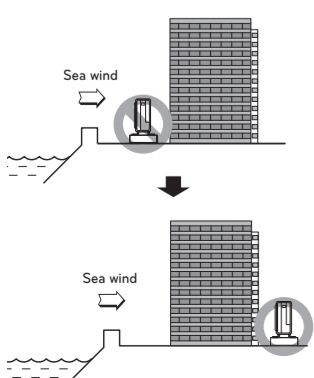

### Leak test

- Connect the manifold valve with pressure gauge(s) and dry nitrogen gas cylinder to this service port with charge hoses.

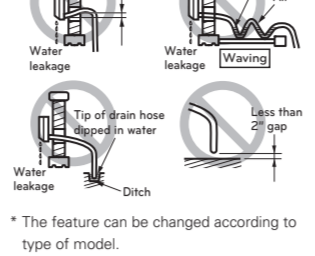

\* The feature can be changed according to type of model.

### Installing drain piping of the outdoor unit

Depending on installation site, it may be required to install drain plug for drainage (Supplied with the unit). In cold areas, do not use a drain hose with the outdoor unit. Otherwise, drain water may freeze, impairing the heating performance.

- See the figure below for installation of the drain plug.
  - A Drain nipple
  - B Drain cap
  - C Drain washer

2 Connect a field supplied vinyl hose to the drain nipple (A). If the hose is too long and hangs down, fix it carefully to prevent kinks.

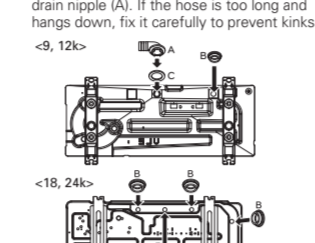

\* The feature can be changed according to type of model.

### Finishing the Job

- With a service valve wrench, turn the valve of liquid side counter-clockwise to fully open the valve.
- Turn the valve of gas side counter-clockwise to fully open the valve.
- Loosen the charge hose connected to the gas side service port slightly to release the pressure, then remove the hose.
- Replace the flare nut and its bonnet on the gas side service port and fasten the flare nut securely with an adjustable wrench. This process is very important to prevent leakage from the system.
- Replace the valve caps at both gas and liquid side service valves and fasten them tight. This completes air purging with a vacuum pump.

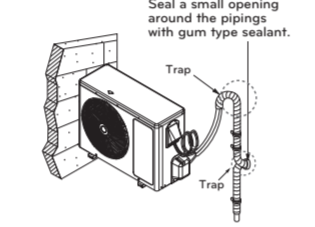

### Evacuation

- Connect the charge hose end described in the preceding steps to the vacuum pump to evacuate the tubing and indoor unit. Confirm the "Lo" knob of the pressure Gauge is open. Then, run the vacuum pump. The operation time for evacuation varies with tubing length and capacity of the pump. The following table shows the time required for evacuation.

Required time for evacuation when 30 galh vacuum pump is used
If tubing length is less than 33 ft
If tubing length is longer than 33 ft
10 min. or more
15 min. or more

\* The feature can be changed according to type of model.

### Manual the decor, air filter Assembly & Disassembly

#### Disassemble the decor

- Turn off the power and unplug the power cord.
- Pull the decor at the bottom of the indoor unit.

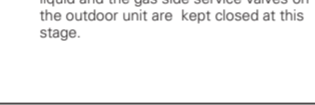

#### Disassemble the air filter

- Turn off the power and unplug the power cord.
- Hold the knob of the air filter. Lift it up slightly.



#### Assemble the decor

- Turn off the power and unplug the power cord.
- Insert 3 or 4 hooks of the decor into gap of the indoor unit certainly.

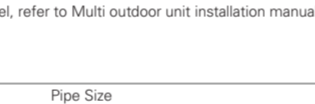

#### Assemble the air filter

- Turn off the power and unplug the power cord.
- Insert the hooks of the air filter into the front grille.



#### CAUTION

The air filter can be broken when it is banded.



#### NOTE

If the air filter is not assembled correctly, Dust and other substance come into the indoor unit. If look at the indoor unit from higher than it, can assemble the air filter easily.

#### CAUTION

If the air filter is not assembled correctly, Dust and other substance come into the indoor unit. If look at the indoor unit from higher than it, can assemble the air filter easily.

#### NOTE

If the air filter is not assembled correctly, Dust and other substance come into the indoor unit. If look at the indoor unit from higher than it, can assemble the air filter easily.

#### CAUTION

If the air filter is not assembled correctly, Dust and other substance come into the indoor unit. If look at the indoor unit from higher than it, can assemble the air filter easily.

#### NOTE

If the air filter is not assembled correctly, Dust and other substance come into the indoor unit. If look at the indoor unit from higher than it, can assemble the air filter easily.

#### CAUTION

If the air filter is not assembled correctly, Dust and other substance come into the indoor unit. If look at the indoor unit from higher than it, can assemble the air filter easily.

#### NOTE

If the air filter is not assembled correctly, Dust and other substance come into the indoor unit. If look at the indoor unit from higher than it, can assemble the air filter easily.

#### CAUTION

If the air filter is not assembled correctly, Dust and other substance come into the indoor unit. If look at the indoor unit from higher than it, can assemble the air filter easily.

#### NOTE

If the air filter is not assembled correctly, Dust and other substance come into the indoor unit. If look at the indoor unit from higher than it, can assemble the air filter easily.

#### CAUTION

If the air filter is not assembled correctly, Dust and other substance come into the indoor unit. If look at the indoor unit from higher than it, can assemble the air filter easily.

#### NOTE

If the air filter is not assembled correctly, Dust and other substance come into the indoor unit. If look at the indoor unit from higher than it, can assemble the air filter easily.

#### CAUTION

If the air filter is not assembled correctly, Dust and other substance come into the indoor unit. If look at the indoor unit from higher than it, can assemble the air filter easily.

#### NOTE

If the air filter is not assembled correctly, Dust and other substance come into the indoor unit. If look at the indoor unit from higher than it, can assemble the air filter easily.

### Leak test

- Connect the manifold valve with pressure gauge(s) and dry nitrogen gas cylinder to this service port with charge hoses.

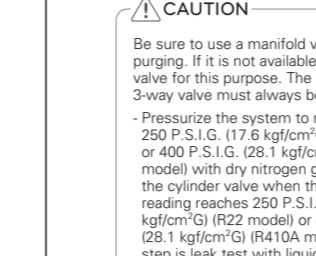

\* The feature can be changed according to type of model.

### Installing drain piping of the outdoor unit

Depending on installation site, it may be required to install drain plug for drainage (Supplied with the unit). In cold areas, do not use a drain hose with the outdoor unit. Otherwise, drain water may freeze, impairing the heating performance.

- See the figure below for installation of the drain plug.
  - A Drain nipple
  - B Drain cap
  - C Drain washer

2 Connect a field supplied vinyl hose to the drain nipple (A). If the hose is too long and hangs down, fix it carefully to prevent kinks.

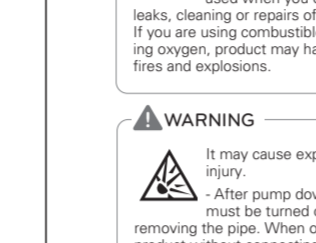

\* The feature can be changed according to type of model.

### Finishing the Job

- With a service valve wrench, turn the valve of liquid side counter-clockwise to fully open the valve.
- Turn the valve of gas side counter-clockwise to fully open the valve.
- Loosen the charge hose connected to the gas side service port slightly to release the pressure, then remove the hose.
- Replace the flare nut and its bonnet on the gas side service port and fasten the flare nut securely with an adjustable wrench. This process is very important to prevent leakage from the system.
- Replace the valve caps at both gas and liquid side service valves and fasten them tight. This completes air purging with a vacuum pump.

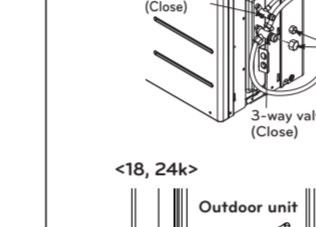

### Evacuation

- Connect the charge hose end described in the preceding steps to the vacuum pump to evacuate the tubing and indoor unit. Confirm the "Lo" knob of the pressure Gauge is open. Then, run the vacuum pump. The operation time for evacuation varies with tubing length and capacity of the pump. The following table shows the time required for evacuation.

Required time for evacuation when 30 galh vacuum pump is used
If tubing length is less than 33 ft
If tubing length is longer than 33 ft
10 min. or more
15 min. or more

\* The feature can be changed according to type of model.

### Manual the decor, air filter Assembly & Disassembly

#### Disassemble the decor

- Turn off the power and unplug the power cord.
- Pull the decor at the bottom of the indoor unit.



#### Disassemble the air filter

- Turn off the power and unplug the power cord.
- Hold the knob of the air filter. Lift it up slightly.

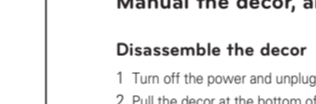

#### Assemble the decor

- Turn off the power and unplug the power cord.
- Insert 3 or 4 hooks of the decor into gap of the indoor unit certainly.

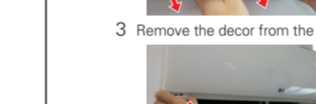

#### Assemble the air filter

- Turn off the power and unplug the power cord.
- Insert the hooks of the air filter into the front grille.



#### CAUTION

The air filter can be broken when it is banded.



#### NOTE

If the air filter is not assembled correctly, Dust and other substance come into the indoor unit. If look at the indoor unit from higher than it, can assemble the air filter easily.