

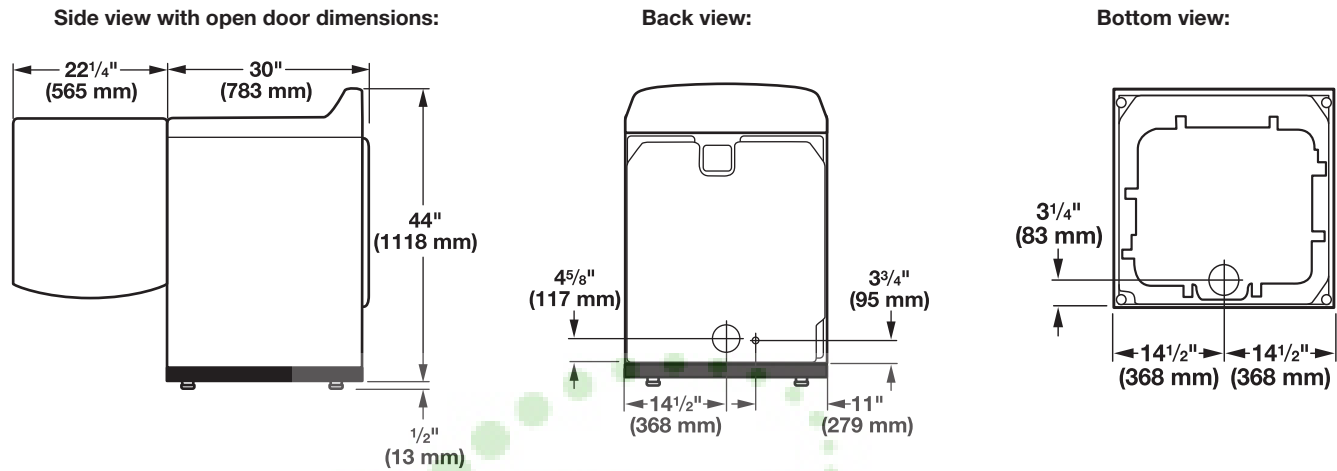

# Electric Dryer

## PRODUCT MODEL NUMBERS

MEDB750Y, MEDB850Y, MEDB950Y



**NOTE:** Most installations require a minimum of 5" (127 mm) clearance behind dryer for exhaust vent with elbow. See "Venting Requirements."

### Recommended Installation Spacing:

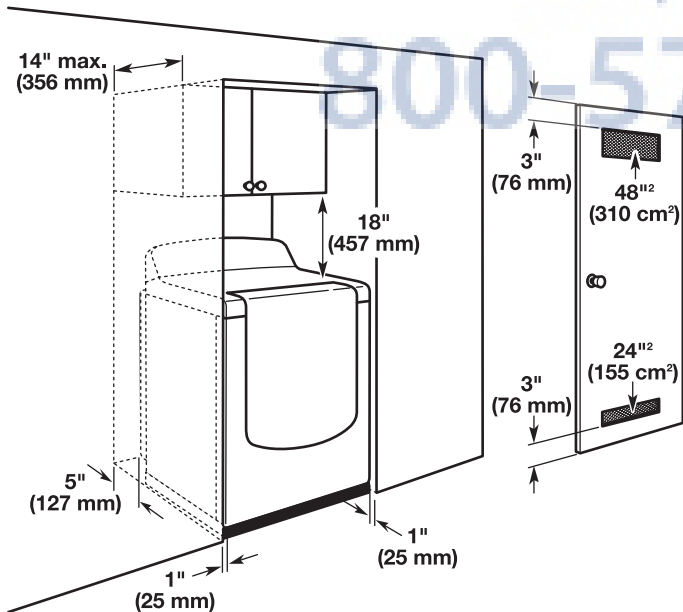

### Spacing for recessed area or closet installation

All dimensions show recommended spacing allowed, with tested spacing of 0" (0 mm) clearance on sides and rear.

- Additional spacing should be considered for ease of installation and servicing.
- Additional clearances might be required for wall, door, and floor moldings.
- Additional spacing should be considered on all sides of the dryer to reduce noise transfer.
- For closet installation, with a door, minimum ventilation openings in the top and bottom of the door are required. Louvered doors with equivalent ventilation openings are acceptable.
- Companion appliance spacing should also be considered.

## ELECTRICAL REQUIREMENTS

To supply the required 3 or 4 wire, single phase, 120/240 volt, 60 Hz., AC only electrical supply (or 3 or 4 wire, 120/208 volt electrical supply, if specified on the serial/rating plate) on a separate 30-amp circuit, fused on both sides of the line. A time-delay fuse or circuit breaker is recommended. Connect to an individual branch circuit.

## VENTING REQUIREMENTS

Exhaust venting: Exhaust your dryer to the outside. 4" (102 mm) diameter vent is required. Rigid or flexible metal exhaust vent must be used. Do not use plastic or metal foil vet. Exhaust hood must be at least 12" (305 mm) from the ground or any object that may be in the path of the exhaust.

### Exhaust hoods:

#### Recommended Styles:

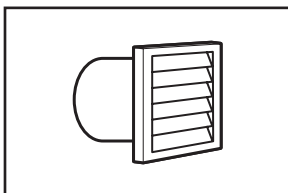

Louvered Hood

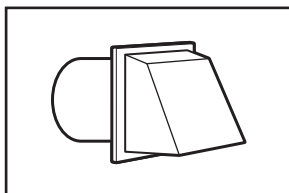

Box Hood

#### Acceptable Style:

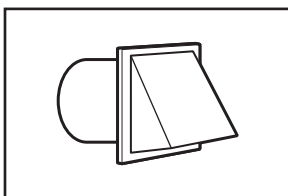

Angled Hood

The Vent System Chart provides venting requirements that will help achieve best drying performance.

### Maytag Vent System Chart

Number of 90° elbows	Type of vent	Box/louvered hoods	Angled hoods
0	Rigid metal	100 ft. (30.5 m)	94 ft. (28.7 m)
1	Rigid metal	90 ft. (27.4 m)	84 ft. (25.6 m)
2	Rigid metal	80 ft. (24.4 m)	74 ft. (22.6 m)
3	Rigid metal	71 ft. (21.6 m)	65 ft. (19.8 m)
4	Rigid metal	63 ft. (19.2 m)	57 ft. (17.4 m)

**NOTE:** Bottom exhaust installations have a 90° turn inside the dryer. To determine maximum exhaust length, add one 90° turn to the chart.

### Determine vent path:

- Select route that will provide straightest and most direct path outdoors.
- Plan installation to use fewest number of elbows and turns.
- When using elbows or making turns, allow as much room as possible.
- Bend vent gradually to avoid kinking.
- Use as few 90° turns as possible.

### Determine vent length and elbows needed for best drying performance:

- Use following Vent System Chart to determine type of vent material and hood combinations acceptable to use.

**NOTE:** Do not use vent runs longer than those specified in Vent System Chart. Exhaust systems longer than those specified will:

- Shorten life of dryer.
- Reduce performance, resulting in longer drying times and increased energy usage.