

# BERTAZZONI MASTER SERIES

30" 4 INDUCTION ZONES, ELECTRIC CONVECTION OVEN

MAS30 4 INM XE

## HIGHLIGHTS

- The 4-zones induction worktop with variable heat and power boost function accommodates full-size cookware for super-fast yet precise cooking.
- The extra-wide oven with heat-assisted convection fan and full-width broiler provides balanced air flow and even heat distribution.
- The soft-motion oven door is specially designed and carefully balanced for easy opening and smooth closing with one hand.



## FEATURES

<b>Induction Zones</b>	4
<b>Worktop</b>	induction
<b>Worktop Controls</b>	knobs
<b>Residual Heat Indicator</b>	yes
<b>Knobs</b>	soft touch
<b>Backguard</b>	standard 4 inches
<b>Front Left</b>	7"-1850 W (Booster 3000 W)
<b>Back Left</b>	7"-1850 W (Booster 3000 W)
<b>Front Right</b>	5" <sup>3</sup> / <sub>4</sub> -1400 W (Booster 2200 W)
<b>Back Right</b>	8" <sup>1</sup> / <sub>2</sub> -2300 W (Booster 3700 W)
<b>Simmer rate</b>	750 Btu/h
<b>Main oven</b>	electric convection with electric broiler
<b>Main oven functions</b>	bake, traditional bake, upper bake, broil, large broil, convection broil, convection, defrost/dehydrate
<b>Main oven volume</b>	3.6 ft <sup>3</sup>
<b>Inner oven door</b>	full width triple glass
<b>Oven equipment</b>	1 baking tray, 2 heavy gauge wire shelves, 1 grill trivet for tray
<b>Legs</b>	height adjustable stainless steel legs

## TECHNICAL SPECIFICATIONS

<b>Voltage, frequency</b>	120/208 V - 120/240 V, 60Hz
<b>Max Amp Usage, power rating</b>	44 A - 9800 W, 45.5 A - 10500 W
<b>Rating*</b>	Specified Rating of Power Supply Cord Kit and Circuit Protection 208/240 Volts 120/208 Volts Amps: 40 A
<b>Certification</b>	cETLus
<b>Warranty</b>	2 years parts and labor

## ACCESSORIES

Toe kick panel (TKS 30 X), flat island trim (IRF 30 X), side trim (ST 36 X)  
Telescopic glide shelves (TGC)

## MATCHING VENTILATION SOLUTIONS

Bertazzoni offers a variety of matching ventilation solutions for this range. Please check our website under the ventilation tab for a complete overview of all choices



TO COOK BEAUTIFULLY  
WWW.BERTAZZONI.COM

# INSTALLATION INSTRUCTIONS

## MAS30 4 INM XE

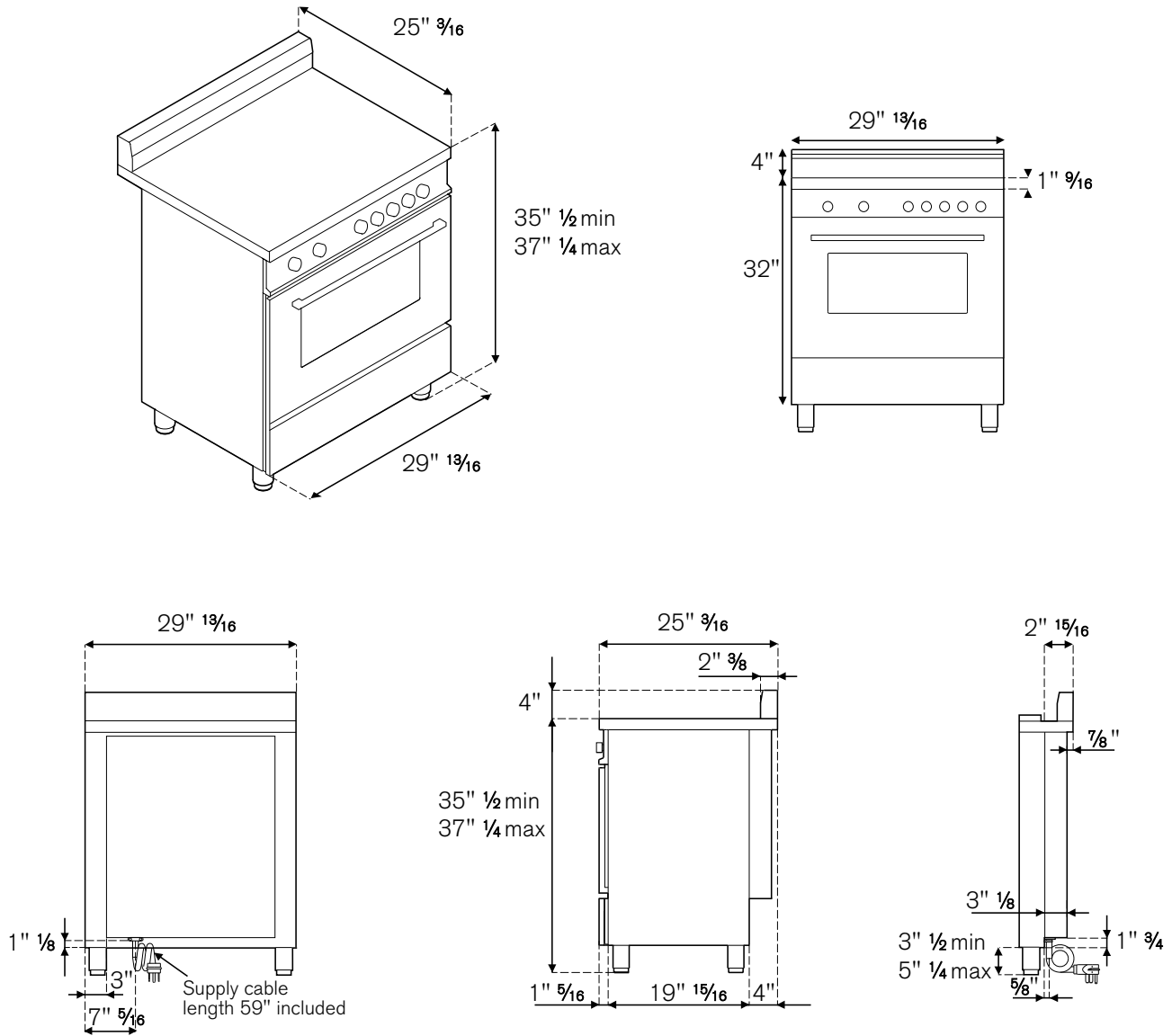

\*The National Electric Code calculation for Electric Load is less than the Total Connected Electrical Load listed on the model rating plate.

Bertazzoni recommends to operate the appliance after it has been installed in a cabinet. The kitchen cabinets shall be made of materials capable of withstanding temperatures at least 117°F (65°C) above room temperature in order to avoid possible damage to the cabinets during oven usage. For further installation instructions refer to the installation manual.

**Disclaimer:** while every effort has been made to insure the accuracy of the information contained in this brochure, Fratelli Bertazzoni reserves the right to change any part of the information at any time without notice.

Fratelli Bertazzoni, Bertazzoni and the winged wheel brand icon are registered trademarks of Bertazzoni Spa.