

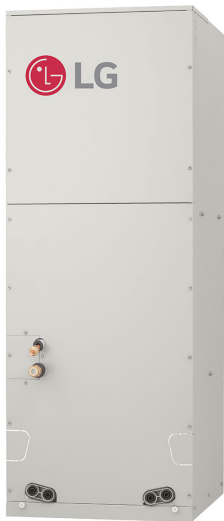

MULTI F

MULTI F MAX

INDOOR UNIT ENGINEERING MANUAL



Vertical-Horizontal
Air Handling Units



Art Cool™ Mirror
Wall-Mounted



Art Cool™ Gallery
Wall-Mounted



Four-Way Ceiling Cassette



Ceiling-Concealed Duct

Indoor Units for Multi-Zone Heat Pump Systems
7,000 to 36,000 Btu/h





PROPRIETARY DATA NOTICE

This document, as well as all reports, illustrations, data, information, and other materials are the property of LG Electronics U.S.A., Inc., and are disclosed by LG Electronics U.S.A., Inc., only in confidence.
This document is for design purposes only.

EM_MultiF_IDU_3_18

For continual product development, LG reserves the right to change specifications without notice.
©LG Electronics Inc.

TABLE OF SYMBOLS

 DANGER	<i>This symbol indicates an imminently hazardous situation which, if not avoided, will result in death or serious injury.</i>
 WARNING	<i>This symbol indicates a potentially hazardous situation which, if not avoided, could result in death or serious injury.</i>
 CAUTION	<i>This symbol indicates a potentially hazardous situation which, if not avoided, may result in minor or moderate injury.</i>
Note:	<i>This symbol indicates situations that may result in equipment or property damage accidents only.</i>
	<i>This symbol indicates an action that should not be performed.</i>

This document, as well as all reports, illustrations, data, information, and other materials are the property of LG Electronics U.S.A., Inc.

MULTI F MULTI F MAX

TABLE OF CONTENTS

Convergence of Technology, Innovation, Flexibility, & Style	4
Unit Nomenclature	5
Functions, Controls and Options Overview	6
Art Cool Mirror Indoor Units	10
Mechanical Specifications and Features.....	10
General Data / Specifications.....	11
Dimensions.....	12
Cooling Capacity Table.....	14
Heating Capacity Table.....	16
Acoustic Data.....	17
Air Velocity and Temperature Distribution.....	18
Refrigerant Flow Diagram.....	19
Wiring Diagram.....	20
Factory Supplied Parts and Materials.....	21
Installation and Best Layout Practices.....	22
Art Cool Gallery Indoor Units	29
Mechanical Specifications and Features.....	29
General Data / Specifications.....	30
Dimensions.....	31
Cooling Capacity Table.....	32
Heating Capacity Table.....	33
Acoustic Data.....	34
Air Velocity and Temperature Distribution.....	35
Refrigerant Flow Diagram.....	36
Wiring Diagram.....	37
Factory Supplied Parts and Materials.....	38
Installation and Best Layout Practices.....	39
Standard Wall-Mounted Indoor Units	49
Mechanical Specifications and Features.....	49
General Data / Specifications.....	50
Dimensions.....	51
Cooling Capacity Table.....	53
Heating Capacity Table.....	56
Acoustic Data.....	58
Air Velocity and Temperature Distribution.....	60
Refrigerant Flow Diagram.....	62
Wiring Diagram.....	63
Factory Supplied Parts and Materials.....	65
Installation and Best Layout Practices.....	66
Duct (Low Static) Indoor Units	73
Mechanical Specifications and Features.....	73
General Data / Specifications.....	74
Dimensions.....	75
Cooling Capacity Table.....	76
Heating Capacity Table.....	78
External Static Pressure.....	79
Acoustic Data.....	80
Refrigerant Flow Diagrams.....	81
Wiring Diagram.....	83
Factory Supplied Parts and Materials.....	84
Installation and Best Layout Practices.....	85
Duct (High Static) Indoor Units	95
Mechanical Specifications and Features.....	95
General Data / Specifications.....	96
Dimensions.....	97
Cooling Capacity Table.....	98
Heating Capacity Table.....	99
External Static Pressure / Acoustic Data.....	100
Refrigerant Flow Diagrams.....	101
Wiring Diagrams.....	102

Factory Supplied Parts and Materials / Installation.....	103
Installation and Best Layout Practices.....	104
Four-Way Ceiling Cassette Indoor Units	113
Mechanical Specifications and Features.....	113
General Data / Specifications.....	114
Dimensions.....	115
Cooling Capacity Table.....	117
Heating Capacity Table.....	120
Acoustic Data.....	121
Air Velocity and Temperature Distribution.....	123
Refrigerant Flow Diagram.....	125
Wiring Diagram.....	126
Factory Supplied Parts and Materials.....	127
Installation and Best Layout Practices.....	128
Two-Way VAHU Indoor Units	137
Mechanical Specifications and Features.....	137
General Data / Specifications.....	138
Dimensions.....	139
Cooling Capacity Table.....	140
Heating Capacity Table.....	141
External Static Pressure.....	142
Acoustic Data.....	143
Refrigerant Flow Diagram.....	144
Wiring Diagram.....	145
Factory Supplied Parts and Materials.....	147
Installation and Best Layout Practices.....	148
Four-Way VAHU Indoor Units	157
Mechanical Specifications and Features.....	157
General Data / Specifications.....	158
Dimensions.....	159
Cooling Capacity Table.....	160
Heating Capacity Table.....	162
External Static Pressure and Airflow Ranges.....	164
Acoustic Data.....	167
Refrigerant Flow Diagram.....	170
Wiring Diagram.....	171
Factory Supplied Parts and Materials.....	173
Installation and Best Layout Practices.....	174
Application Guidelines	183
Equipment Selection Procedure.....	184
Placement Considerations.....	191
Refrigerant Piping Design	198
Design Guideline Summary.....	198
Creating a Balanced System / Manual Layout Procedure.....	200
Condensate Drain Piping.....	201
Electrical Connections	204
General Information.....	204
Power Wiring (208-230V) and Comm Cable Details.....	207
Remote Controller Connections.....	212
Indoor Unit Group Control.....	213
Acronyms	214

CONVERGENCE OF TECHNOLOGY, INNOVATION, FLEXIBILITY, & STYLE



About LG Electronics, Inc.

LG Electronics is a global leader and technology innovator in consumer electronics, mobile communications, and home appliances. LG Electronics comprises five business units—Home Entertainment, Mobile Communications, Air Conditioning, Business Solutions, and Home Appliance. LG is one of the world's leading producers of flat panel televisions, audio and video products, mobile handsets, air conditioners, and washing machines. LG's commercial air conditioning business unit was established in 1968 and has built its lineup of residential and commercial products to include VRF, Multi F, duct-free split systems, packaged terminal air conditioners (PTACs), and room air conditioners. In 2011, the air conditioning and energy solutions business unit grew to include LED lighting and solar products. For more information, visit www.lg.com.

Multi-Zone Systems

LG HVAC systems offer a range of solutions that are cost efficient, quiet and attractive. Multi-zone systems are "split" into indoor and outdoor units, and provide a smart alternative to both central HVAC and window-mounted air conditioners. These inverter heat pump systems are available in a variety of configurations to suit different cooling and heating situations. Installation by a trained HVAC contractor is safe and easy – little to no duct work or sheet metal is required.

Multi F Systems

LG's inverter heat pumps can support two, three, or four indoor units that are typically installed in separate rooms. Each indoor unit

Benefits of Multi F Systems

- Individual zone control
- Long refrigerant piping lengths
- High refrigerant piping elevation differences
- Maximum flexibility
- Operating ranges of 14°F to 118°F (DB) in cooling and -4°F to 75°F (DB) in heating if connected to standard Multi F Outdoor Units or -13°F to 75°F (DB) in heating if connected to Multi F with LG RED° Outdoor Units.
- Quiet and comfortable environment
- Reduced ductwork



includes its own remote control, allowing the customer to set the temperature individually. Indoor units are available in several different configurations: Art Cool™ Mirror wall-mounted, Art Cool Gallery wall-mounted, standard wall-mounted, four-way ceiling cassettes, ceiling-concealed duct (high and low static), and vertical-horizontal air handling models. Multi F MAX systems can operate up to eight indoor units through two-, three-, or four-port branch distribution units.

Adaptable and Flexible

Multi F outdoor units can be adapted to a wide range of building applications and sizes such as schools, hotels, hospitals, offices, and residences. The system components are lightweight and compact so they can be placed in buildings without expensive cranes, they easily fit into most service elevators, and they can be set in place with minimal structural reinforcements requirements.

Multi F technology allows you to pipe farther by reaching areas of the building that would require the installation of a second system when using traditional direct-expansion cooling and heating equipment. Multi F provides the designer with uncompromised pipe system engineering flexibility—long pipe runs and large elevation differences. Whether your building is a condominium, a hotel, a school, or an office complex, Multi F is best suited to reach the farthest corners and elevations.

Smaller Chases and Plenums

LG Multi F systems use refrigerant piping to move heat, resulting in smaller space requirements for piping as compared to chilled water or roof top systems. This helps reduce the overall construction and material cost of the building, and gives back leasable space. Flexible and logical placement of system components, reduced back-and-forth pipe lengths, and fewer joints lowers installation costs and minimizes potential leaking.

Quality Commitment

LG is committed to the success of duct-free projects. We provide technical support during installation and commissioning. LG offers a variety of classes designed for installers and servicers on Multi F installation. Classes are conducted at LG's training centers and in field locations at various times throughout the year and on special request.



MULTI F

Multi-Zone Systems — Indoor Units and Outdoor Units

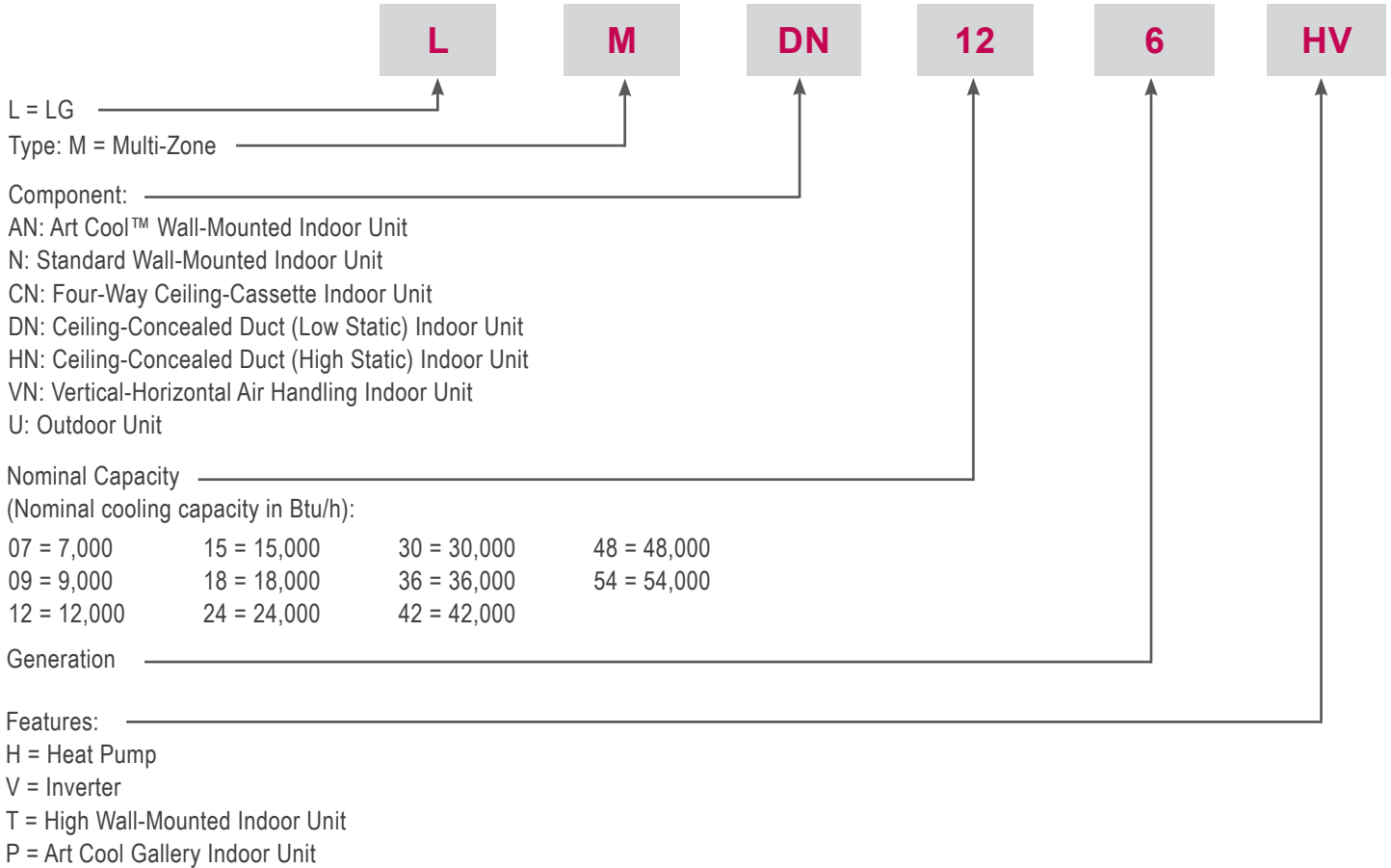

Introduction

Branch Distribution Units

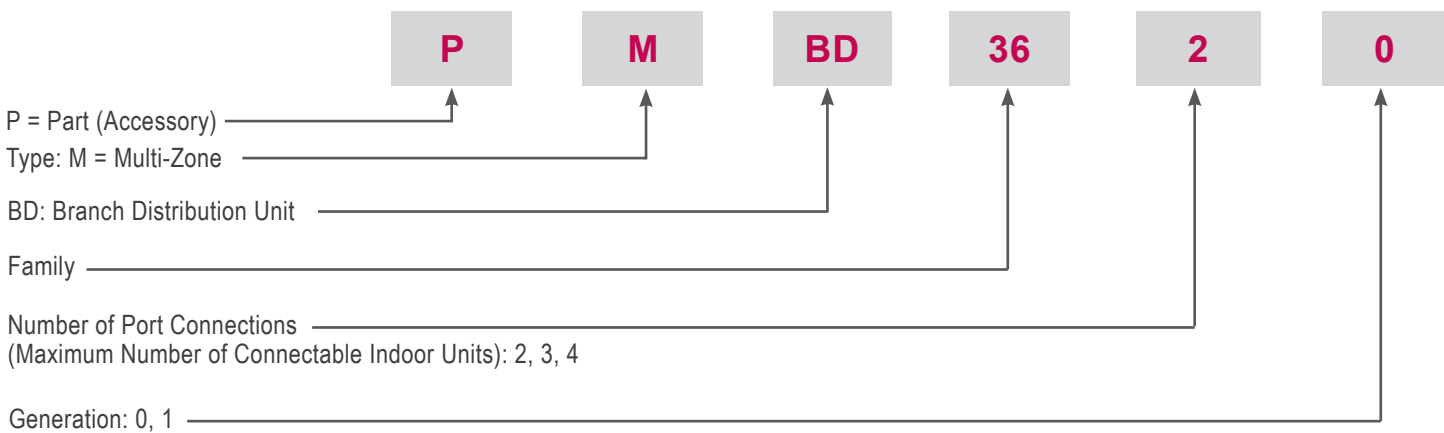

Note:

- Voltage for all equipment is 208-230V, 60 Hz, 1-phase.
- All indoor units are compatible with wired controllers.
- All outdoor units are LGAP control network compatible with PI-485 V-net Control Integration Board (PMNFP14A1, sold separately).
- Compatible single zone IDU nomenclature is listed in the Single Zone Wall-Mounted IDU Engineering Manual.



FUNCTIONS, CONTROLS AND OPTIONS OVERVIEW

MULTI F
MULTI F MAX

Table 1: Indoor Units—Functions, Controls and Options.

Indoor Unit Type		ART COOL™ Mirror Wall Mounted	ART COOL™ Gallery	Standard Wall Mounted	Ceiling Concealed (Low Static) Ducted	Ceiling Concealed (High Static) Ducted	Four-Way Ceiling Cassette	Vertical- Horizontal Air Handling Unit
Airflow	Air supply outlets	1	3	1	1	2	4	1
	Airflow direction (left/right)	Auto	Auto	Auto				
	Airflow direction (up/down)	Auto	Auto	Auto			Auto	
	Auto swing (left/right)	√	√	√				
	Auto swing (up/down)	√	√	√			√	
	Airflow steps (fan/cool/heat)	6 / 6 / 6	5 / 5 / 4	6 / 6 / 6	3 / 3 / 3	3 / 3 / 3	4 / 5 / 4	3 / 3 / 3
	Comfort Air (random fan speed)	√	√	√			√	
	Jet-cool/Jet Heat (power wind)	√	√	√			√	
	Swirl wind						√	
Filter	Washable anti-fungal ¹	√	√	√	√	√	√	
	Plasma ²						o ³	
	3M Micro Dust Filter ²	√		√				
	Ventilation						√ ⁴	
Operation	Drain pump				√	√	√	
	E.S.P. control				√	√		√
	Electric heater							o
	High ceiling ⁵						√	
	Hot Start	√	√	√	√	√	√	√
	Self diagnostics	√	√	√	√	√	√	√
	Soft Dry (dehumidification)	√	√	√	√	√	√	√
	Auto operation	√	√	√	√	√	√	√
	Auto clean (coil dry)	√	√	√				
	Auto restart	√	√	√	√	√	√	
	Child lock	o	o	o	o	o	o	o
	Forced operation	√	√	√			√	
	Group control – Requires the use of one Group control Cable Kit (PZCWRCG3) for every additional indoor unit	o	o	o	o	o	o	o ⁵
	Sleep mode	√	√	√	√	√	√	√
	Timer (on/off)	√	√	√	√	√	√	√
	Weekly schedule	o	o	o	√	√	o	√
	Two thermistor control	o	o	o	o	o	o	o
Controllers	7-Day programmable controller	o	o	o	o	o	o	o
	Simple wired remote controller	o	o	o	√	√	o	√
	Wireless LCD remote control	√	√	√	o ⁶	o ⁶	√	o ⁶
	Dry contact	o	o	o	o	o	o	√ ⁷
	Dry contact (temperature setting)	o	o	o	o	o	o	o
	Central control (LGAP)	√	√	√	√	√	√	√
	Connector for Water Sensor	√	√	√				
Special Function	Wi-Fi ⁸	√		√				o

¹Primary washable filters.

²Secondary filter

³Branch location and static pressure requirements. Requires PTPKQ0 Plasma kit.

⁴Requires ventilation kit PTVK430 (Temperature, humidity, and volume limitations apply).

⁵Group control may affect available features

⁶Requires wired zone controller

⁷For use with 3rd party thermostat

⁸Embedded. Optional for LVNxxxHV4 4-way VAHU. Not available for 2-way LMVNxxxHV VAHU.

√ = Standard feature

o = Unit option



Table 2: Indoor Unit Accessories Overview.

Model No.	Description
<i>For Four-Way Ceiling-Cassette Indoor Units</i>	
PT-QCHW0	Ceiling Grille
PT-UQC	Ceiling Grille
PTVK430	Flange for All Capacities
PTDCQ	Decorative Cover
PTPKQ0	Plasma Filter
PRARH0	Aux Heat Relay Kit
<i>Wall-Mounted Indoor Units</i>	
PCRCUDT3	Wi-Fi Module (LSN/LMN models)
AG-9300-LG	Condensate Sensor
PRARS1	Aux Heat Relay Kit
<i>For Vertical-Horizontal Air Handling Units</i>	
PNDPJ0	Downflow Conversion Kit (18/24MBH)
PNDFK0	Downflow Conversion Kit (36MBH)
ANEH033B1	3 kW Electric Heater (18-36MBH)
ANEH053B1	5 kW Electric Heater (18-36MBH)
ANEH083B2	8 kW Electric Heater (18-36MBH)
ANEH103B2	10 kW Electric Heater (18-36MBH)
ANEH153B2	15 kW Electric Heater (36MBH)
ANEH203B2	20 kW Electric Heater (36MBH)
PRARH0	Aux Heat Relay Kit
PCRCUDT3	Wi-Fi Module
<i>For Ceiling-Concealed Duct (High Static) Indoor Units</i>	
ZFBXBG01A	High Efficiency Filter Box
ZFBXD201A	Dynamic V8 2VL Low Profile Air Cleaner
ZPLMV201A	Dynamic 2VL Air Cleaner Low Profile Return Air Plenum
ZFBXD402A	Dynamic V8 4VL Low Profile Air Cleaner
ZPLMV402A	Dynamic 4VL Air Cleaner Low Profile Return Air Plenum
ZFLT1301A	4-Pack Dynamic V8 VL Air Cleaner Replacement Filter Pads
ZFLT1302A	24-Pack Dynamic V8 VL Air Cleaner Replacement Filter Pads
ZGRLRA01A	Dynamic V8 Air Cleaner Louvered Return Air Grille (one per plenum)
ZGRLRA02A	Dynamic V8 Air Cleaner Egg Crate Return Air Grille (one per plenum)
PRARH0	Aux Heat Relay Kit
<i>Controls Accessories</i>	
PQWRHQ0FDB	Wireless Handheld Remote (Duct/VAHU)
PREMTA000A	Premium Controller
PREMTB10U	Programmable Controller
PQRCVCL0Q(W)	Simple Controller (Wall/Cassette)
PREMTBVC0	MultiSITE CRC1 Base Controller
PREMTBVC1	MultiSITE CRC1 Plus Controller
ZVRCZ****	MultiSITE CRC1 Wireless Accessories
PDRYCB100	Dry Contact (Simple)
PDRYCB300	Dry Contact (3rd party controller)
PDRYCB400	Dry Contact (Setback)
ZRTBS01	Remote Temp Sensor (Cassette/Duct/VAHU)
PZCWRCG3	Group Control Cable Kit
PZCWRC1	Controller Extension Cable

ART COOL™ MIRROR INDOOR UNIT DATA

“Mechanical Specifications” on page 10

“General Data / Specifications” on page 11

“Dimensions” on page 12

“Cooling Capacity Table” on page 14

“Heating Capacity Table” on page 16

“Acoustic Data” on page 17

“Air Velocity and Temperature Distribution” on page 18

“Refrigerant Flow Diagram” on page 19

“Wiring Diagram” on page 20

“Factory Supplied Parts and Materials” on page 21

“Installation and Best Layout Practices” on page 22

ART COOL MIRROR INDOOR UNITS

Mechanical Specifications and Features

MULTI F
MULTI F MAX

ART COOL Mirror Wall-Mounted Indoor Units

General

All LG indoor units are factory assembled, wired, piped, and provided with a control circuit board, fan, and motor. ART COOL Mirror Wall-Mounted indoor units have a sound rating no higher than 44 dB(A) as tested per KSA0701 ISO Standard 3745.

Coil

Indoor unit coils are comprised of a minimum of two rows of aluminum fins mechanically bonded to copper tubing. The coils are pressure tested at the factory. Each unit is provided with a factory installed condensate drain pan below the coil.

Refrigerant System

System is designed for use with R410A refrigerant. The refrigeration circuit is pressure-tested at the factory and shipped with a holding charge of helium gas. Refrigerant pipe connections are 45° flare. All refrigerant lines from the outdoor unit to the indoor units must be field insulated.

Electrical

Each indoor unit is designed to operate using 208–230/60/1 power with voltage variances of $\pm 10\%$.

Casing

Units are designed to mount on a vertical surface, and are shipped with a separate back plate that secures the unit to the wall, protruding no more than nine (9) inches. Unit is designed so that refrigerant piping can be installed in one (1) of four (4) different directions.

Finish

The Art Cool Mirror unit has a flat, architectural panel with a smoked charcoal mirror finish. Unit casing has a dark grey finish and is manufactured of heavy-duty acrylonitrile butadiene styrene (ABS) and high impact polystyrene (HIPS) plastic.

Fan Assembly and Control

The unit has a single, direct-drive, crossflow fan made of high strength ABS plastic. The fan motor is brushless digitally controlled (BLDC) with permanently lubricated and sealed ball bearings. The fan and motor assembly is mounted on vibration attenuating rubber grommets. Fan speed is controlled using a microprocessor-based direct digitally controlled algorithm that provides pre-programmed, field-selectable fixed or auto fan speeds in the Heating and Cooling modes. For Art Cool Mirror Wall-Mounted units, the indoor fan has Low, Med, High, Jet Cool and Auto settings for Cooling mode; and has Low, Med, High, Jet Heat and Auto settings for Heating mode. The Auto setting adjusts the fan speed based on the difference between the controller setpoint and space temperature. Also, the separate Chaos setting provides a simultaneous and random change in fan speed and flow direction at the discharge, simulating a natural outdoor breeze.

Features

- Inverter (Variable speed fan)
- Comfort Air
- 3M filter
- Jet cool/Jet heat
- Group Control
- Self-cleaning indoor coil
- Auto operation
- Auto restart operation
- Built-in wi-fi
- Dehumidifying function
- Self diagnosis function
- Wireless LCD remote control included

Figure 1: Multi F Art Cool Mirror Wall-Mounted Indoor Unit.



Air Filter

Return air inlet has a factory-supplied primary removable, washable filter. The unit is also equipped with a secondary 3M Micro Dust filter. Filters are accessed from the front of the unit without the use of tools.

Airflow Guide Vanes

A motorized guide vane is factory installed, and allows the ability to control the direction of airflow from side to side. A motorized louver provides an automatic change in airflow by directing the air up and down to provide uniform air distribution.

Microprocessor Control

The indoor unit is provided with an integrated control panel to communicate with the outdoor unit. All unit operation parameters are stored in non-volatile memory resident on the unit microprocessor. The microprocessor controls space temperature through using the value provided by the temperature sensor within the indoor unit. The microprocessor control will activate indoor unit operation when the indoor room temperature falls below or rises above a setpoint temperature, at which point, a signal is sent to the outdoor unit to begin the appropriate mode. The microprocessor will also provide self-diagnostics and auto restart functions. A field-supplied four-wire power/communications cable must be installed to connect the indoor unit(s) to the outdoor unit.

Controls

The indoor unit casing has a factory-standard, integral infrared sensor designed to communicate with the supplied LG wireless handheld remote controller. An optional LG supplied wired controller is available as an additional accessory. Communication between the indoor units and the outdoor unit is accomplished through 18 AWG, four-core, stranded and shielded power/communication cable. The indoor unit has built-in wi-fi and can be controlled with LG's SmartThinQ app on a smart device. A field-supplied wi-fi network and smart device are required. The SmartThinQ app is free and is available for Android and iOS smart devices.

Condensate

The unit is designed for gravity draining of condensate and includes a flexible drain hose capable of installation in one of two directions. Unit includes a connection that is compatible with the AquaGuard® AG-9300-LG condensate sensor.

Table 3: Multi F Art Cool Mirror Indoor Unit General Data.

Model Name	LAN090HSV5	LAN120HSV5	LAN180HSV5
Nominal Cooling Capacity (Btu/h) ¹	9,000	12,000	18,000
Nominal Heating Capacity (Btu/h) ¹	10,900	13,600	21,600
<i>Operating Range</i>			
Cooling (°F WB)	57-77		
Heating (°F DB)	59-81		
<i>Fan</i>			
Type	Cross Flow		
Motor Output (W) x Qty.	30 x 1		60.0 x 1
Motor/Drive	Brushless Digitally Controlled / Direct		
Airflow Rate CFM (H/M/L)	268 / 218 / 169	282 / 233 / 177	558 / 438 / 353
<i>Unit Data</i>			
Refrigerant Type ²	R410A		
Refrigerant Control	EEV		
Power Supply V, Ø, Hz ³	208-230, 1, 60		
Rated Amps (A)	0.4		
Sound Pressure Level ±3 dB(A) (H/M/L) ⁴	36 / 32 / 27	38 / 34 / 29	44 / 38 / 34
Dimensions (W x H x D, in.)	32-15/16 x 12-1/8 x 7-9/16		39-9/32 x 13-19/32 x 8-11/32
Net Unit Weight (lbs.)	20.5		29.8
Shipping Weight (lbs.)	25.6		36.4
Power Wiring / Communications Cable (No. x AWG) ⁵	4 x 18		
Heat Exchanger (Row x Column x Fin / inch) x Number	(2 x 23 x 22) x 1		(2 x 16 x 20) x 1
<i>Pipe Size</i>			
Liquid (in.)	1/4		
Vapor (in.)	3/8		1/2
<i>Connection Size</i>			
Liquid (in.)	1/4		3/8
Vapor (in.)	3/8		5/8
Drain O.D. / I.D. (in.)	27/32, 5/8		

¹Nominal capacity is rated 0 ft. above sea level with corresponding refrigerant piping length in accordance with standard length of each outdoor unit and a 0 ft. level difference between outdoor and indoor units. All capacities are net with a combination ratio between 95 – 105%.

Nominal cooling capacity rating obtained with air entering the indoor unit at 80°F dry bulb (DB) and 67°F wet bulb (WB) and outdoor ambient conditions of 95°F dry bulb (DB) and 75°F wet bulb (WB). Nominal heating capacity rating obtained with air entering the indoor unit at 70°F dry bulb (DB) and 60°F wet bulb (WB) and outdoor ambient conditions of 47°F dry bulb (DB) and 43°F wet bulb (WB).

²This unit comes with a dry helium charge.

³Acceptable operating voltage: 187V-253V.

⁴Sound pressure levels are tested in an anechoic chamber under ISO Standard 3745 and are the same in both cooling and heating mode. These values can increase due to ambient conditions during operation.

⁵All power wiring / communications cable to the IDUs be minimum 18 AWG, 4-conductor, stranded, shielded or unshielded (if shielded, must be grounded to chassis at ODU only) and must comply with applicable local and national codes.

ART COOL MIRROR INDOOR UNITS

Dimensions

MULTI F
MULTI F MAX

Figure 2: LAN090HSV5 and LAN120HSV5 Dimensions.

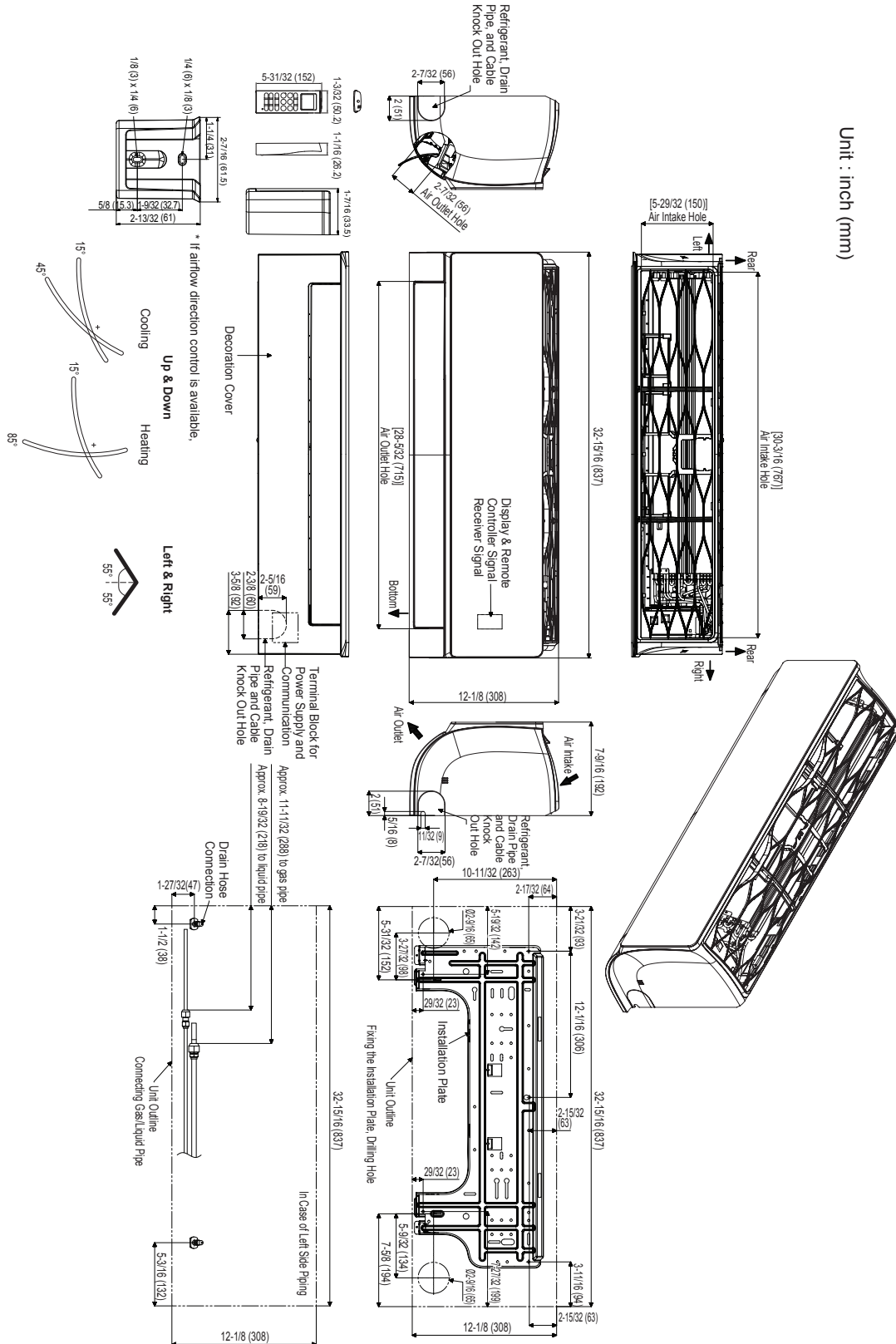

Multi F and Multi F MAX Indoor Unit Engineering Manual



Figure 3: LAN180HSV5 Dimensions.

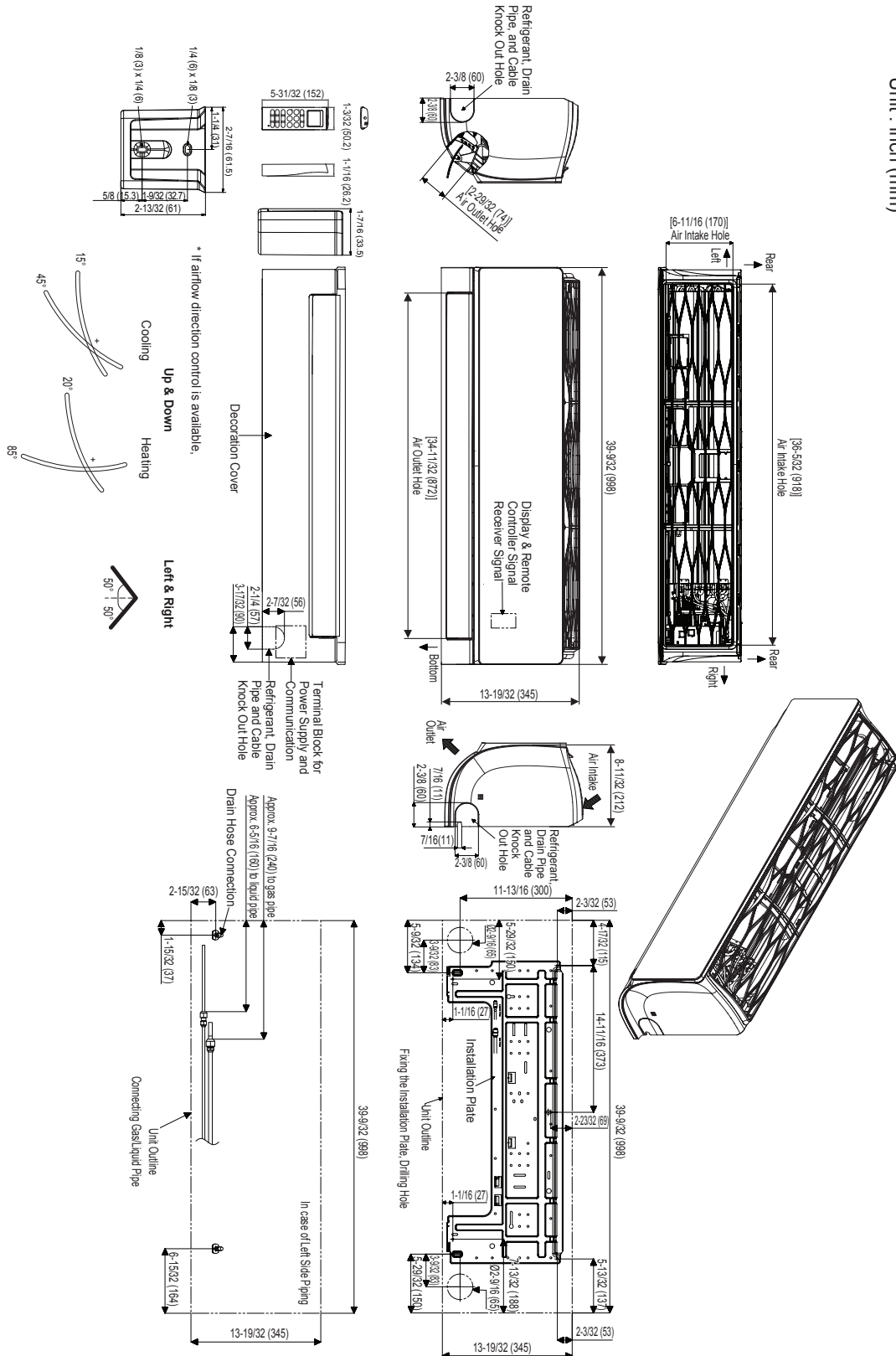

ART COOL MIRROR INDOOR UNITS

Cooling Capacity Table

MULTI F
MULTI F MAX

Table 4: Multi F Art Cool Mirror Indoor Units Cooling Capacity Table.

Model No. / Nominal Capacity of Indoor Unit (Btu/h)	Outdoor Air Temp. (°F DB)	Indoor Air Temp. °F DB / °F WB											
		68 / 57		73 / 61		77 / 64		80 / 67		86 / 72		90 / 75	
		TC	SHC	TC	SHC	TC	SHC	TC	SHC	TC	SHC	TC	SHC
LAN090HSV5 9,000	14	8.82	6.04	9.37	6.38	9.92	6.18	10.31	6.31	11.01	6.36	11.56	6.48
	20	8.82	6.09	9.36	6.43	9.91	6.23	10.31	6.36	11.01	6.41	11.55	6.53
	25	8.81	6.13	9.36	6.48	9.90	6.27	10.30	6.41	11.00	6.46	11.54	6.58
	30	8.80	6.18	9.35	6.53	9.90	6.32	10.29	6.46	10.99	6.51	11.54	6.63
	35	8.80	6.23	9.34	6.58	9.89	6.37	10.28	6.50	10.98	6.56	11.53	6.68
	40	8.79	6.28	9.33	6.63	9.88	6.42	10.27	6.55	10.97	6.61	11.52	6.73
	45	8.78	6.32	9.33	6.68	9.87	6.47	10.27	6.60	10.96	6.66	11.51	6.78
	50	8.78	6.37	9.32	6.73	9.87	6.51	10.26	6.65	10.96	6.71	11.50	6.83
	55	8.77	6.42	9.31	6.78	9.86	6.56	10.25	6.70	10.95	6.76	11.49	6.88
	60	8.76	6.46	9.31	6.83	9.85	6.61	10.24	6.75	10.94	6.81	11.48	6.93
	65	8.76	6.51	9.30	6.88	9.84	6.66	10.24	6.80	10.93	6.85	11.47	6.98
	70	8.75	6.56	9.29	6.92	9.84	6.70	10.23	6.85	10.92	6.90	11.47	7.03
	75	8.54	6.45	9.08	6.82	9.62	6.61	10.01	6.75	10.71	6.82	11.25	6.96
	80	8.33	6.34	8.87	6.71	9.41	6.51	9.80	6.66	10.49	6.73	11.03	6.87
	85	8.12	6.22	8.66	6.60	9.20	6.41	9.59	6.56	10.28	6.64	10.82	6.79
	90	7.91	6.10	8.45	6.48	8.99	6.31	9.37	6.46	10.06	6.55	10.60	6.70
	95	7.68	6.04	8.22	6.43	8.75	6.26	9.00	6.32	9.83	6.52	10.36	6.67
	100	7.50	5.88	8.03	6.26	8.57	6.11	8.88	6.22	9.64	6.37	10.17	6.53
	105	7.31	5.72	7.84	6.10	8.38	5.96	8.77	6.12	9.45	6.23	9.99	6.39
	110	7.12	5.52	7.66	5.90	8.19	5.78	8.58	5.94	9.26	6.06	9.80	6.22
115	6.94	5.36	7.47	5.74	8.01	5.63	8.39	5.79	9.08	5.91	9.61	6.08	
118	6.82	5.32	7.36	5.70	7.89	5.60	8.28	5.76	8.96	5.89	9.50	6.06	
122	6.79	5.30	7.32	5.69	7.86	5.59	8.24	5.76	8.93	5.89	9.46	6.06	
LAN120HSV5 12,000	14	11.76	8.51	12.49	8.99	13.22	8.70	13.75	8.88	14.69	8.96	15.42	9.13
	20	11.75	8.57	12.48	9.06	13.21	8.77	13.74	8.95	14.67	9.03	15.40	9.20
	25	11.75	8.64	12.48	9.13	13.20	8.84	13.73	9.02	14.66	9.10	15.39	9.27
	30	11.74	8.71	12.47	9.20	13.19	8.90	13.72	9.09	14.65	9.17	15.38	9.34
	35	11.73	8.77	12.46	9.27	13.18	8.97	13.71	9.16	14.64	9.24	15.37	9.41
	40	11.72	8.84	12.45	9.34	13.17	9.04	13.70	9.23	14.63	9.31	15.36	9.48
	45	11.71	8.90	12.44	9.41	13.16	9.11	13.69	9.30	14.62	9.38	15.35	9.55
	50	11.70	8.97	12.43	9.47	13.15	9.17	13.68	9.37	14.61	9.45	15.33	9.62
	55	11.69	9.03	12.42	9.54	13.14	9.24	13.67	9.44	14.60	9.52	15.32	9.70
	60	11.68	9.10	12.41	9.61	13.13	9.31	13.66	9.50	14.59	9.58	15.31	9.77
	65	11.67	9.17	12.40	9.68	13.12	9.38	13.65	9.57	14.57	9.65	15.30	9.84
	70	11.66	9.23	12.39	9.75	13.11	9.44	13.64	9.64	14.56	9.72	15.29	9.91
	75	11.38	9.08	12.11	9.60	12.83	9.31	13.35	9.51	14.27	9.60	15.00	9.79
	80	11.10	8.92	11.82	9.45	12.55	9.17	13.07	9.38	13.99	9.48	14.71	9.68
	85	10.83	8.76	11.54	9.29	12.26	9.03	12.78	9.24	13.70	9.36	14.42	9.56
	90	10.55	8.60	11.26	9.13	11.98	8.88	12.50	9.10	13.42	9.22	14.13	9.43
	95	10.25	8.51	10.96	9.05	11.67	8.82	12.00	8.90	13.10	9.18	13.81	9.39
	100	10.00	8.28	10.71	8.82	11.42	8.61	11.84	8.76	12.85	8.98	13.56	9.20
	105	9.75	8.05	10.46	8.59	11.17	8.40	11.69	8.62	12.60	8.78	13.31	9.01
	110	9.50	7.77	10.21	8.31	10.92	8.14	11.44	8.37	12.35	8.53	13.07	8.76
115	9.25	7.54	9.96	8.08	10.67	7.92	11.19	8.15	12.10	8.33	12.82	8.56	
118	9.10	7.49	9.81	8.03	10.52	7.88	11.04	8.12	11.95	8.30	12.67	8.54	
122	9.05	7.47	9.76	8.01	10.48	7.87	10.99	8.11	11.90	8.29	12.62	8.53	

TC = Total Capacity (kBtu/h).

SHC: Sensible Heat Capacity (kBtu/h).

Nominal capacity as rated 0 ft. above sea level and a 0 ft. level difference between outdoor and indoor units. Corresponding refrigerant piping length is accordance with standard length of each outdoor unit.

Nominal cooling capacity rating obtained with air entering the indoor unit at 80°F dry bulb (DB) and 67°F wet bulb (WB), and outdoor ambient conditions of 95°F dry bulb (DB) and 75°F wet bulb (WB).

The shaded table columns and rows indicate reference data. When operating at this temperature, these values can be different if the system is not running consistently.

Multi F and Multi F MAX Indoor Unit Engineering Manual

Table 5: Multi F Art Cool Mirror Indoor Units Cooling Capacity Table (continued).

Model No. / Nominal Capacity of Indoor Unit (Btu/h)	Outdoor Air Temp. (°F DB)	Indoor Air Temp. °F DB / °F WB											
		68 / 57		73 / 61		77 / 64		80 / 67		86 / 72		90 / 75	
		TC	SHC	TC	SHC	TC	SHC	TC	SHC	TC	SHC	TC	SHC
LAN180HSV5 18,000	14	17.65	12.33	18.74	13.02	19.84	12.61	20.63	12.88	22.03	12.98	23.12	13.23
	20	17.63	12.43	18.73	13.13	19.82	12.71	20.61	12.98	22.01	13.09	23.11	13.33
	25	17.62	12.52	18.71	13.23	19.81	12.81	20.60	13.08	22.00	13.19	23.09	13.44
	30	17.60	12.62	18.70	13.33	19.79	12.91	20.58	13.18	21.98	13.29	23.07	13.54
	35	17.59	12.71	18.68	13.43	19.78	13.00	20.57	13.28	21.96	13.39	23.05	13.64
	40	17.58	12.81	18.67	13.53	19.76	13.10	20.55	13.38	21.94	13.49	23.04	13.75
	45	17.56	12.90	18.66	13.63	19.75	13.20	20.53	13.48	21.93	13.59	23.02	13.85
	50	17.55	13.00	18.64	13.73	19.73	13.30	20.52	13.58	21.91	13.69	23.00	13.95
	55	17.54	13.10	18.63	13.83	19.72	13.39	20.50	13.68	21.89	13.79	22.98	14.05
	60	17.52	13.19	18.61	13.93	19.70	13.49	20.49	13.78	21.88	13.89	22.97	14.16
	65	17.51	13.29	18.60	14.03	19.69	13.59	20.47	13.87	21.86	13.99	22.95	14.26
	70	17.50	13.38	18.58	14.13	19.67	13.69	20.46	13.97	21.84	14.09	22.93	14.36
	75	17.08	13.16	18.16	13.92	19.24	13.49	20.03	13.79	21.41	13.92	22.50	14.20
	80	16.66	12.93	17.74	13.70	18.82	13.30	19.60	13.60	20.98	13.75	22.06	14.03
	85	16.24	12.70	17.32	13.47	18.40	13.09	19.17	13.40	20.55	13.56	21.63	13.85
	90	15.82	12.46	16.90	13.23	17.97	12.88	18.75	13.19	20.12	13.37	21.20	13.67
	95	15.37	12.33	16.44	13.12	17.51	12.78	18.00	12.90	19.65	13.30	20.72	13.61
	100	14.99	12.00	16.06	12.78	17.13	12.47	17.77	12.70	19.28	13.01	20.35	13.33
105	14.62	11.67	15.69	12.45	16.76	12.17	17.53	12.50	18.90	12.73	19.97	13.05	
110	14.24	11.27	15.32	12.05	16.39	11.79	17.16	12.13	18.53	12.36	19.60	12.70	
115	13.87	10.93	14.94	11.71	16.01	11.48	16.79	11.82	18.15	12.07	19.22	12.41	
118	13.65	10.85	14.72	11.64	15.79	11.42	16.56	11.77	17.93	12.03	19.00	12.37	
122	13.57	10.83	14.64	11.62	15.71	11.40	16.49	11.75	17.85	12.01	18.92	12.36	

TC = Total Capacity (kBtu/h).

SHC: Sensible Heat Capacity (kBtu/h).

Nominal capacity as rated 0 ft. above sea level and a 0 ft. level difference between outdoor and indoor units. Corresponding refrigerant piping length is accordance with standard length of each outdoor unit.

Nominal cooling capacity rating obtained with air entering the indoor unit at 80°F dry bulb (DB) and 67°F wet bulb (WB), and outdoor ambient conditions of 95°F dry bulb (DB) and 75°F wet bulb (WB).

The shaded table columns and rows indicate reference data. When operating at this temperature, these values can be different if the system is not running consistently.

ART COOL MIRROR INDOOR UNITS

Heating Capacity Table

MULTI F
MULTI F MAX

Table 6: Multi F Art Cool Mirror Indoor Units Heating Capacity Table.

Model No. / Nominal Capacity of Indoor Unit (Btu/h)	Outdoor Air Temp.		Indoor Air Temp. °F DB					
	°F DB	°F WB	61	64	68	70	72	75
			TC	TC	TC	TC	TC	TC
LAN090HSV5 10,900	0	-0.4	5.61	5.53	5.48	5.45	5.37	5.14
	5	4.5	6.32	6.24	6.18	6.16	6.08	5.85
	10	9	7.03	6.95	6.90	6.88	6.79	6.56
	17	15	7.98	7.90	7.85	7.82	7.75	7.48
	20	19	8.33	8.26	8.21	8.18	8.09	7.82
	25	23	8.93	8.85	8.79	8.77	8.69	8.37
	30	28	9.44	9.36	9.31	9.29	9.20	8.93
	35	32	9.96	9.87	9.82	9.79	9.72	9.47
	40	36	10.42	10.33	10.28	10.25	10.18	9.94
	45	41	10.87	10.80	10.74	10.71	10.64	10.40
	47	43	11.06	10.98	10.93	10.90	10.82	10.59
	50	46	11.24	11.15	11.10	11.08	10.99	10.73
	55	51	11.53	11.46	11.40	11.37	11.30	10.98
	60	56	11.53	11.46	11.40	11.37	11.30	11.03
	63	59	11.53	11.46	11.40	11.37	11.30	11.06
68	64	11.53	11.46	11.40	11.37	11.30	11.11	
LAN120HSV5 13,600	0	-0.4	7.00	6.90	6.83	6.80	6.70	6.50
	5	4.5	7.89	7.78	7.71	7.69	7.59	7.40
	10	9	8.78	8.67	8.60	8.58	8.48	8.31
	17	15	9.95	9.86	9.79	9.76	9.67	9.47
	20	19	10.40	10.30	10.23	10.20	10.10	9.90
	25	23	11.14	11.03	10.96	10.95	10.85	10.60
	30	28	11.78	11.67	11.60	11.59	11.49	11.30
	35	32	12.42	12.31	12.24	12.21	12.13	11.99
	40	36	13.00	12.89	12.82	12.79	12.70	12.58
	45	41	13.56	13.46	13.39	13.36	13.28	13.16
	47	43	13.80	13.70	13.63	13.60	13.50	13.40
	50	46	14.02	13.91	13.84	13.82	13.72	13.59
	55	51	14.39	14.29	14.22	14.19	14.10	13.90
	60	56	14.39	14.29	14.22	14.19	14.10	13.96
	63	59	14.39	14.29	14.22	14.19	14.10	14.00
68	64	14.39	14.29	14.22	14.19	14.10	14.06	
LAN180HSV5 21,600	0	-0.4	11.11	10.96	10.85	10.80	10.64	10.18
	5	4.5	12.52	12.37	12.26	12.21	12.06	11.58
	10	9	13.93	13.77	13.67	13.61	13.46	12.99
	17	15	15.81	15.65	15.55	15.49	15.34	14.84
	20	19	16.51	16.36	16.25	16.20	16.04	15.49
	25	23	17.69	17.53	17.43	17.37	17.22	16.59
	30	28	18.70	18.55	18.44	18.39	18.24	17.69
	35	32	19.72	19.56	19.46	19.41	19.25	18.79
	40	36	20.63	20.48	20.37	20.32	20.17	19.70
	45	41	21.55	21.39	21.29	21.24	21.08	20.61
	47	43	21.91	21.76	21.65	21.60	21.44	20.98
	50	46	22.26	22.11	22.01	21.95	21.80	21.27
	55	51	22.86	22.70	22.59	22.53	22.38	21.76
	60	56	22.86	22.70	22.59	22.53	22.38	21.85
	63	59	22.86	22.70	22.59	22.53	22.38	21.91
68	64	22.86	22.70	22.59	22.53	22.38	22.02	

TC = Total Capacity (kBtu/h).

Nominal capacity as rated 0 ft. above sea level and a 0 ft. level difference between outdoor and indoor units. Corresponding refrigerant piping length is accordance with standard length of each outdoor unit. Nominal heating capacity rating obtained with air entering the indoor unit at 70°F dry bulb (DB) and 60°F wet bulb (WB), and outdoor ambient conditions of 47°F dry bulb (DB) and 43°F wet bulb (WB).

Multi F and Multi F MAX Indoor Unit Engineering Manual

Figure 4: Sound Pressure Level Measurement Location.

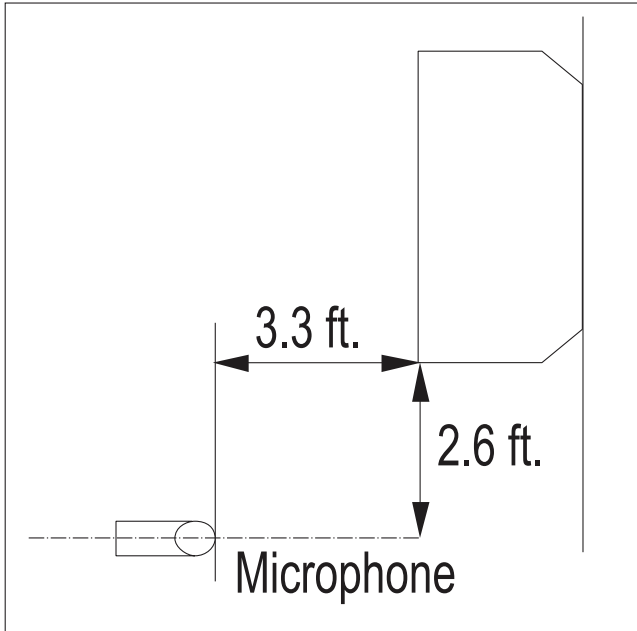

- Measurement taken 2.6' below the bottom of the unit and at a distance of 3.3' from face of unit.
- Measurements taken with no attenuation and units operating at full load normal operating condition.
- Sound level will vary depending on a range of factors such as construction (acoustic absorption coefficient) of particular area in which the equipment is installed.
- Sound power levels are measured in dB(A)±1.
- Tested in anechoic chamber per ISO Standard 3745.

Table 7: Sound Pressure Levels (dB[A]).

Model No.	Sound Pressure Levels (dB[A]) (Cooling and Heating)		
	High Fan Speed	Medium Fan Speed	Low Fan Speed
LAN090HSV5	36	32	27
LAN120HSV5	38	34	29
LAN180HSV5	44	38	34

Figure 5: Sound Pressure Level Diagrams.

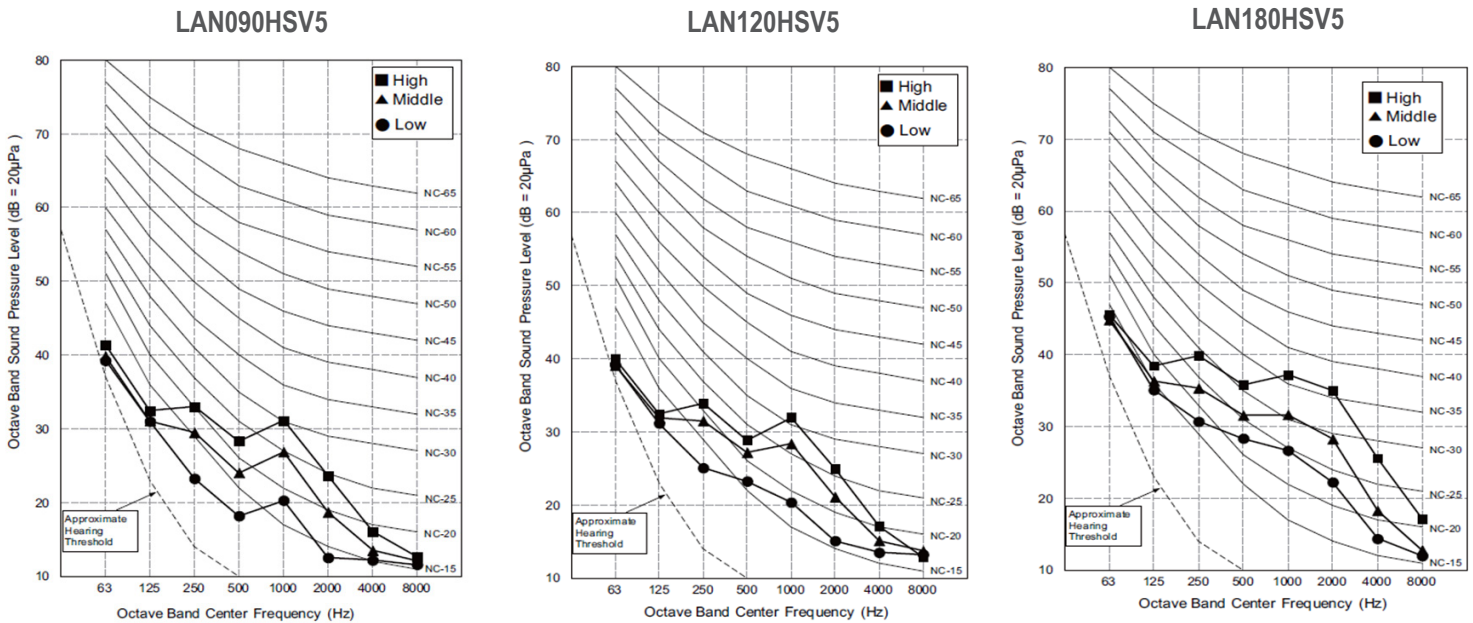

ART COOL MIRROR INDOOR UNITS

Air Velocity and Temperature Distribution

MULTI F
MULTI F MAX

Figure 6: LAN090HSV5 and LAN120HSV5 Air Velocity and Temperature Distribution Charts.

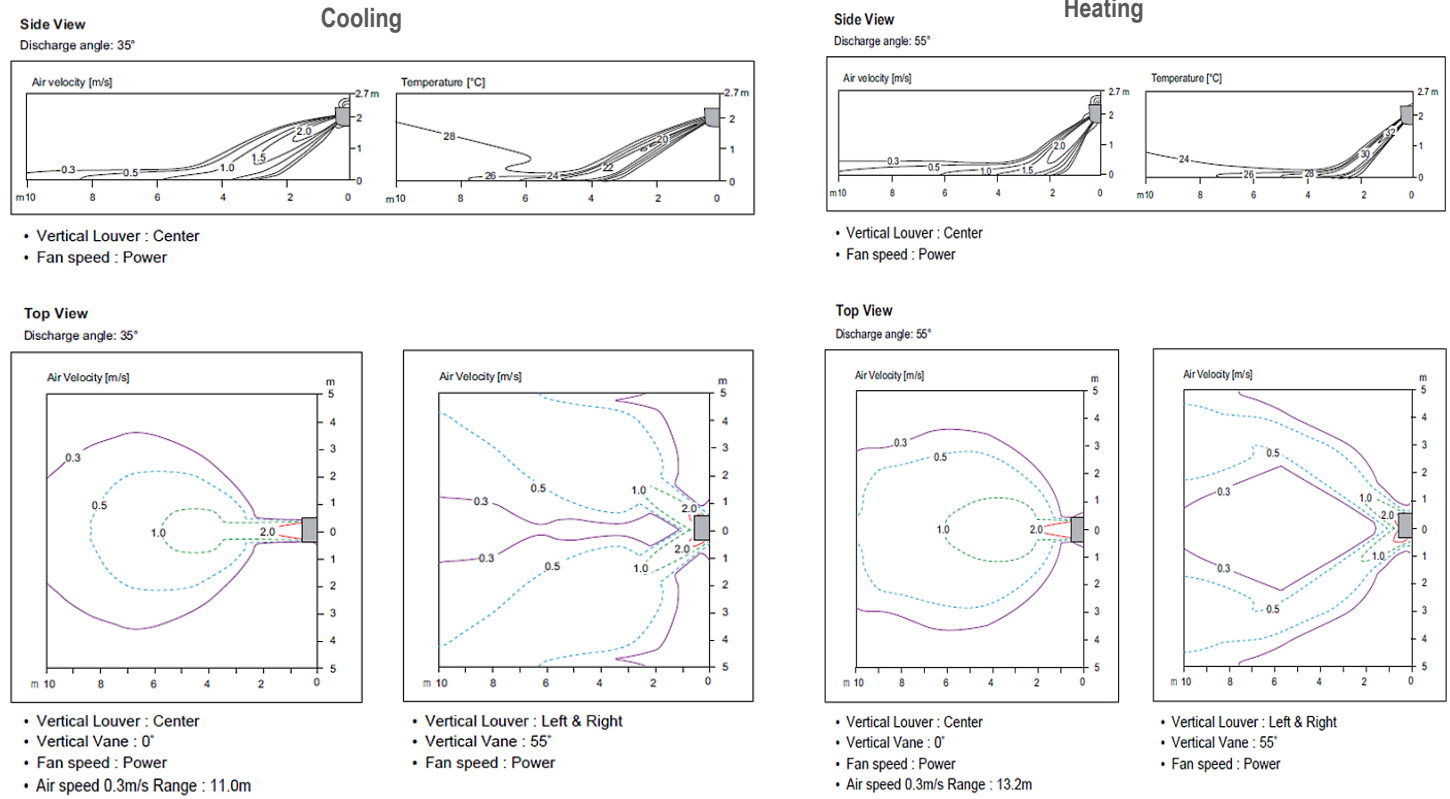

Figure 7: LAN180HSV5 Air Velocity and Temperature Distribution Charts.

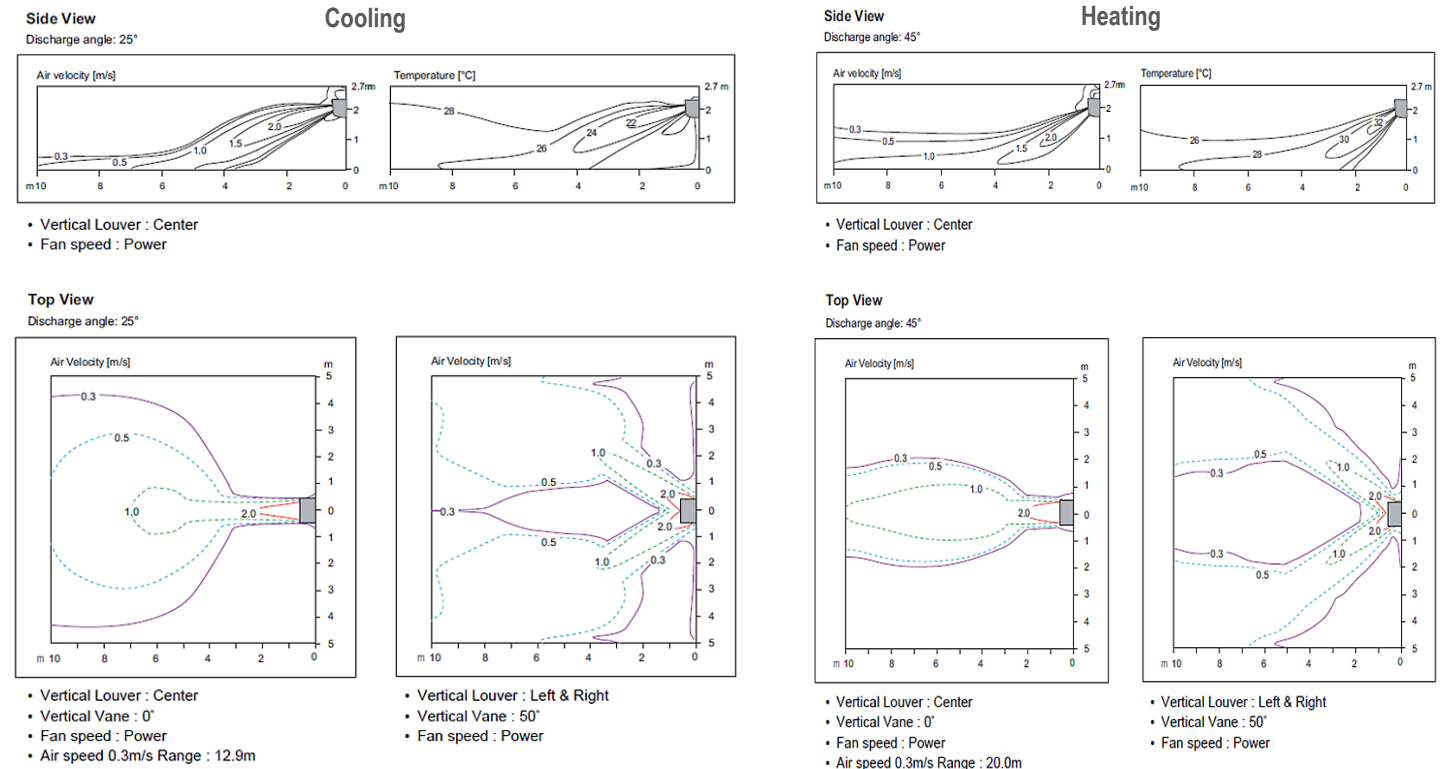

Figure 8: Art Cool Mirror Indoor Unit Refrigerant Flow Diagram.

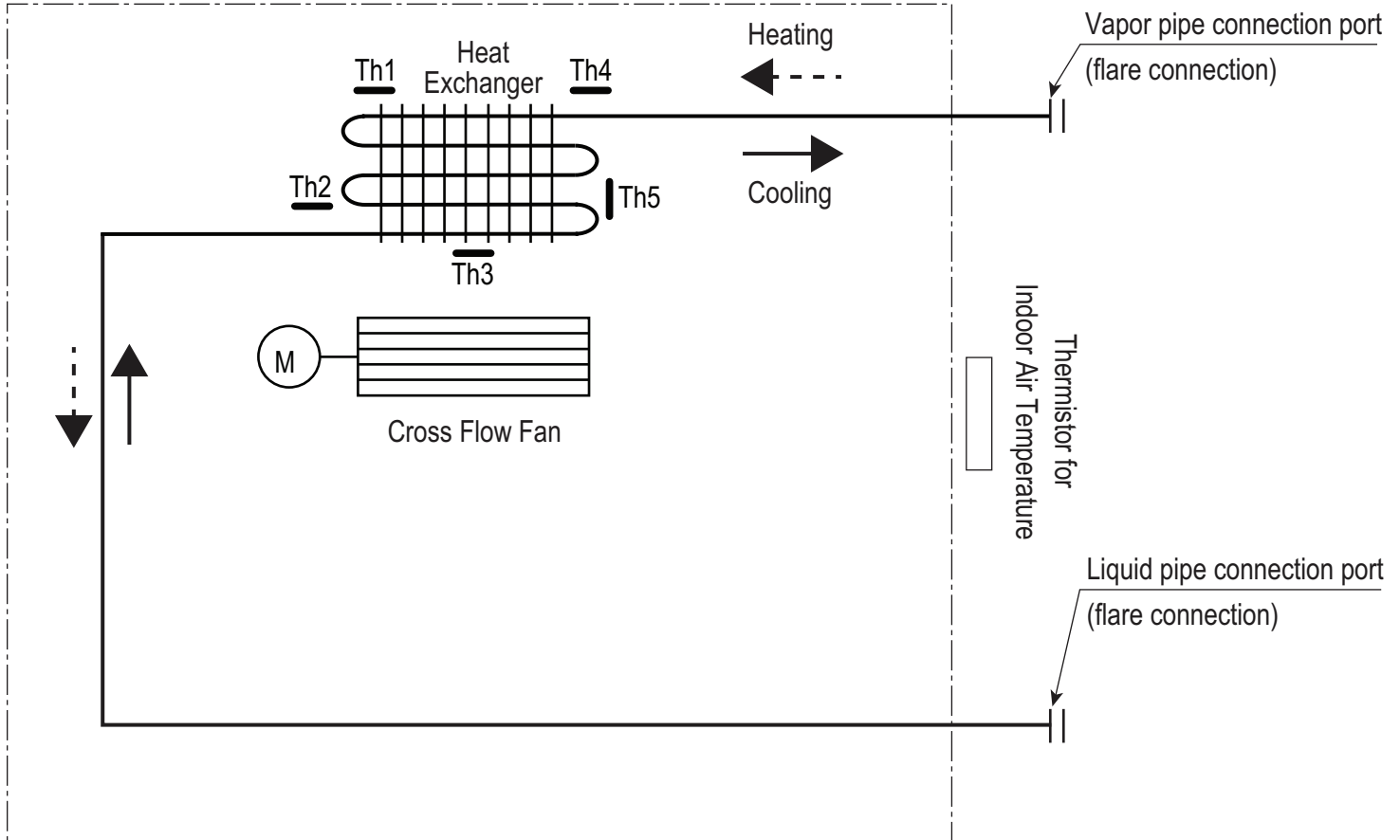

Table 8: Art Cool Mirror Indoor Unit Refrigerant Pipe Sizes.

Indoor Unit Capacity	Vapor Line Size (in., OD)	Liquid Line Size (in., OD)
9,000 Btu/h	Ø3/8	Ø1/4
12,000 Btu/h		
18,000 Btu/h	Ø1/2	

Table 9: Art Cool Mirror Indoor Unit Refrigerant Pipe Connections

Indoor Unit Capacity	Vapor Line Connection (in., OD)	Liquid Line Connection (in., OD)
9,000 Btu/h	Ø3/8	Ø1/4
12,000 Btu/h		
18,000 Btu/h	Ø5/8	Ø3/8

Table 10: Art Cool Mirror Indoor Unit Thermistor Details.

Location	Description (Based on Cooling Mode)	IDU PCB Connector
Th1	Indoor Air Temperature Thermistor	CN-TH1
Th2	Evaporator Inlet Temperature Thermistor	
Th3	Evaporator Middle Temperature Thermistor	CN-TH2
Th4	Evaporator Outlet Temperature Thermistor	
Th5	Water Level Sensor (Optional)	CN-TH3

ART COOL MIRROR INDOOR UNITS

Wiring Diagram

MULTI F
MULTI F MAX

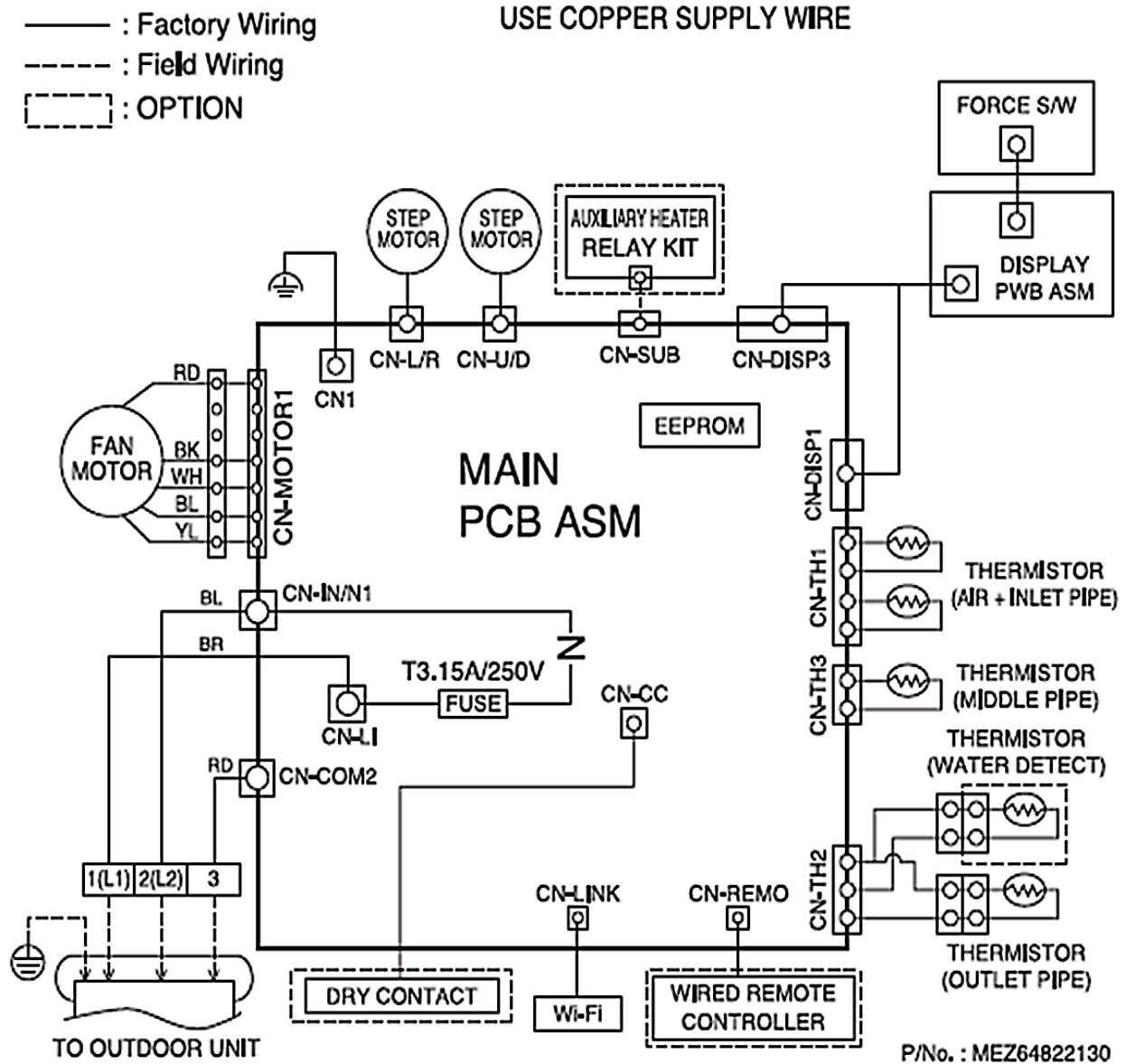
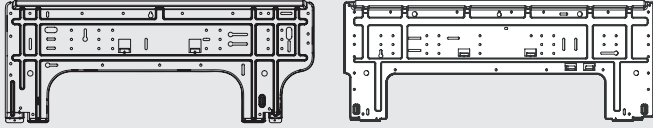
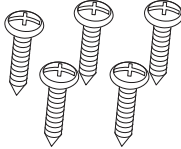
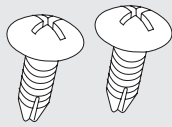

Figure 9: Multi F Art Cool Mirror LAN090HSV5, LAN120HSV5, and LAN180HSV5 Indoor Units Wiring Diagram.



Multi F and Multi F MAX Indoor Unit Engineering Manual

Factory Supplied Parts

Table 11: Parts Table.

Part	Quantity	Image
Installation Plate	One (1)	 <p>LAN090HSV5 and LAN120HSV5 LAN180HSV5</p>
Type "A" Screws	Five (5)	
Type "B" Screws (M4 x 12L)	Two (2)	
Wireless Handheld Controller with Holder AKB74955602	One (1)	

Factory Supplied Materials

- Owner's Manual
- Installation Manual

Required Tools

- Level
- Screwdriver
- Electric drill
- Hole core drill
- Flaring tool set
- Spanner (Half union)
- Thermometer

⚠ WARNING

Installation work must be performed by trained personnel and in accordance with national wiring standards and all local or other applicable codes. Improper installation can result in fire, electric shock, physical injury, or death.

Note:

Read all instructions before installing this product. Become familiar with the unit's components and connections, and the order of installation. Incorrect installation can degrade or prevent proper operation.

ART COOL MIRROR INDOOR UNITS

Installation and Best Layout Practices

MULTI F
MULTI F MAX

⚠ DANGER

To avoid the possibility of fire, do not install the unit in an area where combustible gas may generate, flow, stagnate, or leak. Failure to do so will cause serious bodily injury or death. Before beginning installation, read the safety summary at the beginning of this manual.

Select a location for installing the wall-mounted indoor unit (IDU) that meets the following conditions:

- Where there is enough structural strength to bear the weight of the unit
- Where air circulation will not be blocked
- Where noise prevention is taken into consideration
- Ensure there is sufficient space from the ceiling and floor
- Locate the indoor unit in a location where it can be easily connected to the outdoor unit/branch distribution unit
- Include space for drainage to ensure condensate flows properly out of the unit when it is in cooling mode
- Use a level indicator to ensure the unit is installed on a level plane

Note:

The unit may be damaged, may malfunction, and/or will not operate as designed if installed in any of the following conditions:

- ⊘ Do not install the unit where it will be subjected to direct thermal radiation from other heat sources.
- ⊘ Do not install the unit in an area where combustible gas may generate, flow, stagnate, or leak.
- ⊘ Do not install the unit in a location where acidic solution and spray (sulfur) are often used.
- ⊘ Do not use the unit in environments where oil, steam, or sulfuric gas are present.
- ⊘ Do not install additional ventilation products on the chassis of the unit.
- ⊘ Do not install the unit near high-frequency generator sources.
- ⊘ Do not install the unit near a doorway.

Installing in an Area Exposed to Unconditioned Air

In some installation applications, areas (floors, walls) in some rooms may be exposed to unconditioned air (room may be above or next to an unheated garage or storeroom). To countermeasure:

- Verify that carpet is or will be installed (carpet may increase the temperature by three degrees).
- Add insulation between the floor joists.
- Install radiant heat or another type of heating system to the floor.

Required Clearances

Figure 10 shows required clearance distances around a typical installed wall-mounted unit.

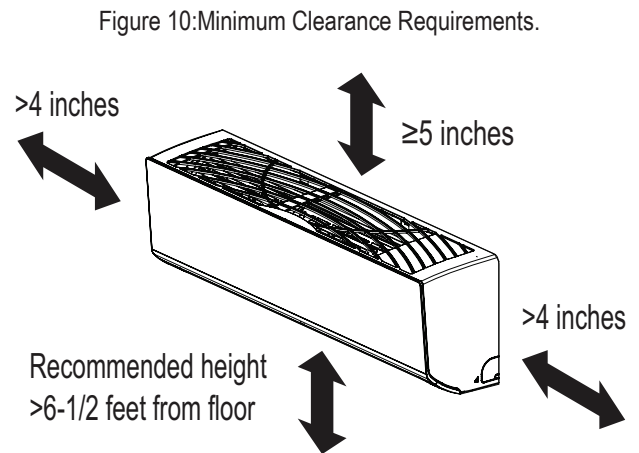

Figure 10: Minimum Clearance Requirements.

Mounting the Installation Plate

The mounting wall should be strong and solid enough to protect the unit from vibration.

- Mount the installation plate on the wall using the Type "A" screws. If mounting the unit on concrete, consider using anchor bolts.
- Always mount the installation plate horizontally. Measure the wall and mark the centerline using thread and a level.

Figure 11: Installation Plate for LAN090HSV5 and LAN120HSV5 Units.

Figure 12: Installation Plate for LAN180HSV5 Units.

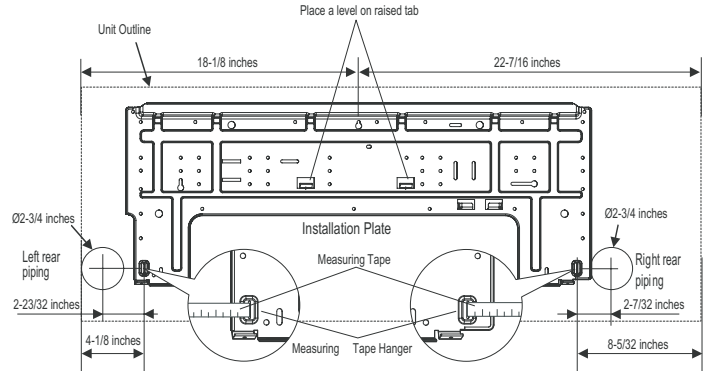
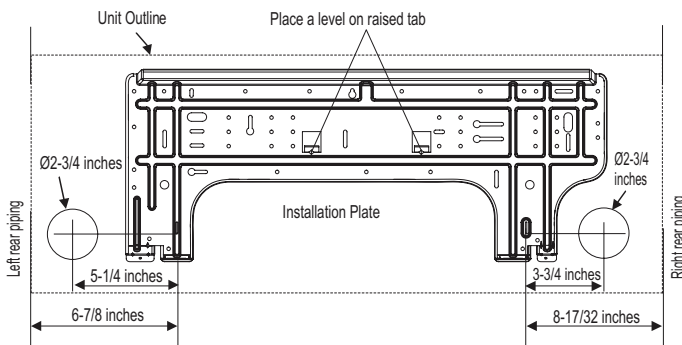

Drilling Piping Hole in the Wall

⚠ WARNING

Use caution when drilling holes through walls. Drilling into power wiring in the wall can cause serious bodily injury or death.

Follow the left or right piping clearance recommendations in Figure 3 or Figure 4.

1. Using a 2-5/8 (ø 65mm) inch hole core drill bit, drill a hole at either the right or left side of the wall mounting. The hole should slant 3/16" to 5/16" from level (upward on the indoor unit side and downward on the outdoor unit side).
2. Finish off the newly drilled hole as shown with bushing and sleeve covering. Sleeve and bushing prevents damage to the tubing/bundling of the piping.

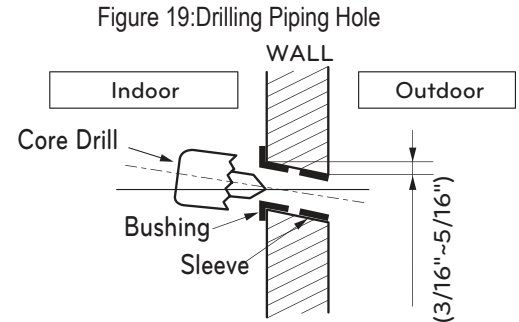

Hanging the Indoor Unit Chassis

1. Attach the three (3) hooks on the top of the indoor unit to the top edge of the installation plate. Verify the hooks are properly attached to the installation plate by gently shaking the indoor unit from side to side.
2. Unlock the tubing clamp from the indoor unit frame. For easier access between the bottom of the indoor unit and the wall, prop the clamp between the indoor unit frame and installation plate.
3. Remove the screw covers at the bottom of the indoor unit, unscrew the two (2) screws, remove the frame cover, remove the piping connection cover, and position the piping for installation (down, back, left, or right).

Figure 13: Locking the Indoor Unit onto the Installation Plate.

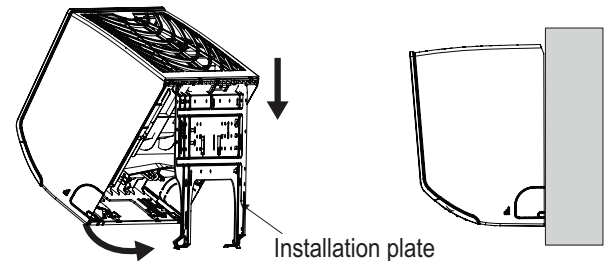

Figure 14: Accessing the Back of the Indoor Unit.

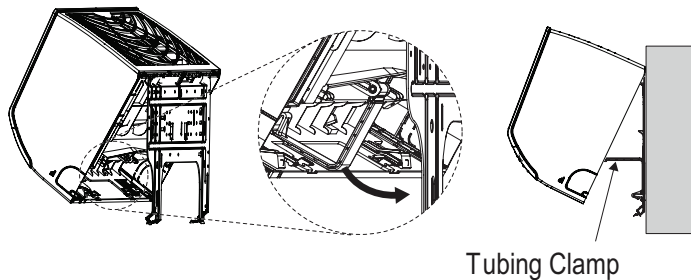

Figure 15: Removing the Frame Cover.

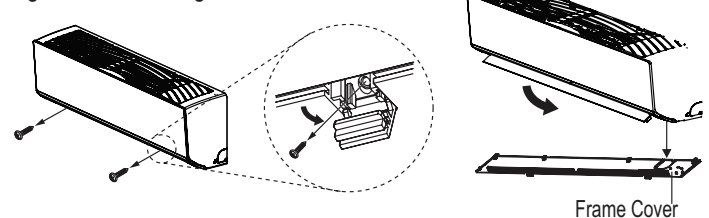

Figure 16: Exterior Back View of Indoor Unit.

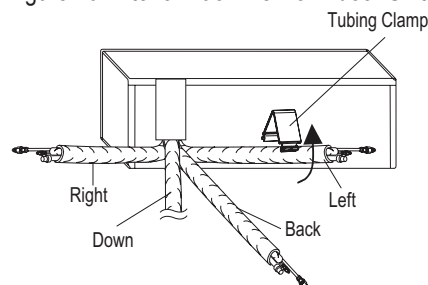

Figure 17: Piping Installed to the Left.

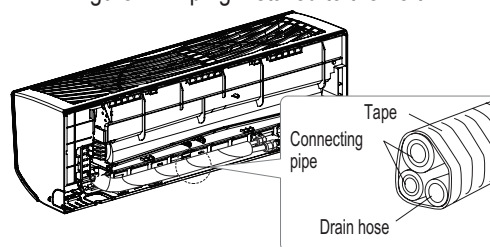
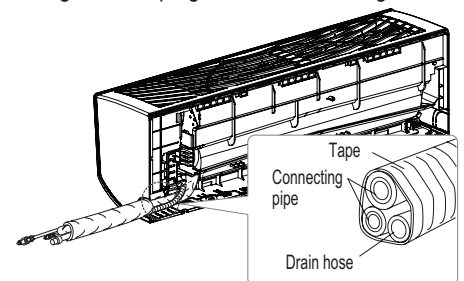

Figure 18: Piping Installed to the Right.



ART COOL MIRROR INDOOR UNITS

Installation and Best Layout Practices

MULTI F
MULTI F MAX

Power Wiring / Communications Cable Guidelines

- Follow manufacturer's circuit diagrams in the technical manuals.
- Confirm power source specifications.
- Confirm that the electrical capacity is sufficient.
- Starting current must be maintained ± 10 percent of the rated current marked on the outdoor unit name plate.
- Confirm cable thickness specifications.
- It is recommended that a circuit breaker is installed, especially if conditions could become wet or moist.
- Include a disconnect in the power wiring system, add an air gap contact separation of at least 1/8 inch in each active (phase) conductor.

⚠ WARNING

- Loose wiring may cause unit to malfunction, overheat, and catch fire, resulting in severe injury or death.

Note:

- Terminal screws may become loose during transport. Properly tighten the terminal connections during installation.
- A voltage drop may cause the following problems:
 - Magnetic switch vibration, fuse breaks, or disturbance to the normal function of an overload protection device.
 - Compressor will not receive the proper starting current.

Connecting the Power Wiring and Communications Cable

1. Insert the power wiring/communications cable from the outdoor unit or branch distribution unit (Multi F MAX systems only) through the bottom of the indoor unit.
2. Connect each wire to its appropriate terminal on the indoor unit control board. Verify that the color and terminal numbers from the outdoor unit or branch distribution unit (Multi F MAX systems only) wiring match the color and terminal numbers on the indoor unit.
3. Secure the power wiring/communications cable with the cable restraint.

Figure 20: Connecting the Power Wiring / Communications Cable.

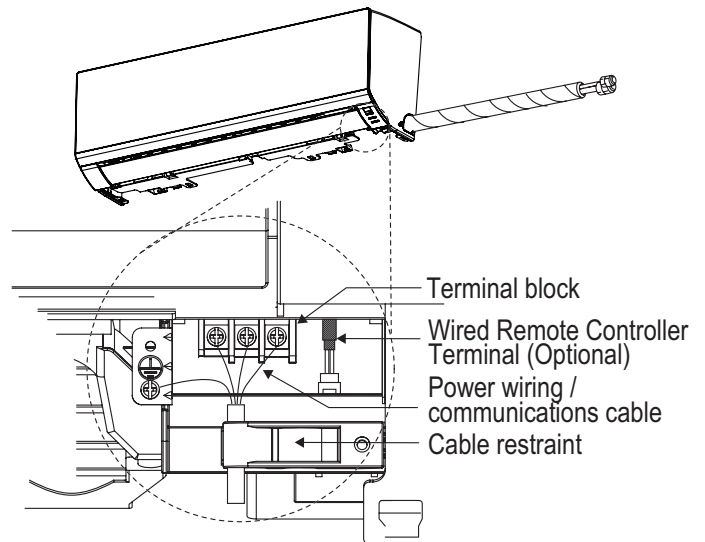

Figure 21: Simplified View of Indoor Unit to Outdoor Unit / Branch Distribution Unit Terminal Connections—LAN090HSV5 and LAN120HSV5 models.

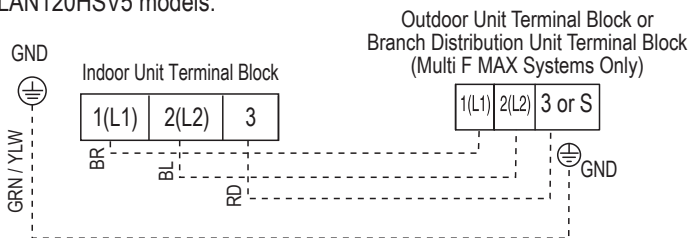
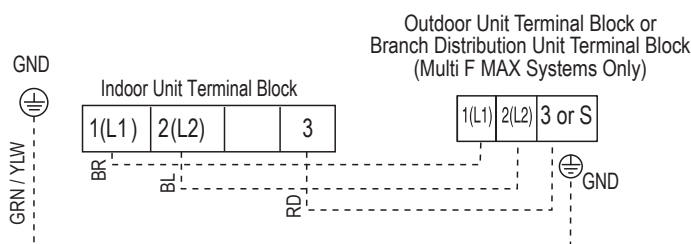

Figure 22: Simplified View of Indoor Unit to Outdoor Unit / Branch Distribution Unit Terminal Connections—LAN180HSV5 models.



Wireless Handheld Controller

Figure 23:AKB74955602 Wireless Controller.

Table 12: AKB74955602 Wireless Controller Functions.

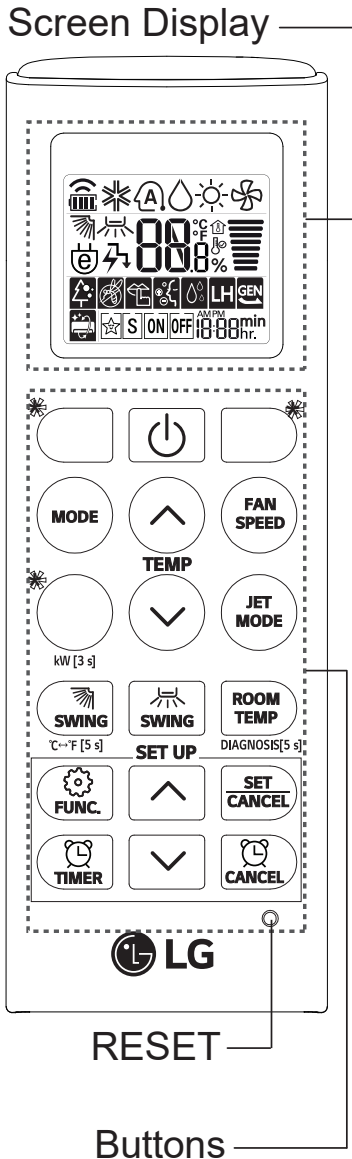

Button	Display Screen	Description
		To purify the air by removing particles that enters the indoor unit.
		To reduce noise from outdoor units.
		To keep your skin moisturized by generating ion clusters.
		To lower indoor humidity quickly.
		To maintain a minimum indoor temperature and prevent indoor objects from freezing.
		To fan away a mosquito.
		To remove moisture generated inside the indoor unit.
		To make the comfortable sleep environment.
RESET	-	To Initialize the remote control settings.

Button	Display Screen	Description
	-	To turn on/off the air conditioner.
	88.8	To adjust the desired room temperature in cooling, heating or auto changeover mode.
MODE		To select the cooling mode.
		To select the heating mode.
		To select the dehumidification mode.
		To select the fan mode.
		To select the auto changeover/auto operation mode.
JET MODE	Po	To change room temperature quickly.
FAN SPEED		To adjust the fan speed.
		To adjust the air flow direction vertically or horizontally.
		To turn on/off air conditioner automatically at desired time.
SET/CANCEL	-	To set/cancel the special functions and timer.
	-	To cancel the timer settings.
	-	To adjust time.
*LIGHT OFF	-	To set the brightness of the display on the indoor unit.
ROOM TEMP		To display the room temperature.
°C ↔ °F [5 s]	°C °F	To change unit between °C and °F.
*ENERGY SAVING		To minimize power consumption.
*COMFORT AIR		To adjust the air flow to deflect wind.
kW[3 s]	-	To set whether or not to display information regarding energy.
*ENERGY CTRL		To bring the effect of the power saving.
*COMFORT SLEEP		To make the comfortable sleep environment.
DIAGNOSIS [5 s]	-	To conveniently check maintenance information of a product.

ART COOL MIRROR INDOOR UNITS

Installation and Best Layout Practices

MULTI F
MULTI F MAX

Wired Controller Connections

Figure 24: Wired Controller Connection on the Indoor Unit Terminal Block—LAN090HSV5 and LAN120HSV5 models.

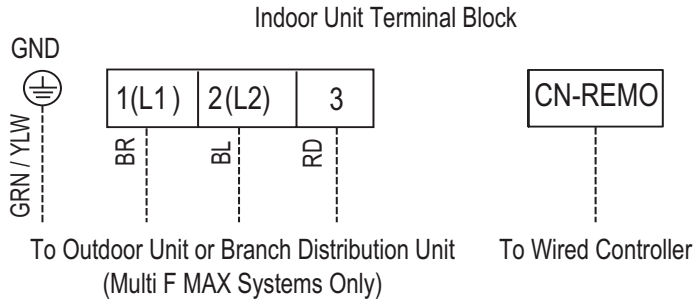
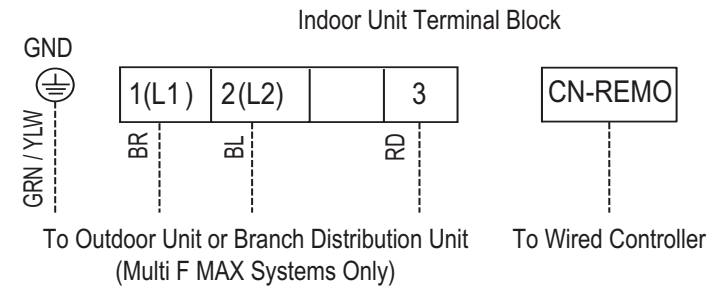

Figure 25: Wired Controller Connection on the Indoor Unit Terminal Block—LAN180HSV5 models.



Wired Controller Placement

Wired controllers include a sensor to detect room temperature. To maintain comfort levels in the conditioned space, the wired controller must be installed in a location away from direct sunlight, high humidity, and where it could be directly exposed to cold air. Controller must be installed four (4) to five (5) feet above the floor where its LED display can be read easily, in an area with good air circulation, and where it can detect an average room temperature.

- Do not install the wired controller near or in:
- Drafts or dead spots behind doors and in corners
 - Hot or cold air from ducts
 - Radiant heat from the sun or appliances
 - Concealed pipes and chimneys
 - An area where temperatures are uncontrolled, such as an outside wall

Figure 26: Proper Location for the Wired Controller.

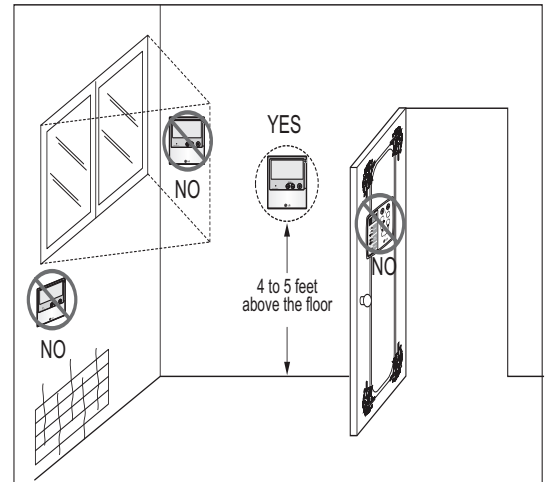

Operation Mode Sequence

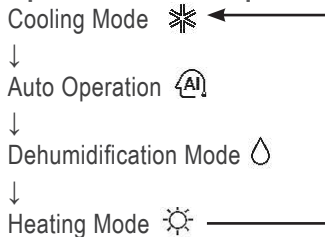

Hanging the Wired Controller

1. The controller wiring/cable can be installed in one of three directions: top, back, or on the right side. If top or right side installation is desired, remove cable guide grooves on the controller, and then position wiring/cable on applicable side.
2. Choose and mark the area of installation, and then screw the wall plate into place (using the provided parts). Install the controller wall plate to fit the electrical box if one is present. Ensure that no gaps exist between the wall plate and the wall itself.
3. Arrange wiring/cables so as not to interfere with the controller circuitry. Position the wired controller on the wall plate. Snap into place by pressing the bottom part of the wired controller onto the wall plate. Make sure that no gaps exist between the wired controller and the wall plate on all sides.
4. To remove wired controller from the wall plate, insert a screwdriver into the two holes at the bottom. Twist screwdriver to release controller. Do not damage the controller components when removing.

Figure 27: Removing the Cable Guide Grooves.

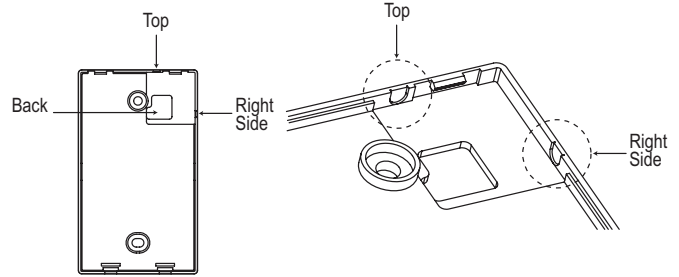

Figure 28: Attaching the Wall Plate.

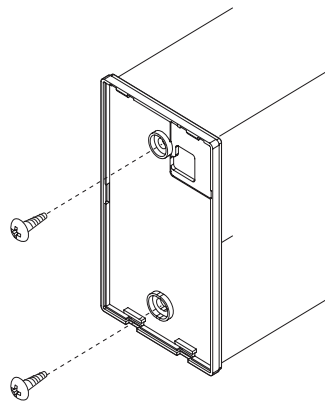
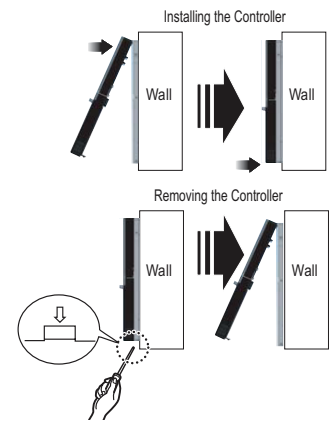

Figure 29: Installing/Removing the Controller.



Assigning the Thermistor for Temperature Detection

Each indoor unit includes a return air thermistor assigned to sense the temperature. If a wired controller is installed, there is a choice of sensing temperature with either the indoor unit return air thermistor or the thermistor in the wired controller. It is also an option to set both thermistors to sense temperature so that indoor unit bases its operation on the first thermistor to reach the designated temperature differential. For applicable indoor units, an optional Remote Temperature Sensor can be used in lieu of the return air thermistor—either alone or in conjunction with a wired controller thermistor as previously described.

ART COOL™ GALLERY INDOOR UNIT DATA

“Mechanical Specifications” on page 29

“General Data / Specifications” on page 30

“Dimensions” on page 31

“Cooling Capacity Table” on page 32

“Heating Capacity Table” on page 33

“Acoustic Data” on page 34

“Air Velocity and Temperature Distribution” on page 35

“Refrigerant Flow Diagram” on page 36

“Wiring Diagram” on page 37

“Factory Supplied Parts and Materials” on page 38

“Installation and Best Layout Practices” on page 39

ART COOL Gallery Indoor Units

General

All LG indoor units are factory assembled, wired, piped, and provided with a control circuit board, fan, and motor. Art Cool Gallery indoor units have a sound rating no higher than 42 dB(A) as tested per KSA0701 ISO Standard 3745.

Coil

Indoor unit coils are comprised of a minimum of two rows of aluminum fins mechanically bonded to copper tubing. The coils are pressure tested at the factory. Each unit is provided with a factory installed condensate drain pan below the coil.

Refrigerant System

System is designed for use with R410A refrigerant. The refrigeration circuit is pressure-tested at the factory and shipped with a holding charge of helium gas. Refrigerant pipe connections are 45° flare. All refrigerant lines from the outdoor unit to the indoor units must be field insulated.

Electrical

Each indoor unit is designed to operate using 208–230/60/1 power with voltage variances of ±10%.

Casing

Units are designed to mount on a vertical surface, and are shipped with a separate back plate that secures the unit to the wall, protruding no more than six (6) inches. Unit is designed so that refrigerant piping can be installed in one of four different directions.

Cases / Finishes

The Art Cool Gallery unit has a frame that can accommodate a 20" x 20" photograph, picture or artwork. Unit casing has a gray finish and is manufactured of heavy-duty acrylonitrile butadiene styrene (ABS) and high impact polystyrene (HIPS) plastic.

Fan Assembly and Control

The unit has a single, direct-drive, crossflow fan made of high strength ABS plastic. The fan motor is brushless digitally controlled (BLDC) with permanently lubricated and sealed ball bearings. The fan/motor assembly is mounted on vibration attenuating rubber grommets. Fan speed is controlled using a microprocessor-based direct digitally controlled algorithm that provides pre-programmed, field-selectable fixed or auto fan speeds in the Heating and Cooling modes. For Art Cool Gallery units, the indoor fan has Low, Med, High, Power Cool and Auto settings for Cooling mode; and has Low, Med, High, and Auto settings for Heating mode. The Auto setting adjusts the fan speed based on the difference between the controller setpoint and space temperature. Also, the separate Chaos setting provides a simultaneous and random change in fan speed and flow

Features

- Inverter (Variable speed fan)
- Chaos swing
- Jet cool
- Group control
- Self-cleaning indoor coil
- Auto operation / auto restart operation
- 24-Hour on/off timer
- Wireless LCD remote control included; wired thermostat available (sold separately)

direction at the discharge, simulating a natural outdoor breeze.

Air Filter

Return air is filtered with a factory-supplied, removable, washable pre-filter. Filter access is from the front of the unit without the use of tools.

Airflow Guide Vanes

Motorized oscillating guide vanes are factory installed, and allows the ability to control the direction of airflow from side to side. A motorized air sweep louver provides an automatic change in airflow by directing the air up and down to provide uniform air distribution.

Microprocessor Control

The indoor unit is provided with an integrated control panel to communicate with the outdoor unit. All unit operation parameters are stored in non-volatile memory resident on the unit microprocessor. The microprocessor controls space temperature through using the value provided by the temperature sensor within the indoor unit. The microprocessor control will activate indoor unit operation when the indoor room temperature falls below or rises above a setpoint temperature, at which point, a signal is sent to the outdoor unit to begin the appropriate mode. The microprocessor will also provide self-diagnostics and auto restart functions. A field-supplied four-wire power / communications cable must be installed to connect the indoor unit(s) to the outdoor unit.

Controls

The indoor unit casing has a factory-standard, integral infrared sensor designed to communicate with the supplied LG wireless handheld remote controller. An optional LG supplied LG wired controller is available as an additional accessory. Communication between the indoor units and the outdoor unit is accomplished through 18 AWG, four-core, stranded and shielded power / communication cable.

Condensate

The unit is designed for gravity draining of condensate and includes a flexible drain hose capable of installation in one of two directions. Unit includes a connection that is compatible with the AquaGuard® AG-9300-LG condensate sensor.

Figure 30: Multi F Art Cool Gallery Indoor Unit.



ART COOL GALLERY INDOOR UNITS

General Data / Specifications

MULTI F
MULTI F MAX

Table 13: Multi F Art Cool Gallery Indoor Unit General Data.

Model Name	LMAN097HVP	LMAN127HVP
Nominal Cooling Capacity (Btu/h) ¹	9,000	11,200
Nominal Heating Capacity (Btu/h) ¹	10,400	13,300
<i>Operating Range</i>		
Cooling (°F WB)	57-77	57-77
Heating (°F DB)	59-81	59-81
<i>Fan</i>		
Type	Turbo	Turbo
Motor Output (W) x Qty.	24 x 1	24 x 1
Motor/Drive	Brushless Digitally Controlled / Direct	Brushless Digitally Controlled / Direct
Airflow Rate CFM (H/M/L)	272 / 208 / 155	314 / 258 / 198
<i>Unit Data</i>		
Refrigerant Type ²	R410A	R410A
Refrigerant Control	EEV	EEV
Power Supply V, Ø, Hz ³	208-230, 1, 60	208-230, 1, 60
Rated Amps (A)	0.2	0.2
Sound Pressure Level ±3 dB(A) (H/M/L) ⁴	39 / 35 / 31	42 / 38 / 34
Dimensions (W x H x D, in.)	23-5/8 x 23-5/8 x 5-25/32	23-5/8 x 23-5/8 x 5-25/32
Net Unit Weight (lbs.)	32	32
Shipping Weight (lbs.)	37	37
Power Wiring / Communications Cable (No. x AWG) ⁵	4 x 18	4 x 18
Heat Exchanger (Row x Column x Fin / inch) x Number	(2 x 20 x 21) x 1	(2 x 20 x 21) x 1
<i>Piping</i>		
Liquid (in.)	1/4	1/4
Vapor (in.)	3/8	3/8
Drain O.D. / I.D. (in.)	27/32, 5/8	27/32, 5/8

¹Nominal capacity is rated 0 ft. above sea level with corresponding refrigerant piping length in accordance with standard length of each outdoor unit and a 0 ft. level difference between outdoor and indoor units. All capacities are net with a combination ratio between 95 – 105%.

Nominal cooling capacity rating obtained with air entering the indoor unit at 80°F dry bulb (DB) and 67°F wet bulb (WB) and outdoor ambient conditions of 95°F dry bulb (DB) and 75°F wet bulb (WB).
Nominal heating capacity rating obtained with air entering the indoor unit at 70°F dry bulb (DB) and 60°F wet bulb (WB) and outdoor ambient conditions of 47°F dry bulb (DB) and 43°F wet bulb (WB).

²This unit comes with a dry helium charge.

³Acceptable operating voltage: 187V-253V.

⁴Sound pressure levels are tested in an anechoic chamber under ISO Standard 3745 and are the same in both cooling and heating mode. These values can increase due to ambient conditions during operation.

⁵All power wiring / communications cable to the IDUs be minimum 18 AWG, 4-conductor, stranded, shielded or unshielded (if shielded, must be grounded to chassis at ODU only) and must comply with applicable local and national codes.

ART COOL GALLERY INDOOR UNITS

MULTI F MAX Cooling Capacity Table

Table 14: Multi F Art Cool Gallery Indoor Units Cooling Capacity Table.

Model No. / Nominal Capacity of Indoor Unit (Btu/h)	Outdoor Air Temp. (°F DB)	Indoor Air Temp. °F DB / °F WB											
		68 / 57		73 / 61		77 / 64		80 / 67		86 / 72		90 / 75	
		TC	SHC	TC	SHC	TC	SHC	TC	SHC	TC	SHC	TC	SHC
LMAN097HVP 9,000	14	8.82	5.68	9.37	6.00	9.92	5.81	10.31	5.93	11.01	5.98	11.56	6.09
	20	8.82	5.72	9.36	6.04	9.91	5.85	10.31	5.98	11.01	6.03	11.55	6.14
	25	8.81	5.77	9.36	6.09	9.90	5.90	10.30	6.02	11.00	6.07	11.54	6.19
	30	8.80	5.81	9.35	6.14	9.90	5.94	10.29	6.07	10.99	6.12	11.54	6.23
	35	8.80	5.85	9.34	6.18	9.89	5.99	10.28	6.11	10.98	6.17	11.53	6.28
	40	8.79	5.90	9.33	6.23	9.88	6.03	10.27	6.16	10.97	6.21	11.52	6.33
	45	8.78	5.94	9.33	6.28	9.87	6.08	10.27	6.21	10.96	6.26	11.51	6.38
	50	8.78	5.99	9.32	6.32	9.87	6.12	10.26	6.25	10.96	6.30	11.50	6.42
	55	8.77	6.03	9.31	6.37	9.86	6.17	10.25	6.30	10.95	6.35	11.49	6.47
	60	8.76	6.07	9.31	6.42	9.85	6.21	10.24	6.34	10.94	6.40	11.48	6.52
	65	8.76	6.12	9.30	6.46	9.84	6.26	10.24	6.39	10.93	6.44	11.47	6.56
	70	8.75	6.16	9.29	6.51	9.84	6.30	10.23	6.43	10.92	6.49	11.47	6.61
	75	8.54	6.06	9.08	6.41	9.62	6.21	10.01	6.35	10.71	6.41	11.25	6.54
	80	8.33	5.96	8.87	6.31	9.41	6.12	9.80	6.26	10.49	6.33	11.03	6.46
	85	8.12	5.85	8.66	6.20	9.20	6.03	9.59	6.17	10.28	6.24	10.82	6.38
	90	7.91	5.74	8.45	6.09	8.99	5.93	9.37	6.07	10.06	6.16	10.60	6.30
	95	7.68	5.68	8.22	6.04	8.75	5.88	9.00	5.94	9.83	6.12	10.36	6.27
	100	7.50	5.52	8.03	5.89	8.57	5.74	8.88	5.85	9.64	5.99	10.17	6.14
105	7.31	5.37	7.84	5.73	8.38	5.60	8.77	5.76	9.45	5.86	9.99	6.01	
110	7.12	5.19	7.66	5.55	8.19	5.43	8.58	5.58	9.26	5.69	9.80	5.85	
115	6.94	5.03	7.47	5.39	8.01	5.29	8.39	5.44	9.08	5.56	9.61	5.71	
118	6.82	5.00	7.36	5.36	7.89	5.26	8.28	5.42	8.96	5.54	9.50	5.70	
122	6.79	4.98	7.32	5.35	7.86	5.25	8.24	5.41	8.93	5.53	9.46	5.69	
LMAN127HVP 12,000	14	10.98	7.06	11.66	7.46	12.34	7.22	12.84	7.38	13.71	7.44	14.39	7.58
	20	10.97	7.12	11.65	7.52	12.33	7.28	12.83	7.43	13.70	7.50	14.38	7.64
	25	10.96	7.17	11.64	7.58	12.32	7.34	12.82	7.49	13.69	7.55	14.37	7.70
	30	10.95	7.23	11.63	7.64	12.31	7.39	12.81	7.55	13.68	7.61	14.36	7.76
	35	10.95	7.28	11.63	7.69	12.31	7.45	12.80	7.61	13.66	7.67	14.34	7.82
	40	10.94	7.34	11.62	7.75	12.30	7.51	12.79	7.66	13.65	7.73	14.33	7.87
	45	10.93	7.39	11.61	7.81	12.29	7.56	12.78	7.72	13.64	7.79	14.32	7.93
	50	10.92	7.45	11.60	7.87	12.28	7.62	12.77	7.78	13.63	7.84	14.31	7.99
	55	10.91	7.50	11.59	7.92	12.27	7.67	12.76	7.83	13.62	7.90	14.30	8.05
	60	10.90	7.56	11.58	7.98	12.26	7.73	12.75	7.89	13.61	7.96	14.29	8.11
	65	10.90	7.61	11.57	8.04	12.25	7.78	12.74	7.95	13.60	8.02	14.28	8.17
	70	10.89	7.67	11.56	8.10	12.24	7.84	12.73	8.01	13.59	8.07	14.27	8.23
	75	10.63	7.54	11.30	7.97	11.97	7.73	12.46	7.90	13.32	7.97	14.00	8.13
	80	10.36	7.41	11.04	7.85	11.71	7.62	12.19	7.79	13.05	7.87	13.73	8.04
	85	10.10	7.27	10.77	7.72	11.45	7.50	11.93	7.67	12.79	7.77	13.46	7.94
	90	9.84	7.14	10.51	7.58	11.18	7.38	11.67	7.56	12.52	7.66	13.19	7.83
	95	9.56	7.06	10.23	7.51	10.89	7.32	11.20	7.39	12.23	7.62	12.89	7.80
	100	9.33	6.87	10.00	7.32	10.66	7.15	11.05	7.28	11.99	7.45	12.66	7.64
105	9.10	6.68	9.76	7.13	10.43	6.97	10.91	7.16	11.76	7.29	12.43	7.48	
110	8.86	6.46	9.53	6.90	10.20	6.76	10.68	6.95	11.53	7.08	12.19	7.27	
115	8.63	6.26	9.30	6.71	9.96	6.58	10.44	6.77	11.30	6.91	11.96	7.11	
118	8.49	6.22	9.16	6.67	9.82	6.54	10.30	6.74	11.16	6.89	11.82	7.09	
122	8.44	6.20	9.11	6.65	9.78	6.53	10.26	6.73	11.11	6.88	11.78	7.08	

TC = Total Capacity (kBtu/h).

SHC: Sensible Heat Capacity (kBtu/h).

Nominal capacity as rated 0 ft. above sea level and a 0 ft. level difference between outdoor and indoor units. Corresponding refrigerant piping length is accordance with standard length of each outdoor unit.

Nominal cooling capacity rating obtained with air entering the indoor unit at 80°F dry bulb (DB) and 67°F wet bulb (WB), and outdoor ambient conditions of 95°F dry bulb (DB) and 75°F wet bulb (WB).

The shaded table columns and rows indicate reference data. When operating at this temperature, these values can be different if the system is not running consistently.

Table 15: Multi F Art Cool Gallery Indoor Units Heating Capacity Table.

Model No. / Nominal Capacity of Indoor Unit (Btu/h)	Outdoor Air Temp.		Indoor Air Temp. °F DB					
	°F DB	°F WB	61	64	68	70	72	75
			TC	TC	TC	TC	TC	TC
LMAN097HVP 9,000	0	-0.4	5.35	5.28	5.23	5.20	5.12	4.90
	5	4.5	6.03	5.95	5.90	5.88	5.80	5.58
	10	9	6.71	6.63	6.58	6.56	6.48	6.26
	17	15	7.61	7.54	7.49	7.46	7.39	7.14
	20	19	7.95	7.88	7.83	7.80	7.72	7.46
	25	23	8.52	8.44	8.39	8.37	8.29	7.99
	30	28	9.01	8.93	8.88	8.86	8.78	8.52
	35	32	9.50	9.42	9.37	9.34	9.27	9.04
	40	36	9.94	9.86	9.81	9.78	9.71	9.48
	45	41	10.37	10.30	10.25	10.22	10.15	9.92
	47	43	10.55	10.48	10.43	10.40	10.32	10.10
	50	46	10.72	10.64	10.59	10.57	10.49	10.24
	55	51	11.00	10.93	10.88	10.85	10.78	10.48
	60	56	11.00	10.93	10.88	10.85	10.78	10.52
	63	59	11.00	10.93	10.88	10.85	10.78	10.55
68	64	11.00	10.93	10.88	10.85	10.78	10.60	
LMAN127HVP 12,000	0	-0.4	6.84	6.75	6.68	6.65	6.55	6.26
	5	4.5	7.71	7.61	7.55	7.52	7.42	7.13
	10	9	8.58	8.48	8.42	8.38	8.29	8.00
	17	15	9.73	9.64	9.57	9.54	9.44	9.14
	20	19	10.17	10.07	10.01	9.98	9.88	9.54
	25	23	10.89	10.79	10.73	10.70	10.60	10.22
	30	28	11.52	11.42	11.36	11.32	11.23	10.89
	35	32	12.14	12.05	11.98	11.95	11.85	11.57
	40	36	12.71	12.61	12.55	12.51	12.42	12.13
	45	41	13.27	13.17	13.11	13.08	12.98	12.69
	47	43	13.49	13.40	13.33	13.30	13.20	12.91
	50	46	13.71	13.61	13.55	13.52	13.42	13.10
	55	51	14.07	13.97	13.91	13.88	13.78	13.40
	60	56	14.07	13.97	13.91	13.88	13.78	13.46
	63	59	14.07	13.97	13.91	13.88	13.78	13.49
68	64	14.07	13.97	13.91	13.88	13.78	13.55	

TC = Total Capacity (kBtu/h).

Nominal capacity as rated 0 ft. above sea level and a 0 ft. level difference between outdoor and indoor units. Corresponding refrigerant piping length is accordance with standard length of each outdoor unit. Nominal heating capacity rating obtained with air entering the indoor unit at 70°F dry bulb (DB) and 60°F wet bulb (WB), and outdoor ambient conditions of 47°F dry bulb (DB) and 43°F wet bulb (WB).

ART COOL GALLERY INDOOR MULTI F MULTI F MAX

Acoustic Data

Figure 32: Sound Pressure Level Measurement Location.

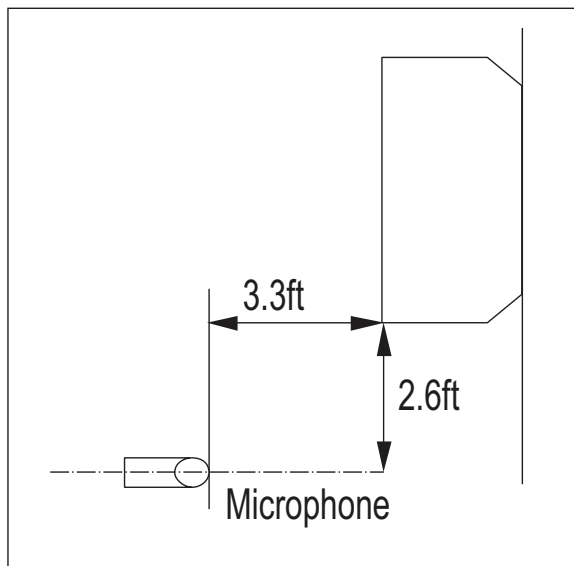

- Measurement taken 2.6' below the bottom of the unit and at a distance of 3.3' from face of unit.
- Measurements taken with no attenuation and units operating at full load normal operating condition.
- Sound level will vary depending on a range of factors such as construction (acoustic absorption coefficient) of particular area in which the equipment is installed.
- Sound power levels are measured in dB(A)±3.
- Tested in anechoic chamber per ISO Standard 3745.

Table 16: Sound Pressure Levels (dB[A]).

Model No.	Sound Pressure Levels (dB[A]) (Cooling and Heating)		
	High Fan Speed	Medium Fan Speed	Low Fan Speed
LMAN097HVP	39	35	31
LMAN127HVP	42	38	34

Figure 33: Sound Pressure Level Diagrams.

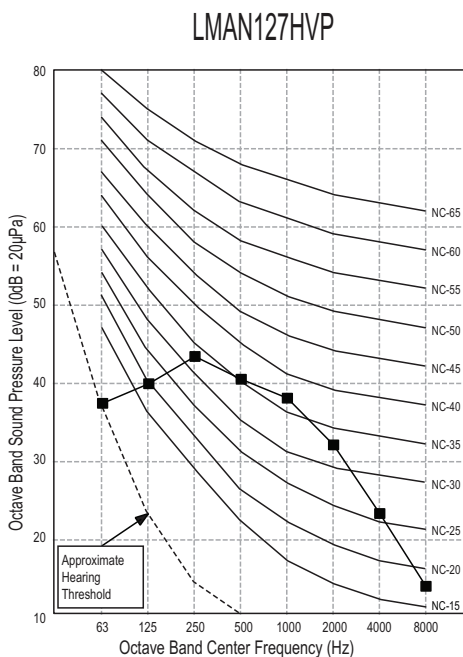
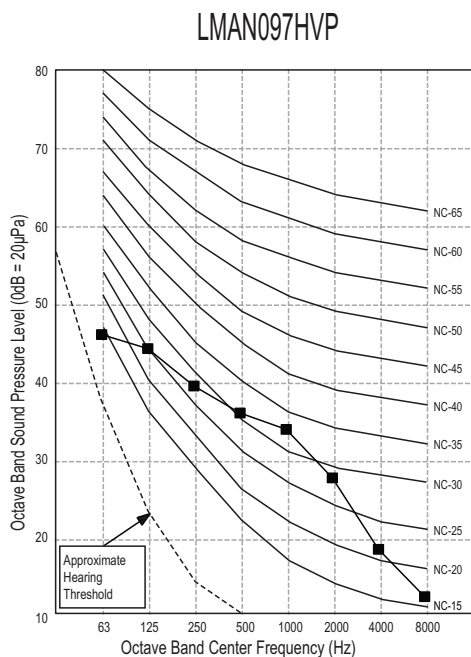

Figure 34: LMAN097HVP Air Velocity and Temperature Distribution Charts.

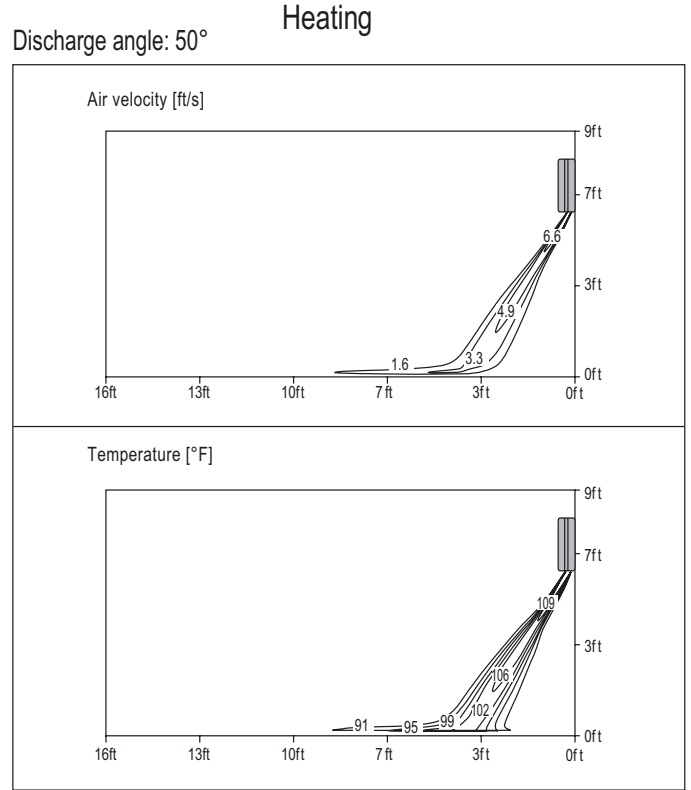
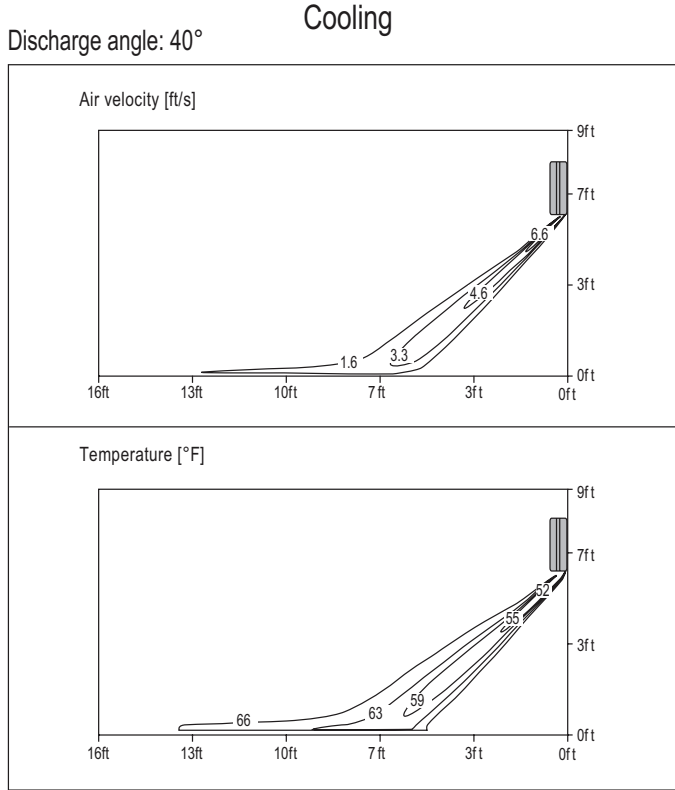
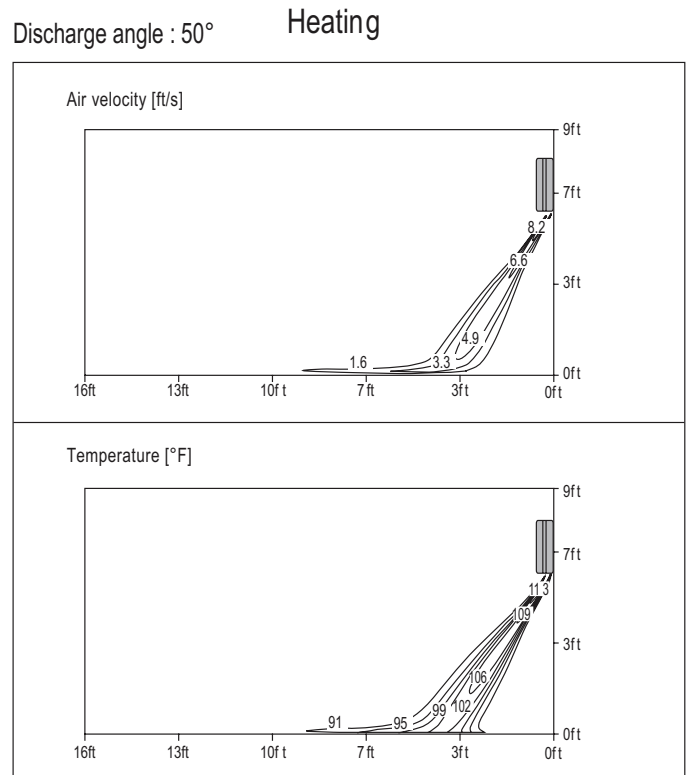
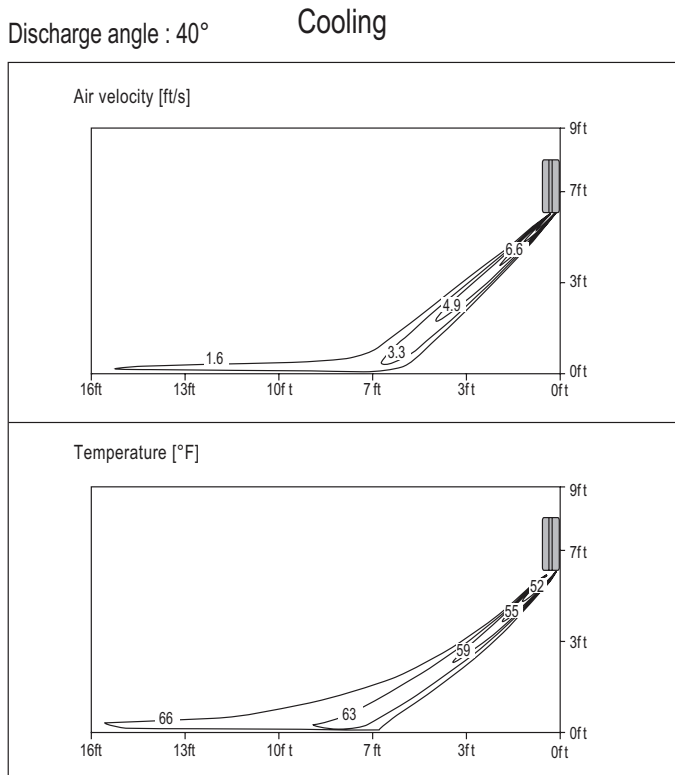

Figure 35: LMAN127HVP Air Velocity and Temperature Distribution Charts.



ART COOL GALLERY INDOOR UNITS

Refrigerant Flow Diagram

Figure 36: Art Cool Gallery Indoor Unit Refrigerant Flow Diagram.

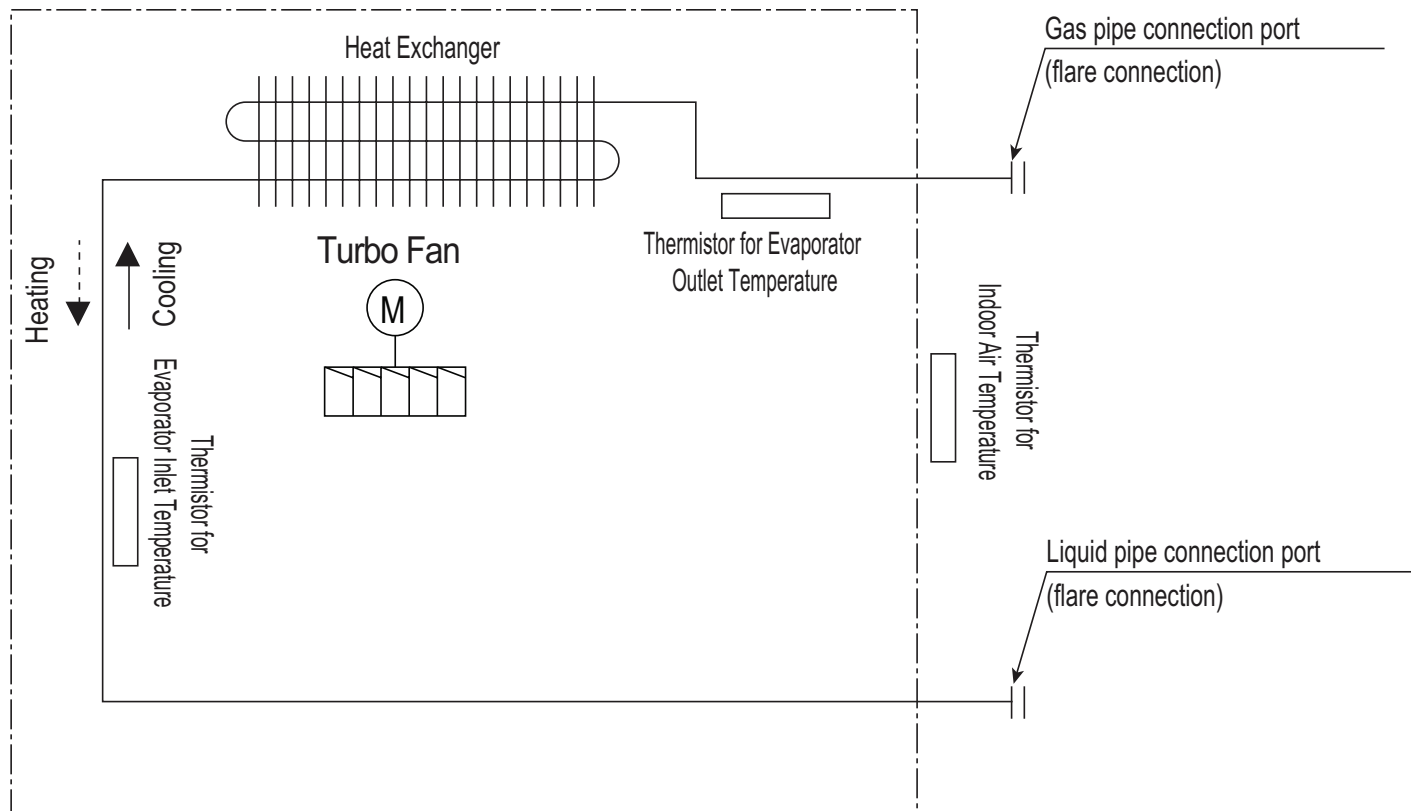

Table 17: Art Cool Gallery Indoor Unit Refrigerant Pipe Connection Port Diameters.

Model No.	Vapor (inch)	Liquid (inch)
LMAN097HVP	Ø3/8	Ø1/4
LMAN127HVP		

Table 18: Art Cool Gallery Indoor Unit Thermistor Details.

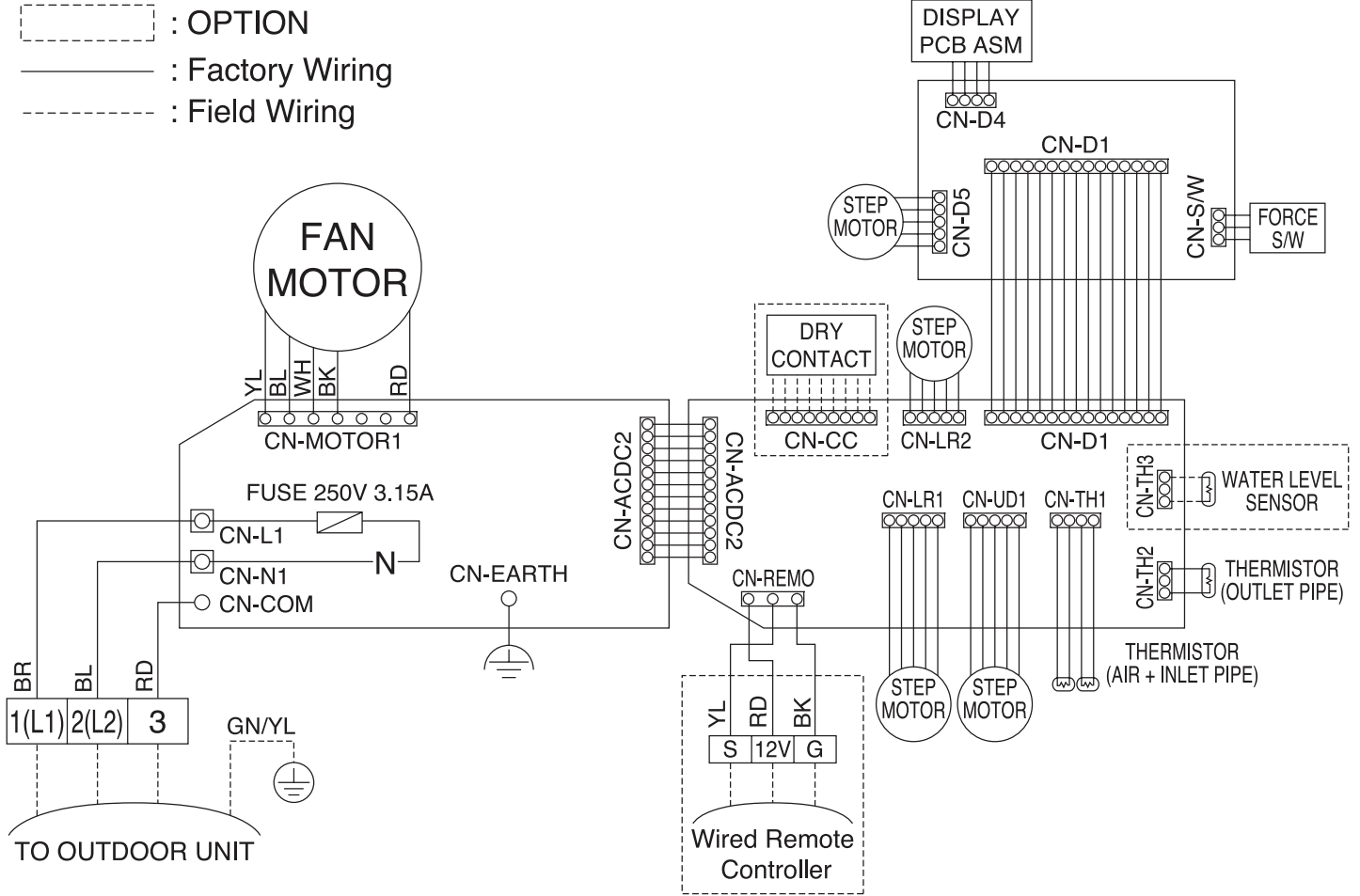

Description (Based on Cooling Mode)	PCB Connector
Indoor Air Temperature Thermistor	CN-TH1
Evaporator Inlet Temperature Thermistor	
Evaporator Outlet Temperature Thermistor	CN-TH2
Water Level Sensor (Optional)	CN-TH3

Figure 37: Multi F Art Cool Gallery Indoor Units Wiring Diagram.

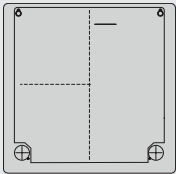
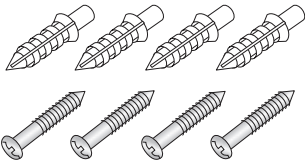
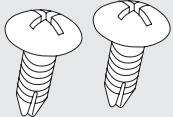

Factory Supplied Parts

Table 19: Parts Table.

Part	Quantity	Image
Installation Guide	One (1)	
Type "A" Screws and Plastic Anchors	Four (4) Each	
Type "B" Screws (M4 x 12L)	Two (2)	
Wireless Handheld Controller with Holder (AKB73635607)	One (1)	

Factory Supplied Materials

- Owner's Manual
- Installation Manual

Required Tools

- Level
- Screwdriver
- Electric drill
- Hole core drill
- Flaring tool set
- Spanner (Half union)
- Thermometer

⚠ WARNING

Installation work must be performed by trained personnel and in accordance with national wiring standards and all local or other applicable codes. Improper installation can result in fire, electric shock, physical injury, or death.

Note:

Read all instructions before installing this product. Become familiar with the unit's components and connections, and the order of installation. Incorrect installation can degrade or prevent proper operation.

Selecting the Best Location

Do's

- Place the unit where air circulation will not be blocked.
- Place the unit where drainage can be obtained easily.
- Place the unit where noise prevention is taken into consideration.
- Ensure there is sufficient space from the ceiling and floor.
- Ensure there is sufficient maintenance space.
- Locate the indoor unit in a location where it can be easily connected to the outdoor unit/branch distribution unit.

Don'ts

- Do not install the unit near a heat or steam source, or where considerable amounts of oil, iron powder, or flour are used.
- Do not install the unit where sulfuric acid and flammable or corrosive gases are generated, vented into, or stored.
- Do not install the unit near high-frequency generators.
- Do not install the unit near a doorway.

The unit may be damaged, may malfunction, and/or will not operate as designed if installed in any of the conditions listed.

Installing in an Area Exposed to Unconditioned Air

In some installation applications, areas (floors, walls) in some rooms may be exposed to unconditioned air (room may be above or next to an unheated garage or storeroom). To countermeasure:

- Verify that carpet is or will be installed (carpet may increase the temperature by three degrees).
- Add insulation between the floor joists.
- Install radiant heat or another type of heating system to the floor.

Using the Installation Guide

1. Choose an appropriate location for the indoor unit. To hang the installation guide, verify that it is level and plumb, and then tape it to the wall.
2. Drill four (4) 1/4-inch diameter holes with a depth of 1-3/16 to 1-3/8 inches for the mounting screws. Drill one (1) two (2) inch-diameter hole for the field-installed refrigerant and drain piping.
3. Insert a plastic anchor into each of the mounting holes.
4. Screw the top two (2) screws into the wall. Do not flush them to the wall; leave a 7/16 inch space for hanging the indoor unit.

Note:

If the unit is installed near a body of water, certain components are at risk of being corroded. Appropriate anti-corrosion methods should be taken for the unit and all components.

Figure 38: Minimum Clearance Requirements.

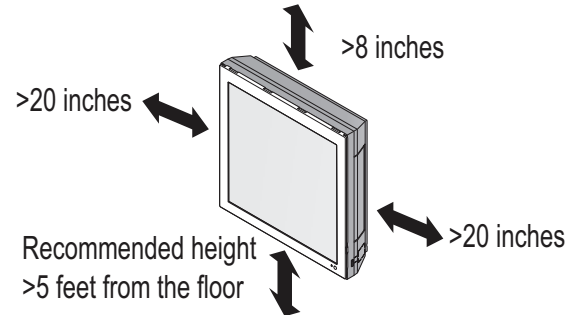
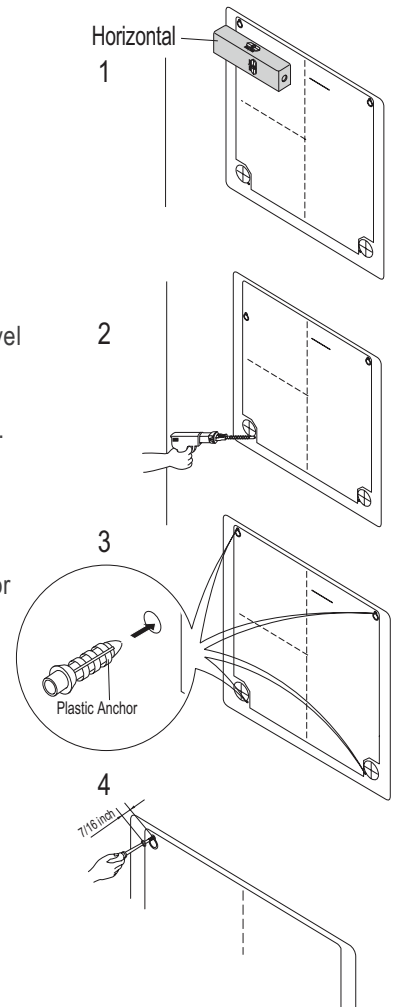

Figure 39: Using the Installation Guide.



ART COOL GALLERY INDOOR MULTI F MAX

Installation and Best Layout Practices

Preparing the Indoor Unit for Installation

Removing the Front Panel

1. First pull the top of the front panel up (1A) and then out (1B).
2. Remove the two (2) screws at the bottom (2A), then lift off the front panel (2B).
3. To completely detach the front panel, disconnect the panel connector found at the top of the indoor unit (3).

Figure 40: Preparing for Installation.

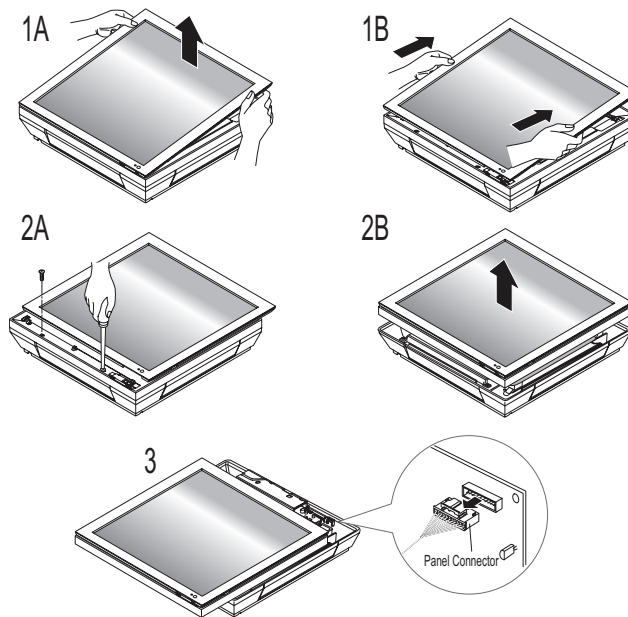

Removing the Piping and Side Covers

1. Unscrew the center cover.
2. Remove the cover from the side of the indoor unit chosen for the piping connections, and then knock out the piping access hole. If the refrigerant piping will be connected through the back of the unit, the access hole does not need to be knocked out.
3. Remove any burrs that may have been made.

Figure 41: Removing the Piping and Side Covers.

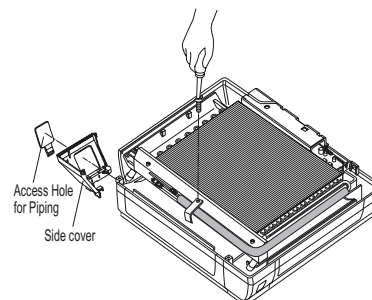

Preparing the Drain Hose

1. Remove the rubber stopper from the chosen side of the indoor unit.
2. Insert the drain hose into the handle of the drain pan.
3. Connect the drain hose to the field-installed drain piping.

Figure 42: Preparing the Drain Hose.

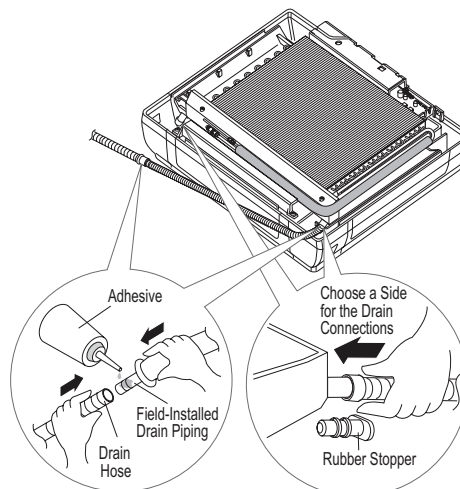

Preparing the Refrigerant and Drain Piping Connections

1. Depending on the installation requirements, route the indoor unit refrigerant piping and the drain hose to the left, right (see guidelines below), or rear of the frame.
2. Bundle the piping and drain hose with tape where they meet near the indoor unit frame. Position the drain hose at the bottom of the bundle (positioning the drain hose at the top of the bundle may cause the drain pan to overflow inside the indoor unit).

Figure 43: Preparing the Refrigerant / Drain Connections.

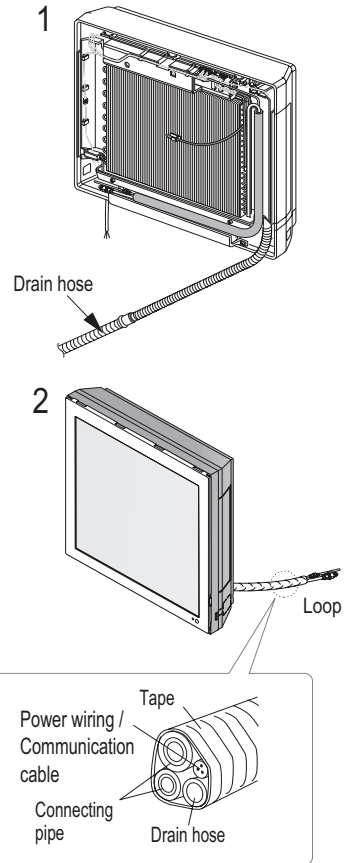

Installing Piping on the Right Side of the Indoor Unit Frame

1. Press on the top of the clamp, and then slowly guide the piping downward.
2. Bend the piping to the right side of the indoor unit frame.

Figure 44: Right Side Piping Access.

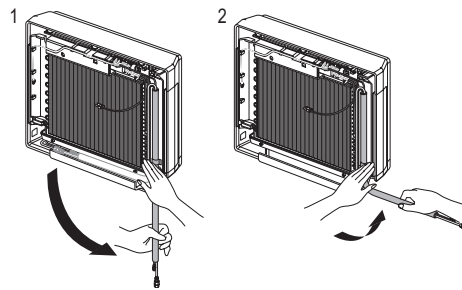

Note:

Do not bend the piping/drain hose from side to side; it may damage the components.

Hanging the Indoor Unit Frame

1. Remove the installation guide and hang the indoor unit on the top two (2) screws. Verify the indoor unit is hanging securely on the screws.
2. Align the holes at the bottom of the indoor unit to the mounting holes. Tighten first the top screws, then tighten the bottom screws.
3. Verify that the indoor unit is completely secured to the wall by gently shaking it up and down.

Figure 45: Hanging the Indoor Unit Frame.

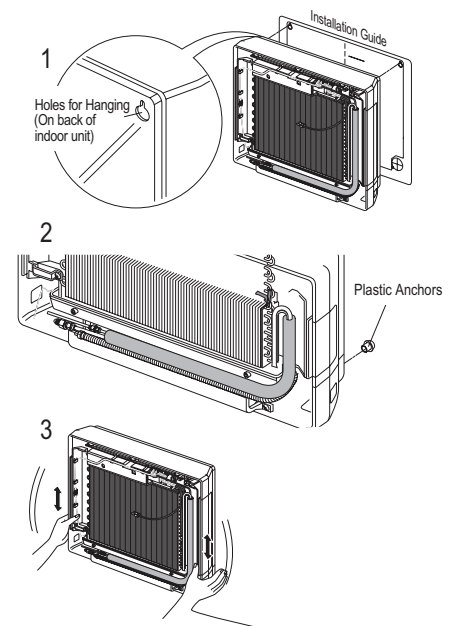

Connecting the Indoor Unit Piping to the Field-Installed Piping

1. Center align the indoor unit piping (refrigerant and drain) and the field-installed piping, then hand tighten the flare nut.
2. Tighten the flare nut with a torque wrench.
3. Attach the drain tube piping to the indoor unit drain hose as shown below.

Figure 46: Indoor Unit to Field-Installed Piping Connection.

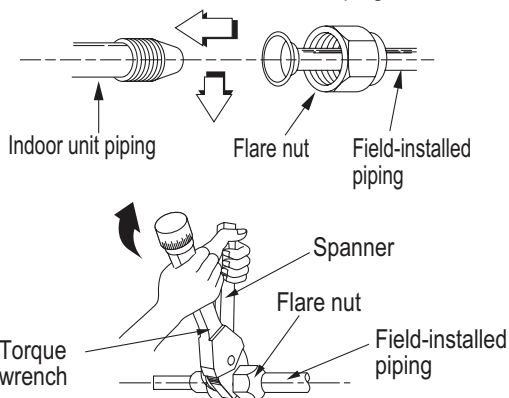
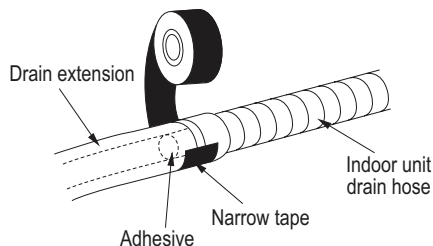

Figure 47: Extending the Drain Hose.



Note:

If the drain hose is routed inside a room, add insulation to prevent condensation from forming.

Insulating the Refrigerant and Drain Piping

⚠ WARNING

Ensure all piping is insulated. Exposed piping can cause burns if touched.

Refrigerant Piping Insulation

Field-installed vapor and liquid refrigerant piping lines must be properly and completely covered in insulation (up to the indoor unit piping connections). Any exposed piping may generate condensate or will cause burns if touched. Insulation for this field-installed refrigerant piping must have a minimum heat resistance of 248°F.

Drain Piping Insulation

Drain piping must have insulation a minimum of 7/32 inches thick.

Installing the Insulation

1. Overlap the insulation at the connection of the field-installed piping and the indoor unit piping. Tape together so there are no gaps.
2. Secure insulation to the rear piping housing section with vinyl tape.
3. Bundle the piping and drain hose with tape where they meet at the back of the indoor unit frame. Position the drain hose at the bottom of the bundle (positioning the drain hose at the top of the bundle may cause the drain pan to overflow inside the indoor unit).

Figure 48: Insulating the Piping.

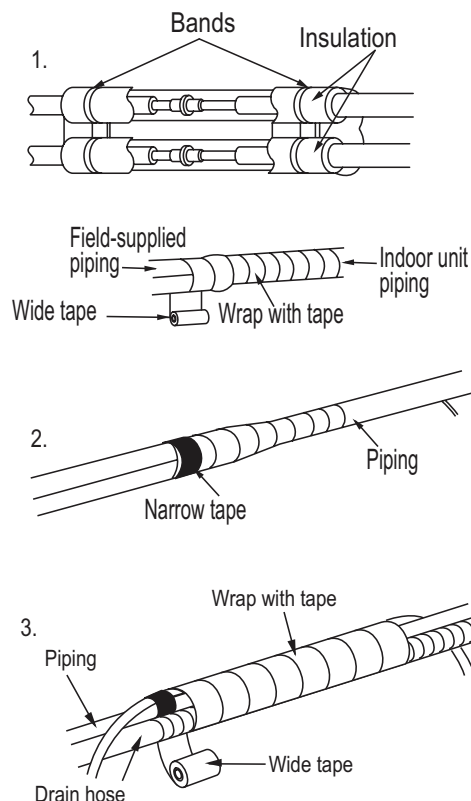

Drain Slope

Drain hose should point down so water can flow away easily.

Figure 49: Drain Piping Slope.

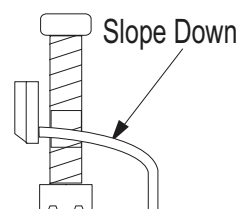

Checking the Drainage System

1. Pour water on the indoor unit evaporator.
2. Ensure the water flows through and out of the hose and away from the indoor unit without leaking.

Figure 50: Checking the Drainage System.

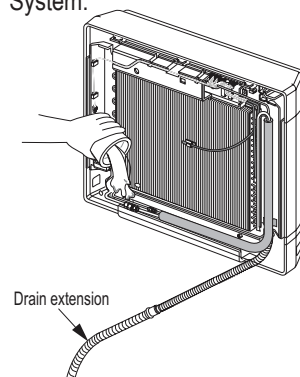

Power Wiring / Communications Cable Guidelines

- Follow manufacturer’s circuit diagrams in the technical manuals.
- Confirm power source specifications.
- Confirm that the electrical capacity is sufficient.
- Starting current must be maintained ± 10 percent of the rated current marked on the outdoor unit name plate.
- Confirm cable thickness specifications.
- It is recommended that a circuit breaker is installed, especially if conditions could become wet or moist.
- Include a disconnect in the power wiring system, add an air gap contact separation of at least 1/8 inch in each active (phase) conductor.

⚠ WARNING

- Loose wiring may cause unit to malfunction, overheat, and catch fire, resulting in severe injury or death.

Note:

- Terminal screws may become loose during transport. Properly tighten the terminal connections during installation.
- A voltage drop may cause the following problems:
- Magnetic switch vibration, fuse breaks, or disturbance to the normal function of an overload protection device.
 - Compressor will not receive the proper starting current.

Connecting the Power Wiring and Communications Cable

1. Insert the power wiring/communications cable from the outdoor unit or branch distribution unit (Multi F MAX systems only) through the access hole of the indoor unit (ground wire should be longer than the other wires/cables). Unscrew the control board cover.
2. Connect each wire to its appropriate terminal on the indoor unit control board. Verify that the color and terminal numbers from the outdoor unit or branch distribution unit (Multi F MAX systems only) wiring match the color and terminal numbers on the indoor unit.
3. Secure the power wiring/communications cable to the control board.
4. Reattach the control board cover.

Figure 51: Connecting the Power Wiring / Communications Cable.

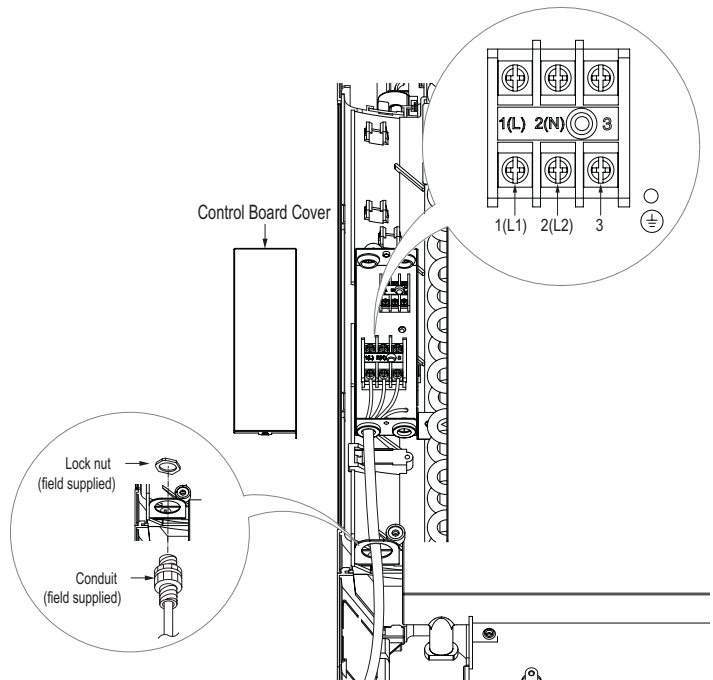
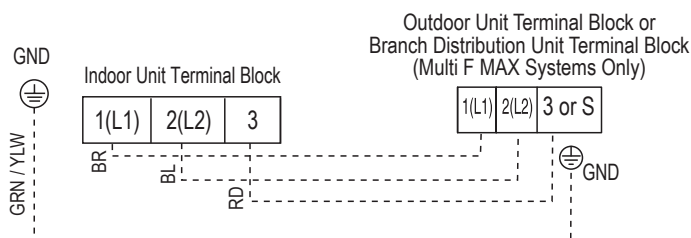

Figure 52: Simplified View of Indoor Unit to Outdoor Unit / Branch Distribution Unit Terminal Connections—LMAN097HVP and LMAN127HVP models.



ART COOL GALLERY INDOOR UNITS

Installation and Best Layout Practices

Controller Options

Art Cool Gallery wall-mounted indoor units include a handheld controller (AKB73635607), but optional LG-supplied wired controllers are available.

Wireless Handheld Controller

Figure 53:AKB73635607 Wireless Controller.



Table 20: AKB73635607 Wireless Controller Functions.

Control Panel Button	Display Screen	Description
FAN		Air circulation button ¹ : Circulates the room air without operating in cooling or heating mode.
SLEEP		Sleep Mode Auto Button ¹ : Sets the sleep mode auto operation.
TEMP (up/down arrows)		Temperature Adjustment Buttons: Raises or lowers temperature setpoint in cooling and heating operation.
ON/OFF	-	On / Off Button: Turns the power on/off.
FAN SPEED		Indoor Fan Speed Button: Changes the fan speed.
MODE		Operation mode selection button ¹ : Selects the operation mode. Cooling operation / Auto operation or auto changeover / Dehumidifying operation / Heating operation
JET		Jet Cool / Jet Heat Button ¹ : Warms up or cools down the indoor temperature within a short period.
SWING		Air Flow Direction Button: Adjusts the airflow direction.
ROOM TEMP		Temperature Display Button: Displays the room temperature. Press and hold button down for five (5) seconds to change from °C to °F.
ON/OFF		Timer button: Sets the current time and the start/end times.
A/CLEAN, E/SAVING, LIGHT		Navigation/Functions Button ¹ : Adjusts the time and sets the special functions. Auto clean / Operates energy saving cooling / Adjusts the brightness of the indoor unit display
SET CLEAR	-	Set/Clear Button: Sets or cancels functions.
○	-	Reset Button: Resets the air conditioner settings.

Operation Mode Sequence

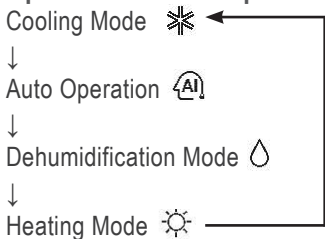

¹Depending on the indoor unit model, some functions may not be supported.

Wired Controller Connections

Figure 54: Wired Controller Connection on the Indoor Unit Terminal Block.

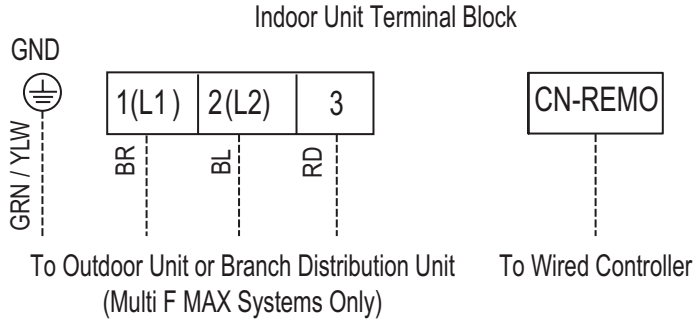

Wired Controller Placement

Wired controllers include a sensor to detect room temperature. To maintain comfort levels in the conditioned space, the wired controller must be installed in a location away from direct sunlight, high humidity, and where it could be directly exposed to cold air. Controller must be installed four (4) to five (5) feet above the floor where its LED display can be read easily, in an area with good air circulation, and where it can detect an average room temperature.

- ⊘ Do not install the wired controller near or in:
 - Drafts or dead spots behind doors and in corners
 - Hot or cold air from ducts
 - Radiant heat from the sun or appliances
 - Concealed pipes and chimneys
 - An area where temperatures are uncontrolled, such as an outside wall

Hanging the Wired Controller

1. The controller wiring/cable can be installed in one of three directions: top, back, or on the right side. If top or right side installation is desired, remove cable guide grooves on the controller, and then position wiring/cable on applicable side.
2. Choose and mark the area of installation, and then screw the wall plate into place (using the provided parts). Install the controller wall plate to fit the electrical box if one is present. Ensure that no gaps exist between the wall plate and the wall itself.
3. Arrange wiring/cables so as not to interfere with the controller circuitry. Position the wired controller on the wall plate. Snap into place by pressing the bottom part of the wired controller onto the wall plate. Make sure that no gaps exist between the wired controller and the wall plate on all sides.
4. To remove wired controller from the wall plate, insert a screwdriver into the two holes at the bottom. Twist screwdriver to release controller. Do not damage the controller components when removing.

Figure 55: Proper Location for the Wired Controller.

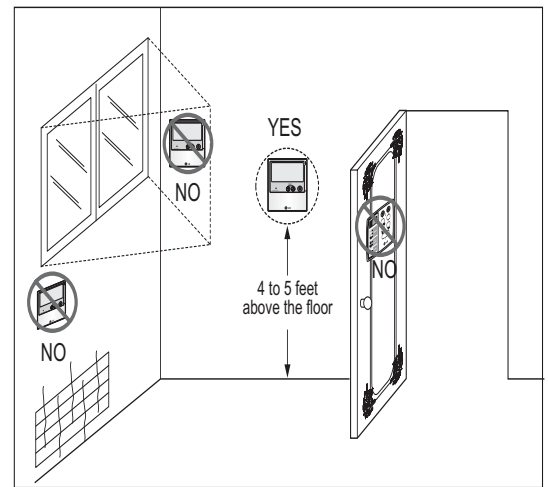

Figure 56: Removing the Cable Guide Grooves.

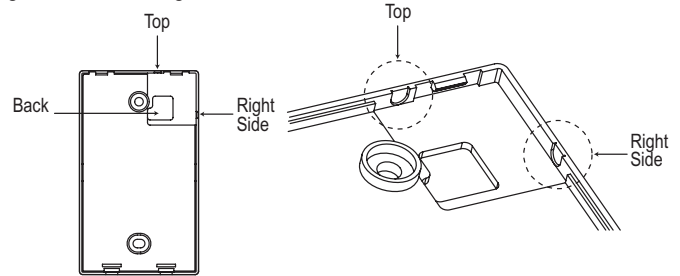

Figure 57: Attaching the Wall Plate.

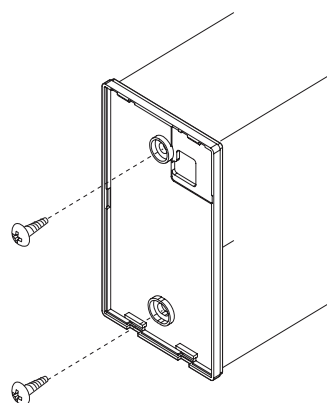
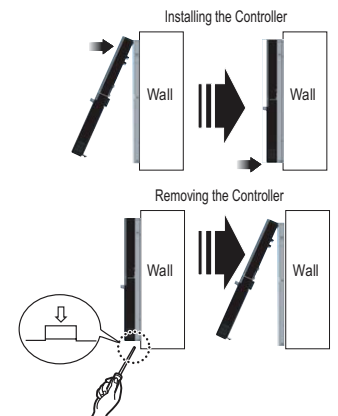

Figure 58: Installing/Removing the Controller.



Assigning the Thermistor for Temperature Detection

Each indoor unit includes a return air thermistor assigned to sense the temperature. If a wired controller is installed, there is a choice of sensing temperature with either the indoor unit return air thermistor or the thermistor in the wired controller. It is also an option to set both thermistors to sense temperature so that indoor unit bases its operation on the first thermistor to reach the designated temperature differential. For applicable indoor units, an optional Remote Temperature Sensor can be used in lieu of the return air thermistor—either alone or in conjunction with a wired controller thermistor as previously described.

Finalizing Indoor Unit Installation

1. Verify that the side covers are closed or opened, depending on installation requirements. Place the power wiring / communications cable in the bottom groove along the left side of the frame.
2. Reconnect the panel connector found at the top of the indoor unit.
3. Attach the top part of the front panel, then position its tabs in the grooves on the bottom part of the indoor unit frame.
4. To ensure the front panel tabs are securely positioned in the grooves, adjust the panel by loosening or tightening the screws at the bottom.

Figure 59: Final Installation Step—Reattaching the Front Panel.

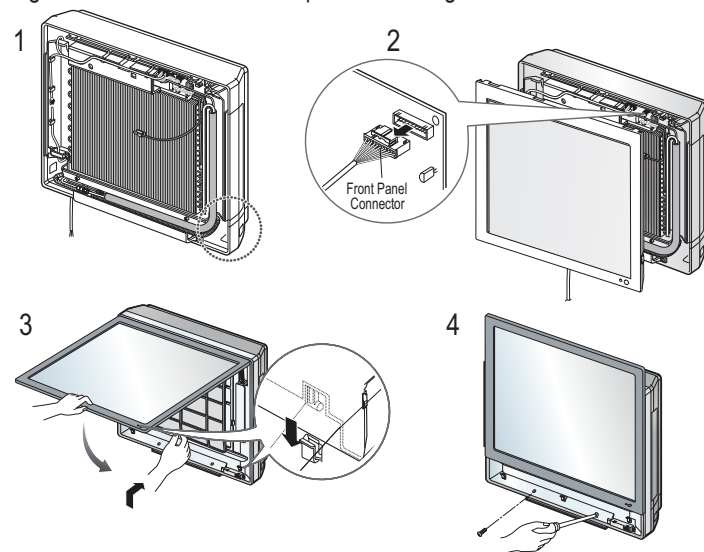

MULTI F
MULTI F MAX

Art Cool Gallery™



STANDARD WALL-MOUNTED INDOOR UNIT DATA

- “Mechanical Specifications” on page 49**
- “General Data / Specifications” on page 50**
- “Dimensions” on page 51**
- “Cooling Capacity Table” on page 53**
- “Heating Capacity Table” on page 56**
- “Acoustic Data” on page 58**
- “Air Velocity and Temperature Distribution” on page 60**
- “Refrigerant Flow Diagram” on page 62**
- “Wiring Diagram” on page 63**
- “Factory Supplied Parts and Materials” on page 65**
- “Installation and Best Layout Practices” on page 66**

Standard Wall-Mounted Indoor Units

General

All LG indoor units are factory assembled, wired, piped, and provided with a control circuit board, fan, and motor. Standard Wall-Mounted units have a sound rating no higher than 46 dB(A) as tested per KSA0701 ISO Standard 3745.

Coil

Indoor unit coils are comprised of a minimum of two rows of aluminum fins mechanically bonded to copper tubing. The coils are pressure tested at the factory. Each unit is provided with a factory installed condensate drain pan below the coil.

Refrigerant System

The system is designed for use with R410A refrigerant. The refrigeration circuit is pressure-tested at the factory and shipped with a holding charge of helium gas. Refrigerant pipe connections are 45° flare. All refrigerant lines from the outdoor unit to the indoor units must be field insulated.

Electrical

The indoor units require 208–230Vac/60Hz/1Φ power with voltage variance of no more than ±10%.

Casing

The units mount on a vertical surface. They are shipped with a separate back plate that secures the unit to the wall, protruding no more than nine (9) inches. Refrigerant piping can be installed in one (1) of four (4) different directions.

Finish

The Standard Wall-Mounted unit has a curved architectural panel with a pearl white finish. Unit casing has a pearl white or dark gray finish and is manufactured of heavy-duty acrylonitrile butadiene styrene (ABS) and high impact polystyrene (HIPS) plastic.

Fan Assembly and Control

The unit has a single, direct-drive, crossflow fan made of high strength ABS plastic. The fan motor is brushless digitally controlled (BLDC) with permanently lubricated and sealed ball bearings. The fan / motor assembly is mounted on vibration attenuating rubber grommets. Fan speed is controlled using a microprocessor-based direct digitally controlled algorithm that provides pre-programmed, field-selectable fixed or auto fan speeds in the Heating and Cooling modes. For Standard Wall-Mounted units, the indoor fan has Low, Med, High, Jet Cool, and Auto settings for Cooling mode; and has Low, Med, High, Jet Heat, and Auto settings for Heating mode. The Auto setting adjusts the fan speed based on the difference between the controller setpoint and space temperature. Also, the separate Chaos setting provides a simultaneous and random change in fan speed and flow direction at the discharge, simulating a natural outdoor breeze.

Features

- Inverter (Variable speed fan)
- Comfort Air
- 3M filter
- Jet cool/Jet Heat
- Group control
- Self-cleaning indoor coil
- Auto operation
- Auto restart operation
- Built-in wi-fi
- Dehumidifying function
- Self-diagnostic function
- Wireless LCD remote control included

Figure 60: Multi F Standard Wall-Mounted Indoor Unit.

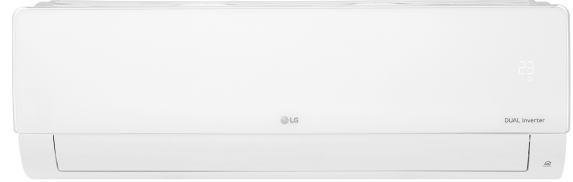

Air Filter

The return air inlet has a factory-supplied primary removable, washable filter. The unit is also equipped with a secondary 3M Micro Dust filter. Filters are accessed from the front of the unit without the use of tools.

Airflow Guide Vanes

A factory-installed motorized guide vane controls the direction of airflow from side to side. A motorized louver provides an automatic change in airflow by directing the air up and down for uniform air distribution.

Microprocessor Control

The indoor unit has an integrated control panel to communicate with the outdoor unit. All unit operation parameters are stored in non-volatile memory resident on the unit microprocessor. The microprocessor controls space temperature through using the value provided by the temperature sensor within the indoor unit. The microprocessor control will activate indoor unit operation when the indoor room temperature falls below or rises above a setpoint temperature, at which point, a signal is sent to the outdoor unit to begin the appropriate mode. The microprocessor also provides self-diagnostics and auto restart functions. A field-supplied four-wire power / communications cable must be installed to connect the indoor unit(s) to the outdoor unit.

Controls

The indoor unit casing has a factory-standard, integral infrared sensor to communicate with the supplied LG wireless handheld remote controller. An optional LG supplied wired controller is available as an additional accessory. Communication between the indoor units and the outdoor unit is accomplished through 18 AWG, four-core, stranded and shielded power / communication cable. The indoor unit has built-in wi-fi and can be controlled with LG's SmartThinQ app on a smart device. A field-supplied wi-fi network and smart device are required. The SmartThinQ app is free and is available for Android and iOS smart devices.

Condensate

The unit is designed for gravity draining of condensate and includes a flexible drain hose capable of installation in one of two directions. The unit also includes a connection that is compatible with the AquaGuard® AG-9300-LG condensate sensor.

STANDARD WALL-MOUNTED INDOOR UNITS

General Data / Specifications

MULTI F
MULTI F MAX

Table 21: Multi F Standard Wall-Mounted Indoor Unit General Data.

Model Name	LMN079HVT	LSN090HSV5	LSN120HSV5	LMN159HVT	LSN180HSV5	LMN249HVT
Nominal Cooling Capacity (Btu/h) ¹	7,000	9,000	12,000	14,300	18,000	24,000
Nominal Heating Capacity (Btu/h) ¹	8,100	10,900	13,600	15,600	21,600	25,600
Operating Range						
Cooling (°F WB)	57-77					
Heating (°F DB)	59-81					
Fan						
Type	Cross Flow					
Motor Output (W) x Qty.	30 x 1			60 x 1		
Motor/Drive	Brushless Digitally Controlled / Direct					
Airflow Rate CFM (H/M/L)	254 / 204 / 148	268 / 218 / 169	282 / 233 / 177	314 / 268 / 184	558 / 438 / 353	597 / 452 / 367
Unit Data						
Refrigerant Type ²	R410A					
Refrigerant Control	EEV					
Power Supply V, Ø, Hz ³	208-230, 1, 60					
Rated Amps (A)	0.4					
Sound Pressure Level ±3 dB(A) (H/M/L) ⁴	35 / 31 / 26	36 / 32 / 27	38 / 34 / 29	42 / 38 / 32	44 / 38 / 34	46 / 41 / 36
Dimensions (W x H x D, in.)	32-15/16 x 12-1/8 x 7-7/16			39-9/32 x 13-19/32 x 8-9/32		
Net Unit Weight (lbs.)	18.3			25.6		
Shipping Weight (lbs.)	23.4			32.2		
Power Wiring / Communications Cable (No. x AWG) ⁵	4 x 18					
Heat Exchanger (Row x Column x Fin / inch) x Number	(2 x 23 x 22) x 1			(2 x 16 x 20) x 1		
Pipe Size						
Liquid (in.)	1/4					
Vapor (in.)	3/8			1/2		
Connection Size						
Liquid (in.)	1/4			3/8		1/4
Vapor (in.)	3/8			5/8		1/2
Drain O.D. / I.D. (in.)	27/32, 5/8					

¹Nominal capacity is rated 0 ft. above sea level with corresponding refrigerant piping length in accordance with standard length of each outdoor unit and a 0 ft. level difference between outdoor and indoor units. All capacities are net with a combination ratio between 95 – 105%.

Nominal cooling capacity rating obtained with air entering the indoor unit at 80°F dry bulb (DB) and 67°F wet bulb (WB) and outdoor ambient conditions of 95°F dry bulb (DB) and 75°F wet bulb (WB).
Nominal heating capacity rating obtained with air entering the indoor unit at 70°F dry bulb (DB) and 60°F wet bulb (WB) and outdoor ambient conditions of 47°F dry bulb (DB) and 43°F wet bulb (WB).

²This unit comes with a dry helium charge.

³Acceptable operating voltage: 187V-253V.

⁴Sound pressure levels are tested in an anechoic chamber under ISO Standard 3745 and are the same in both cooling and heating mode. These values can increase due to ambient conditions during operation.

⁵All power wiring / communications cable to the IDUs be minimum 18 AWG, 4-conductor, stranded, shielded or unshielded (if shielded, must be grounded to chassis at ODU only) and must comply with applicable local and national codes.

Figure 61: LMN079HVT, LSN090HSV5, LSN120HSV5, and LMN159HVT Dimensions.

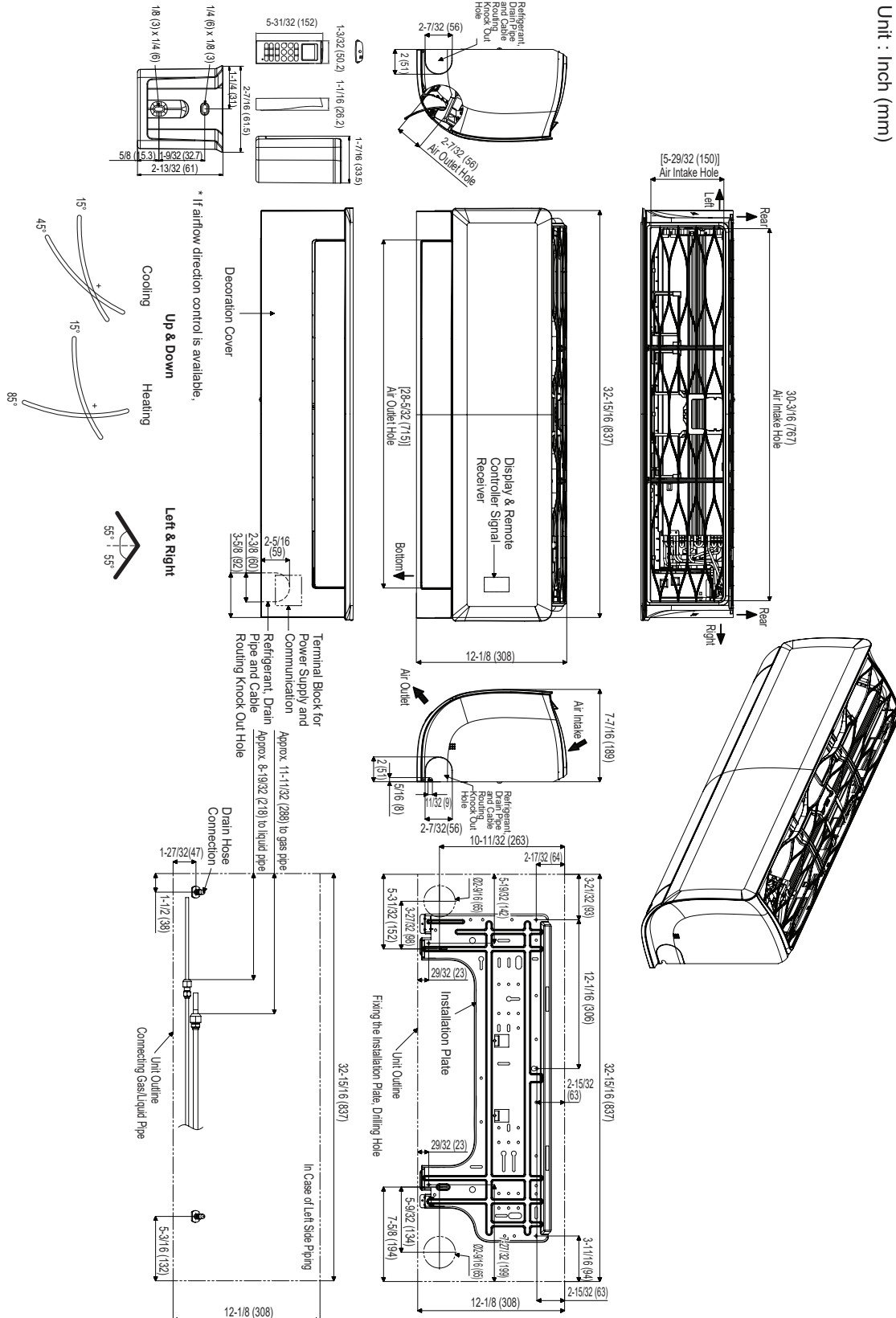

STANDARD WALL-MOUNTED INDOOR UNITS

MULTI F
MULTI F MAX

Dimensions

Figure 62: LSN180HSV5 and LMN249HVT Dimensions.

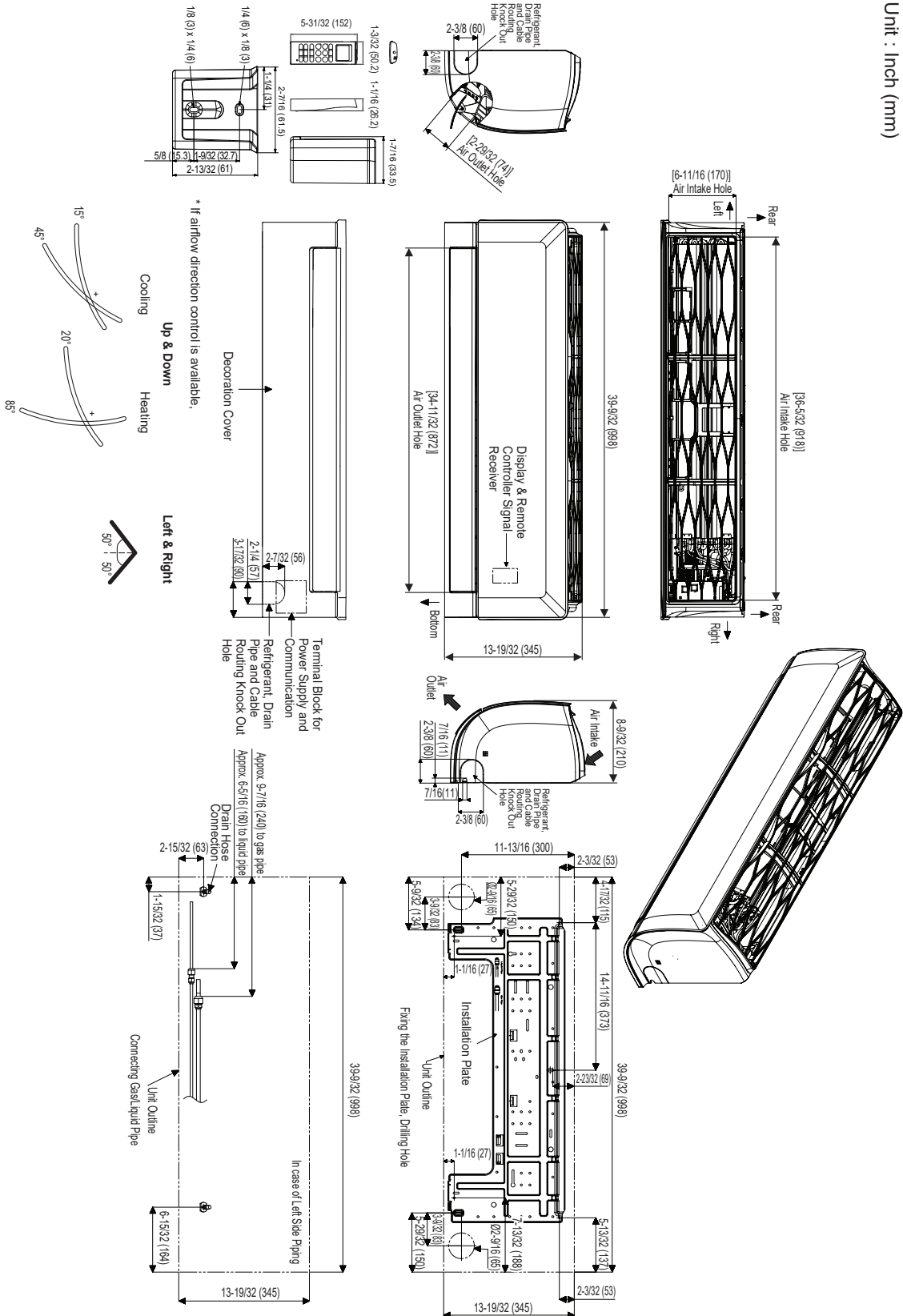

Table 22: Multi F Standard Wall-Mounted Indoor Units Cooling Capacity Table.

Model No. / Nominal Capacity of Indoor Unit (Btu/h)	Outdoor Air Temp. (°F DB)	Indoor Air Temp. °F DB / °F WB											
		68 / 57		73 / 61		77 / 64		80 / 67		86 / 72		90 / 75	
		TC	SHC	TC	SHC	TC	SHC	TC	SHC	TC	SHC	TC	SHC
LMN079HVT 7,000	14	6.86	4.68	7.29	4.95	7.71	4.79	8.02	4.89	8.57	4.93	8.99	5.03
	20	6.86	4.72	7.28	4.99	7.71	4.83	8.02	4.93	8.56	4.97	8.99	5.06
	25	6.85	4.76	7.28	5.02	7.70	4.86	8.01	4.97	8.55	5.01	8.98	5.10
	30	6.85	4.79	7.27	5.06	7.70	4.90	8.00	5.01	8.55	5.05	8.97	5.14
	35	6.84	4.83	7.27	5.10	7.69	4.94	8.00	5.04	8.54	5.09	8.97	5.18
	40	6.84	4.87	7.26	5.14	7.68	4.98	7.99	5.08	8.53	5.12	8.96	5.22
	45	6.83	4.90	7.25	5.18	7.68	5.01	7.99	5.12	8.53	5.16	8.95	5.26
	50	6.83	4.94	7.25	5.22	7.67	5.05	7.98	5.16	8.52	5.20	8.94	5.30
	55	6.82	4.97	7.24	5.25	7.67	5.09	7.97	5.19	8.51	5.24	8.94	5.34
	60	6.81	5.01	7.24	5.29	7.66	5.12	7.97	5.23	8.51	5.28	8.93	5.38
	65	6.81	5.05	7.23	5.33	7.66	5.16	7.96	5.27	8.50	5.31	8.92	5.42
	70	6.80	5.08	7.23	5.37	7.65	5.20	7.95	5.31	8.49	5.35	8.92	5.45
	75	6.64	5.00	7.06	5.29	7.48	5.13	7.79	5.24	8.33	5.29	8.75	5.39
	80	6.48	4.91	6.90	5.20	7.32	5.05	7.62	5.16	8.16	5.22	8.58	5.33
	85	6.31	4.82	6.73	5.12	7.15	4.97	7.46	5.09	7.99	5.15	8.41	5.26
	90	6.15	4.73	6.57	5.03	6.99	4.89	7.29	5.01	7.83	5.08	8.24	5.19
	95	5.98	4.68	6.39	4.98	6.81	4.85	7.00	4.90	7.64	5.05	8.06	5.17
	100	5.83	4.56	6.25	4.86	6.66	4.74	6.91	4.82	7.50	4.94	7.91	5.06
	105	5.69	4.43	6.10	4.73	6.52	4.62	6.82	4.75	7.35	4.83	7.77	4.96
	110	5.54	4.28	5.96	4.58	6.37	4.48	6.67	4.61	7.21	4.70	7.62	4.82
115	5.39	4.15	5.81	4.45	6.23	4.36	6.53	4.49	7.06	4.58	7.48	4.71	
118	5.31	4.12	5.72	4.42	6.14	4.34	6.44	4.47	6.97	4.57	7.39	4.70	
122	5.28	4.11	5.69	4.41	6.11	4.33	6.41	4.46	6.94	4.56	7.36	4.70	
LSN090HSV5 9,000	14	8.82	6.04	9.37	6.38	9.92	6.18	10.31	6.31	11.01	6.36	11.56	6.48
	20	8.82	6.09	9.36	6.43	9.91	6.23	10.31	6.36	11.01	6.41	11.55	6.53
	25	8.81	6.13	9.36	6.48	9.90	6.27	10.30	6.41	11.00	6.46	11.54	6.58
	30	8.80	6.18	9.35	6.53	9.90	6.32	10.29	6.46	10.99	6.51	11.54	6.63
	35	8.80	6.23	9.34	6.58	9.89	6.37	10.28	6.50	10.98	6.56	11.53	6.68
	40	8.79	6.28	9.33	6.63	9.88	6.42	10.27	6.55	10.97	6.61	11.52	6.73
	45	8.78	6.32	9.33	6.68	9.87	6.47	10.27	6.60	10.96	6.66	11.51	6.78
	50	8.78	6.37	9.32	6.73	9.87	6.51	10.26	6.65	10.96	6.71	11.50	6.83
	55	8.77	6.42	9.31	6.78	9.86	6.56	10.25	6.70	10.95	6.76	11.49	6.88
	60	8.76	6.46	9.31	6.83	9.85	6.61	10.24	6.75	10.94	6.81	11.48	6.93
	65	8.76	6.51	9.30	6.88	9.84	6.66	10.24	6.80	10.93	6.85	11.47	6.98
	70	8.75	6.56	9.29	6.92	9.84	6.70	10.23	6.85	10.92	6.90	11.47	7.03
	75	8.54	6.45	9.08	6.82	9.62	6.61	10.01	6.75	10.71	6.82	11.25	6.96
	80	8.33	6.34	8.87	6.71	9.41	6.51	9.80	6.66	10.49	6.73	11.03	6.87
	85	8.12	6.22	8.66	6.60	9.20	6.41	9.59	6.56	10.28	6.64	10.82	6.79
	90	7.91	6.10	8.45	6.48	8.99	6.31	9.37	6.46	10.06	6.55	10.60	6.70
	95	7.68	6.04	8.22	6.43	8.75	6.26	9.00	6.32	9.83	6.52	10.36	6.67
	100	7.50	5.88	8.03	6.26	8.57	6.11	8.88	6.22	9.64	6.37	10.17	6.53
	105	7.31	5.72	7.84	6.10	8.38	5.96	8.77	6.12	9.45	6.23	9.99	6.39
	110	7.12	5.52	7.66	5.90	8.19	5.78	8.58	5.94	9.26	6.06	9.80	6.22
115	6.94	5.36	7.47	5.74	8.01	5.63	8.39	5.79	9.08	5.91	9.61	6.08	
118	6.82	5.32	7.36	5.70	7.89	5.60	8.28	5.76	8.96	5.89	9.50	6.06	
122	6.79	5.30	7.32	5.69	7.86	5.59	8.24	5.76	8.93	5.89	9.46	6.06	

TC = Total Capacity (kBtu/h).

SHC: Sensible Heat Capacity (kBtu/h).

Nominal capacity as rated 0 ft. above sea level and a 0 ft. level difference between outdoor and indoor units. Corresponding refrigerant piping length is accordance with standard length of each outdoor unit.

Nominal cooling capacity rating obtained with air entering the indoor unit at 80°F dry bulb (DB) and 67°F wet bulb (WB), and outdoor ambient conditions of 95°F dry bulb (DB) and 75°F wet bulb (WB).

The shaded table columns and rows indicate reference data. When operating at this temperature, these values can be different if the system is not running consistently.

Standard Wall-Mounted

STANDARD WALL-MOUNTED INDOOR UNITS

MULTI F
MULTI F MAX

Cooling Capacity Table

Table 23: Multi F Standard Wall-Mounted Indoor Units Cooling Capacity Table (continued).

Model No. / Nominal Capacity of Indoor Unit (Btu/h)	Outdoor Air Temp. (°F DB)	Indoor Air Temp. °F DB / °F WB											
		68 / 57		73 / 61		77 / 64		80 / 67		86 / 72		90 / 75	
		TC	SHC	TC	SHC	TC	SHC	TC	SHC	TC	SHC	TC	SHC
LSN120HSV5 12,000	14	11.76	8.51	12.49	8.99	13.22	8.70	13.75	8.88	14.69	8.96	15.42	9.13
	20	11.75	8.57	12.48	9.06	13.21	8.77	13.74	8.95	14.67	9.03	15.40	9.20
	25	11.75	8.64	12.48	9.13	13.20	8.84	13.73	9.02	14.66	9.10	15.39	9.27
	30	11.74	8.71	12.47	9.20	13.19	8.90	13.72	9.09	14.65	9.17	15.38	9.34
	35	11.73	8.77	12.46	9.27	13.18	8.97	13.71	9.16	14.64	9.24	15.37	9.41
	40	11.72	8.84	12.45	9.34	13.17	9.04	13.70	9.23	14.63	9.31	15.36	9.48
	45	11.71	8.90	12.44	9.41	13.16	9.11	13.69	9.30	14.62	9.38	15.35	9.55
	50	11.70	8.97	12.43	9.47	13.15	9.17	13.68	9.37	14.61	9.45	15.33	9.62
	55	11.69	9.03	12.42	9.54	13.14	9.24	13.67	9.44	14.60	9.52	15.32	9.70
	60	11.68	9.10	12.41	9.61	13.13	9.31	13.66	9.50	14.59	9.58	15.31	9.77
	65	11.67	9.17	12.40	9.68	13.12	9.38	13.65	9.57	14.57	9.65	15.30	9.84
	70	11.66	9.23	12.39	9.75	13.11	9.44	13.64	9.64	14.56	9.72	15.29	9.91
	75	11.38	9.08	12.11	9.60	12.83	9.31	13.35	9.51	14.27	9.60	15.00	9.79
	80	11.10	8.92	11.82	9.45	12.55	9.17	13.07	9.38	13.99	9.48	14.71	9.68
	85	10.83	8.76	11.54	9.29	12.26	9.03	12.78	9.24	13.70	9.36	14.42	9.56
	90	10.55	8.60	11.26	9.13	11.98	8.88	12.50	9.10	13.42	9.22	14.13	9.43
	95	10.25	8.51	10.96	9.05	11.67	8.82	12.00	8.90	13.10	9.18	13.81	9.39
	100	10.00	8.28	10.71	8.82	11.42	8.61	11.84	8.76	12.85	8.98	13.56	9.20
	105	9.75	8.05	10.46	8.59	11.17	8.40	11.69	8.62	12.60	8.78	13.31	9.01
	110	9.50	7.77	10.21	8.31	10.92	8.14	11.44	8.37	12.35	8.53	13.07	8.76
115	9.25	7.54	9.96	8.08	10.67	7.92	11.19	8.15	12.10	8.33	12.82	8.56	
118	9.10	7.49	9.81	8.03	10.52	7.88	11.04	8.12	11.95	8.30	12.67	8.54	
122	9.05	7.47	9.76	8.01	10.48	7.87	10.99	8.11	11.90	8.29	12.62	8.53	
LMN159HVT 14,300	14	14.02	10.23	14.89	10.80	15.76	10.46	16.39	10.68	17.50	10.77	18.37	10.97
	20	14.01	10.31	14.88	10.89	15.75	10.54	16.38	10.76	17.49	10.85	18.36	11.06
	25	14.00	10.39	14.87	10.97	15.74	10.62	16.36	10.85	17.47	10.94	18.34	11.15
	30	13.99	10.47	14.85	11.06	15.72	10.70	16.35	10.93	17.46	11.02	18.33	11.23
	35	13.98	10.55	14.84	11.14	15.71	10.79	16.34	11.01	17.45	11.11	18.32	11.32
	40	13.96	10.62	14.83	11.22	15.70	10.87	16.33	11.10	17.43	11.19	18.30	11.40
	45	13.95	10.70	14.82	11.31	15.69	10.95	16.31	11.18	17.42	11.27	18.29	11.49
	50	13.94	10.78	14.81	11.39	15.68	11.03	16.30	11.26	17.41	11.36	18.27	11.57
	55	13.93	10.86	14.80	11.47	15.66	11.11	16.29	11.34	17.39	11.44	18.26	11.66
	60	13.92	10.94	14.79	11.56	15.65	11.19	16.28	11.43	17.38	11.52	18.25	11.74
	65	13.91	11.02	14.78	11.64	15.64	11.27	16.26	11.51	17.37	11.61	18.23	11.83
	70	13.90	11.10	14.76	11.72	15.63	11.35	16.25	11.59	17.35	11.69	18.22	11.91
	75	13.57	10.92	14.43	11.55	15.29	11.19	15.91	11.44	17.01	11.55	17.87	11.78
	80	13.23	10.73	14.09	11.36	14.95	11.03	15.57	11.28	16.67	11.40	17.53	11.64
	85	12.90	10.53	13.76	11.17	14.61	10.86	15.23	11.11	16.33	11.25	17.18	11.49
	90	12.57	10.33	13.42	10.98	14.28	10.68	14.90	10.94	15.99	11.09	16.84	11.34
	95	12.21	10.23	13.06	10.88	13.91	10.60	14.30	10.70	15.61	11.03	16.46	11.29
	100	11.91	9.95	12.76	10.60	13.61	10.35	14.11	10.53	15.31	10.79	16.16	11.06
	105	11.61	9.68	12.46	10.33	13.32	10.09	13.93	10.37	15.02	10.56	15.87	10.83
	110	11.32	9.35	12.17	10.00	13.02	9.78	13.63	10.06	14.72	10.26	15.57	10.53
115	11.02	9.07	11.87	9.71	12.72	9.52	13.33	9.80	14.42	10.01	15.27	10.29	
118	10.84	9.00	11.69	9.66	12.54	9.48	13.16	9.76	14.24	9.98	15.09	10.26	
122	10.78	8.98	11.63	9.64	12.48	9.46	13.10	9.74	14.18	9.97	15.03	10.25	

TC = Total Capacity (kBtu/h).

SHC: Sensible Heat Capacity (kBtu/h).

Nominal capacity as rated 0 ft. above sea level and a 0 ft. level difference between outdoor and indoor units. Corresponding refrigerant piping length is accordance with standard length of each outdoor unit.

Nominal cooling capacity rating obtained with air entering the indoor unit at 80°F dry bulb (DB) and 67°F wet bulb (WB), and outdoor ambient conditions of 95°F dry bulb (DB) and 75°F wet bulb (WB).

The shaded table columns and rows indicate reference data. When operating at this temperature, these values can be different if the system is not running consistently.



Table 24: Multi F Standard Wall-Mounted Indoor Units Cooling Capacity Table (continued).

Model No. / Nominal Capacity of Indoor Unit (Btu/h)	Outdoor Air Temp. (°F DB)	Indoor Air Temp. °F DB / °F WB											
		68 / 57		73 / 61		77 / 64		80 / 67		86 / 72		90 / 75	
		TC	SHC	TC	SHC	TC	SHC	TC	SHC	TC	SHC	TC	SHC
LSN180HSV5 18,000	14	17.65	12.33	18.74	13.02	19.84	12.61	20.63	12.88	22.03	12.98	23.12	13.23
	20	17.63	12.43	18.73	13.13	19.82	12.71	20.61	12.98	22.01	13.09	23.11	13.33
	25	17.62	12.52	18.71	13.23	19.81	12.81	20.60	13.08	22.00	13.19	23.09	13.44
	30	17.60	12.62	18.70	13.33	19.79	12.91	20.58	13.18	21.98	13.29	23.07	13.54
	35	17.59	12.71	18.68	13.43	19.78	13.00	20.57	13.28	21.96	13.39	23.05	13.64
	40	17.58	12.81	18.67	13.53	19.76	13.10	20.55	13.38	21.94	13.49	23.04	13.75
	45	17.56	12.90	18.66	13.63	19.75	13.20	20.53	13.48	21.93	13.59	23.02	13.85
	50	17.55	13.00	18.64	13.73	19.73	13.30	20.52	13.58	21.91	13.69	23.00	13.95
	55	17.54	13.10	18.63	13.83	19.72	13.39	20.50	13.68	21.89	13.79	22.98	14.05
	60	17.52	13.19	18.61	13.93	19.70	13.49	20.49	13.78	21.88	13.89	22.97	14.16
	65	17.51	13.29	18.60	14.03	19.69	13.59	20.47	13.87	21.86	13.99	22.95	14.26
	70	17.50	13.38	18.58	14.13	19.67	13.69	20.46	13.97	21.84	14.09	22.93	14.36
	75	17.08	13.16	18.16	13.92	19.24	13.49	20.03	13.79	21.41	13.92	22.50	14.20
	80	16.66	12.93	17.74	13.70	18.82	13.30	19.60	13.60	20.98	13.75	22.06	14.03
	85	16.24	12.70	17.32	13.47	18.40	13.09	19.17	13.40	20.55	13.56	21.63	13.85
	90	15.82	12.46	16.90	13.23	17.97	12.88	18.75	13.19	20.12	13.37	21.20	13.67
	95	15.37	12.33	16.44	13.12	17.51	12.78	18.00	12.90	19.65	13.30	20.72	13.61
	100	14.99	12.00	16.06	12.78	17.13	12.47	17.77	12.70	19.28	13.01	20.35	13.33
105	14.62	11.67	15.69	12.45	16.76	12.17	17.53	12.50	18.90	12.73	19.97	13.05	
110	14.24	11.27	15.32	12.05	16.39	11.79	17.16	12.13	18.53	12.36	19.60	12.70	
115	13.87	10.93	14.94	11.71	16.01	11.48	16.79	11.82	18.15	12.07	19.22	12.41	
118	13.65	10.85	14.72	11.64	15.79	11.42	16.56	11.77	17.93	12.03	19.00	12.37	
122	13.57	10.83	14.64	11.62	15.71	11.40	16.49	11.75	17.85	12.01	18.92	12.36	
LMN249HVT 24,000	14	23.53	16.82	24.99	17.77	26.45	17.21	27.50	17.57	29.37	17.72	30.83	18.05
	20	23.51	16.95	24.97	17.91	26.43	17.34	27.48	17.70	29.35	17.85	30.81	18.19
	25	23.49	17.08	24.95	18.05	26.41	17.47	27.46	17.84	29.33	17.99	30.79	18.33
	30	23.47	17.21	24.93	18.19	26.39	17.61	27.44	17.98	29.30	18.13	30.76	18.47
	35	23.46	17.35	24.91	18.32	26.37	17.74	27.42	18.12	29.28	18.27	30.74	18.61
	40	23.44	17.48	24.89	18.46	26.35	17.88	27.40	18.25	29.26	18.41	30.72	18.75
	45	23.42	17.61	24.87	18.60	26.33	18.01	27.38	18.39	29.24	18.54	30.69	18.89
	50	23.40	17.74	24.85	18.74	26.31	18.14	27.36	18.52	29.21	18.68	30.67	19.03
	55	23.38	17.87	24.84	18.87	26.29	18.27	27.34	18.66	29.19	18.82	30.64	19.17
	60	23.37	18.00	24.82	19.01	26.27	18.41	27.32	18.79	29.17	18.95	30.62	19.31
	65	23.35	18.13	24.80	19.15	26.25	18.54	27.29	18.93	29.15	19.09	30.60	19.45
	70	23.33	18.26	24.78	19.28	26.23	18.67	27.27	19.07	29.13	19.23	30.57	19.59
	75	22.77	17.95	24.21	18.99	25.66	18.41	26.70	18.81	28.55	18.99	29.99	19.37
	80	22.21	17.65	23.65	18.69	25.09	18.14	26.13	18.55	27.97	18.75	29.42	19.14
	85	21.65	17.33	23.09	18.38	24.53	17.86	25.57	18.28	27.40	18.50	28.84	18.90
	90	21.09	17.00	22.53	18.06	23.96	17.57	25.00	18.00	26.83	18.24	28.27	18.65
	95	20.49	16.82	21.92	17.89	23.35	17.44	24.00	17.60	26.20	18.14	27.63	18.57
	100	19.99	16.37	21.42	17.44	22.85	17.02	23.69	17.33	25.70	17.75	27.13	18.19
105	19.49	15.92	20.92	16.99	22.35	16.60	23.38	17.06	25.20	17.36	26.63	17.81	
110	18.99	15.38	20.42	16.44	21.85	16.09	22.88	16.55	24.70	16.87	26.13	17.32	
115	18.49	14.91	19.92	15.98	21.35	15.66	22.38	16.12	24.20	16.47	25.63	16.93	
118	18.19	14.81	19.62	15.88	21.05	15.59	22.08	16.05	23.90	16.41	25.33	16.88	
122	18.10	14.77	19.52	15.85	20.95	15.56	21.98	16.03	23.81	16.39	25.23	16.86	

TC = Total Capacity (kBtu/h).

SHC: Sensible Heat Capacity (kBtu/h).

Nominal capacity as rated 0 ft. above sea level and a 0 ft. level difference between outdoor and indoor units. Corresponding refrigerant piping length is accordance with standard length of each outdoor unit.

Nominal cooling capacity rating obtained with air entering the indoor unit at 80°F dry bulb (DB) and 67°F wet bulb (WB), and outdoor ambient conditions of 95°F dry bulb (DB) and 75°F wet bulb (WB).

The shaded table columns and rows indicate reference data. When operating at this temperature, these values can be different if the system is not running consistently.

Standard Wall-Mounted

STANDARD WALL-MOUNTED INDOOR UNITS

MULTI F
MULTI F MAX

Heating Capacity Table

Table 25: Multi F Standard Wall-Mounted Indoor Units Heating Capacity Table.

Model No. / Nominal Capacity of Indoor Unit (Btu/h)	Outdoor Air Temp.		Indoor Air Temp. °F DB					
	°F DB	°F WB	61	64	68	70	72	75
			TC	TC	TC	TC	TC	TC
LMN079HVT 8,100	0	-0.4	4.17	4.11	4.07	4.05	3.99	3.82
	5	4.5	4.70	4.64	4.60	4.58	4.52	4.34
	10	9	5.22	5.17	5.13	5.11	5.05	4.87
	17	15	5.93	5.87	5.83	5.81	5.75	5.56
	20	19	6.19	6.13	6.09	6.08	6.02	5.81
	25	23	6.63	6.57	6.53	6.52	6.46	6.22
	30	28	7.01	6.96	6.92	6.90	6.84	6.63
	35	32	7.40	7.34	7.30	7.28	7.22	7.04
	40	36	7.74	7.68	7.64	7.62	7.56	7.39
	45	41	8.08	8.02	7.98	7.96	7.90	7.73
	47	43	8.22	8.16	8.12	8.10	8.04	7.87
	50	46	8.35	8.29	8.25	8.23	8.17	7.98
	55	51	8.57	8.51	8.47	8.45	8.39	8.16
	60	56	8.57	8.51	8.47	8.45	8.39	8.20
	63	59	8.57	8.51	8.47	8.45	8.39	8.22
	68	64	8.57	8.51	8.47	8.45	8.39	8.25
LSN090HSV5 10,900	0	-0.4	5.61	5.53	5.48	5.45	5.37	5.14
	5	4.5	6.32	6.24	6.18	6.16	6.08	5.85
	10	9	7.03	6.95	6.90	6.88	6.79	6.56
	17	15	7.98	7.90	7.85	7.82	7.75	7.48
	20	19	8.33	8.26	8.21	8.18	8.09	7.82
	25	23	8.93	8.85	8.79	8.77	8.69	8.37
	30	28	9.44	9.36	9.31	9.29	9.20	8.93
	35	32	9.96	9.87	9.82	9.79	9.72	9.47
	40	36	10.42	10.33	10.28	10.25	10.18	9.94
	45	41	10.87	10.80	10.74	10.71	10.64	10.40
	47	43	11.06	10.98	10.93	10.90	10.82	10.59
	50	46	11.24	11.15	11.10	11.08	10.99	10.73
	55	51	11.53	11.46	11.40	11.37	11.30	10.98
	60	56	11.53	11.46	11.40	11.37	11.30	11.03
	63	59	11.53	11.46	11.40	11.37	11.30	11.06
	68	64	11.53	11.46	11.40	11.37	11.30	11.11
LSN120HSV5 13,600	0	-0.4	7.00	6.90	6.83	6.80	6.70	6.50
	5	4.5	7.89	7.78	7.71	7.69	7.59	7.40
	10	9	8.78	8.67	8.60	8.58	8.48	8.31
	17	15	9.95	9.86	9.79	9.76	9.67	9.47
	20	19	10.40	10.30	10.23	10.20	10.10	9.90
	25	23	11.14	11.03	10.96	10.95	10.85	10.60
	30	28	11.78	11.67	11.60	11.59	11.49	11.30
	35	32	12.42	12.31	12.24	12.21	12.13	11.99
	40	36	13.00	12.89	12.82	12.79	12.70	12.58
	45	41	13.56	13.46	13.39	13.36	13.28	13.16
	47	43	13.80	13.70	13.63	13.60	13.50	13.40
	50	46	14.02	13.91	13.84	13.82	13.72	13.59
	55	51	14.39	14.29	14.22	14.19	14.10	13.90
	60	56	14.39	14.29	14.22	14.19	14.10	13.96
	63	59	14.39	14.29	14.22	14.19	14.10	14.00
	68	64	14.39	14.29	14.22	14.19	14.10	14.06

TC = Total Capacity (kBtu/h).

Nominal capacity as rated 0 ft. above sea level and a 0 ft. level difference between outdoor and indoor units. Corresponding refrigerant piping length is accordance with standard length of each outdoor unit. Nominal heating capacity rating obtained with air entering the indoor unit at 70°F dry bulb (DB) and 60°F wet bulb (WB), and outdoor ambient conditions of 47°F dry bulb (DB) and 43°F wet bulb (WB).

Table 26: Multi F Standard Wall-Mounted Indoor Units Heating Capacity Table.

Model No. / Nominal Capacity of Indoor Unit (Btu/h)	Outdoor Air Temp.		Indoor Air Temp. °F DB					
	°F DB	°F WB	61	64	68	70	72	75
			TC	TC	TC	TC	TC	TC
LMN159HVT 15,600	0	-0.4	8.03	7.91	7.84	7.80	7.69	7.35
	5	4.5	9.05	8.93	8.86	8.82	8.71	8.37
	10	9	10.06	9.95	9.87	9.83	9.72	9.38
	17	15	11.42	11.31	11.23	11.19	11.08	10.71
	20	19	10.03	11.81	11.73	11.70	11.59	11.19
	25	23	12.77	12.66	12.58	12.55	12.43	11.98
	30	28	13.51	13.40	13.32	13.28	13.17	12.77
	35	32	14.25	14.13	14.06	14.02	13.91	13.57
	40	36	14.90	14.79	14.71	14.67	14.56	14.23
	45	41	15.56	15.45	15.37	15.34	15.22	14.88
	47	43	15.83	15.71	15.64	15.60	15.49	15.15
	50	46	16.08	15.97	15.89	15.86	15.74	15.36
	55	51	16.51	16.39	16.32	16.28	16.17	15.71
	60	56	16.51	16.39	16.32	16.28	16.17	15.78
	63	59	16.51	16.39	16.32	16.28	16.17	15.83
68	64	16.51	16.39	16.32	16.28	16.17	15.89	
LSN180HSV5 21,600	0	-0.4	11.11	10.96	10.85	10.80	10.64	10.18
	5	4.5	12.52	12.37	12.26	12.21	12.06	11.58
	10	9	13.93	13.77	13.67	13.61	13.46	12.99
	17	15	15.81	15.65	15.55	15.49	15.34	14.84
	20	19	16.51	16.36	16.25	16.20	16.04	15.49
	25	23	17.69	17.53	17.43	17.37	17.22	16.59
	30	28	18.70	18.55	18.44	18.39	18.24	17.69
	35	32	19.72	19.56	19.46	19.41	19.25	18.79
	40	36	20.63	20.48	20.37	20.32	20.17	19.70
	45	41	21.55	21.39	21.29	21.24	21.08	20.61
	47	43	21.91	21.76	21.65	21.60	21.44	20.98
	50	46	22.26	22.11	22.01	21.95	21.80	21.27
	55	51	22.86	22.70	22.59	22.53	22.38	21.76
	60	56	22.86	22.70	22.59	22.53	22.38	21.85
	63	59	22.86	22.70	22.59	22.53	22.38	21.91
68	64	22.86	22.70	22.59	22.53	22.38	22.02	
LMN249HVT 25,600	0	-0.4	13.17	12.99	12.87	12.80	12.61	12.06
	5	4.5	14.84	14.66	14.54	14.47	14.29	13.73
	10	9	16.51	16.33	16.20	16.14	15.96	15.40
	17	15	18.74	18.56	18.42	18.37	18.18	17.59
	20	19	19.57	19.39	19.27	19.20	19.01	18.37
	25	23	20.96	20.77	20.65	20.59	20.40	19.66
	30	28	22.17	21.98	21.85	21.80	21.61	20.96
	35	32	23.37	23.19	23.07	23.00	22.82	22.26
	40	36	24.45	24.27	24.15	24.08	23.90	23.34
	45	41	25.53	25.35	25.23	25.16	24.98	24.42
	47	43	25.97	25.79	25.67	25.60	25.41	24.86
	50	46	26.39	26.21	26.08	26.02	25.83	25.20
	55	51	27.09	26.90	26.78	26.71	26.53	25.79
	60	56	27.09	26.90	26.78	26.71	26.53	25.90
	63	59	27.09	26.90	26.78	26.71	26.53	25.97
68	64	27.09	26.90	26.78	26.71	26.53	26.08	

TC = Total Capacity (kBtu/h).

Nominal capacity as rated 0 ft. above sea level and a 0 ft. level difference between outdoor and indoor units. Corresponding refrigerant piping length is accordance with standard length of each outdoor unit.
Nominal heating capacity rating obtained with air entering the indoor unit at 70°F dry bulb (DB) and 60°F wet bulb (WB), and outdoor ambient conditions of 47°F dry bulb (DB) and 43°F wet bulb (WB).

Standard Wall-Mounted

STANDARD WALL-MOUNTED INDOOR UNITS

MULTI F
MULTI F MAX

Acoustic Data

Figure 63: Sound Pressure Level Measurement Location.

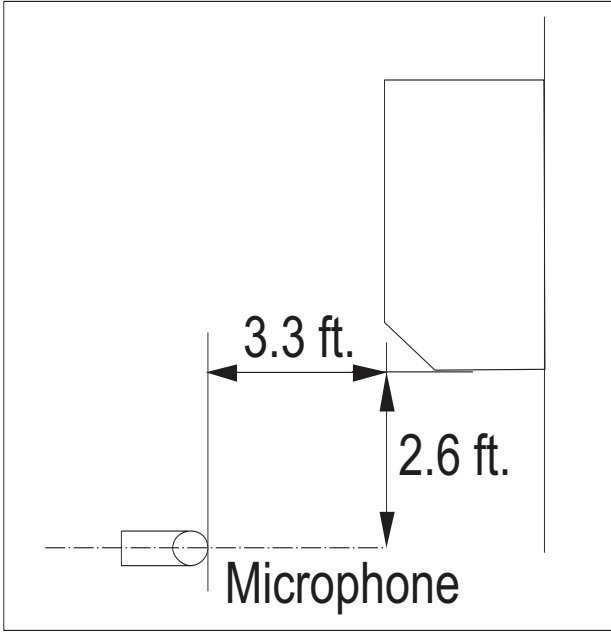

- Measurement taken 2.6' below the bottom of the unit and at a distance of 3.3' from face of unit.
- Measurements taken with no attenuation and units operating at full load normal operating condition.
- Sound level will vary depending on a range of factors such as construction (acoustic absorption coefficient) of particular area in which the equipment is installed.
- Sound power levels are measured in dB(A)±1.
- Tested in anechoic chamber per ISO Standard 3745.

Table 27: Sound Pressure Levels (dB[A]).

Model No.	Sound Pressure Levels (dB[A]) (Cooling and Heating)		
	High Fan Speed	Medium Fan Speed	Low Fan Speed
LMN079HVT	35	31	26
LSN090HSV5	36	32	27
LSN120HSV5	38	34	29
LMN159HVT	42	38	32
LSN180HSV5	44	38	34
LMN249HVT	46	41	36

Figure 64: LMN079HVT, LSN090HSV5, and LSN120HSV5 Sound Pressure Level Diagrams.

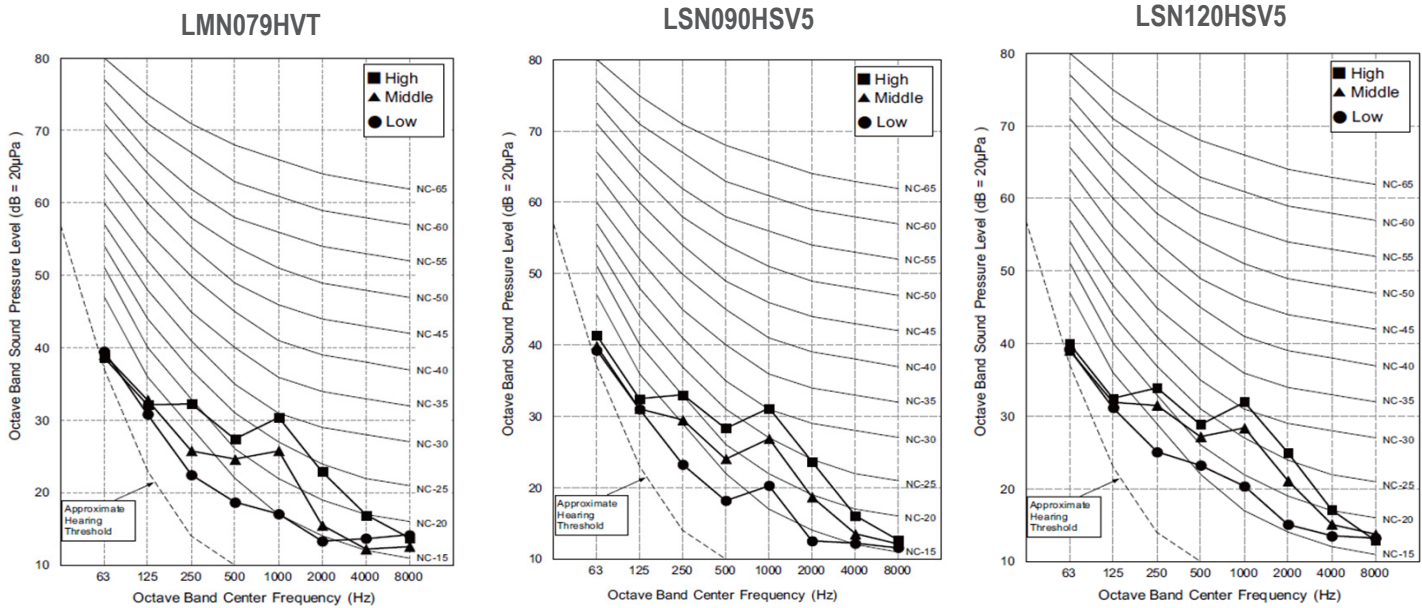
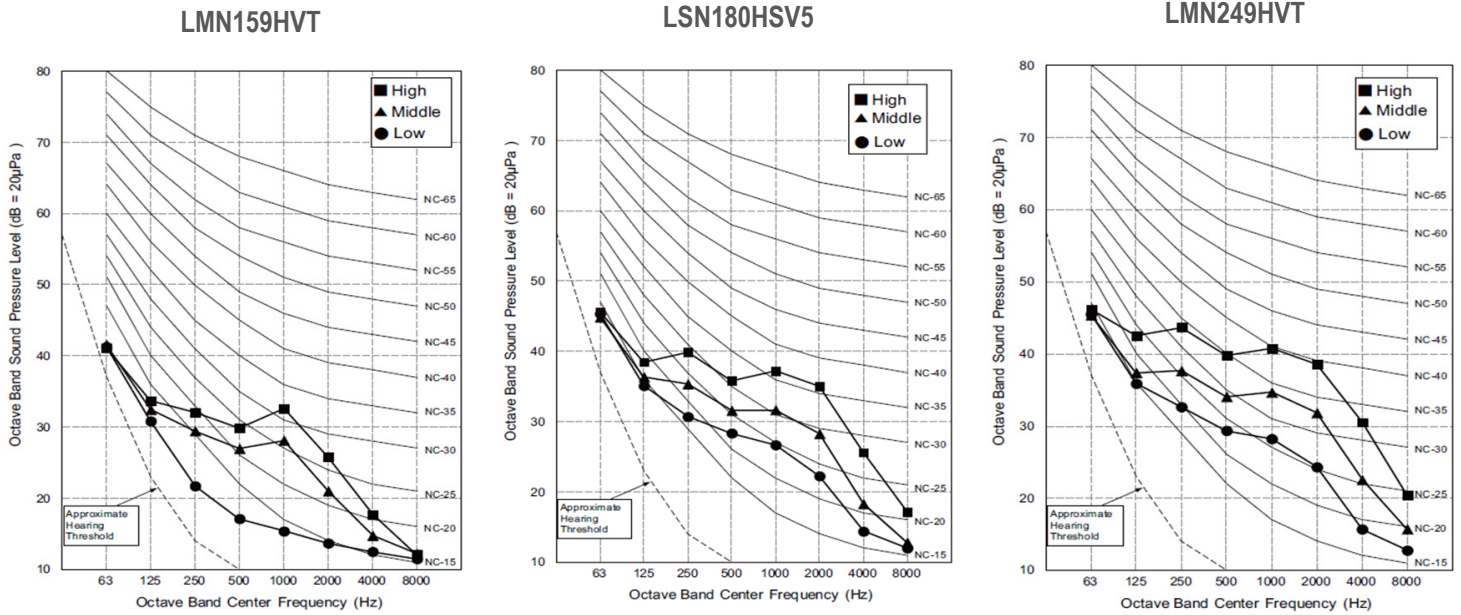

Figure 65: LMN159HVT, LSN180HSV5, and LMN249HVT Sound Pressure Level Diagrams.



Standard Wall-Mounted

STANDARD WALL-MOUNTED INDOOR UNITS

MULTI F
MULTI F MAX

Air Velocity and Temperature Distribution

Figure 66:LMN079HVT, LSN090HSV5, LSN120HSV5, LMN159HVT Air Velocity and Temperature Distribution Charts.

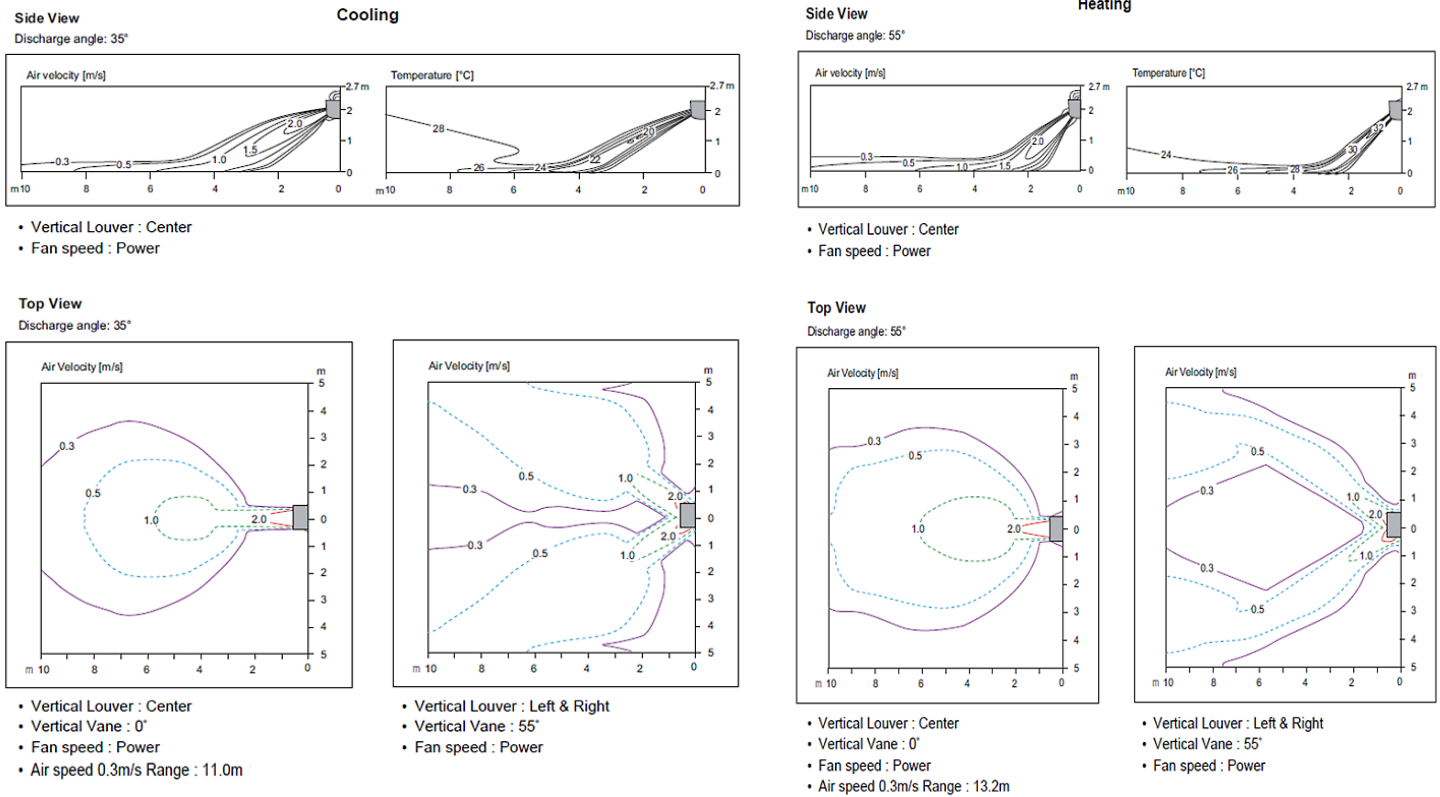

Figure 67:LSN180HSV5 Air Velocity and Temperature Distribution Charts.

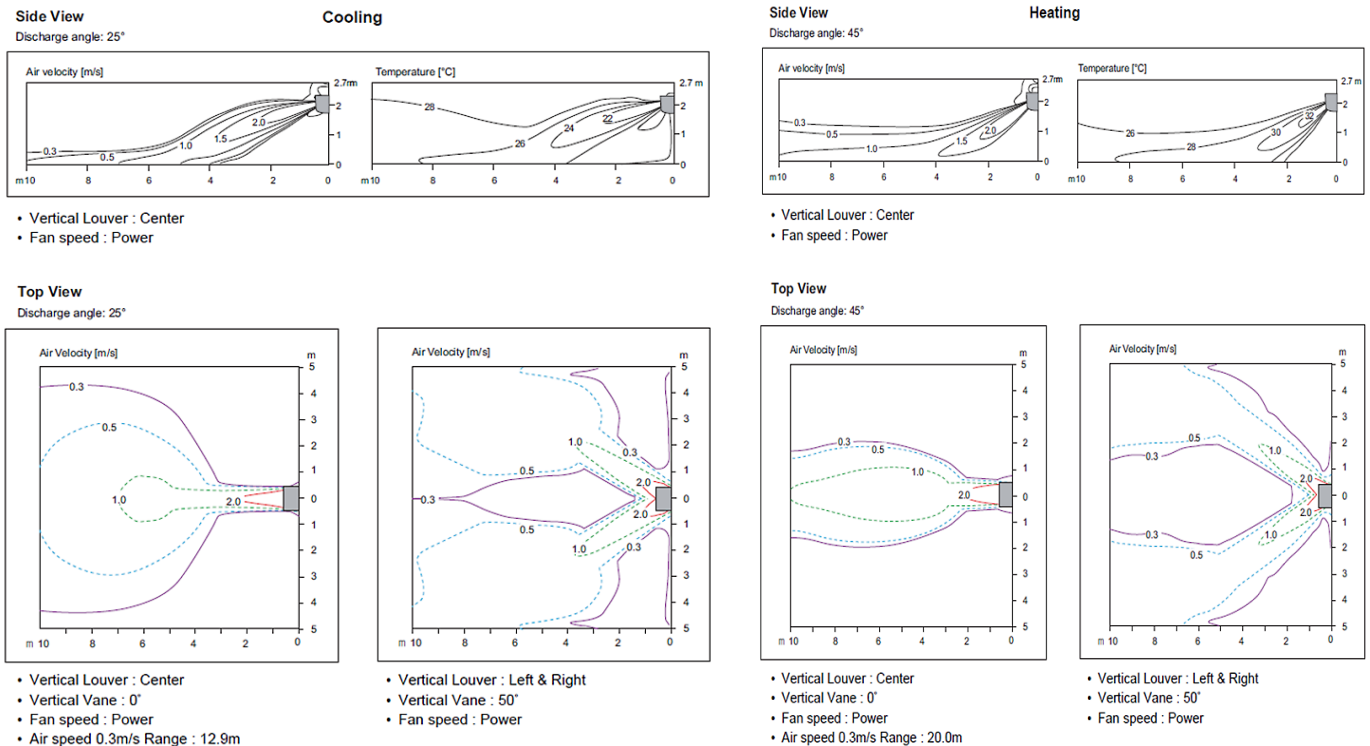
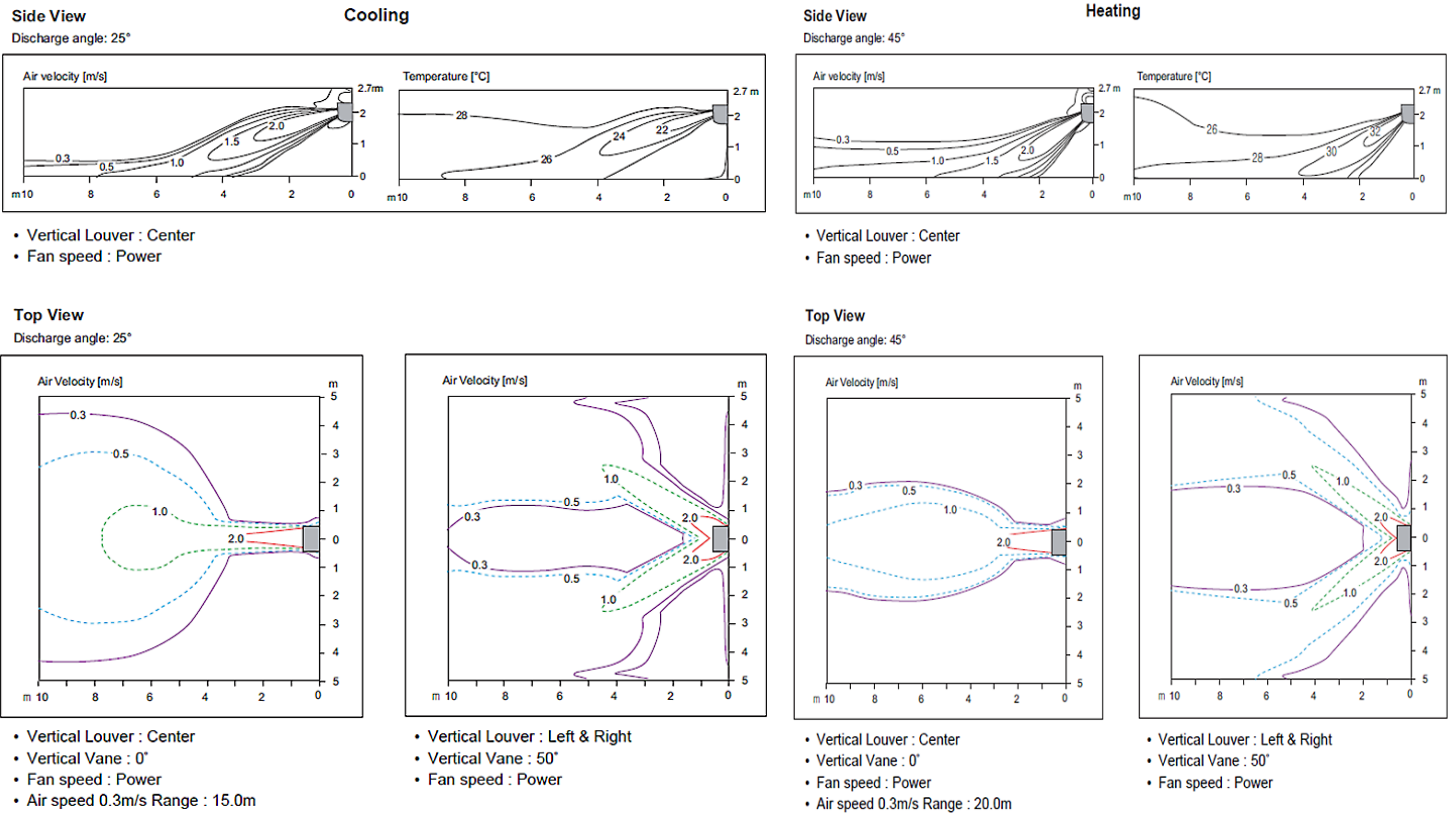

Figure 68:LMN249HVT Air Velocity and Temperature Distribution Charts.



STANDARD WALL-MOUNTED INDOOR UNITS

MULTI F
MULTI F MAX

Refrigerant Flow Diagram

Figure 69: Multi F Standard Wall-Mounted Indoor Unit Refrigerant Flow Diagram.

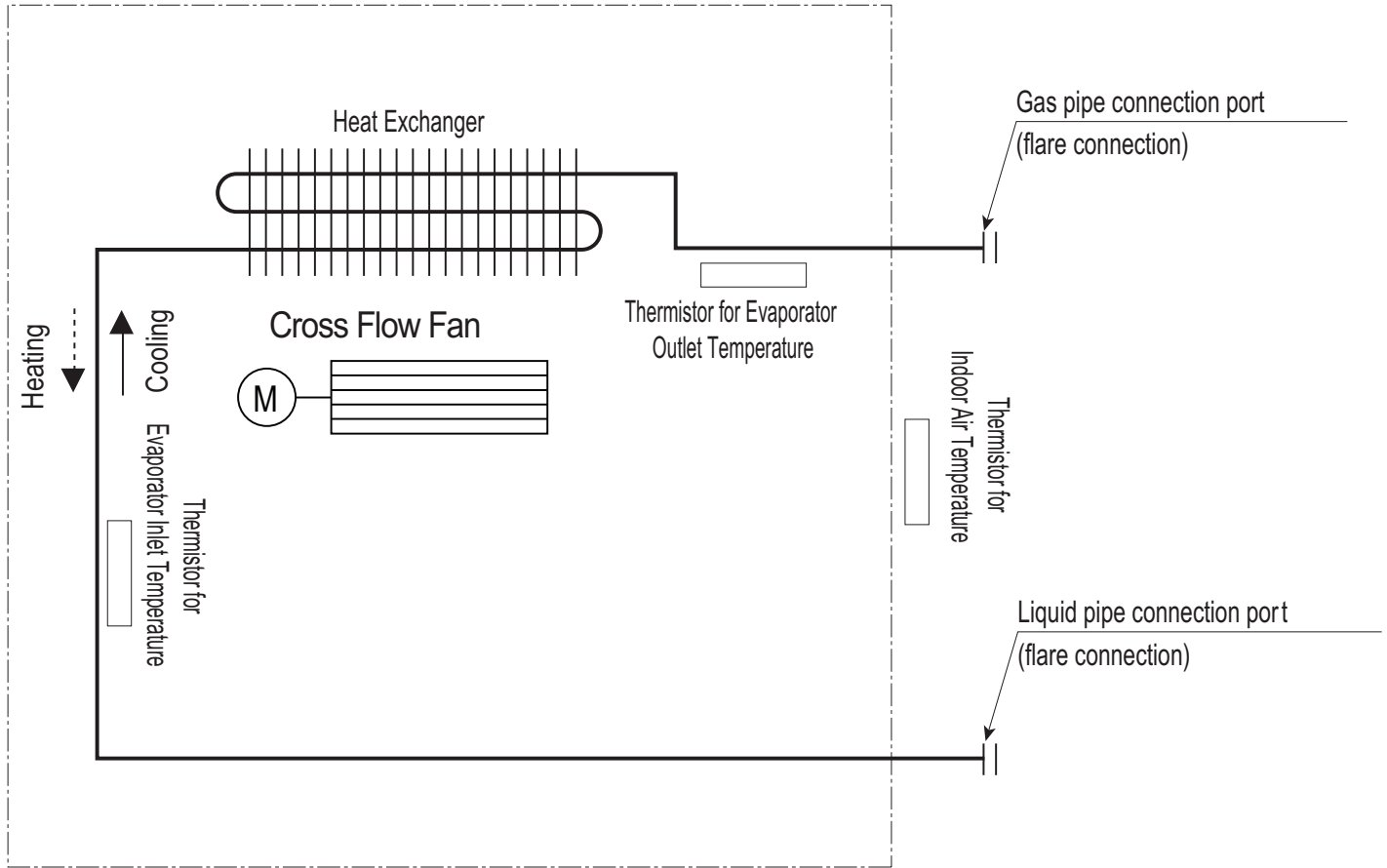

Table 28: Multi F Standard Wall-Mounted Indoor Unit Refrigerant Pipe Sizes.

Model No.	Vapor (inch)	Liquid (inch)
LMN079HVT	Ø3/8	Ø1/4
LSN090HSV5		
LSN120HSV5		
LMN159HVT		
LSN180HSV5	Ø1/2	
LMN249HVT		

Table 29: Multi F Standard Wall-Mounted Indoor Unit Refrigerant Pipe Connections.

Model No.	Vapor (inch)	Liquid (inch)
LMN079HVT	Ø3/8	Ø1/4
LSN090HSV5		
LSN120HSV5		
LMN159HVT		
LSN180HSV5	Ø5/8	Ø3/8
LMN249HVT	Ø1/2	Ø1/4

Table 30: Multi F LSNxxxHSV5 Standard Wall-Mounted Indoor Unit Thermistor Details.

Description (Based on Cooling Mode)	PCB Connector
Indoor Air Temperature Thermistor	CN-TH1
Evaporator Inlet Temperature Thermistor	
Evaporator Middle Temperature Thermistor	CN-TH2
Evaporator Outlet Temperature Thermistor	
Water Level Sensor (Optional)	CN-TH3

Table 31: Multi F LMNxxxHVT Standard Wall-Mounted Indoor Unit Thermistor Details.

Description (Based on Cooling Mode)	PCB Connector
Indoor Air Temperature Thermistor	CN-TH1
Evaporator Inlet Temperature Thermistor	
Evaporator Outlet Temperature Thermistor	CN-TH2
Water Level Sensor (Optional)	CN-TH3

Figure 70: Multi F Standard Wall-Mounted LSN090HSV5, LSN120HSV5, LSN180HSV5 Indoor Units Wiring Diagram.

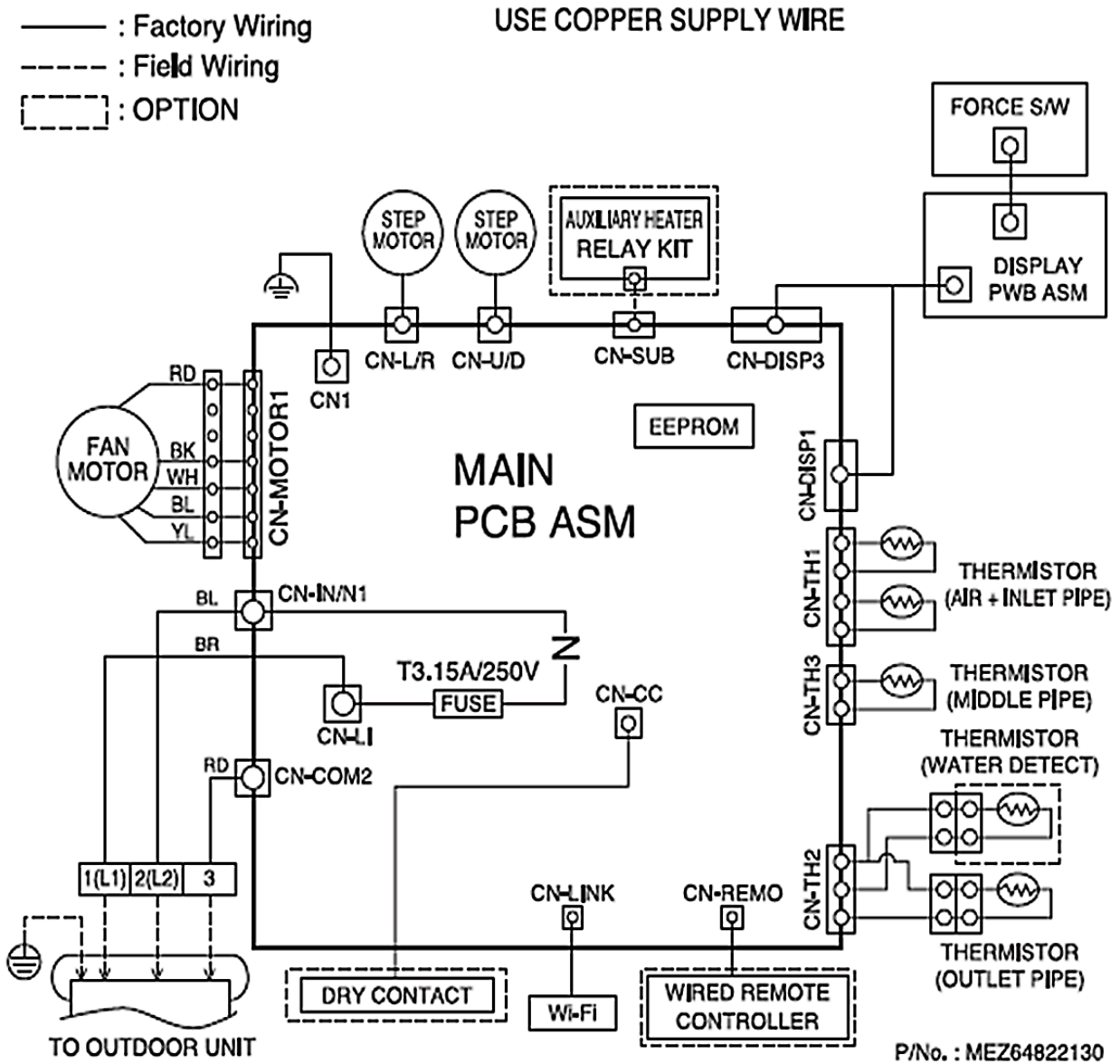

Standard Wall-Mounted

STANDARD WALL-MOUNTED INDOOR UNITS

MULTI F
MULTI F MAX

Wiring Diagram

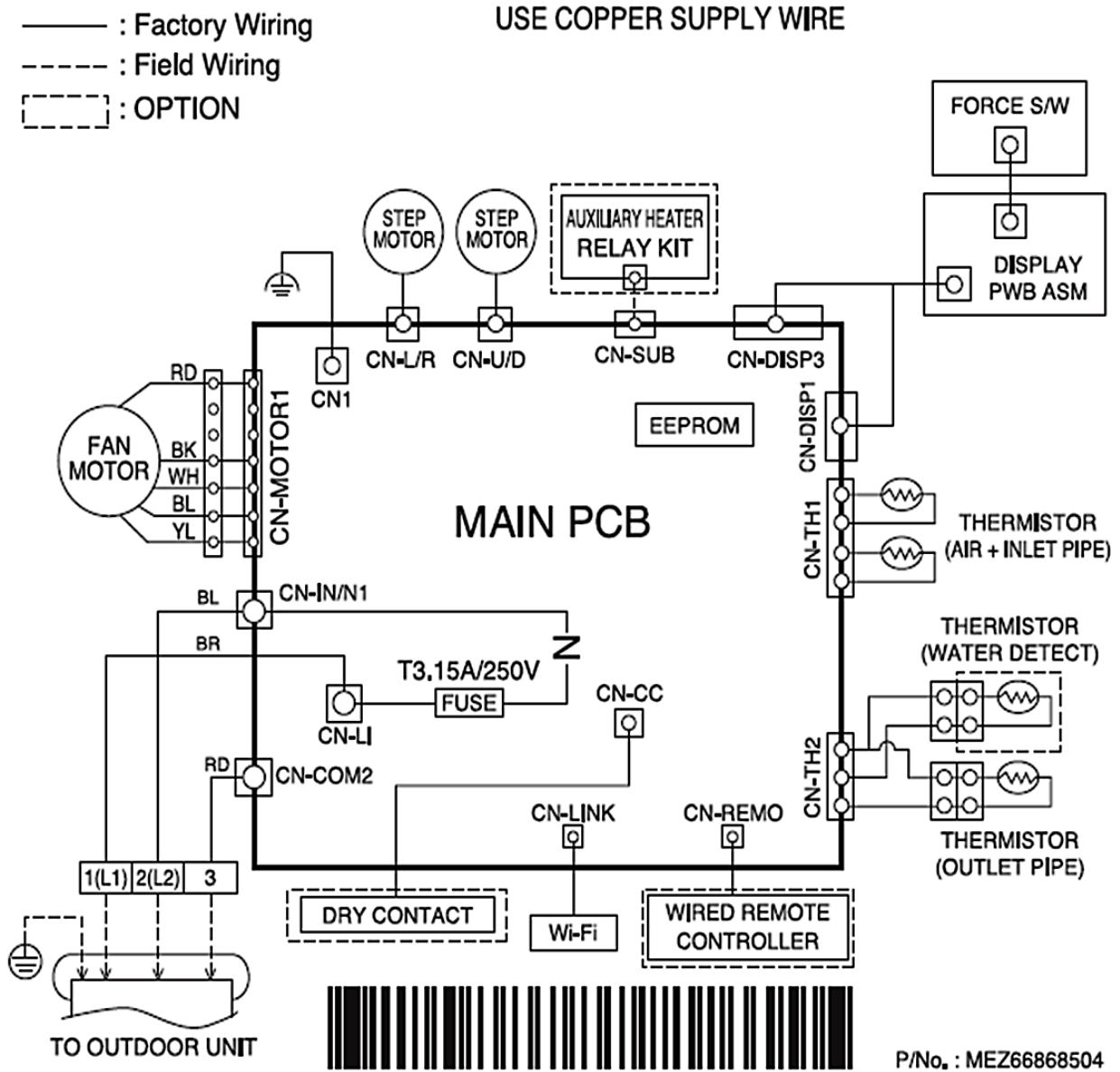
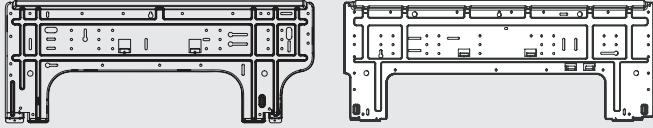
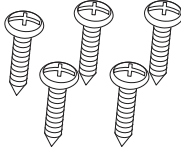
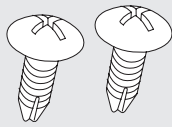

Figure 71: Multi F Standard Wall-Mounted LMN079HVT, LMN159HVT, LMN249HVT Indoor Unit Wiring Diagram.



Multi F and Multi F MAX Indoor Unit Engineering Manual

Factory Supplied Parts

Table 32: Parts Table.

Part	Quantity	Image
Installation Plate	One (1)	 <p>7,000 ~ 15,000 Btu/h Indoor Units 18,000 and 24,000 Btu/h Indoor Units</p>
Type "A" Screws	Five (5)	
Type "B" Screws (M4 x 12L)	Two (2)	
Wireless Controller with Holder AKB74955602	One (1)	

Factory Supplied Materials

- Owner's Manual
- Installation Manual

Required Tools

- Level
- Screwdriver
- Electric drill
- Hole core drill
- Flaring tool set
- Spanner (Half union)
- Thermometer

⚠ WARNING

Installation work must be performed by trained personnel and in accordance with national wiring standards and all local or other applicable codes. Improper installation can result in fire, electric shock, physical injury, or death.

Note:

Read all instructions before installing this product. Become familiar with the unit's components and connections, and the order of installation. Incorrect installation can degrade or prevent proper operation.

STANDARD WALL-MOUNTED INDOOR UNITS

MULTI F
MULTI F MAX

Installation and Best Layout Practices

Selecting the Best Location

Do's

- Place the unit where air circulation will not be blocked.
- Place the unit where drainage can be obtained easily.
- Place the unit where noise prevention is taken into consideration.
- Ensure there is sufficient space from the ceiling and floor.
- Ensure there is sufficient maintenance space.
- Locate the indoor unit where it can be easily connected to the outdoor unit or branch distribution unit.

Don'ts

- Do not install the unit near a heat or steam source, or where considerable amounts of oil, iron powder, or flour are used.
- Do not install the unit where sulfuric acid and flammable or corrosive gases are generated, vented into, or stored.
- Do not install the unit near high-frequency generators.
- Do not install the unit near a doorway.

The unit may be damaged, may malfunction, and / or will not operate as designed if installed in any of the conditions listed.

Figure 72: Minimum Clearance Requirements.

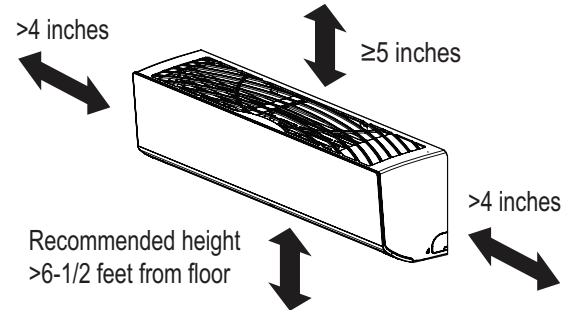

Installing in an Area Exposed to Unconditioned Air

In some installation applications, areas (floors, walls) in some rooms may be exposed to unconditioned air (room may be above or next to an unheated garage or storeroom). To countermeasure:

- Verify that carpet is or will be installed (carpet may increase the temperature by three degrees).
- Add insulation between the floor joists.
- Install radiant heat or another type of heating system to the floor.

Mounting the Installation Plate

The mounting wall should be strong and solid enough to protect the unit from vibration.

- Mount the installation plate on the wall using the Type "A" screws. If mounting the unit on concrete, consider using anchor bolts.
- Always mount the installation plate horizontally. Measure the wall and mark the centerline using thread and a level.

Figure 73: Installation Plate—Side View.

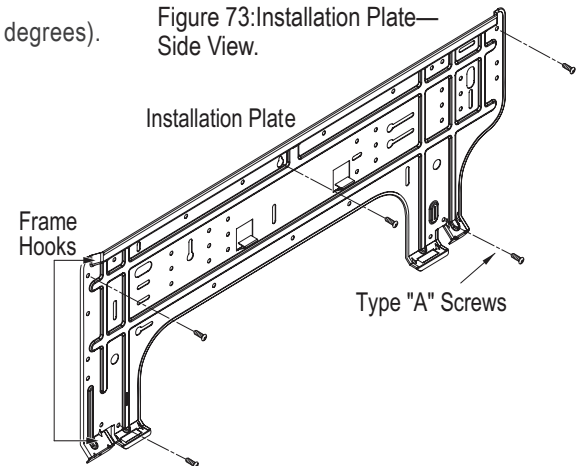

Figure 74: Installation Plate for LMN079HVT, LSN090HSV5, LSN120HSV5, and LMN159HVT Units.

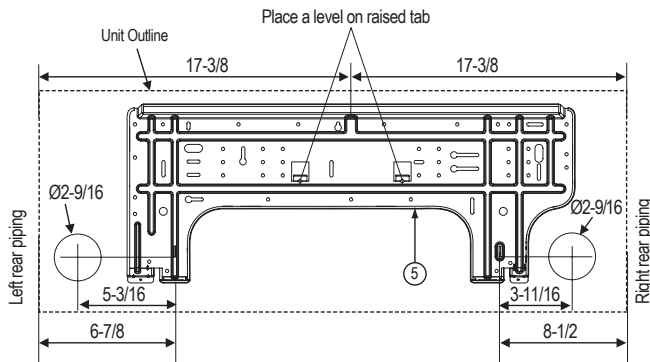
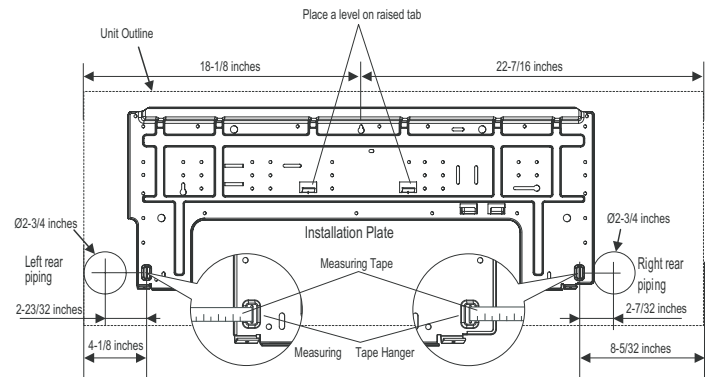

Figure 75: Installation Plate for LSN180HSV5 and LMN249HVT Units.



Note:

If the unit is installed near a body of water, certain components are at risk of being corroded. Appropriate anti-corrosion methods should be taken for the unit and all components.

Preparing for Installation

Prepare the refrigerant piping and drain hose (indoor unit piping) for installation through the wall: press on the top of the tubing clamp and slowly guide the piping / hose down (depending on installation requirements, then to the left or right). Relock the tubing clamp after the piping / hose are released.

Note:

Do not bend the piping / drain hose from side to side; it may damage the components.

Hanging the Indoor Unit Frame

1. Attach the three (3) hooks on the top of the indoor unit to the top edge of the installation plate. Verify the hooks are properly attached to the installation plate by gently shaking the indoor unit from side to side.
2. Unlock the tubing clamp from the indoor unit frame. For easier access between the bottom of the indoor unit and the wall, prop the clamp between the indoor unit frame and installation plate.
3. Remove the screw covers at the bottom of the indoor unit, unscrew the two (2) screws, remove the frame cover, remove the piping connection cover, and position the piping for installation (down, back, left, or right).

Figure 76: Preparing for Installation.

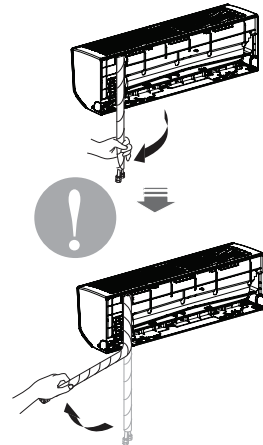

Figure 77: Locking the Indoor Unit onto the Installation Plate.

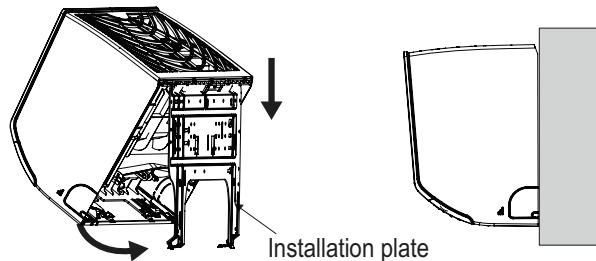

Figure 78: Accessing the Back of the Indoor Unit.

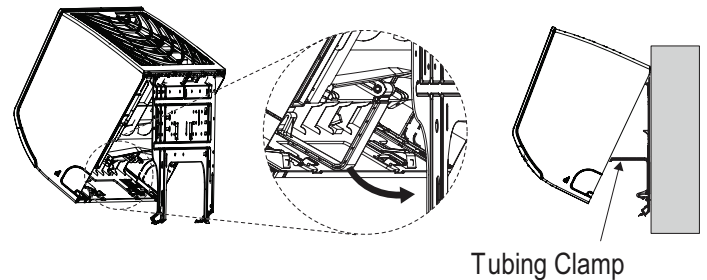

Figure 79: Removing the Frame Cover.

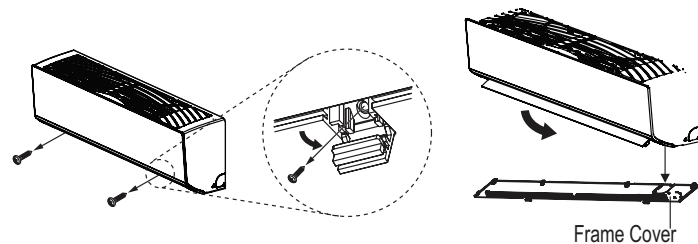

Figure 80: Exterior Back View of Indoor Unit.

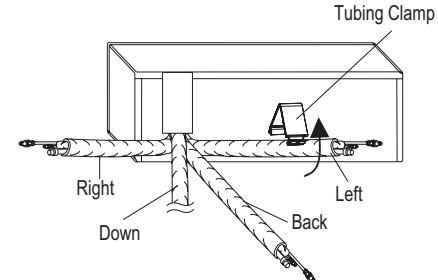

Figure 81: Piping Installed to the Left.

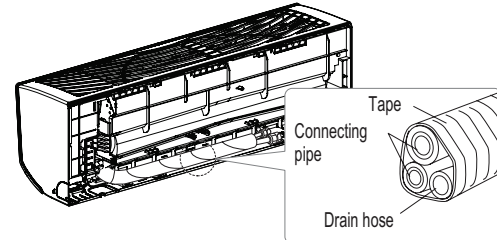
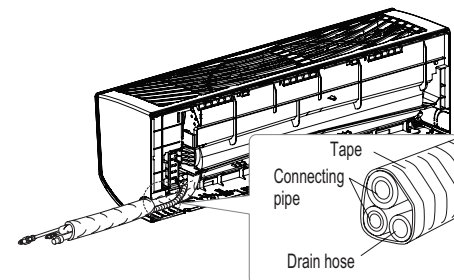

Figure 82: Piping Installed to the Right.



STANDARD WALL-MOUNTED INDOOR UNITS

Installation and Best Layout Practices

MULTI F
MULTI F MAX

Power Wiring / Communications Cable Guidelines

- Follow manufacturer's circuit diagrams in the technical manuals.
- Confirm power source specifications.
- Confirm that the electrical capacity is sufficient.
- Starting current must be maintained ± 10 percent of the rated current marked on the outdoor unit name plate.
- Confirm cable thickness specifications.
- It is recommended that a circuit breaker is installed, especially if conditions could become wet or moist.
- Include a disconnect in the power wiring system, add an air gap contact separation of at least 1/8 inch in each active (phase) conductor.

⚠ WARNING

- Loose wiring may cause unit to malfunction, overheat, and catch fire, resulting in severe injury or death.

Note:

- Terminal screws may become loose during transport. Properly tighten the terminal connections during installation.
- A voltage drop may cause the following problems:
 - Magnetic switch vibration, fuse breaks, or disturbance to the normal function of an overload protection device.
 - Compressor will not receive the proper starting current.

Connect Power Wiring and Communications Cable

1. Insert the power wiring / communications cable from the outdoor unit or branch distribution unit (Multi F MAX systems only) through the bottom of the indoor unit.
2. Connect each wire to its appropriate terminal on the indoor unit control board. Verify that the color and terminal numbers from the outdoor unit or branch distribution unit (Multi F MAX systems only) wiring match the color and terminal numbers on the indoor unit.
3. Secure power wiring/communications cable with cable restraint.

Figure 84: Simplified View of Indoor Unit to Outdoor Unit / Branch Distribution Unit Terminal Connections—LMN079HVT, LSN090HSV5, LSN120HSV5 and LMN159HVT.

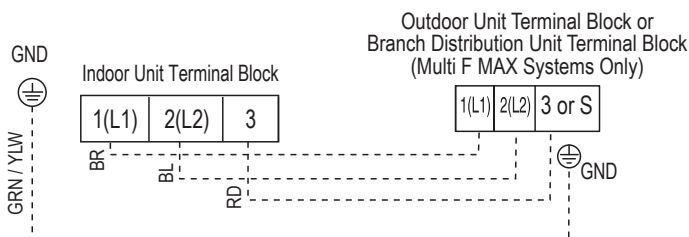

Figure 83: Connecting Power Wiring / Communications Cable.

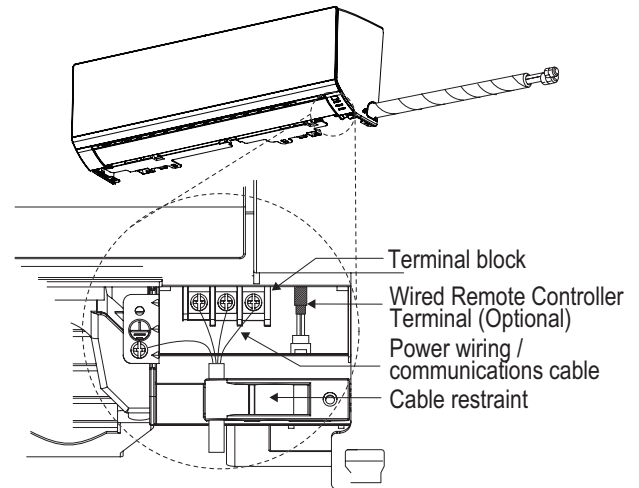
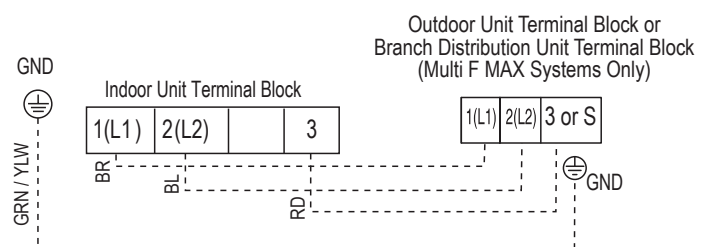

Figure 85: Simplified View of Indoor Unit to Outdoor Unit / Branch Distribution Unit Terminal Connections—LSN180HSV5 and LMN249HVT.



Controller Options

Standard wall-mounted indoor units include a wireless controller (AKB74955602), but optional LG-supplied wired controllers are available.

Wireless Controller

Figure 86:AKB74955602 Wireless Controller.

Table 33: AKB74955602 Wireless Controller Functions.

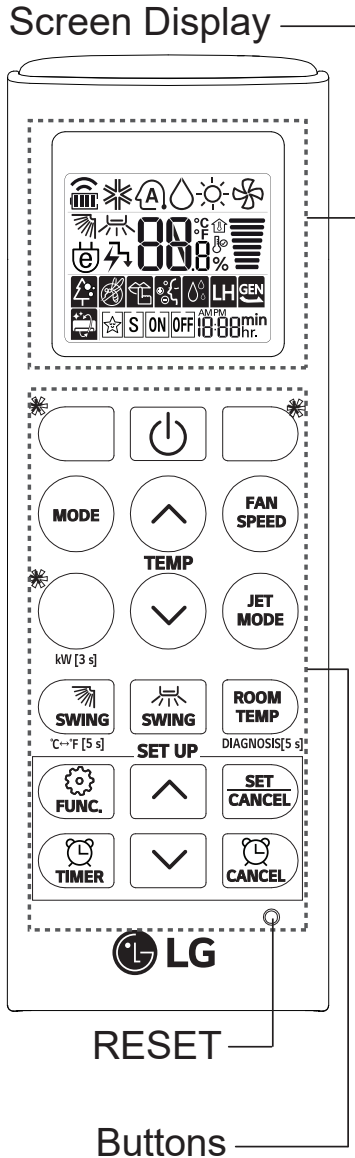

Button	Display Screen	Description
[Icon]	[Icon]	To purify the air by removing particles that enters the indoor unit.
	[Icon]	To reduce noise from outdoor units.
	[Icon]	To keep your skin moisturized by generating ion clusters.
	[Icon]	To lower indoor humidity quickly.
	[Icon]	To maintain a minimum indoor temperature and prevent indoor objects from freezing.
	[Icon]	To fan away a mosquito.
	[Icon]	To remove moisture generated inside the indoor unit.
[Icon]	[Icon]	To make the comfortable sleep environment.
RESET	-	To Initialize the remote control settings.

Button	Display Screen	Description
[Power]	-	To turn on/off the air conditioner.
[Up/Down]	88°	To adjust the desired room temperature in cooling, heating or auto changeover mode.
MODE	[Snowflake]	To select the cooling mode.
	[Flame]	To select the heating mode.
	[Water Drop]	To select the dehumidification mode.
	[Fan]	To select the fan mode.
	[Auto]	To select the auto changeover/auto operation mode.
JET MODE	Po	To change room temperature quickly.
FAN SPEED	[Fan Speed Icon]	To adjust the fan speed.
[Swing]	[Swing Icon]	To adjust the air flow direction vertically or horizontally.
[Timer]	[ON/OFF]	To turn on/off air conditioner automatically at desired time.
SET/CANCEL	-	To set/cancel the special functions and timer.
[Cancel]	-	To cancel the timer settings.
[Up/Down]	-	To adjust time.
*LIGHT OFF	-	To set the brightness of the display on the indoor unit.
ROOM TEMP	[Up Arrow]	To display the room temperature.
°C ↔ °F [5 s]	°C / °F	To change unit between °C and °F.
*ENERGY SAVING	[Energy Saving Icon]	To minimize power consumption.
*COMFORT AIR	[Comfort Air Icon]	To adjust the air flow to deflect wind.
kW[3 s]	-	To set whether or not to display information regarding energy.
*ENERGY CTRL	[Energy Ctrl Icon]	To bring the effect of the power saving.
*COMFORT SLEEP	[Comfort Sleep Icon]	To make the comfortable sleep environment.
DIAGNOSIS [5 s]	-	To conveniently check maintenance information of a product.

STANDARD WALL-MOUNTED INDOOR UNITS

MULTI F
MULTI F MAX

Installation and Best Layout Practices

Wired Controller Connections

Figure 87: Wired Controller Connection on Indoor Unit Terminal Block—LMN079HVT, LSN090HSV5, LSN120HSV5, and LMN159HVT Models.

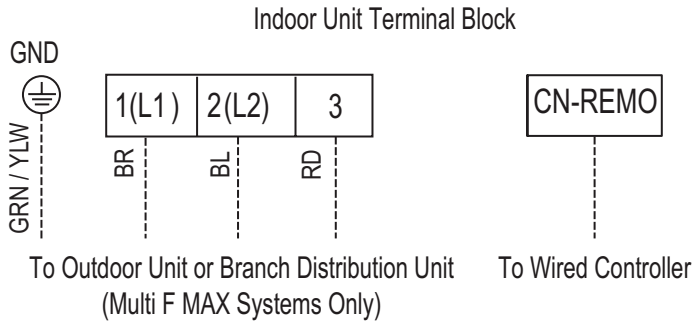
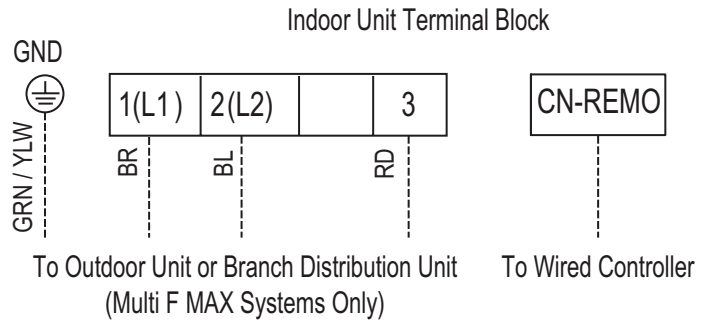

Figure 88: Wired Controller Connection on Indoor Unit Terminal Block—LSN180HSV5 and LMN249HVT Models.



Wired Controller Placement

Wired controllers include a sensor to detect room temperature. To maintain comfort levels in the conditioned space, the wired controller must be installed in a location away from direct sunlight, high humidity, and where it could be directly exposed to cold air. Controller must be installed four (4) to five (5) feet above the floor where its LED display can be read easily, in an area with good air circulation, and where it can detect an average room temperature.

- Do not install the wired controller near or in:
 - Drafts or dead spots behind doors and in corners
 - Hot or cold air from ducts
 - Radiant heat from the sun or appliances
 - Concealed pipes and chimneys
 - An area where temperatures are uncontrolled, such as an outside wall

Figure 89: Proper Location for the Wired Controller.

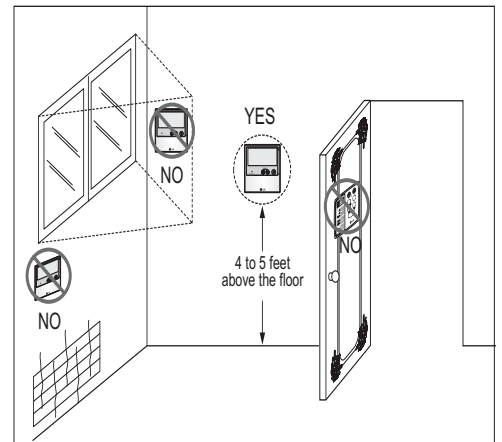

Hanging the Wired Controller

1. The controller wiring / cable can be installed in one of three directions: top, back, or on the right side. If top or right side installation is desired, remove cable guide grooves on the controller, and then position wiring / cable on applicable side.
2. Choose and mark the area of installation. Use the provided parts and screw the wall plate into place. Install the controller wall plate to fit the electrical box if one is present. Ensure that no gaps exist between the wall plate and the wall itself.
3. Arrange wiring / cables so as not to interfere with the controller circuitry. Position the wired controller on the wall plate. Snap into place by pressing the bottom part of the wired controller onto the wall plate. Make sure that no gaps exist between the wired controller and the wall plate on all sides.
4. To remove wired controller from the wall plate, insert a screwdriver into the two holes at the bottom. Twist screwdriver to release controller. Do not damage the controller components when removing.

Figure 91: Removing the Cable Guide Grooves.

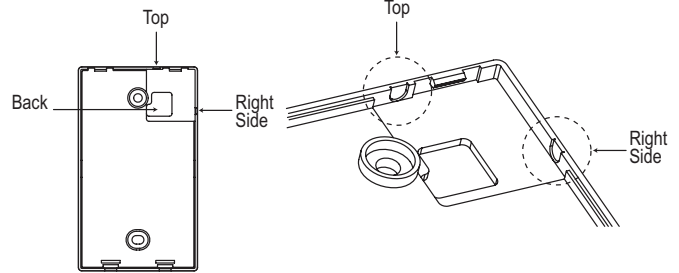

Figure 92: Attaching the Wall Plate.

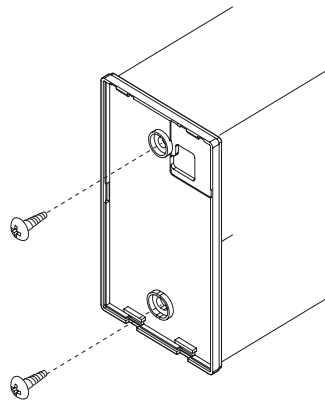
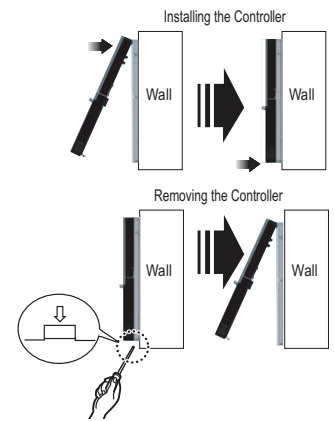

Figure 93: Installing / Removing the Controller.



Assigning the Thermistor for Temperature Detection

Each indoor unit includes a return air thermistor assigned to sense the temperature. If a wired controller is installed, there is a choice of sensing temperature with either the indoor unit return air thermistor or the thermistor in the wired controller. It is also an option to set both thermistors to sense temperature so that indoor unit bases its operation on the first thermistor to reach the designated temperature differential. For applicable indoor units, an optional Remote Temperature Sensor can be used in lieu of the return air thermistor—either alone or in conjunction with a wired controller thermistor as previously described.

Finalizing Indoor Unit Installation

1. Move the tubing clamp to its original position.
2. Ensure the three (3) hooks are properly attached to the installation plate by gently shaking the indoor unit from side to side.
3. Press the bottom left and right sides of the indoor unit against the installation plate until the hooks click firmly into their slots.
4. Using two (2) Type “C” screws, secure the bottom of the indoor unit to the installation plate.
5. Remove the two (2) tabs from the filter.
6. Replace the frame cover.

Figure 90: Attach Bottom of Indoor Unit to Installation Plate.

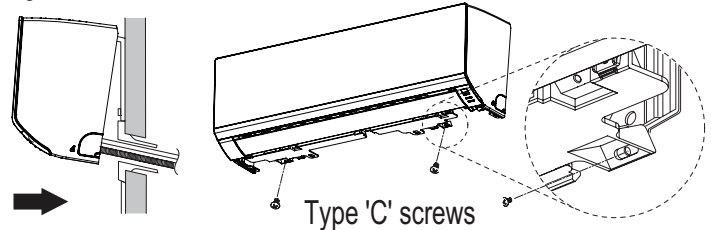
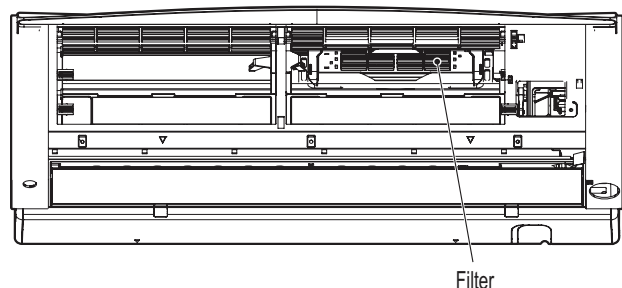

Figure 94: Removing the Filter Tabs.



CEILING-CONCEALED DUCT (LOW STATIC) INDOOR UNIT DATA

“Mechanical Specifications” on page 73

“General Data / Specifications” on page 74

“Dimensions” on page 75

“Cooling Capacity Table” on page 76

“Heating Capacity Table” on page 78

“External Static Pressure” on page 79

“Acoustic Data” on page 80

“Refrigerant Flow Diagram” on page 81

“Wiring Diagram” on page 83

“Factory Supplied Parts and Materials” on page 84

“Installation and Best Layout Practices” on page 85

Ceiling-Concealed Duct (Low Static) Indoor Unit

General

All LG indoor units are factory assembled, wired, piped, and provided with a control circuit board, fan, and motor. Ceiling-Concealed Duct (Low Static) units have a sound rating no higher than 36 dB(A) as tested per KSA0701 ISO Standard 3745, and are designed for low-static pressure up to 0.20"WG.

Coil

Indoor unit coils are factory built and are comprised of aluminum fins mechanically bonded to copper tubing. Each unit has two rows of coils, which are pressure tested at the factory. Each unit is provided with a factory installed condensate drain pan below the coil.

Refrigerant System

System is designed for use with R410A refrigerant. The refrigeration circuit is pressure-tested at the factory and shipped with a holding charge of helium gas. Refrigerant pipe connections are 45° flare, and all refrigerant lines from the outdoor unit to the indoor units must be field insulated.

Electrical

Each indoor unit is designed to operate using 208–230/60/1 power with voltage variances of ±10%.

Casing

The case has a low profile design with a maximum height of 7.5 inches designed to mount fully concealed above a finished ceiling in as little as 8 inches vertical space. Casing is manufactured of galvanized steel plate, and provided with hanger brackets designed to support the weight on four corners. Unit has a front horizontal supply air discharge outlet, and one rear horizontal return air inlet; unit is also field-convertible for a rear bottom return.

Fan Assembly and Control

The units have at least two direct-drive, Sirocco fans made of high strength ABS HT-700 polymeric resin that are statically and dynamically balanced. The fans are mounted on a common brushless digitally controlled (BLDC) motor with permanently lubricated and sealed ball bearings. The fan / motor assembly is mounted on vibration-attenuating rubber grommets. Fan speed is controlled using a microprocessor-based direct digital control algorithm. The indoor fan has Low, Med, High, and Auto settings for Cooling mode; and

Figure 95: Ceiling-Concealed Duct (Low Static) Indoor Unit.



has Low, Med, High, and Auto settings for Heating mode. Each of the settings can be field-adjusted from the factory setting (RPM / ESP). The Auto setting adjusts the fan speed based on the difference between the controller set-point and space temperature.

Air Filter

Return air is filtered with a factory-supplied, removable, washable filter accessible from the rear of the indoor unit.

Microprocessor Control

The unit is provided with an integrated control panel to communicate with the outdoor unit. All unit operation parameters are stored in non-volatile memory residing on the unit microprocessor. The microprocessor controls space temperature through using the value provided by the temperature sensor within the indoor unit. The microprocessor control will activate indoor unit operation when the indoor room temperature falls below or rises above a setpoint temperature, at which point, a signal is sent to the outdoor unit to begin the appropriate mode. The microprocessor will also provide self-diagnostics and auto restart functions. A field-supplied four-wire power / communications cable must be installed to connect the indoor unit(s) to the outdoor unit.

Controls

The indoor unit is supplied with an LG wired controller. Communication between the indoor units and the outdoor unit is accomplished through 18 AWG, four-core, stranded and shielded power / communication cable.

Condensate Lift/Pump

The indoor unit is provided with an externally mounted, factory installed and wired condensate lift/pump capable of providing a minimum 27.5 inch lift from the bottom surface of the unit. Drain pump has a safety switch to shut off the indoor unit if the condensate rises too high in the drain pan.

Features

- Inverter (Variable speed fan)
- External mounted drain pump
- Control lock function
- Auto operation
- Auto restart operation
- Dehumidification function
- Two thermistor control
- External static pressure control
- Self-diagnostics function
- Group control
- Wired thermostat included

DUCT (LOW STATIC) INDOOR UNITS

General Data / Specifications

MULTI F
MULTI F MAX

Table 34: Multi F Ceiling-Concealed Low-Static Ducted Indoor Unit General Data.

Model Name	LDN097HV4	LDN127HV4	LMDN186HV
Nominal Cooling Capacity (Btu/h) ¹	9,000	12,000	18,000
Nominal Heating Capacity (Btu/h) ¹	10,400	13,800	20,800
<i>Operating Range</i>			
Cooling (°F WB)	57-77		
Heating (°F DB)	59-81		
Fan			
Type	Sirocco		
Motor Output (W) x Qty.	19 x 1	5 x 1, 19 x 1	
Motor/Drive	Brushless Digitally Controlled / Direct		
Airflow Rate CFM (H/M/L)	318 / 247 / 194	353 / 300 / 247	530 / 441 / 353
Factory Set External Static Pressure (in. wg)	0.10		
Max. External Static Pressure (in. wg)	0.20		
<i>Unit Data</i>			
Refrigerant Type ²	R410A		
Refrigerant Control	EEV		
Power Supply V, Ø, Hz ³	208-230, 1, 60		
Rated Amps (A)	0.40	0.80	
Sound Pressure Level ±3 dB(A) (H/M/L) ⁴	30 / 26 / 23	31 / 28 / 27	36 / 34 / 31
Dimensions (W x H x D, in.)	27-9/16 x 7-15/32 x 27-9/16	35-7/16 x 7-15/32 x 27-9/16	
Net Unit Weight (lbs.)	39	51	
Shipping Weight (lbs.)	46	60	57
Power Wiring / Communications Cable (No. x AWG) ⁵	4 x 18		
Heat Exchanger (Row x Column x Fin / inch) x Number	(2 x 11 x 14) x 1	(2 x 11 x 18) x 1	
<i>Piping</i>			
Liquid (in.)	1/4		
Vapor (in.)	3/8		1/2
Drain O.D. / I.D. (in.)	1-1/4, 1		

¹Nominal capacity is rated 0 ft. above sea level with corresponding refrigerant piping length in accordance with standard length of each outdoor unit and a 0 ft. level difference between outdoor and indoor units. All capacities are net with a combination ratio between 95 – 105%.

Nominal cooling capacity rating obtained with air entering the indoor unit at 80°F dry bulb (DB) and 67°F wet bulb (WB) and outdoor ambient conditions of 95°F dry bulb (DB) and 75°F wet bulb (WB).
Nominal heating capacity rating obtained with air entering the indoor unit at 70°F dry bulb (DB) and 60°F wet bulb (WB) and outdoor ambient conditions of 47°F dry bulb (DB) and 43°F wet bulb (WB).

²This unit comes with a dry helium charge.

³Acceptable operating voltage: 187V-253V.

⁴Sound pressure levels are tested in an anechoic chamber under ISO Standard 3745 and are the same in both cooling and heating mode. These values can increase due to ambient conditions during operation.

⁵All power wiring / communications cable to the IDUs be minimum 18 AWG, 4-conductor, stranded, shielded or unshielded (if shielded, must be grounded to chassis at ODU only) and must comply with applicable local and national codes.

Figure 96: LDN097HV4, LDN127HV4, and LMDN186HV Dimensions.

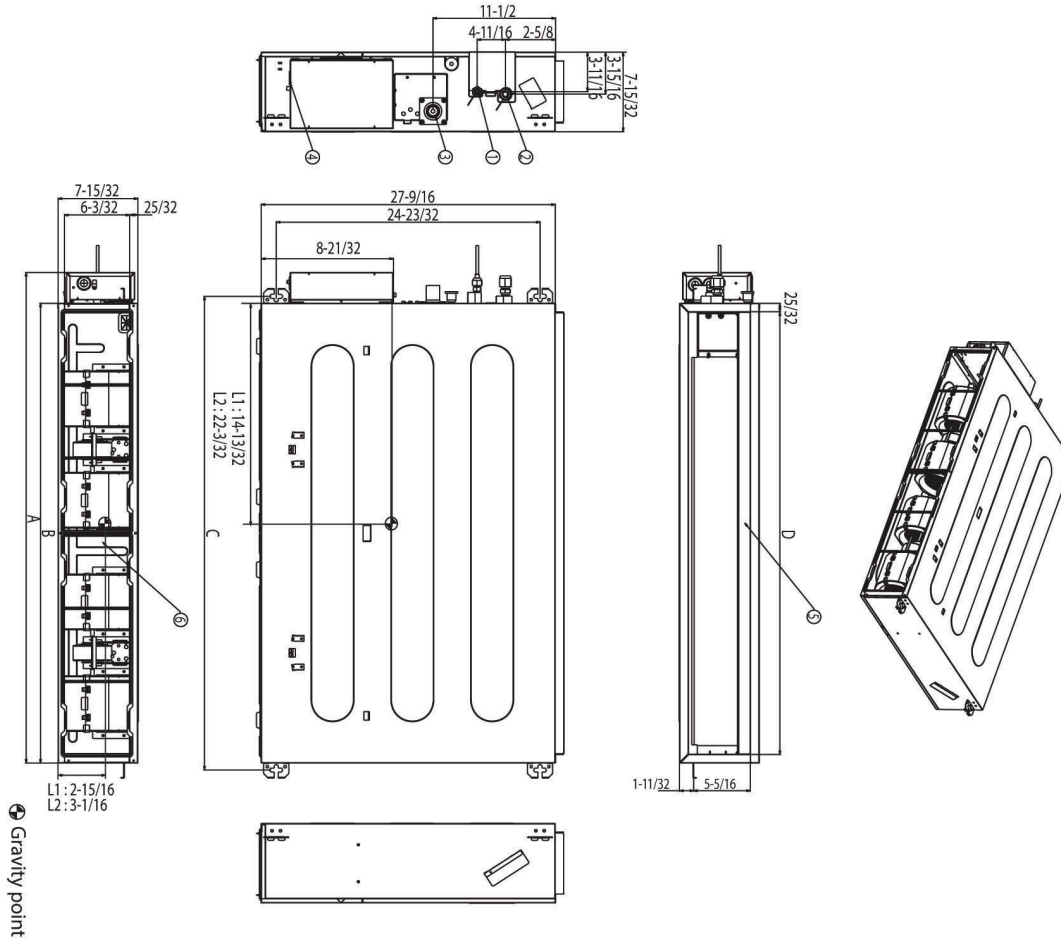

Ceiling-Concealed Duct (Low Static)

Number	Name	Description
1	Liquid pipe connection	
2	Gas pipe connection	
3	Drain pipe connection	
4	Power supply connection	
5	Air discharge	
6	Air suction	

(unit: inch)

Model Number	A	B	C	D
LDN097HV4	30-15/32	27-9/16	28-27/32	25-31/32
LDN127HV4 LMDN186HV	38-11/32	35-7/16	36-23/32	33-27/32

(unit: inch)

DUCT (LOW STATIC) INDOOR UNITS

Cooling Capacity Table

MULTI F
MULTI F MAX

Table 35: Multi F Ceiling-Concealed Duct (Low Static) Indoor Units Cooling Capacity Table.

Model No. / Nominal Capacity of Indoor Unit (Btu/h)	Outdoor Air Temp. (°F DB)	Indoor Air Temp. °F DB / °F WB											
		68 / 57		73 / 61		77 / 64		80 / 67		86 / 72		90 / 75	
		TC	SHC	TC	SHC	TC	SHC	TC	SHC	TC	SHC	TC	SHC
LDN097HV4 9,000	14	8.82	7.55	9.37	7.98	9.92	7.72	10.31	7.89	11.01	7.95	11.56	8.10
	20	8.82	7.61	9.36	8.04	9.91	7.78	10.31	7.95	11.01	8.01	11.55	8.17
	25	8.81	7.67	9.36	8.10	9.90	7.84	10.30	8.01	11.00	8.08	11.54	8.23
	30	8.80	7.73	9.35	8.16	9.90	7.90	10.29	8.07	10.99	8.14	11.54	8.29
	35	8.80	7.79	9.34	8.22	9.89	7.96	10.28	8.13	10.98	8.20	11.53	8.36
	40	8.79	7.84	9.33	8.29	9.88	8.02	10.27	8.19	10.97	8.26	11.52	8.42
	45	8.78	7.90	9.33	8.35	9.87	8.08	10.27	8.25	10.96	8.32	11.51	8.48
	50	8.78	7.96	9.32	8.41	9.87	8.14	10.26	8.31	10.96	8.38	11.50	8.54
	55	8.77	8.02	9.31	8.47	9.86	8.20	10.25	8.38	10.95	8.45	11.49	8.61
	60	8.76	8.08	9.31	8.53	9.85	8.26	10.24	8.44	10.94	8.51	11.48	8.67
	65	8.76	8.14	9.30	8.59	9.84	8.32	10.24	8.50	10.93	8.57	11.47	8.73
	70	8.75	8.19	9.29	8.66	9.84	8.38	10.23	8.56	10.92	8.63	11.47	8.79
	75	8.54	8.06	9.08	8.52	9.62	8.26	10.01	8.44	10.71	8.53	11.25	8.69
	80	8.33	7.92	8.87	8.39	9.41	8.14	9.80	8.33	10.49	8.42	11.03	8.59
	85	8.12	7.78	8.66	8.25	9.20	8.02	9.59	8.20	10.28	8.30	10.82	8.48
	90	7.91	7.63	8.45	8.10	8.99	7.89	9.37	8.08	10.06	8.19	10.60	8.37
	95	7.68	7.55	8.22	8.03	8.75	7.83	9.00	7.90	9.83	8.14	10.36	8.34
	100	7.50	7.35	8.03	7.83	8.57	7.64	8.88	7.78	9.64	7.97	10.17	8.16
105	7.31	7.15	7.84	7.63	8.38	7.45	8.77	7.66	9.45	7.79	9.99	7.99	
110	7.12	6.90	7.66	7.38	8.19	7.22	8.58	7.43	9.26	7.57	9.80	7.77	
115	6.94	6.69	7.47	7.17	8.01	7.03	8.39	7.24	9.08	7.39	9.61	7.60	
118	6.82	6.65	7.36	7.13	7.89	7.00	8.28	7.21	8.96	7.37	9.50	7.58	
122	6.79	6.63	7.32	7.11	7.86	6.98	8.24	7.19	8.93	7.36	9.46	7.57	
LDN127HV4 12,000	14	11.76	9.94	12.49	10.50	13.22	10.17	13.75	10.38	14.69	10.47	15.42	10.67
	20	11.75	10.02	12.48	10.58	13.21	10.25	13.74	10.46	14.67	10.55	15.40	10.75
	25	11.75	10.09	12.48	10.66	13.20	10.33	13.73	10.54	14.66	10.63	15.39	10.83
	30	11.74	10.17	12.47	10.75	13.19	10.40	13.72	10.62	14.65	10.71	15.38	10.92
	35	11.73	10.25	12.46	10.83	13.18	10.48	13.71	10.70	14.64	10.79	15.37	11.00
	40	11.72	10.33	12.45	10.91	13.17	10.56	13.70	10.79	14.63	10.88	15.36	11.08
	45	11.71	10.40	12.44	10.99	13.16	10.64	13.69	10.87	14.62	10.96	15.35	11.16
	50	11.70	10.48	12.43	11.07	13.15	10.72	13.68	10.95	14.61	11.04	15.33	11.25
	55	11.69	10.56	12.42	11.15	13.14	10.80	13.67	11.03	14.60	11.12	15.32	11.33
	60	11.68	10.63	12.41	11.23	13.13	10.88	13.66	11.11	14.59	11.20	15.31	11.41
	65	11.67	10.71	12.40	11.31	13.12	10.96	13.65	11.19	14.57	11.28	15.30	11.49
	70	11.66	10.79	12.39	11.40	13.11	11.03	13.64	11.27	14.56	11.36	15.29	11.58
	75	11.38	10.61	12.11	11.22	12.83	10.88	13.35	11.12	14.27	11.22	15.00	11.45
	80	11.10	10.43	11.82	11.05	12.55	10.72	13.07	10.96	13.99	11.08	14.71	11.31
	85	10.83	10.24	11.54	10.86	12.26	10.55	12.78	10.80	13.70	10.93	14.42	11.17
	90	10.55	10.04	11.26	10.67	11.98	10.38	12.50	10.63	13.42	10.78	14.13	11.02
	95	10.25	9.94	10.96	10.57	11.67	10.30	12.00	10.40	13.10	10.72	13.81	10.97
	100	10.00	9.67	10.71	10.31	11.42	10.06	11.84	10.24	12.85	10.49	13.56	10.75
105	9.75	9.41	10.46	10.04	11.17	9.81	11.69	10.08	12.60	10.26	13.31	10.52	
110	9.50	9.09	10.21	9.72	10.92	9.51	11.44	9.78	12.35	9.97	13.07	10.24	
115	9.25	8.81	9.96	9.44	10.67	9.26	11.19	9.53	12.10	9.73	12.82	10.00	
118	9.10	8.75	9.81	9.39	10.52	9.21	11.04	9.49	11.95	9.70	12.67	9.98	
122	9.05	8.73	9.76	9.37	10.48	9.19	10.99	9.47	11.90	9.69	12.62	9.97	

TC = Total Capacity (kBtu/h).

SHC: Sensible Heat Capacity (kBtu/h).

Nominal capacity as rated 0 ft. above sea level and a 0 ft. level difference between outdoor and indoor units. Corresponding refrigerant piping length is accordance with standard length of each outdoor unit.

Nominal cooling capacity rating obtained with air entering the indoor unit at 80°F dry bulb (DB) and 67°F wet bulb (WB), and outdoor ambient conditions of 95°F dry bulb (DB) and 75°F wet bulb (WB).

The shaded table columns and rows indicate reference data. When operating at this temperature, these values can be different if the system is not running consistently.

Multi F and Multi F MAX Indoor Unit Engineering Manual

Table 36: Multi F Ceiling-Concealed Duct (Low Static) Indoor Units Cooling Capacity Table (continued).

Model No. / Nominal Capacity of Indoor Unit (Btu/h)	Outdoor Air Temp. (°F DB)	Indoor Air Temp. °F DB / °F WB											
		68 / 57		73 / 61		77 / 64		80 / 67		86 / 72		90 / 75	
		TC	SHC	TC	SHC	TC	SHC	TC	SHC	TC	SHC	TC	SHC
LMDN186HV 18,000	14	17.65	13.09	18.74	13.83	19.84	13.39	20.63	13.67	22.03	13.79	23.12	14.05
	20	17.63	13.20	18.73	13.94	19.82	13.50	20.61	13.78	22.01	13.90	23.11	14.16
	25	17.62	13.30	18.71	14.05	19.81	13.60	20.60	13.89	22.00	14.01	23.09	14.27
	30	17.60	13.40	18.70	14.16	19.79	13.71	20.58	13.99	21.98	14.11	23.07	14.38
	35	17.59	13.50	18.68	14.26	19.78	13.81	20.57	14.10	21.96	14.22	23.05	14.49
	40	17.58	13.60	18.67	14.37	19.76	13.91	20.55	14.21	21.94	14.33	23.04	14.60
	45	17.56	13.71	18.66	14.48	19.75	14.02	20.53	14.31	21.93	14.43	23.02	14.71
	50	17.55	13.81	18.64	14.58	19.73	14.12	20.52	14.42	21.91	14.54	23.00	14.82
	55	17.54	13.91	18.63	14.69	19.72	14.23	20.50	14.52	21.89	14.65	22.98	14.92
	60	17.52	14.01	18.61	14.80	19.70	14.33	20.49	14.63	21.88	14.75	22.97	15.03
	65	17.51	14.11	18.60	14.90	19.69	14.43	20.47	14.74	21.86	14.86	22.95	15.14
	70	17.50	14.21	18.58	15.01	19.67	14.53	20.46	14.84	21.84	14.97	22.93	15.25
	75	17.08	13.98	18.16	14.78	19.24	14.33	20.03	14.64	21.41	14.78	22.50	15.08
	80	16.66	13.74	17.74	14.55	18.82	14.12	19.60	14.44	20.98	14.60	22.06	14.90
	85	16.24	13.49	17.32	14.30	18.40	13.90	19.17	14.23	20.55	14.40	21.63	14.71
	90	15.82	13.23	16.90	14.06	17.97	13.68	18.75	14.01	20.12	14.20	21.20	14.52
	95	15.37	13.09	16.44	13.93	17.51	13.57	18.00	13.70	19.65	14.12	20.72	14.46
	100	14.99	12.74	16.06	13.58	17.13	13.25	17.77	13.49	19.28	13.82	20.35	14.16
105	14.62	12.39	15.69	13.23	16.76	12.93	17.53	13.28	18.90	13.52	19.97	13.86	
110	14.24	11.97	15.32	12.80	16.39	12.53	17.16	12.88	18.53	13.13	19.60	13.48	
115	13.87	11.61	14.94	12.44	16.01	12.19	16.79	12.55	18.15	12.82	19.22	13.18	
118	13.65	11.53	14.72	12.36	15.79	12.13	16.56	12.50	17.93	12.77	19.00	13.14	
122	13.57	11.50	14.64	12.34	15.71	12.11	16.49	12.48	17.85	12.76	18.92	13.13	

TC = Total Capacity (kBtu/h).

SHC: Sensible Heat Capacity (kBtu/h).

Nominal capacity as rated 0 ft. above sea level and a 0 ft. level difference between outdoor and indoor units. Corresponding refrigerant piping length is accordance with standard length of each outdoor unit.

Nominal cooling capacity rating obtained with air entering the indoor unit at 80°F dry bulb (DB) and 67°F wet bulb (WB), and outdoor ambient conditions of 95°F dry bulb (DB) and 75°F wet bulb (WB).

The shaded table columns and rows indicate reference data. When operating at this temperature, these values can be different if the system is not running consistently.

DUCT (LOW STATIC) INDOOR UNITS

Heating Capacity Table

MULTI F
MULTI F MAX

Table 37: Multi F Ceiling-Concealed Duct (Low Static) Indoor Units Heating Capacity Table.

Model No. / Nominal Capacity of Indoor Unit (Btu/h)	Outdoor Air Temp.		Indoor Air Temp. °F DB					
	°F DB	°F WB	61	64	68	70	72	75
			TC	TC	TC	TC	TC	TC
LDN097HV4 9,000	0	-0.4	5.35	5.28	5.23	5.20	5.12	4.90
	5	4.5	6.03	5.95	5.90	5.88	5.80	5.58
	10	9	6.71	6.63	6.58	6.56	6.48	6.26
	17	15	7.61	7.54	7.49	7.46	7.39	7.14
	20	19	7.95	7.88	7.83	7.80	7.72	7.46
	25	23	8.52	8.44	8.39	8.37	8.29	7.99
	30	28	9.01	8.93	8.88	8.86	8.78	8.52
	35	32	9.50	9.42	9.37	9.34	9.27	9.04
	40	36	9.94	9.86	9.81	9.78	9.71	9.48
	45	41	10.37	10.30	10.25	10.22	10.15	9.92
	47	43	10.55	10.48	10.43	10.40	10.32	10.10
	50	46	10.72	10.64	10.59	10.57	10.49	10.24
	55	51	11.00	10.93	10.88	10.85	10.78	10.48
	60	56	11.00	10.93	10.88	10.85	10.78	10.52
	63	59	11.00	10.93	10.88	10.85	10.78	10.55
68	64	11.00	10.93	10.88	10.85	10.78	10.60	
LDN127HV4 12,000	0	-0.4	7.10	7.00	6.93	6.90	6.80	6.50
	5	4.5	8.00	7.90	7.83	7.80	7.70	7.40
	10	9	8.90	8.80	8.73	8.70	8.60	8.30
	17	15	10.10	10.00	9.93	9.90	9.80	9.48
	20	19	10.55	10.45	10.38	10.35	10.25	9.90
	25	23	11.30	11.20	11.13	11.10	11.00	10.60
	30	28	11.95	11.85	11.78	11.75	11.65	11.30
	35	32	12.60	12.50	12.43	12.40	12.30	12.00
	40	36	13.18	13.08	13.02	12.98	12.88	12.58
	45	41	13.77	13.67	13.60	13.57	13.47	13.17
	47	43	14.00	13.90	13.83	13.80	13.70	13.40
	50	46	14.23	14.13	14.06	14.03	13.93	13.59
	55	51	14.60	14.50	14.43	14.40	14.30	13.90
	60	56	14.60	14.50	14.43	14.40	14.30	13.96
	63	59	14.60	14.50	14.43	14.40	14.30	14.00
68	64	14.60	14.50	14.43	14.40	14.30	14.06	
LMDN186HV 18,000	0	-0.4	10.70	10.55	10.45	10.40	10.25	9.80
	5	4.5	12.06	11.91	11.81	11.76	11.61	11.15
	10	9	13.41	13.26	13.16	13.11	12.96	12.51
	17	15	15.22	15.07	14.97	14.92	14.77	14.29
	20	19	15.90	15.75	15.65	15.60	15.45	14.92
	25	23	17.03	16.88	16.78	16.73	16.58	15.98
	30	28	18.01	17.86	17.76	17.71	17.56	17.03
	35	32	18.99	18.84	18.74	18.69	18.54	18.09
	40	36	19.87	19.72	19.62	19.57	19.42	18.97
	45	41	20.75	20.60	20.50	20.45	20.30	19.85
	47	43	21.10	20.95	20.85	20.80	20.65	20.20
	50	46	21.44	21.29	21.19	21.14	20.99	20.48
	55	51	22.01	21.86	21.75	21.70	21.55	20.95
	60	56	22.01	21.86	21.75	21.70	21.55	21.04
	63	59	22.01	21.86	21.75	21.70	21.55	21.10
68	64	22.01	21.86	21.75	21.70	21.55	21.20	

TC = Total Capacity (kBtu/h).

Nominal capacity as rated 0 ft. above sea level and a 0 ft. level difference between outdoor and indoor units. Corresponding refrigerant piping length is accordance with standard length of each outdoor unit. Nominal heating capacity rating obtained with air entering the indoor unit at 70°F dry bulb (DB) and 60°F wet bulb (WB), and outdoor ambient conditions of 47°F dry bulb (DB) and 43°F wet bulb (WB).

Multi F and Multi F MAX Indoor Unit Engineering Manual

Table 38: Multi F Ceiling-Concealed Duct (Low Static) External Static Pressure Setting Values Table.

Static Pressure (in. wg)			0.0	0.04	0.08	0.12	0.16	0.20
Model No. / Nominal Capacity of Indoor Unit (Btu/h)	Airflow Rate / CFM		Setting Value					
	LDN097HV4 9,000	High	318	98	103	108	116	123
Mid		247	82	88	94	102	110	118
Low		194	69	76	83	91	99	109
LDN127HV4 12,000	High	353	95	99	104	109	116	124
	Mid	300	86	91	96	101	108	116
	Low	247	78	82	87	93	100	108
LMDN186HV 18,000	High	530	123	125	129	134	141	145
	Mid	441	109	112	117	123	129	136
	Low	353	95	99	104	109	116	124

Note:

- To get the desired air flow and external static pressure combination, use the setting value from the table. Using a setting value other than that listed in the table will not provide the desired combination.
- Table data is based at 230V. Air flow rate varies according to voltage fluctuation.

DUCT (LOW STATIC) INDOOR UNITS

Acoustic Data

MULTI F
MULTI F MAX

Figure 97: Sound Pressure Level Measurement Location.

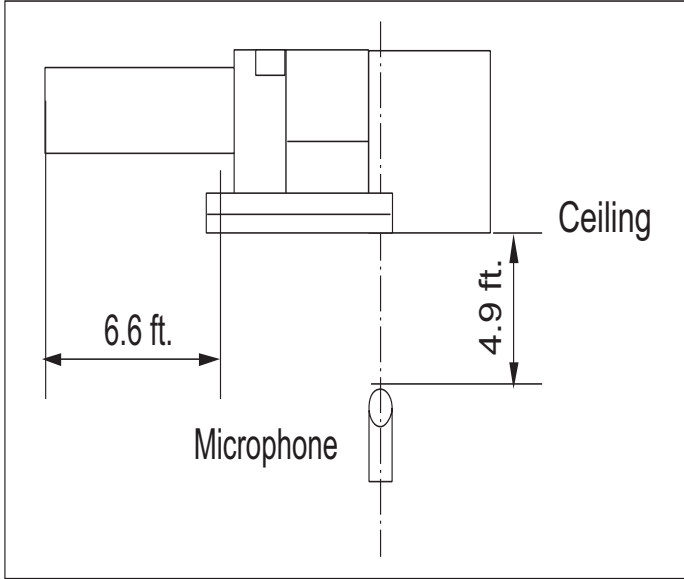

- Measurements taken with no attenuation and units operating at full load normal operating condition.
- Sound level will vary depending on a range of factors such as construction (acoustic absorption coefficient) of particular area in which the equipment is installed.
- Sound power levels are measured in dB(A)±3.
- Tested in anechoic chamber per ISO Standard 3745.

Table 39: Sound Pressure Levels (dB[A]).

Model No.	Sound Pressure Levels (dB[A]) (Cooling and Heating)		
	High Fan Speed	Medium Fan Speed	Low Fan Speed
LDN097HV4	30	26	23
LDN127HV4	31	28	27
LMDN186HV	36	34	31

Figure 98: Sound Pressure Level Diagrams.

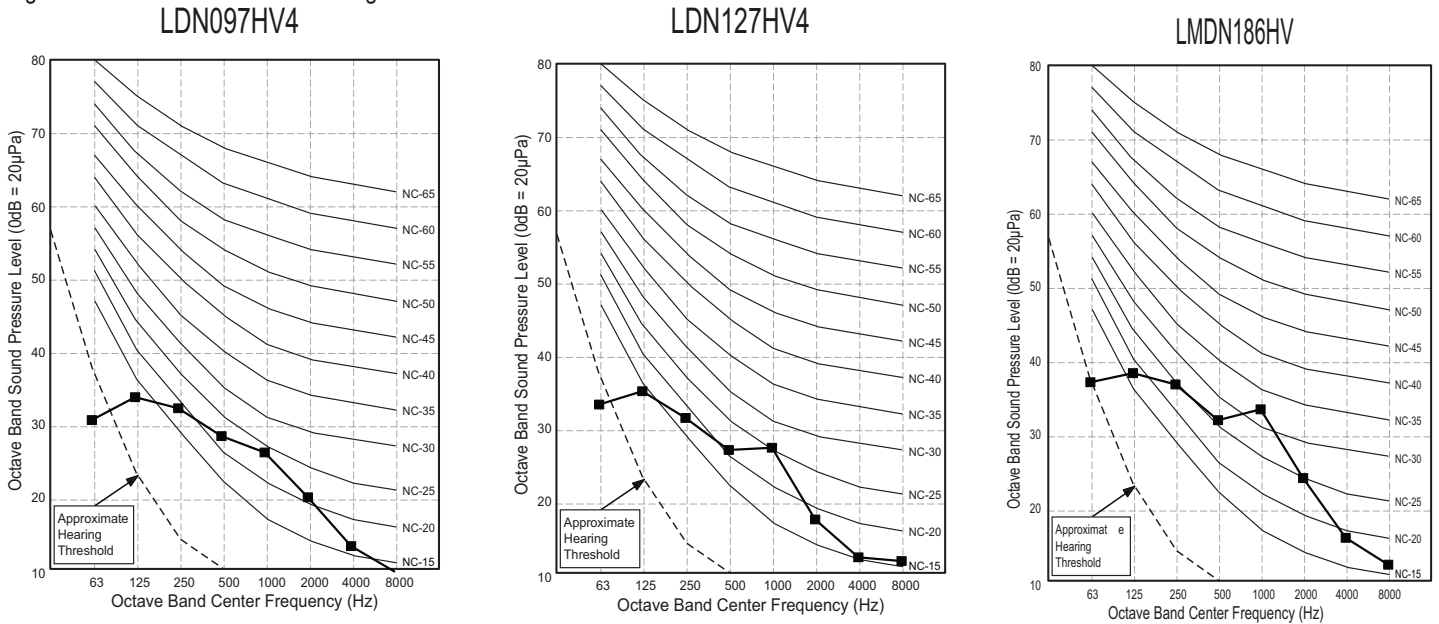
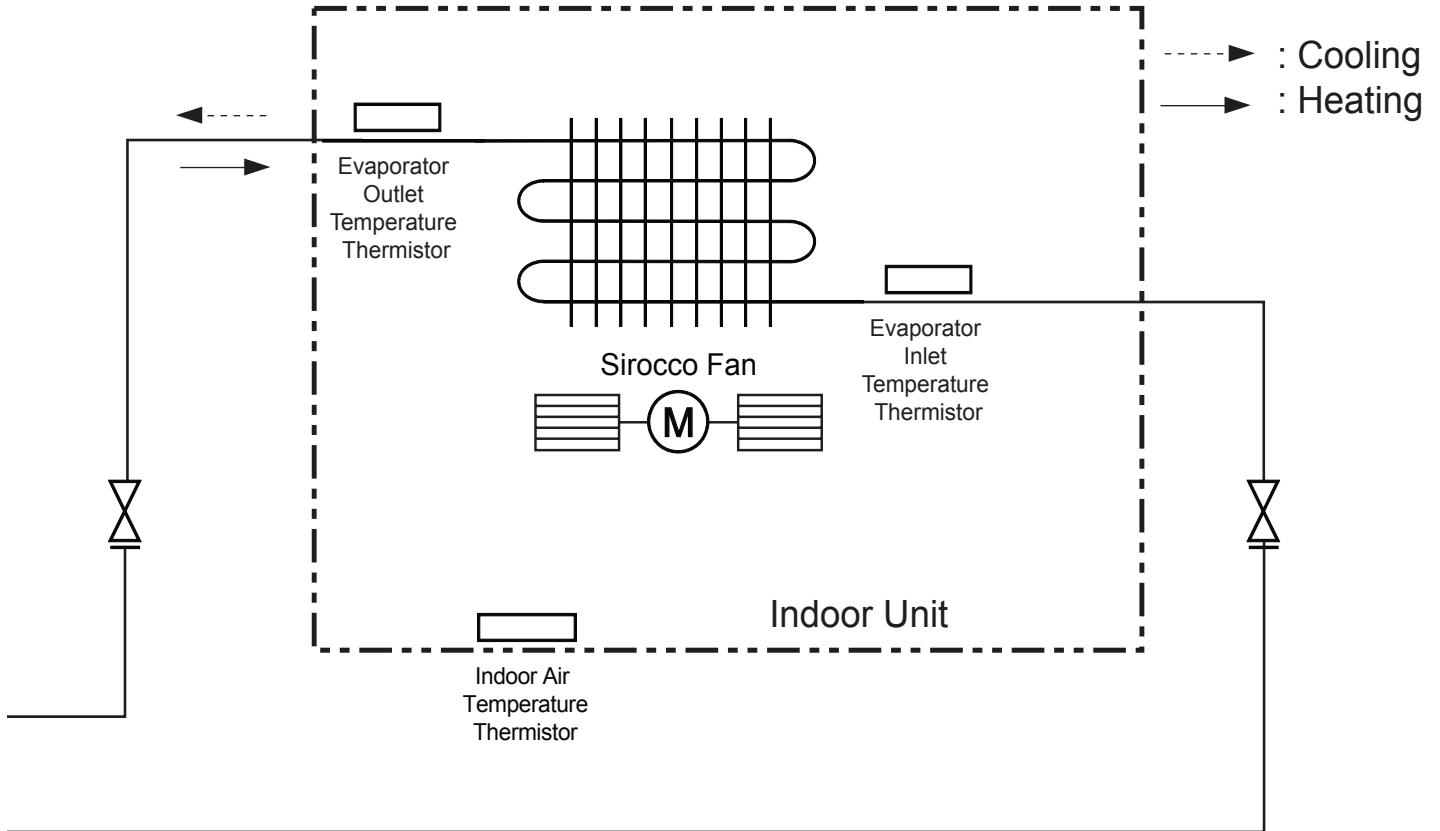

Figure 99: LDN097HV4 Refrigerant Flow Diagram.



Ceiling-Concealed Duct (Low Static)

Table 40: Multi F Ceiling-Concealed Duct (Low Static) LDN097HV4 Indoor Unit Refrigerant Pipe Connection Port Diameters.

Model No.	Vapor (inch)	Liquid (inch)
LDN097HV4	Ø3/8	Ø1/4

Table 41: Multi F Ceiling-Concealed Duct (Low Static) LDN097HV4 Indoor Unit Thermistor Details.

Description (Based on Cooling Mode)	PCB Connector
Indoor Air Temperature Thermistor	CN-ROOM
Evaporator Inlet Temperature Thermistor	CN-PIPE/IN
Evaporator Outlet Temperature Thermistor	CN-PIPE/OUT

DUCT (LOW STATIC) INDOOR UNITS

Refrigerant Flow Diagrams

MULTI F
MULTI F MAX

Figure 100:LDN127HV4 and LMDN186HV Refrigerant Flow Diagram.

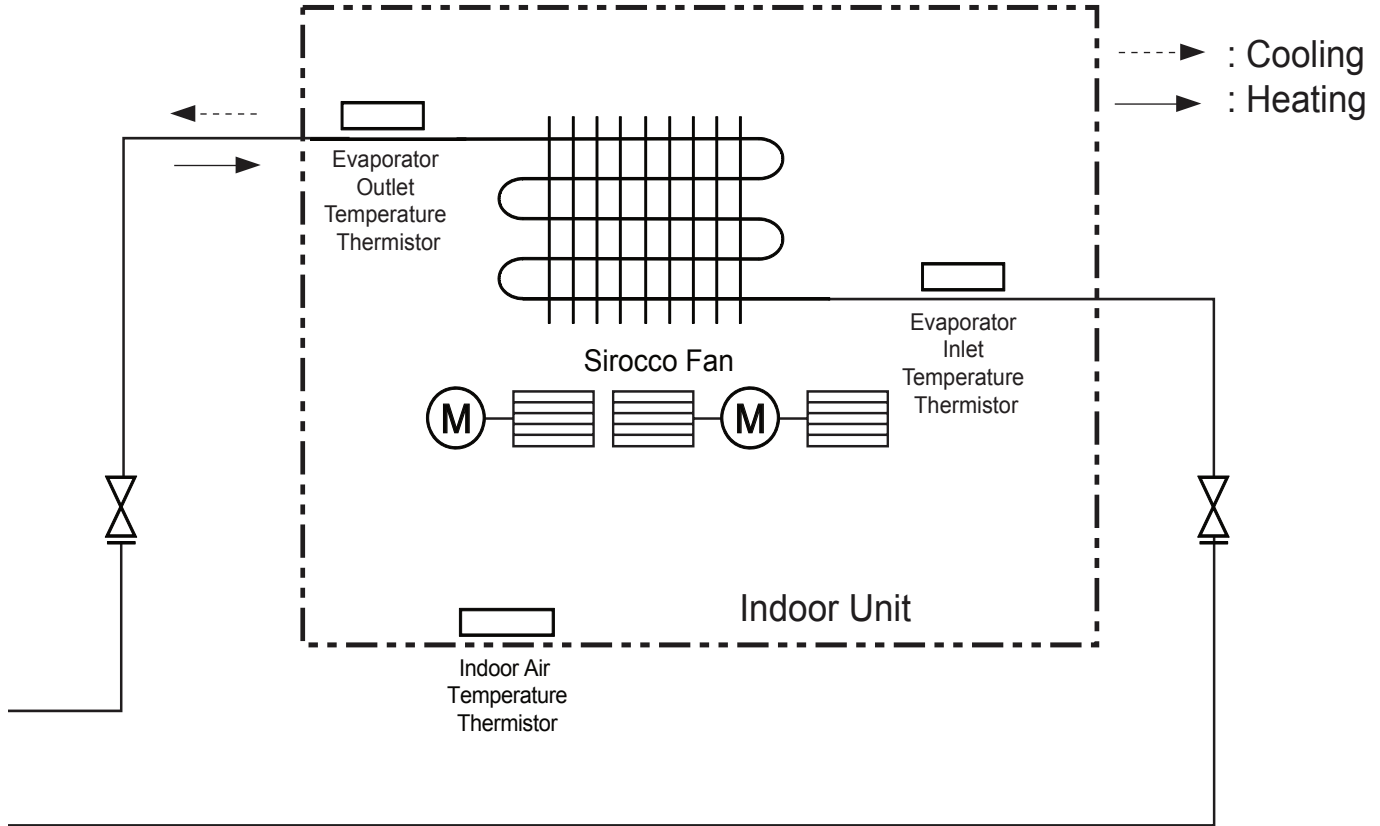

Table 42: Multi F Ceiling-Concealed Duct (Low Static) LDN127HV4 and LMDN186HV Indoor Unit Refrigerant Pipe Connection Port Diameters.

Model No.	Vapor (inch)	Liquid (inch)
LDN127HV4	Ø3/8	Ø1/4
LMDN186HV	Ø1/2	

Table 43: Multi F Ceiling-Concealed Duct (Low Static) LDN127HV4 and LMDN186HV Indoor Unit Thermistor Details.

Description (Based on Cooling Mode)	PCB Connector
Indoor Air Temperature Thermistor	CN-ROOM
Evaporator Inlet Temperature Thermistor	CN-PIPE/IN
Evaporator Outlet Temperature Thermistor	CN-PIPE/OUT

Figure 101: Multi F Ceiling-Concealed Duct (Low Static) LDN097HV4, LDN127HV4, and LMDN186HV Indoor Units Wiring Diagram.

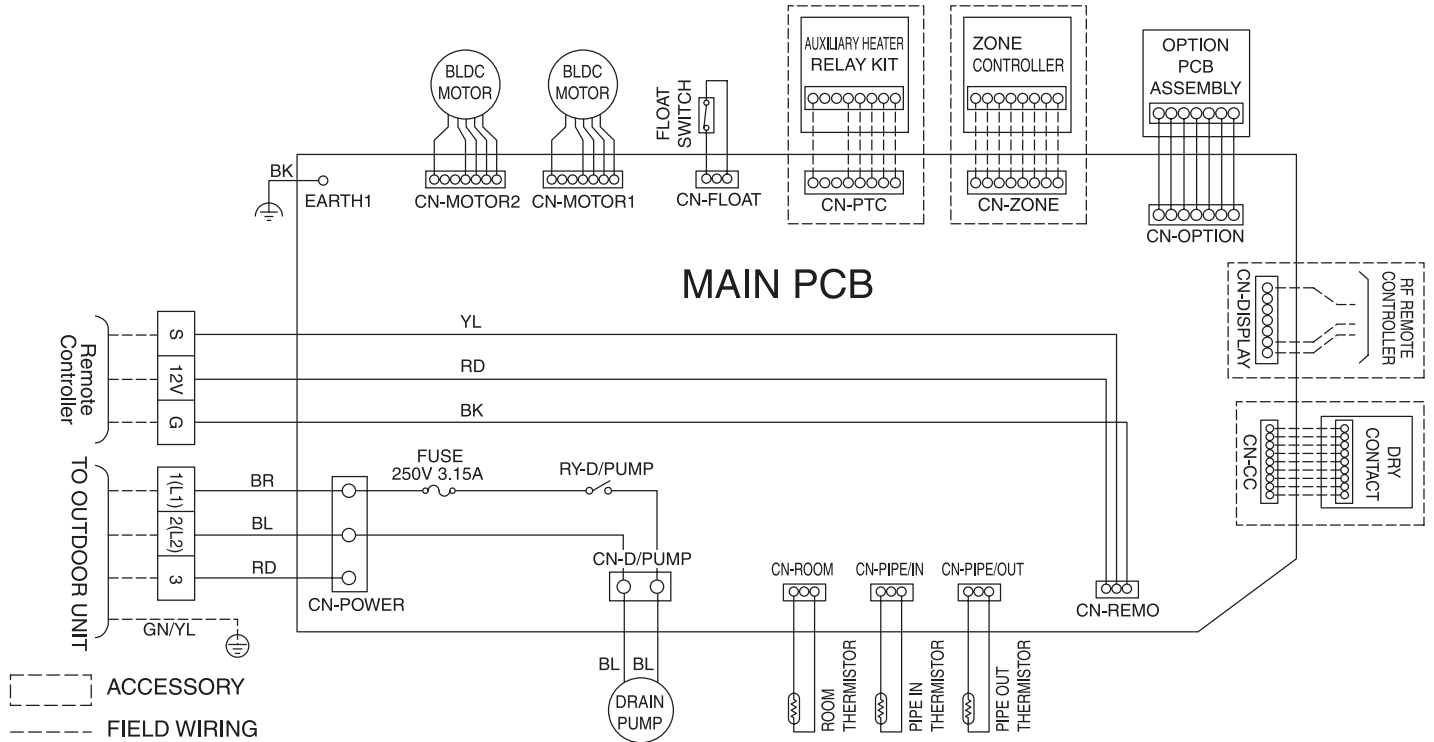

Ceiling-Concealed Duct (Low Static)





DUCT (LOW STATIC) INDOOR UNITS

Factory Supplied Parts and Materials

MULTI F
MULTI F MAX

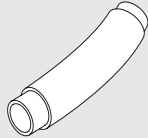
Factory Supplied Parts

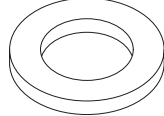
Table 44: Parts Table.

Part	Quantity	Image	Part	Quantity	Image
Drain Hose	One (1)		Zip Ties	Four (4)	
Metal Clamp	Two (2)		Washers for Hanging Brackets	Eight (8)	
Insulation for Fittings	One (1) Set	 For Vapor Piping For Liquid Piping	Simple Controller with Mode Selection (AKB72955816) ¹	One (1)	

¹Simple Mode Controllers for the ceiling-concealed duct (low static) indoor units are also referenced by Model No. PQRCVCL0QW.

Factory Supplied Materials

- Owner's Manual
- Installation Manual

Required Tools

- Level
- Screwdriver
- Electric drill
- Hole core drill
- Flaring tool set
- Torque wrenches
- Hexagonal wrench
- Gas-leak detector
- Thermometer

⚠ WARNING

Installation work must be performed by trained personnel and in accordance with national wiring standards and all local or other applicable codes. Improper installation can result in fire, electric shock, physical injury, or death.

Note:

Read all instructions before installing this product. Become familiar with the unit's components and connections, and the order of installation. Incorrect installation can degrade or prevent proper operation.

Selecting the Best Location

Do's

- Place the unit where air circulation will not be blocked.
- Place the unit where drainage can be obtained easily.
- Place the unit where noise prevention is taken into consideration.
- Ensure there is sufficient strength to bear the load of the indoor unit.
- Ensure there is sufficient maintenance space.
- Locate the indoor unit in a location that is level, and where it can be easily connected to the outdoor unit / branch distribution unit.

Don'ts

- Do not install the unit near a heat or steam source, or where considerable amounts of oil, iron powder, or flour are used.
- Do not install the unit where sulfuric acid and flammable or corrosive gases are generated, vented into, or stored.
- Do not install the unit near high-frequency generators.
- Do not install the unit near a doorway.

The unit may be damaged, may malfunction, and / or will not operate as designed if installed in any of the conditions listed.

Installing in an Area Exposed to Unconditioned Air

In some installation applications, areas (floors, walls) in some rooms may be exposed to unconditioned air (room may be above or next to an unheated garage or storeroom). To countermeasure:

- Verify that carpet is or will be installed (carpet may increase the temperature by three degrees).
- Add insulation between the floor joists.
- Install radiant heat or another type of heating system to the floor.

Installing in an Area with High Humidity Levels

If the environment is prone to humidity levels of 80% or more (near the ocean, lakes, etc.) or where steam could collect in the plenum:

- Install additional insulation to the indoor unit (glass wool insulation >13/32 inches thick).
- Install additional insulation to the refrigerant piping (insulation >13/16 inches thick).
- Seal all gaps between the indoor unit and the ceiling tiles (make the area air tight) so that humidity does not transfer from the plenum to the conditioned space. Also, add a ceiling grille for ventilation.

Note:

If the unit is installed near a body of water, certain components are at risk of being corroded. Appropriate anti-corrosion methods should be taken for the unit and all components.

Figure 102: General Installation Guidelines.

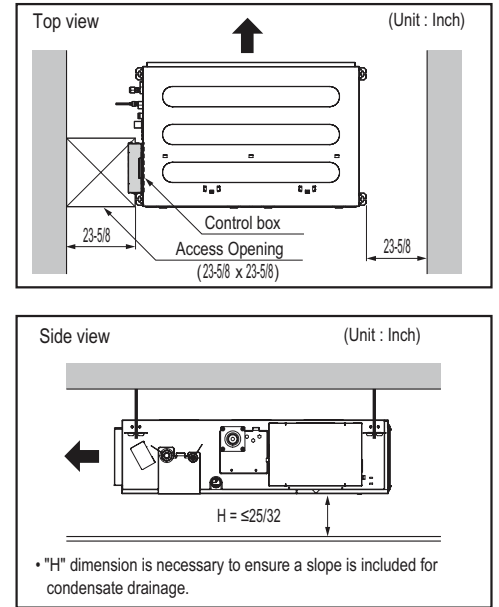

Figure 103: Service / Access Panel Dimensions.

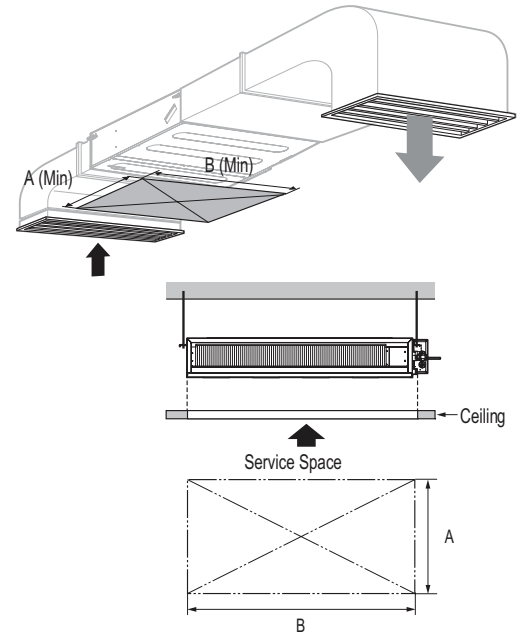

Table 45: General Access Panel Dimensions.

Model / Capacity (Btu/h)	Dimensions (in.)	
	A	B
LDN097HV4 / 9,000	31-1/2	31-1/2
LDN127HV4 / 12,000		39-3/8
LMDN186HV / 18,000		

DUCT (LOW STATIC) INDOOR UNITS

Installation and Best Layout Practices

MULTI F
MULTI F MAX

Duct (Low Static) Indoor Units can be installed in two ways:

Figure 104: Air inlet from the back of the indoor unit.

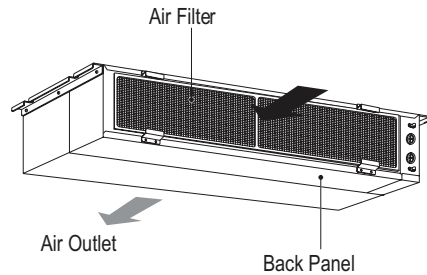

Figure 105: Air inlet from the bottom of the indoor unit.

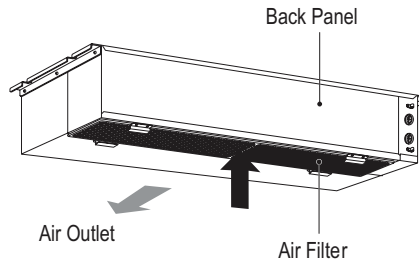

Table 47: Indoor Unit Bolt Locations.

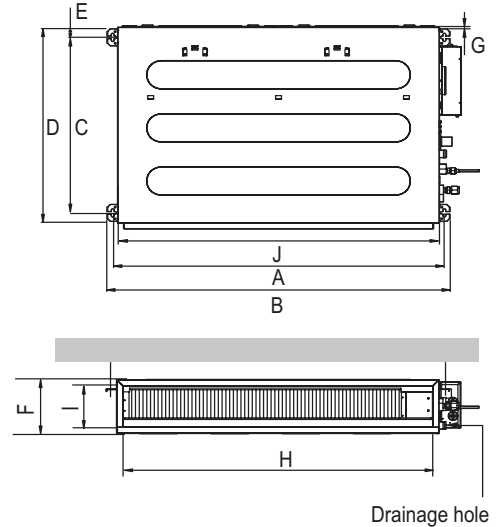

Table 46: Indoor Unit Bolt Location Dimensions.

Model / Capacity (Btu/h)	Dimensions (in.)									
	A	B	C	D	E	F	G	H	I	J
LDN097HV4 / 9,000	28-27/32	30-13/32	24-23/32	27-9/16	1-13/32	7-15/32	25/32	25-31/32	6-3/32	27-9/16
LDN127HV4 / 12,000	36-23/32	38-9/32						33-27/32		35-7/16
LMDN186HV / 18,000										

Preparing the Installation Area and Hanging the Indoor Unit Frame

1. Select and mark the area for the suspension or console bolts (use embedded inserts or anchor bolts in new buildings, and hole-in-anchors in older buildings).
2. Drill the holes.
3. Add the set-anchor and the plate washer to the bolts (bolts should be at least 13/32 inches in diameter), and then insert the bolts into the installation area.
4. Add the plate washer, spring washer, and nut to secure the bolts into the installation area.
5. Position the indoor unit installation plates onto the bolts. Secure using nuts, plate washers, and spring washers. Adjust for level as necessary.

Figure 106: Preparing the Installation Area.

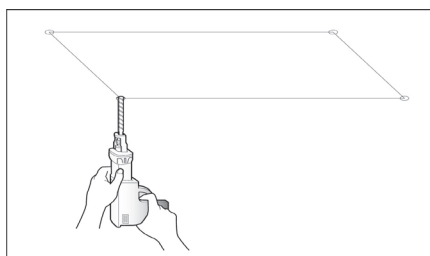

Figure 107: Console Bolt Options.

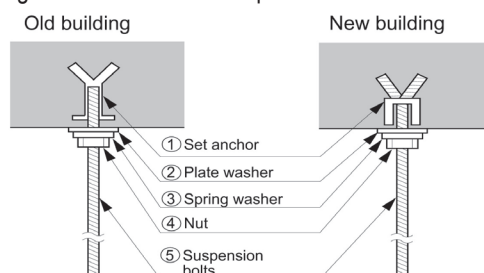
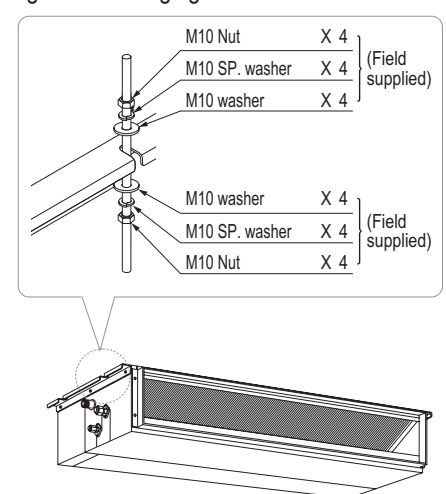

Figure 108: Hanging the Indoor Unit.



Note:

Install a canvas duct to the air outlet and air inlet so that vibration from the indoor unit does not carry to the duct or ceiling. Also, add insulation to the interior of the duct, and apply anti-vibration to the suspension bolts.

WARNING

- Unit must be installed correctly.
- Tighten the nuts and bolts to prevent the unit from falling.

Installing the Drain System

- Drain piping must have downward gradient of at least 1/50 to 1/100; to prevent reverse flow, slope should not be straight up and down.
- Do not damage the drain port on the indoor unit when connecting the field-supplied drain piping.
- Drain piping specifications:
 - Indoor Unit Drain Connection: 1-1/4 inch outside diameter.
 - Field-Supplied Drain Piping: Polyvinyl chloride piping with 1-inch inside diameter and pipe fittings.

Figure 109: Drain Connection.

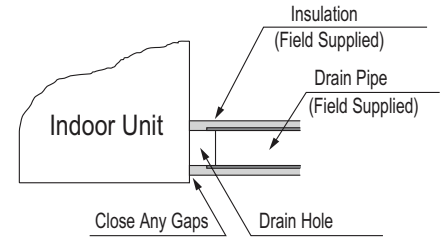

Ducted (low static) indoor units have two options for condensate drainage: Using the factory-installed drain pump, or using a gravity drain.

Using the Drain Pump

- Maximum drain lift is 27-9/16 inches, therefore, the drain piping should be placed below the maximum lift height.
- Field-installed drain piping must have downward gradient of at least 1/50 to 1/100; to prevent reverse flow, slope should not be straight up and down.

Figure 110: Indoor Unit Using Drain Pump.

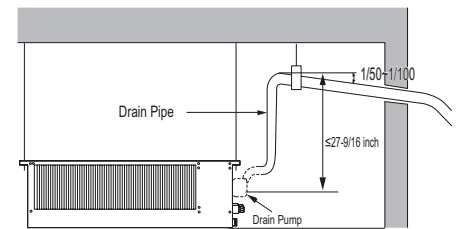

Pump location may be different on the indoor unit.

Using the Gravity Drain

Field-drain piping must have downward gradient of at least 1/50 to 1/100; to prevent reverse flow, slope should not be straight up and down.

Figure 111: Indoor Unit Using Gravity Drain.

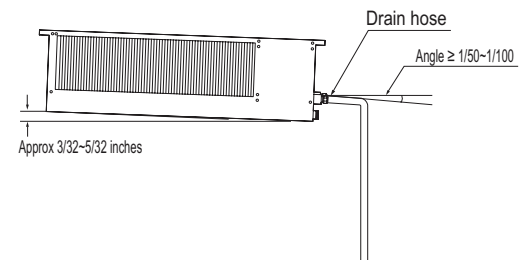

Checking the Drain Pump

The unit uses a drain pump to remove condensate. The pump must be tested before the system operates.

- Connect the flexible drain hose to the field-installed drain piping; leave it as is until the test is complete.
- Pour water into the flexible drain hose and check for leaks.
- After power wiring installation is complete, operate the drain pump to see if it sounds and functions properly.
- After the test is complete, connect the flexible drain hose to the indoor unit drain port.

Figure 112: Checking the Drain Pump.

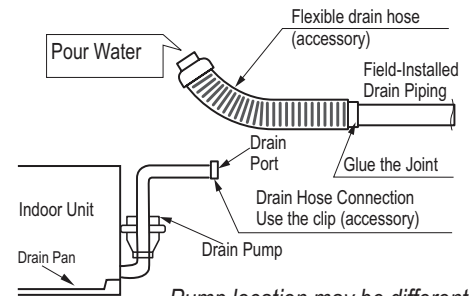

Pump location may be different on the indoor unit.

Checking the Drainage System

1. Remove the air filter.
2. Check the drainage.
 - Spray water on the evaporator.
 - Verify that water flows through the indoor unit drain hose without leaking.

Figure 113: Checking the Drainage System.

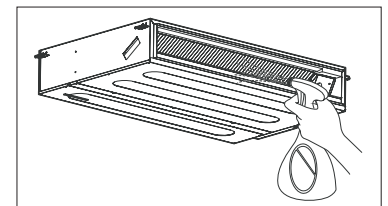
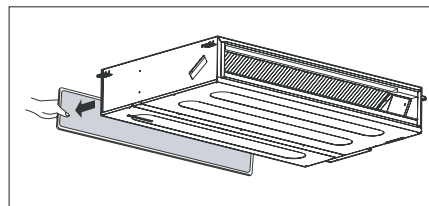

DUCT (LOW STATIC) INDOOR UNITS

Installation and Best Layout Practices

MULTI F
MULTI F MAX

Insulating the Refrigerant and Drain Piping

⚠ WARNING

Ensure all piping is insulated. Exposed piping can cause burns if touched.

Refrigerant Piping Insulation

Field-installed vapor and liquid refrigerant piping lines must be properly and completely covered in insulation (up to the indoor unit piping connections). Any exposed piping may generate condensate or will cause burns if touched. Insulation for this field-installed refrigerant piping must have a minimum heat resistance of 248°F.

Duct (low static) indoor units have been tested under and meet the requirements of the "KS Conditions." If the indoor unit is installed and is operated at an extended period in a highly humid environment (dew point temperature >73°F), however, condensate will form. To prevent this phenomenon, install adiabatic glass wool insulation with a thickness of 13/32 to 13/16 inches thick. Also, install glass wool insulation on all indoor unit that are located in the ceiling plenum.

Drain Piping Insulation

Drain piping must have insulation a minimum of 7/32 inches thick.

Figure 114: Insulating the Piping.

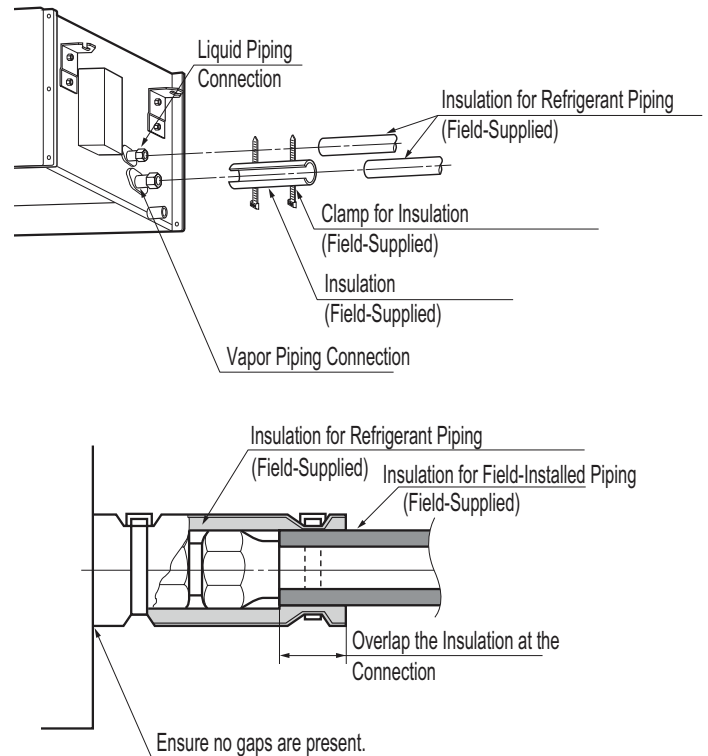

Power Wiring / Communications Cable Guidelines

- Follow manufacturer's circuit diagrams in the technical manuals.
- Confirm power source specifications.
- Confirm that the electrical capacity is sufficient.
- Starting current must be maintained ± 10 percent of the rated current marked on the outdoor unit name plate.
- Confirm cable thickness specifications.
- It is recommended that a circuit breaker is installed, especially if conditions could become wet or moist.
- Include a disconnect in the power wiring system, add an air gap contact separation of at least 1/8 inch in each active (phase) conductor.

⚠ WARNING

- Loose wiring may cause unit to malfunction, overheat, and catch fire, resulting in severe injury or death.

Note:

- Terminal screws may become loose during transport. Properly tighten the terminal connections during installation.
- A voltage drop may cause the following problems:
- Magnetic switch vibration, fuse breaks, or disturbance to the normal function of an overload protection device.
 - Compressor will not receive the proper starting current.

Connecting the Power Wiring and Communications Cable

1. Insert the power wiring / communications cable from the outdoor unit or branch distribution unit (Multi F MAX systems only) through the side of the indoor unit. Pass the wiring through the designated access holes to prevent damage. To prevent electromagnetic interference and product malfunction, leave a space between the power wiring and communications cable outside of the indoor unit.
2. Connect each wire to its appropriate terminal on the indoor unit control board. Verify that the color and terminal numbers from the outdoor unit or branch distribution unit (Multi F MAX systems only) wiring match the color and terminal numbers on the indoor unit.
3. Secure the power wiring / communications cable with the cable restraint.
4. Screw the steel clamp to the inside of the control panel.
 - Place the wiring / cables in the clamp and tighten the plastic clamp to an open surface of the control panel.
 - When clamping, do not apply force to the wiring connections.
 - Neatly arrange the wiring, do not catch the wiring in the electric box cover, and ensure the cover firmly closes.
5. Fill in any gaps around the wiring access hole with sealant to prevent foreign particles from entering the indoor unit.

Using a Conduit

1. Remove the rubber stopper on the indoor unit. Pass the power wiring / communications cable through the conduit, the conduit mounting plate, and to the control panel of the indoor unit.
2. Connect the power wiring / communications cable to the indoor unit terminal block.
3. Screw the conduit mounting plate to the indoor unit.
4. Tighten the conduit and the conduit mounting plate together.

Figure 115: Indoor Unit to Outdoor Unit / Branch Distribution Unit (Multi F MAX systems only) Power Wiring / Communications Cable Connections.

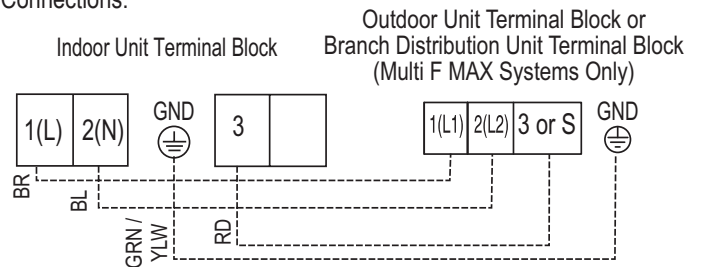
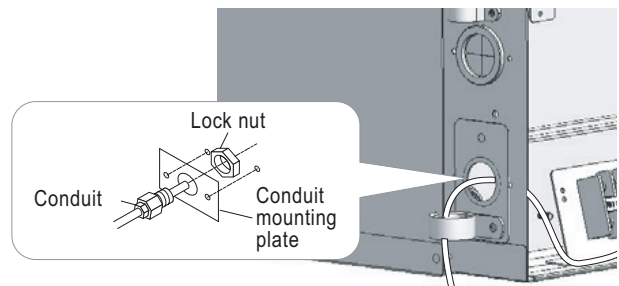

Figure 116: Exterior View of Conduit Installation.



DUCT (LOW STATIC) INDOOR UNITS

Installation and Best Layout Practices

MULTI F
MULTI F MAX

Controller Options

Ceiling-concealed duct (low static) indoor units include an LG-supplied wired controller (AKB72955816)¹, but other optional LG-supplied wired controllers are available. The wireless handheld controller (Model No. PQWRHQ0FDB) is also an optional accessory with use of the wired controller.

- Operation Display Panel: Displays operation conditions.
- Temperature Control Button: Sets desired temperature.
- Fan Speed Button: Sets desired fan speed.
- On / Off Button: Turns system operation on and off.
- Mode Selection Check Button: Selects the operation mode: Cooling, Heating, Auto, Dry (Dehumidification), or Fan.

Wired Controller

Figure 117:AKB72955816¹ Wired Controller.

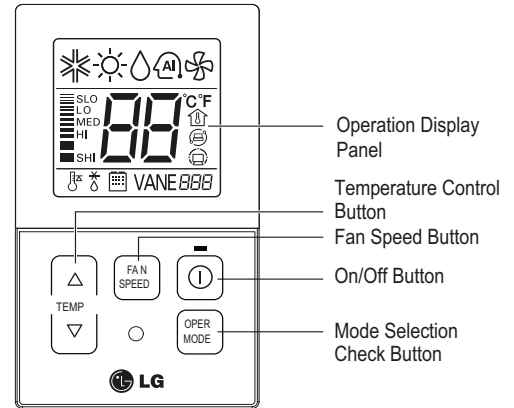

Note:

Each function will display on the LED for about three (3) seconds when the power is first cycled on.

¹Simple Mode Controllers for the ceiling-concealed duct (low static) indoor units are also referenced by Model No. PQRCVCL0QW.

Wired Controller Connections

Controllers can connect to the indoor unit in one of two different ways.

1. LG Wired Remote Extension Cable with Molex plug (PZCWRC1; sold separately) that connects to the CN-REMO terminal on the indoor unit PCB.
2. Field-supplied controller cable that connects to the indoor unit terminal block (must be at least UL2547 or UL1007, 22 AWG, two-core, one-shield core, at least FT-6 rated if local electric and building codes require plenum cable usage).

Figure 118:PZCWRC1 LG Wired Remote Extension Cable.

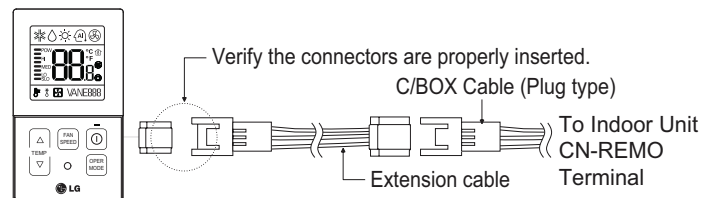
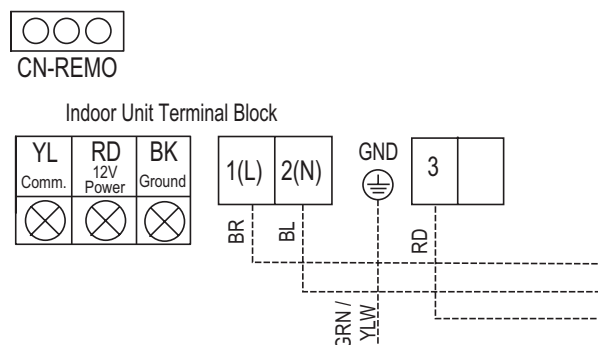

Figure 119:Wired Controller Connections on the Indoor Unit Terminal Block.



Note:

When using field-supplied controller cable, make sure to connect the yellow to yellow (communications wire), red to red (12V power wire), and black to black (ground wire) terminals from the remote controller to the indoor unit terminal blocks.

Hanging the Wired Controller

1. The controller wiring / cable can be installed in one of three directions: top, back, or on the right side. If top or right side installation is desired, remove cable guide grooves on the controller, and then position wiring / cable on applicable side.
2. Choose and mark the area of installation, and then screw the wall plate into place (using the provided parts). Install the controller wall plate to fit the electrical box if one is present. Ensure that no gaps exist between the wall plate and the wall itself.
3. Arrange wiring / cables so as not to interfere with the controller circuitry. Position the wired controller on the wall plate. Snap into place by pressing the bottom part of the wired controller onto the wall plate. Make sure that no gaps exist between the wired controller and the wall plate on all sides.
4. To remove wired controller from the wall plate, insert a screwdriver into the two holes at the bottom. Twist screwdriver to release controller. Do not damage the controller components when removing.

Figure 120: Removing the Cable Guide Grooves.

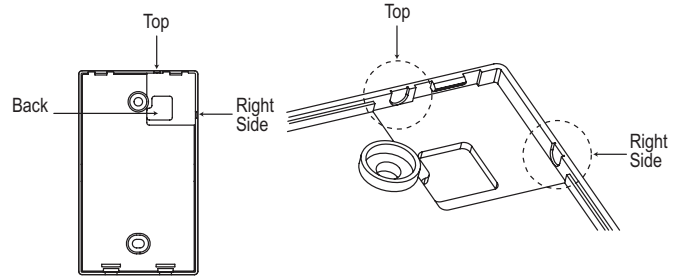

Figure 121: Attaching the Wall Plate.

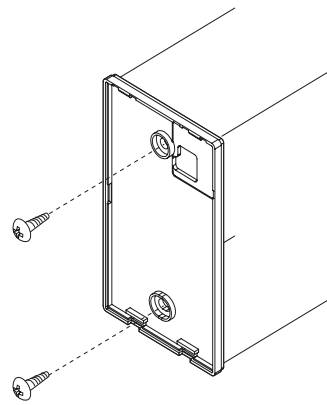
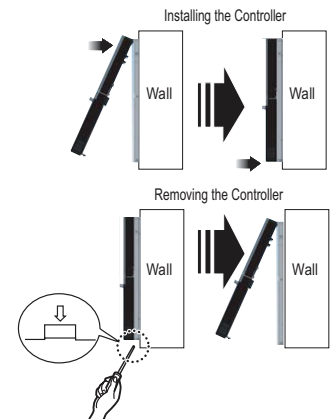

Figure 122: Installing / Removing the Controller.



Assigning the Thermistor for Temperature Detection

Each indoor unit includes a return air thermistor assigned to sense the temperature. If a wired controller is installed, there is a choice of sensing temperature with either the indoor unit return air thermistor or the thermistor in the wired controller. It is also an option to set both thermistors to sense temperature so that indoor unit bases its operation on the first thermistor to reach the designated temperature differential. For applicable indoor units, an optional Remote Temperature Sensor can be used in lieu of the return air thermistor—either alone or in conjunction with a wired controller thermistor as previously described.

Wired Controller Placement

Wired controllers include a sensor to detect room temperature. To maintain comfort levels in the conditioned space, the wired controller must be installed in a location away from direct sunlight, high humidity, and where it could be directly exposed to cold air. Controller must be installed four (4) to five (5) feet above the floor where its LED display can be read easily, in an area with good air circulation, and where it can detect an average room temperature.

- ⊘ Do not install the wired controller near or in:
 - Drafts or dead spots behind doors and in corners
 - Hot or cold air from ducts
 - Radiant heat from the sun or appliances
 - Concealed pipes and chimneys
 - An area where temperatures are uncontrolled, such as an outside wall

Figure 123: Proper Location for the Wired Controller.

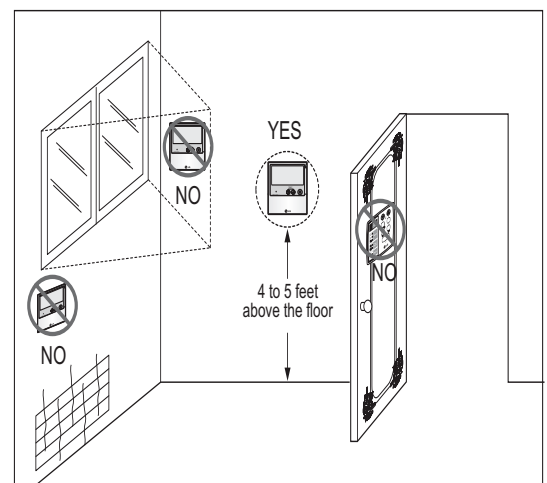

DUCT (LOW STATIC) INDOOR UNITS

Installation and Best Layout Practices

MULTI F
MULTI F MAX

External Static Pressure Control

To provide a required air flow rate that accounts for the external static pressure change, follow the steps below.

1. To access system installer setting mode, press and hold the temperature increase and mode selection buttons simultaneously for approximately three (3) seconds. Choose setting code value "06" by pressing the mode selection button.
2. Use the temperature increase and decrease buttons to select the desired setting value.

Figure 124: Select Code and Set Value.

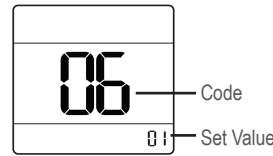
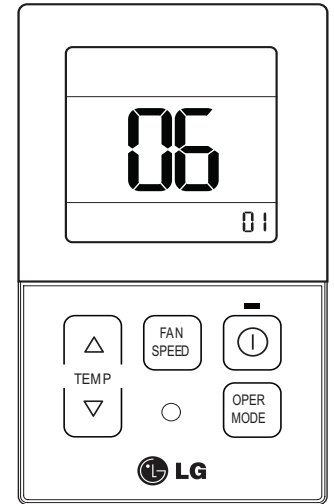

Figure 125: Controller External Static Pressure Setting Display.



Setting Values

- 01 : V-H
- 02 : F-H
- 03 : V-L
- 04 : F-L

3. Press the on / off button to save the established settings.
4. To deactivate system installer setting mode after the settings have been established, press and hold the temperature increase and mode selection check buttons simultaneously for approximately three (3) seconds. If a button is not pressed for more than 25 seconds, the system installer setting mode will automatically deactivate.

Table 48: Static Pressure Setting Table.

Pressure Selection		Function	
		Zone State	External Static Pressure Standard Value
01	V-H	Variable	High
02	F-H	Fixed	High
03	V-L	Variable	Low
04	F-L	Fixed	Low

Note:

- Select the position after verifying duct work and the external static pressure of the indoor unit.
- Factory set to pressure selection F-H.

Assigning Air Flow

To assign an air flow for each fan speed, follow the steps below.

1. To access system installer setting mode, press and hold the temperature increase and mode selection buttons simultaneously for approximately three (3) seconds. Choose setting code value "03" by pressing the mode selection button.
2. Use the fan speed button to select the desired fan speed. (Lo→Med→Hi will display on the LED).
3. Use the temperature increase and decrease buttons to select the desired external static pressure setting value (thereby assigning the respective airflow). External static pressure value range: 0~255; the value will display near the lower right corner of the LED.
4. Press the on / off button to save the established settings.
5. To deactivate system installer setting mode after the settings have been established, press and hold the temperature increase and mode selection check buttons simultaneously for approximately three (3) seconds. If a button is not pressed for more than 25 seconds, the system installer setting mode will automatically deactivate.

Figure 126: Controller External Static Pressure Setting Display.

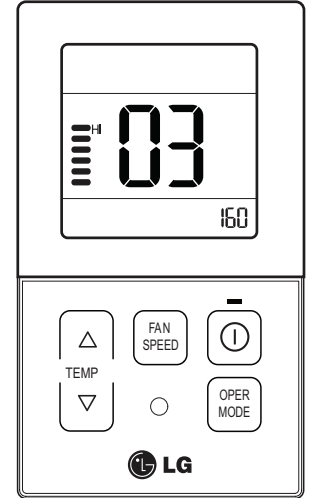

Note:

- A certified technician must set the external static pressure value(s). If the external static pressure is set incorrectly, the system may malfunction.
- Do not alter the external static pressure value that corresponds to each air flow level.
- External static pressure value can vary depending on the indoor unit.
- If by pressing the fan speed button during external static pressure setup, the fan speed is raised to the next level, the air flow value of the previous fan speed will be maintained (external static pressure setting value is saved).

CEILING-CONCEALED DUCT (HIGH STATIC) INDOOR UNIT DATA

“Mechanical Specifications” on page 95

“General Data / Specifications” on page 96

“Dimensions” on page 97

“Cooling Capacity Table” on page 98

“Heating Capacity Table” on page 99

“External Static Pressure” on page 100

“Acoustic Data” on page 100

“Refrigerant Flow Diagrams” on page 101

“Wiring Diagram” on page 102

“Factory Supplied Parts and Materials” on page 103

“Installation and Best Layout Practices” on page 104

Ceiling-Concealed Duct (High Static) Indoor Unit

General

All LG indoor units are factory assembled, wired, piped, and provided with a control circuit board, fan, and motor. Ceiling-Concealed Duct (High Static) units are designed for high-speed air volume against an external static pressure up to 0.78"WG for the 24,000 Btu/h model; up to 0.55"WG for the 36,000 Btu/h model.

Coil

Indoor unit coils are factory built and are comprised of aluminum fins mechanically bonded to copper tubing. Each unit has two rows of coils, which are pressure tested at the factory. Each unit is provided with a factory installed condensate drain pan below the coil.

Refrigerant System

System is designed for use with R410A refrigerant. The refrigeration circuit is pressure-tested at the factory and shipped with a holding charge of helium gas. Refrigerant pipe connections are 45° flare, and all refrigerant lines from the outdoor unit to the indoor units must be field insulated.

Electrical

Each indoor unit is designed to operate using 208–230/60/1 power with voltage variances of ±10%.

Casing

The casing is designed to mount fully concealed above a finished ceiling. Casing is manufactured of galvanized steel plate. Cold surfaces of the unit are covered internally with a coated polystyrene insulating material, and covered externally with sheet insulation made of ethylene propylene diene monomer (M-Class) (EPDM). External insulation is plenum rated and conforms to ASTM Standard D-1418. Hanger brackets are included on the casing to support the weight on four corners. Unit has a front horizontal supply air discharge outlet, and one dedicated rear horizontal return air inlet.

Fan Assembly and Control

The units have two direct-drive, Sirocco fans made of high strength ABS GP-2200 polymeric resin that are statically and dynamically balanced. The fans are mounted on a common brushless digitally controlled (BLDC) motor with permanently lubricated and sealed ball bearings. The fan / motor assembly is mounted on vibration-attenuating rubber grommets. Fan speed is controlled using a microprocessor-based direct digital control algorithm. The indoor fan has Low, Med, High, and Auto settings for Cooling mode; and has Low,

Features

- Inverter (Variable speed fan)
- Internal drain pump
- Control lock function
- Auto operation
- Auto restart operation
- Dehumidifying function
- Two thermistor control
- External static pressure control
- Group control
- Self-diagnostics function
- Wired thermostat included

Figure 127: Ceiling-Concealed Duct (High Static) Indoor Unit.



Med, High, and Auto settings for Heating mode. Each of the settings can be field-adjusted from the factory setting (RPM / ESP). The Auto setting adjusts the fan speed based on the difference between the controller setpoint and space temperature.

Air Filter

Return air is filtered with a factory-supplied, removable, washable filter accessible from the rear of the indoor unit. High efficiency air filter options include a return filter box and an LG / Dynamic supplied air cleaner (both sold separately).

Microprocessor Control

The unit is provided with an integrated control panel to communicate with the outdoor unit. All unit operation parameters are stored in non-volatile memory resident on the unit microprocessor. The microprocessor controls space temperature through using the value provided by the temperature sensor within the indoor unit. The microprocessor control will activate indoor unit operation when the indoor room temperature falls below or rises above a setpoint temperature, at which point, a signal is sent to the outdoor unit to begin the appropriate mode. The microprocessor will also provide self-diagnostics and auto restart functions. A field-supplied four-wire power / communications cable must be installed to connect the indoor unit(s) to the outdoor unit.

Controls

The indoor unit is supplied with an LG wired controller. Communication between the indoor units and the outdoor unit is accomplished through 18 AWG, four-core, stranded and shielded power / communication cable.

Condensate Lift/Pump

The indoor unit is provided with a factory installed and wired internal condensate lift/pump capable of providing a minimum 27.5 inch lift from the bottom surface of the unit. Drain pump has a safety switch to shut off the indoor unit if the condensate rises too high in the drain pan.

DUCT (HIGH STATIC) INDOOR UNITS

General Data / Specifications

MULTI F
MULTI F MAX

Table 49: Multi F Ceiling-Concealed High-Static Ducted Indoor Unit General Data.

Model Name	LMHN240HV	LMHN360HV
Nominal Cooling Capacity (Btu/h) ¹	24,000	36,000
Nominal Heating Capacity (Btu/h) ¹	27,000	40,000
<i>Operating Range</i>		
Cooling (°F WB)	57-77	57-77
Heating (°F DB)	59-81	59-81
<i>Fan</i>		
Type	Sirocco	Sirocco
Motor Output (W) x Qty.	154 x 1	350 x 1
Motor/Drive	Brushless Digitally Controlled / Direct	Brushless Digitally Controlled / Direct
Factory Set Airflow Rate CFM (H/M/L)	688 / 618 / 530	1,130 / 953 / 706
Factory Set External Static Pressure (in. wg)	0.39	0.39
Maximum External Static Pressure (in. wg)	0.78	0.55
<i>Unit Data</i>		
Refrigerant Type ²	R410A	R410A
Refrigerant Control	EEV	EEV
Power Supply V, Ø, Hz ³	208-230, 1, 60	208-230, 1, 60
Rated Amps (A)	0.9	1.4
Sound Pressure Level (Standard Mode) ±3 dB(A) H/M/L ⁴	37 / 36 / 35	44 / 42 / 40
Dimensions (W x H x D, in.)	46-17/32 x 11-23/32 x 17-23/32	46-17/32 x 11-23/32 x 17-23/32
Net Unit Weight (lbs.)	80	91
Shipping Weight (lbs.)	91	101
Power Wiring / Communications Cable (No. x AWG) ⁵	4 x 18	4 x 18
Heat Exchanger (Row x Column x Fin / inch) x Number	(2 x 12 x 21) x 1	(3 x 12 x 21) x 1
<i>Piping</i>		
Liquid (in.)	1/4	3/8
Vapor (in.)	1/2	5/8
Drain O.D. / I.D. (in.)	1-1/4, 1	1-1/4, 1

¹Nominal capacity is rated 0 ft. above sea level with corresponding refrigerant piping length in accordance with standard length of each outdoor unit and a 0 ft. level difference between outdoor and indoor units. All capacities are net with a combination ratio between 95 – 105%.

Nominal cooling capacity rating obtained with air entering the indoor unit at 80°F dry bulb (DB) and 67°F wet bulb (WB) and outdoor ambient conditions of 95°F dry bulb (DB) and 75°F wet bulb (WB).
Nominal heating capacity rating obtained with air entering the indoor unit at 70°F dry bulb (DB) and 60°F wet bulb (WB) and outdoor ambient conditions of 47°F dry bulb (DB) and 43°F wet bulb (WB).

²This unit comes with a dry helium charge.

³Acceptable operating voltage: 187V-253V.

⁴Sound pressure levels are tested in an anechoic chamber under ISO Standard 3745 and are the same in both cooling and heating mode. These values can increase due to ambient conditions during operation.

⁵All power wiring / communications cable to the IDUs be minimum 18 AWG, 4-conductor, stranded, shielded or unshielded (if shielded, must be grounded to chassis at ODU only) and must comply with applicable local and national codes.

Figure 128: LMHN240HV and LMHN360HV Dimensions.

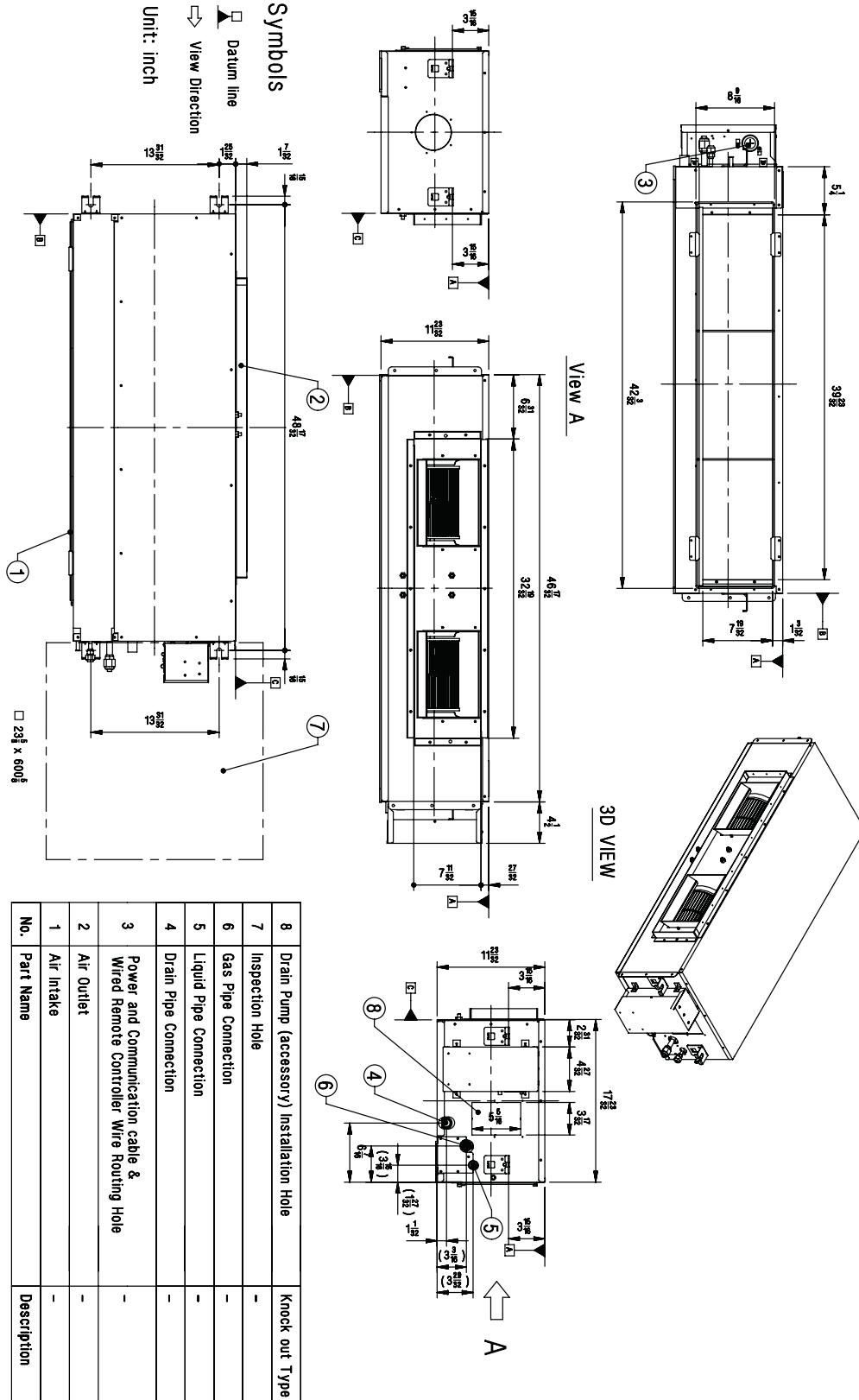

Ceiling-Concealed Duct (High Static)

DUCT (HIGH STATIC) INDOOR UNITS

Cooling Capacity Table

MULTI F
MULTI F MAX

Table 50: Multi F Ceiling-Concealed Duct (High Static) Indoor Units Cooling Capacity Table.

Model No. / Nominal Capacity of Indoor Unit (Btu/h)	Outdoor Air Temp. (°F DB)	Indoor Air Temp. °F DB / °F WB											
		68 / 57		73 / 61		77 / 64		80 / 67		86 / 72		90 / 75	
		TC	SHC	TC	SHC	TC	SHC	TC	SHC	TC	SHC	TC	SHC
LMHN240HV 24,000	14	23.53	17.66	24.99	18.66	26.45	18.07	27.50	18.45	29.37	18.60	30.83	18.95
	20	23.51	17.80	24.97	18.80	26.43	18.21	27.48	18.59	29.35	18.75	30.81	19.10
	25	23.49	17.94	24.95	18.95	26.41	18.35	27.46	18.73	29.33	18.89	30.79	19.25
	30	23.47	18.08	24.93	19.09	26.39	18.49	27.44	18.88	29.30	19.04	30.76	19.40
	35	23.46	18.21	24.91	19.24	26.37	18.63	27.42	19.02	29.28	19.18	30.74	19.54
	40	23.44	18.35	24.89	19.38	26.35	18.77	27.40	19.16	29.26	19.33	30.72	19.69
	45	23.42	18.49	24.87	19.53	26.33	18.91	27.38	19.31	29.24	19.47	30.69	19.84
	50	23.40	18.62	24.85	19.67	26.31	19.05	27.36	19.45	29.21	19.61	30.67	19.99
	55	23.38	18.76	24.84	19.82	26.29	19.19	27.34	19.59	29.19	19.76	30.64	20.13
	60	23.37	18.90	24.82	19.96	26.27	19.33	27.32	19.73	29.17	19.90	30.62	20.28
	65	23.35	19.03	24.80	20.10	26.25	19.47	27.29	19.88	29.15	20.04	30.60	20.42
	70	23.33	19.17	24.78	20.25	26.23	19.61	27.27	20.02	29.13	20.19	30.57	20.57
	75	22.77	18.85	24.21	19.94	25.66	19.33	26.70	19.75	28.55	19.94	29.99	20.34
	80	22.21	18.53	23.65	19.63	25.09	19.05	26.13	19.48	27.97	19.69	29.42	20.10
	85	21.65	18.19	23.09	19.30	24.53	18.75	25.57	19.19	27.40	19.43	28.84	19.84
	90	21.09	17.85	22.53	18.96	23.96	18.45	25.00	18.90	26.83	19.15	28.27	19.59
	95	20.49	17.66	21.92	18.79	23.35	18.31	24.00	18.48	26.20	19.05	27.63	19.50
	100	19.99	17.19	21.42	18.31	22.85	17.87	23.69	18.19	25.70	18.64	27.13	19.10
105	19.49	16.71	20.92	17.84	22.35	17.43	23.38	17.91	25.20	18.23	26.63	18.70	
110	18.99	16.14	20.42	17.26	21.85	16.90	22.88	17.37	24.70	17.71	26.13	18.19	
115	18.49	15.66	19.92	16.78	21.35	16.45	22.38	16.93	24.20	17.29	25.63	17.77	
118	18.19	15.55	19.62	16.68	21.05	16.36	22.08	16.86	23.90	17.23	25.33	17.72	
122	18.10	15.51	19.52	16.64	20.95	16.34	21.98	16.83	23.81	17.21	25.23	17.71	
LMHN360HV 36,000	14	35.29	25.46	37.48	26.90	39.67	26.04	41.26	26.59	44.06	26.81	46.25	27.32
	20	35.26	25.66	37.45	27.11	39.64	26.25	41.23	26.80	44.02	27.02	46.21	27.54
	25	35.24	25.86	37.43	27.32	39.61	26.45	41.19	27.01	43.99	27.23	46.18	27.75
	30	35.21	26.06	37.40	27.53	39.58	26.65	41.16	27.21	43.96	27.44	46.14	27.96
	35	35.18	26.25	37.37	27.73	39.55	26.85	41.13	27.42	43.92	27.65	46.11	28.17
	40	35.16	26.45	37.34	27.94	39.52	27.06	41.10	27.63	43.89	27.86	46.07	28.39
	45	35.13	26.65	37.31	28.15	39.49	27.26	41.07	27.83	43.86	28.07	46.04	28.60
	50	35.10	26.85	37.28	28.36	39.46	27.46	41.04	28.04	43.82	28.27	46.00	28.81
	55	35.08	27.04	37.25	28.57	39.43	27.66	41.01	28.24	43.79	28.48	45.97	29.02
	60	35.05	27.24	37.23	28.78	39.40	27.86	40.97	28.45	43.76	28.69	45.93	29.23
	65	35.02	27.44	37.20	28.98	39.37	28.06	40.94	28.65	43.72	28.90	45.90	29.44
	70	34.99	27.63	37.17	29.19	39.34	28.26	40.91	28.86	43.69	29.10	45.86	29.65
	75	34.15	27.18	36.32	28.75	38.49	27.87	40.05	28.47	42.82	28.75	44.99	29.32
	80	33.31	26.71	35.47	28.29	37.64	27.46	39.20	28.08	41.96	28.39	44.12	28.97
	85	32.48	26.23	34.63	27.82	36.79	27.03	38.35	27.66	41.10	28.00	43.26	28.61
	90	31.64	25.73	33.79	27.33	35.94	26.59	37.50	27.24	40.25	27.61	42.40	28.23
	95	30.74	25.46	32.88	27.09	35.02	26.39	36.00	26.64	39.30	27.46	41.44	28.11
	100	29.99	24.78	32.13	26.40	34.27	25.76	35.53	26.23	38.55	26.87	40.69	27.53
105	29.24	24.10	31.38	25.72	33.52	25.13	35.07	25.82	37.80	26.28	39.94	26.96	
110	28.49	23.27	30.63	24.89	32.77	24.36	34.32	25.04	37.05	25.54	39.20	26.22	
115	27.74	22.58	29.88	24.19	32.02	23.71	33.57	24.41	36.31	24.93	38.45	25.62	
118	27.29	22.41	29.43	24.04	31.57	23.59	33.12	24.30	35.86	24.84	38.00	25.55	
122	27.14	22.36	29.28	23.99	31.43	23.55	32.97	24.26	35.71	24.81	37.85	25.53	

TC = Total Capacity (kBtu/h).

SHC: Sensible Heat Capacity (kBtu/h).

Nominal capacity as rated 0 ft. above sea level and a 0 ft. level difference between outdoor and indoor units. Corresponding refrigerant piping length is accordance with standard length of each outdoor unit.

Nominal cooling capacity rating obtained with air entering the indoor unit at 80°F dry bulb (DB) and 67°F wet bulb (WB), and outdoor ambient conditions of 95°F dry bulb (DB) and 75°F wet bulb (WB).

The shaded table columns and rows indicate reference data. When operating at this temperature, these values can be different if the system is not running consistently.

Multi F and Multi F MAX Indoor Unit Engineering Manual

Table 51: Multi F Ceiling-Concealed Duct (High Static) Indoor Units Heating Capacity Table.

Model No. / Nominal Capacity of Indoor Unit (Btu/h)	Outdoor Air Temp.		Indoor Air Temp. °F DB					
	°F DB	°F WB	61	64	68	70	72	75
			TC	TC	TC	TC	TC	TC
LMHN240HV 24,000	0	-0.4	13.89	13.70	13.57	13.50	13.30	12.72
	5	4.5	15.65	15.46	15.33	15.26	15.07	14.48
	10	9	17.41	17.22	17.09	17.02	16.83	16.24
	17	15	19.76	19.57	19.43	19.37	19.17	18.55
	20	19	20.64	20.45	20.32	20.25	20.05	19.37
	25	23	22.11	21.91	21.78	21.72	21.52	20.74
	30	28	23.38	23.18	23.05	22.99	22.79	22.11
	35	32	24.65	24.46	24.33	24.26	24.07	23.48
	40	36	25.79	25.60	25.47	25.40	25.21	24.62
	45	41	26.93	26.74	26.61	26.54	26.35	25.76
	47	43	27.39	27.20	27.07	27.00	26.80	26.22
	50	46	27.83	27.64	27.51	27.44	27.24	26.58
	55	51	28.57	28.37	28.24	28.17	27.98	27.20
	60	56	28.57	28.37	28.24	28.17	27.98	27.32
63	59	28.57	28.37	28.24	28.17	27.98	27.39	
68	64	28.57	28.37	28.24	28.17	27.98	27.51	
LMHN360HV 36,000	0	-0.4	20.58	20.29	20.10	20.00	19.71	18.84
	5	4.5	23.19	22.90	22.71	22.61	22.32	21.45
	10	9	25.80	25.51	25.31	25.22	24.93	24.06
	17	15	29.28	28.99	28.79	28.70	28.41	27.48
	20	19	30.58	30.29	30.10	30.00	29.71	28.70
	25	23	32.75	32.46	32.27	32.17	31.88	30.72
	30	28	34.64	34.35	34.15	34.06	33.77	32.75
	35	32	36.52	36.23	36.04	35.94	35.65	34.78
	40	36	38.21	37.92	37.73	37.63	37.34	36.47
	45	41	39.90	39.61	39.42	39.32	39.03	38.16
	47	43	40.58	40.29	40.10	40.00	39.71	38.84
	50	46	41.23	40.94	40.75	40.65	40.36	39.38
	55	51	42.32	42.03	41.84	41.74	41.45	40.29
	60	56	42.32	42.03	41.84	41.74	41.45	40.47
63	59	42.32	42.03	41.84	41.74	41.45	40.58	
68	64	42.32	42.03	41.84	41.74	41.45	40.76	

TC = Total Capacity (kBtu/h).

Nominal capacity as rated 0 ft. above sea level and a 0 ft. level difference between outdoor and indoor units. Corresponding refrigerant piping length is accordance with standard length of each outdoor unit. Nominal heating capacity rating obtained with air entering the indoor unit at 70°F dry bulb (DB) and 60°F wet bulb (WB), and outdoor ambient conditions of 47°F dry bulb (DB) and 43°F wet bulb (WB).

Ceiling-Concealed Duct (High Static)

DUCT (HIGH STATIC) INDOOR UNITS

External Static Pressure / Acoustic Data

MULTI F
MULTI F MAX

Table 52: Multi F Ceiling-Concealed Duct (High Static) External Static Pressure Setting Values Table.

Static Pressure (in. wg)		0.1	0.16	0.23	0.31	0.39	0.47	0.55	0.62	0.70	0.78	
Model No. / Nominal Capacity of Indoor Unit (Btu/h)	Airflow Rate / CFM	Setting Value (in. wg)										
	LMHN240HV 24,000	High	688	82	92	103	113	122	131	140	147	154
Mid		618	78	89	99	110	119	128	137	144	151	157
Low		530	73	86	96	107	116	125	134	141	148	154
LMHN360HV 36,000	High	1,130	-	124	133	140	148	154	160	-	-	-
	Mid	953	-	112	122	130	137	145	152	-	-	-
	Low	706	-	97	107	117	125	133	141	-	-	-

Note:

- To get the desired air flow and external static pressure combination, use the setting value from the table. Using a setting value other than that listed in the table will not provide the desired combination.
- Table data is based at 230V. Air flow rate varies according to voltage fluctuation.

Figure 129: Sound Pressure Level Measurement Location.

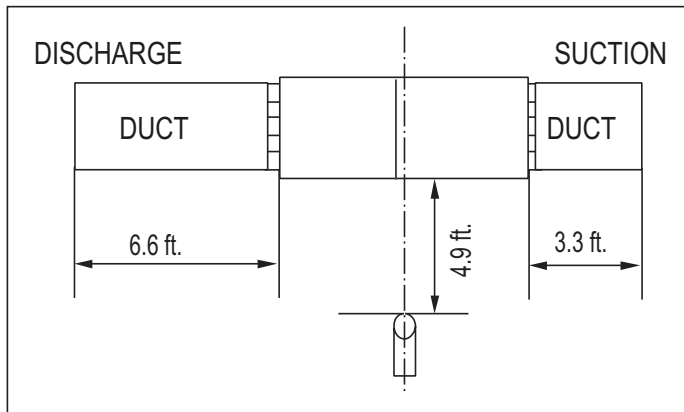

- Measurements taken with no attenuation and units operating at full load normal operating condition.
- Sound level will vary depending on a range of factors such as construction (acoustic absorption coefficient) of particular area in which the equipment is installed.
- Sound power levels are measured in dB(A)±3.
- Tested in anechoic chamber per ISO Standard 3745.

Table 53: Sound Pressure Levels (dB[A]).

Model No.	Sound Pressure Levels (dB[A]) (Cooling and Heating)		
	High Fan Speed	Medium Fan Speed	Low Fan Speed
LMHN240HV	37	36	35
LMHN360HV	44	42	40

Figure 130: Sound Pressure Level Diagrams.

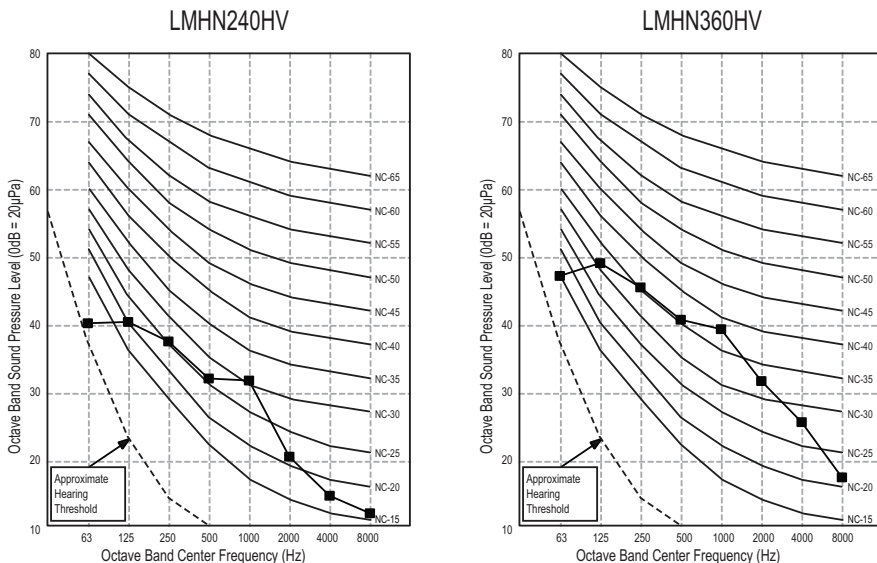

Figure 131: LMHN240HV and LMHN360HV Refrigerant Flow Diagram.

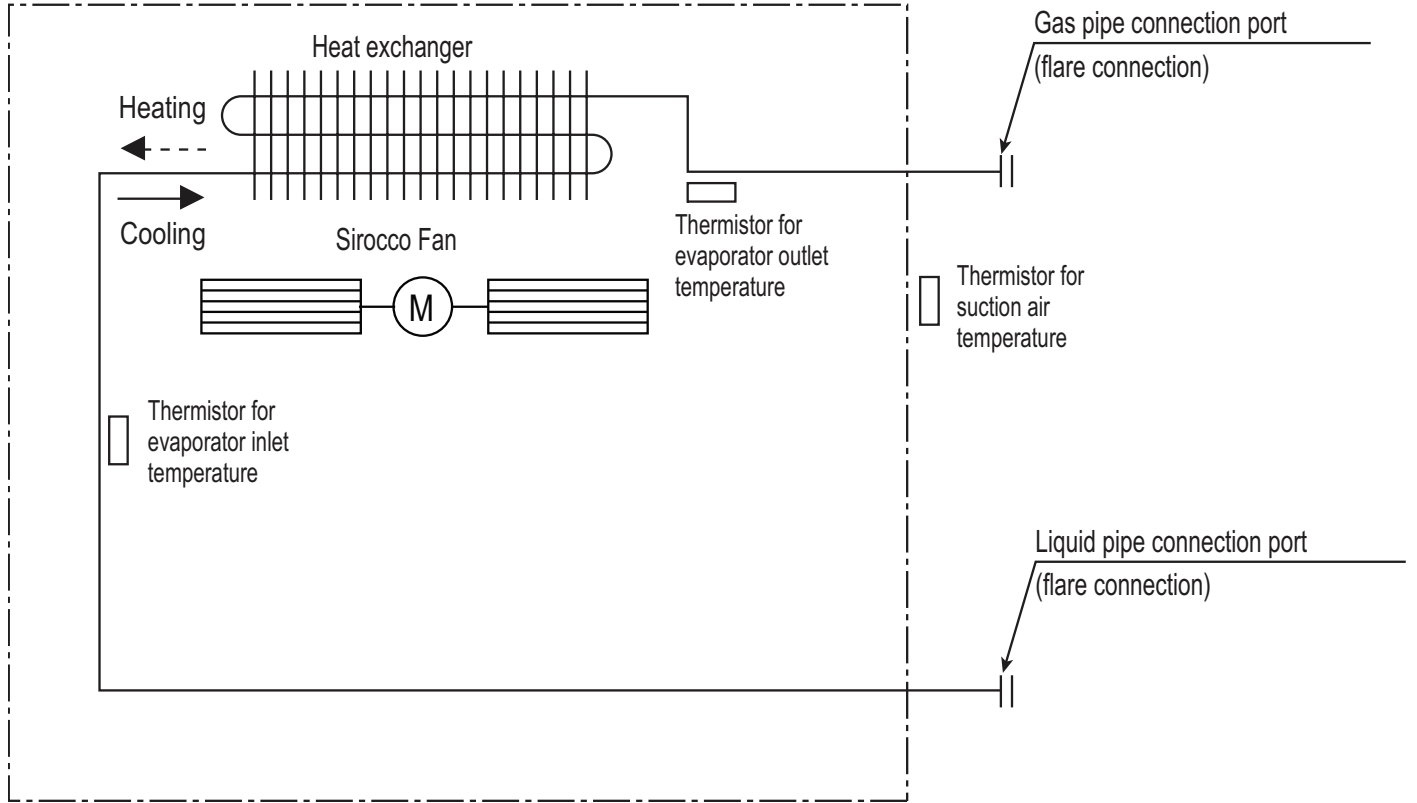

Table 54: Multi F Ceiling-Concealed Duct (High Static) Indoor Unit Refrigerant Pipe Connection Port Diameters.

Model No.	Vapor (inch)	Liquid (inch)
LMHN240HV	Ø1/2	Ø1/4
LMHN360HV	Ø5/8	Ø3/8

Table 55: Multi F Ceiling-Concealed Duct (High Static) Indoor Unit Thermistor Details.

Description (Based on Cooling Mode)	PCB Connector
Indoor Air Temperature Thermistor	CN-ROOM
Evaporator Inlet Temperature Thermistor	CN-PIPE/IN
Evaporator Outlet Temperature Thermistor	CN-PIPE/OUT

DUCT (HIGH STATIC) INDOOR UNITS

Wiring Diagrams

MULTI F
MULTI F MAX

Figure 132: Multi F Ceiling-Concealed Duct (High Static) LMHN240HV Indoor Units Wiring Diagram.

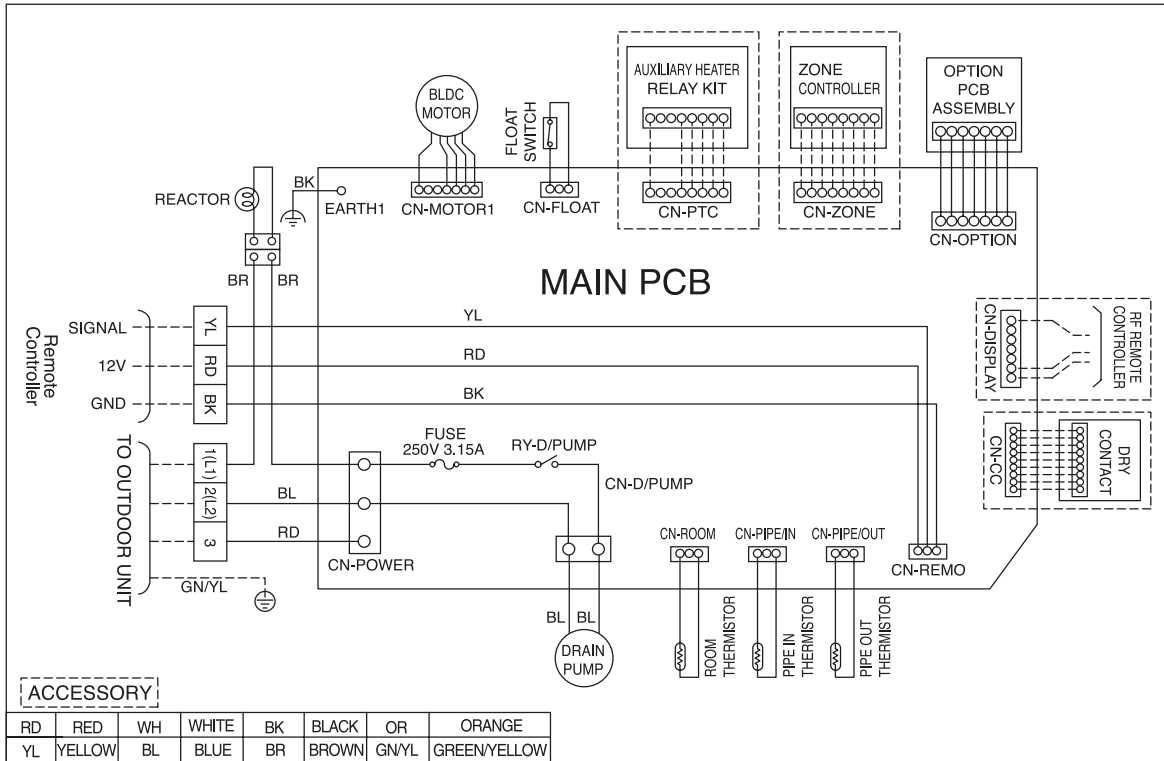
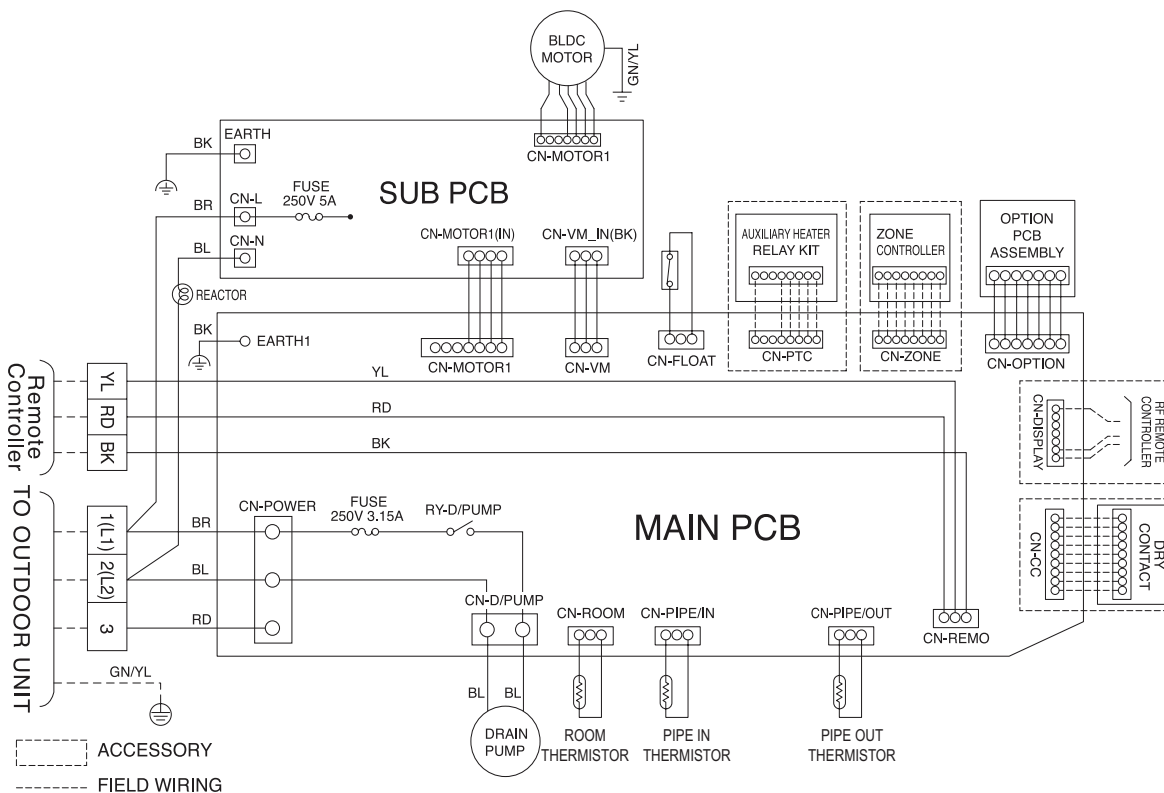
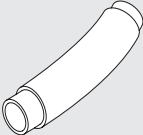
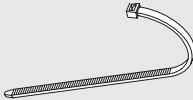

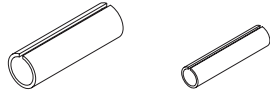
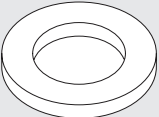



Figure 133: Multi F Ceiling-Concealed Duct (High Static) LMHN360HV Indoor Units Wiring Diagram.



Factory Supplied Parts

Table 56: Parts Table.

Part	Quantity	Image	Part	Quantity	Image
Drain Hose	One (1)		Zip Ties	Four (4)	
Metal Clamp	Two (2)		Insulation for Fittings	One (1) Set	 For Vapor Piping For Liquid Piping
Washers for Hanging Brackets	Eight (8)		Simple Controller with Mode Selection (AKB72955816) ¹	One (1)	

¹Simple Mode Controllers for the ceiling-concealed duct (high static) indoor units are also referenced by Model No. PQRCVCL0QW.

Factory Supplied Materials

- Owner's Manual
- Installation Manual

Required Tools

- Level
- Screwdriver
- Electric drill
- Hole core drill
- Flaring tool set
- Torque wrenches
- Hexagonal wrench
- Gas-leak detector
- Thermometer

⚠ WARNING

Installation work must be performed by trained personnel and in accordance with national wiring standards and all local or other applicable codes. Improper installation can result in fire, electric shock, physical injury, or death.

Note:





Read all instructions before installing this product. Become familiar with the unit's components and connections, and the order of installation. Incorrect installation can degrade or prevent proper operation.

Selecting the Best Location

Do's

- Place the unit where air circulation will not be blocked.
- Place the unit where drainage can be obtained easily.
- Place the unit where noise prevention is taken into consideration.
- Ensure there is sufficient strength to bear the load of the indoor unit.
- Ensure there is sufficient maintenance space.
- Locate the indoor unit in a location that is level, and where it can be easily connected to the outdoor unit / branch distribution unit.

Don'ts

-  Do not install the unit near a heat or steam source, or where considerable amounts of oil, iron powder, or flour are used.
-  Do not install the unit where sulfuric acid and flammable or corrosive gases are generated, vented into, or stored.
-  Do not install the unit near high-frequency generators.
-  Do not install the unit near a doorway.

The unit may be damaged, may malfunction, and / or will not operate as designed if installed in any of the conditions listed.

DUCT (HIGH STATIC) INDOOR UNITS

Installation and Best Layout Practices

MULTI F
MULTI F MAX

Note:

If the unit is installed near a body of water, certain components are at risk of being corroded. Appropriate anti-corrosion methods should be taken for the unit and all components.

Installing in an Area Exposed to Unconditioned Air

In some installation applications, areas (floors, walls) in some rooms may be exposed to unconditioned air (room may be above or next to an unheated garage or storeroom). To countermeasure:

- Verify that carpet is or will be installed (carpet may increase the temperature by three degrees).
- Add insulation between the floor joists.
- Install radiant heat or another type of heating system to the floor.

Installing in an Area with High Humidity Levels

If the environment is prone to humidity levels of 80% or more (near the ocean, lakes, etc.) or where steam could collect in the plenum:

- Install additional insulation to the indoor unit (glass wool insulation >13/32 inches thick).
- Install additional insulation to the refrigerant piping (insulation >13/16 inches thick).
- Seal all gaps between the indoor unit and the ceiling tiles (make the area air tight) so that humidity does not transfer from the plenum to the conditioned space. Also, add a ceiling grille for ventilation.

Figure 134: Access Panel and General Service Space Required Dimensions.

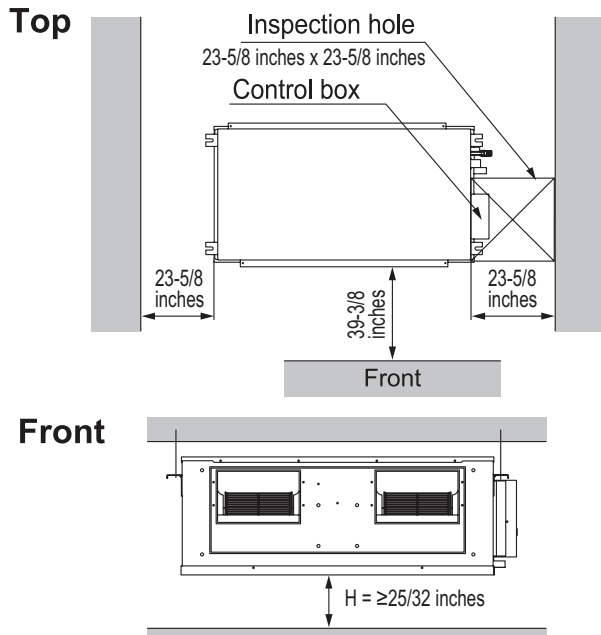

Figure 135: Indoor Unit Bolt Locations.

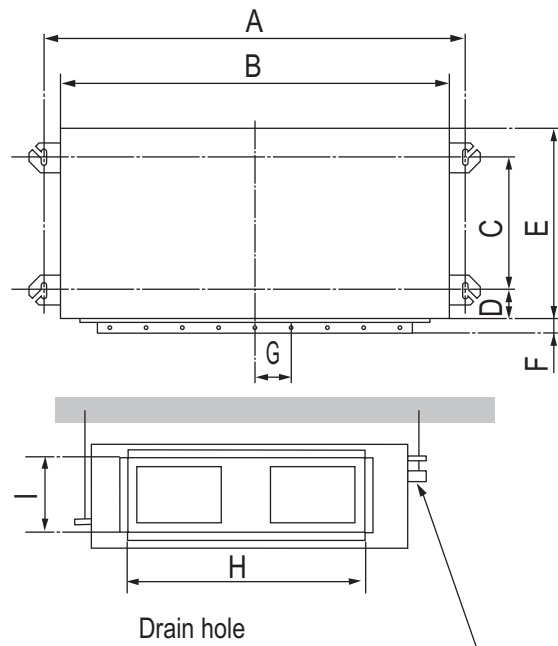

Table 57: Indoor Unit Bolt Location Dimensions.

Model / Capacity (Btu/h)	Dimensions (inches)								
	A	B	C	D	E	F	G	H	I
LMHN240HV / 24,000	48-17/32	46-17/32	13-31/32	1-25/32	17-23/32	1-7/32	3-5/8	32-19/32	7-11/32
LMHN360HV / 36,000									

Preparing the Installation Area and Hanging the Indoor Unit Frame

1. Select and mark the area for the suspension or console bolts (use embedded inserts or anchor bolts in new buildings, and hole-in-anchors in older buildings).
2. Drill the holes.
3. Add the set-anchor and the plate washer to the bolts (bolts should be at least 13/32 inches in diameter), and then insert the bolts into the installation area.
4. Add the plate washer, spring washer, and nut to secure the bolts into the installation area.
5. Position the indoor unit installation plates onto the bolts. Secure using nuts, plate washers, and spring washers. Adjust for level as necessary.

Figure 136: Preparing the Installation Area.

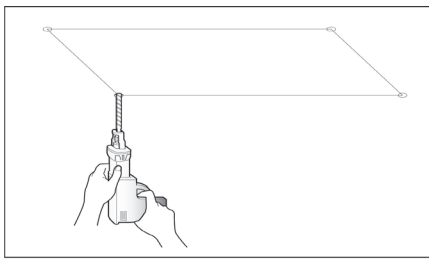

Figure 137: Suspension Bolt Options.

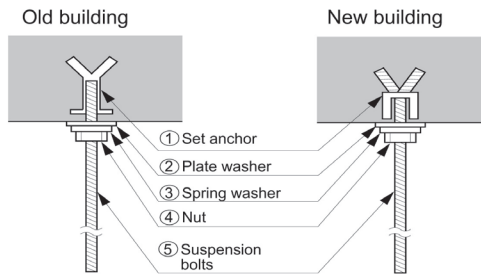
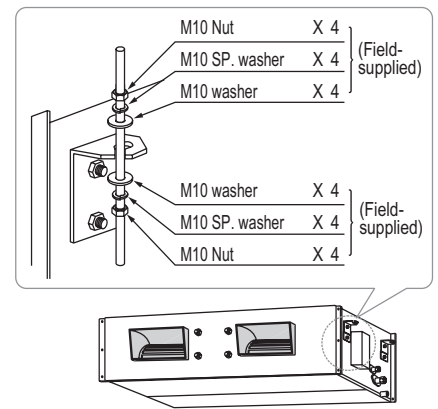

Figure 138: Hanging the Indoor Unit.



Note:

Install a canvas duct to the air outlet and air inlet so that vibration from the indoor unit does not carry to the duct or ceiling. Also, add insulation to the interior of the duct, and apply anti-vibration to the suspension bolts.

⚠ WARNING

- Unit must be installed correctly. Tighten the nuts and bolts to prevent the unit from falling and causing severe injury or death.

Installing the Drain System

- Drain piping must have downward gradient of at least 1/50 to 1/100; to prevent reverse flow, slope should not be straight up and down.
- Do not damage the drain port on the indoor unit when connecting the field-supplied drain piping.
- Drain piping specifications:
 - Indoor Unit Drain Connection: 1-1/4 inch outside diameter.
 - Field-Supplied Drain Piping: Polyvinyl chloride piping with 1-inch inside diameter and pipe fittings.

Figure 140: Drain Piping Installation Dimensions.

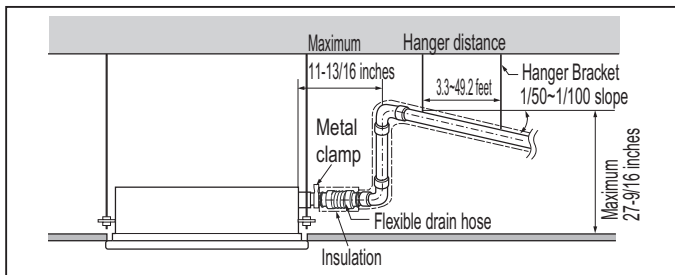
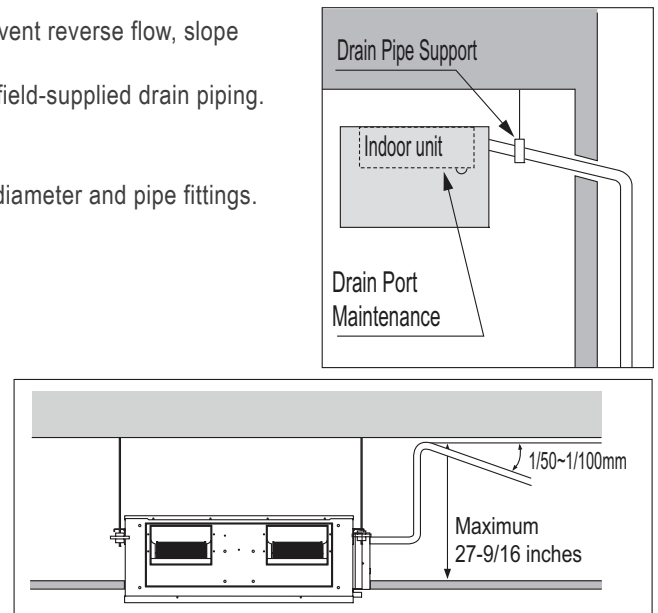

Figure 139: Indoor Unit Drain Piping.



Note:

Do not apply force or twist the drain hose: it may leak.

DUCT (HIGH STATIC) INDOOR UNITS

Installation and Best Layout Practices

MULTI F
MULTI F MAX

Checking the Drain Pump

The unit uses a drain pump to remove condensate. The pump must be tested before the system operates.

- Connect (field supplied) flexible drain hose to the field-installed drain piping; leave it as is until the test is complete.
- Pour water into the flexible drain hose and check for leaks.
- After power wiring installation is complete, operate the drain pump to see if it sounds and functions properly.
- After the test is complete, connect the flexible drain hose to the indoor unit drain port.

Figure 141: Checking the drain pump.

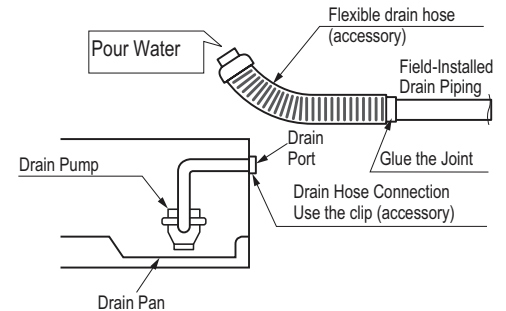

Checking the Drainage System

1. Remove the air filter.
2. Check the drainage.
 - Spray water on the evaporator.
 - Verify that water flows through the indoor unit drain hose without leaking.

Figure 142: Checking the Drainage System.

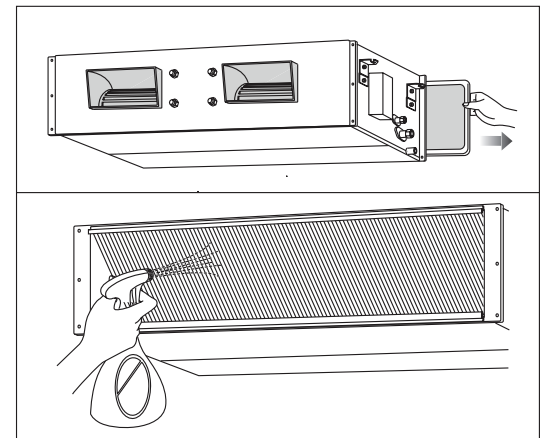

Insulating the Refrigerant and Drain Piping

⚠ WARNING

Ensure all piping is insulated. Exposed piping can cause burns if touched.

Refrigerant Piping Insulation

Field-installed vapor and liquid refrigerant piping lines must be properly and completely covered in insulation (up to the indoor unit piping connections). Any exposed piping may generate condensate or will cause burns if touched. Insulation for this field-installed refrigerant piping must have a minimum heat resistance of 248°F.

Drain Piping Insulation

Drain piping must have insulation a minimum of 7/32 inches thick.

Figure 143: Insulating the Piping.

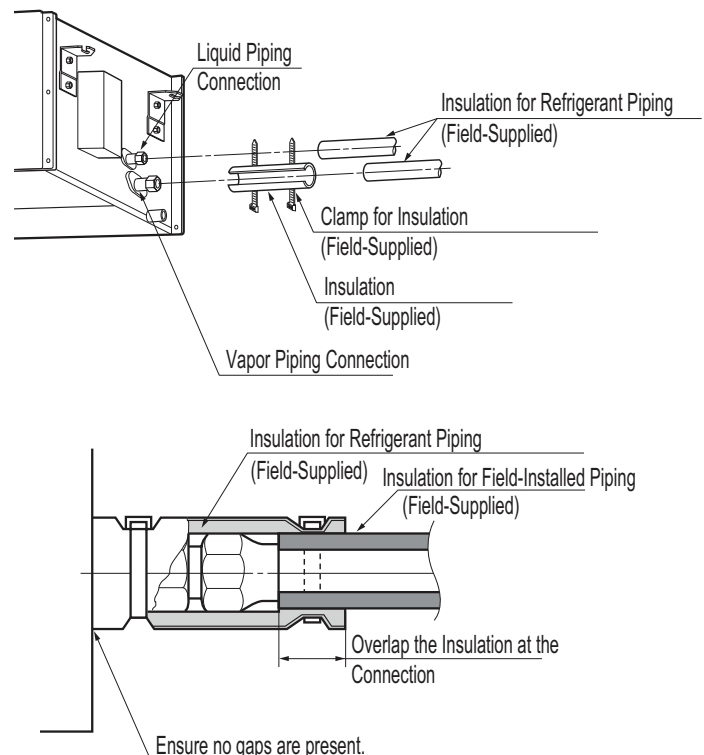

Power Wiring / Communications Cable Guidelines

- Follow manufacturer's circuit diagrams in the technical manuals.
- Confirm power source specifications.
- Confirm that the electrical capacity is sufficient.
- Starting current must be maintained ± 10 percent of the rated current marked on the outdoor unit name plate.
- Confirm cable thickness specifications.
- It is recommended that a circuit breaker is installed, especially if conditions could become wet or moist.
- Include a disconnect in the power wiring system, add an air gap contact separation of at least 1/8 inch in each active (phase) conductor.

⚠ WARNING

• Loose wiring may cause unit to malfunction, overheat, and catch fire, resulting in severe injury or death.

Note:

- Terminal screws may become loose during transport. Properly tighten the terminal connections during installation.
- A voltage drop may cause the following problems:
- Magnetic switch vibration, fuse breaks, or disturbance to the normal function of an overload protection device.
 - Compressor will not receive the proper starting current.

Connecting the Power Wiring and Communications Cable

1. To access the terminal block, first unscrew the cover from the control box.
2. Insert the power wiring / communications cable from the outdoor unit or branch distribution unit (Multi F MAX systems only) through the sides of the indoor unit and control box. Pass the wiring through the designated access holes to prevent damage. To prevent electromagnetic interference and product malfunction, leave a space between the power wiring and communications cable outside of the indoor unit.
3. Connect each wire to its appropriate terminal on the indoor unit control board. Verify that the color and terminal numbers from the outdoor unit or branch distribution unit (Multi F MAX systems only) wiring match the color and terminal numbers on the indoor unit.
4. Secure the power wiring / communications cable with the cable restraint.
5. Screw the steel clamp to the inside of the control panel.
 - Place the wiring / cables in the clamp and tighten the plastic clamp to an open surface of the control panel.
 - When clamping, do not apply force to the wiring connections.
 - Neatly arrange the wiring, do not catch the wiring in the electric box cover, and ensure the cover firmly closes.
6. Fill in any gaps around the wiring access holes with sealant to prevent foreign particles from entering the indoor unit.

Figure 144: Accessing the Indoor Unit Terminal Block.

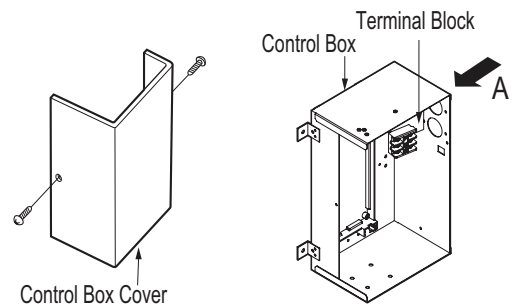
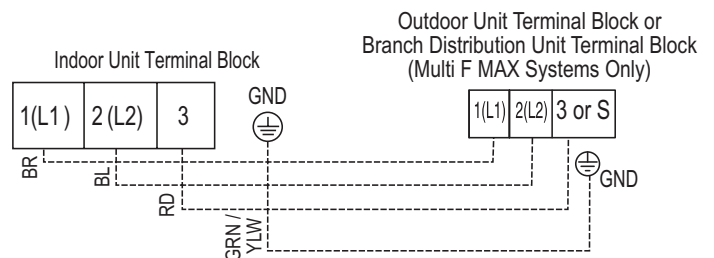

Figure 145: Indoor Unit to Outdoor Unit / Branch Distribution Unit (Multi F MAX systems only) Power Wiring / Communications Cable Connections.



DUCT (HIGH STATIC) INDOOR UNITS

Installation and Best Layout Practices

MULTI F
MULTI F MAX

Using a Conduit

1. Remove the rubber stopper on the indoor unit. Pass the power wiring / communications cable through the conduit, the conduit mounting plate, and to / through the control panel of the indoor unit.
2. Connect the power wiring / communications cable to the indoor unit terminal block.
3. Screw the conduit mounting plate to the indoor unit.
4. Tighten the conduit and the conduit mounting plate together.

Note:

If the distance between the outdoor unit and indoor unit is greater than 131 feet, connect the power wiring and communications cable separately (i.e., a conduit cannot be used).

Controller Options

Ceiling-concealed duct (high static) indoor units include an LG-supplied wired controller (AKB72955816)¹, but other optional LG-supplied wired controllers are available. The wireless handheld controller (Model No. PQWRHQ0FDB) is also an optional accessory with use of the wired controller.

- Operation Display Panel: Displays operation conditions.
- Temperature Control Button: Sets desired temperature.
- Fan Speed Button: Sets desired fan speed.
- On / Off Button: Turns system operation on and off.
- Mode Selection Check Button: Selects the operation mode: Cooling, Heating, Auto, Dry (Dehumidification), or Fan.

Note:

Each function will display on the LED for about three (3) seconds when the power is first cycled on.

¹Simple Mode Controllers for the ceiling-concealed duct (high static) indoor units are also referenced by Model No. PQRCVCL0QW.

Wired Controller Connections

Controllers can connect to the indoor unit in one of two different ways.

1. LG Wired Remote Extension Cable with Molex plug (PZCWRC1; sold separately) that connects to the CN-REMO terminal on the indoor unit PCB.
2. Field-supplied controller cable that connects to the indoor unit terminal block (must be at least UL2547 or UL1007, 22 AWG, two-core, one-shield core, at least FT-6 rated if local electric and building codes require plenum cable usage).

Note:

When using field-supplied controller cable, make sure to connect the yellow to yellow (communications wire), red to red (12V power wire), and black to black (ground wire) terminals from the remote controller to the indoor unit terminal blocks.

Figure 146: Exterior View of Conduit Installation.

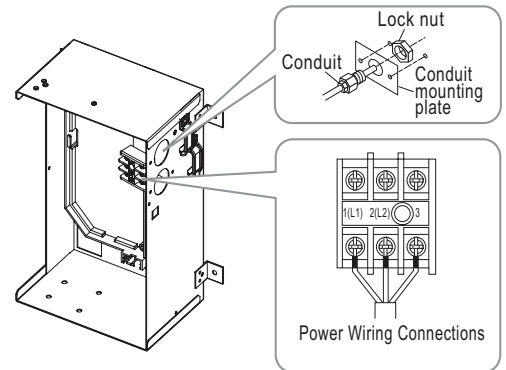

Wired Controller

Figure 147: AKB72955816¹ Wired Controller.

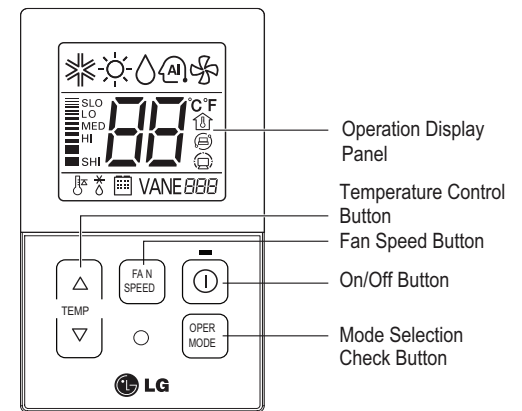

Figure 148: PZCWRC1 LG Wired Remote Extension Cable.

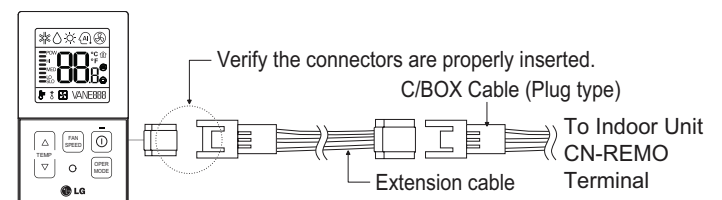
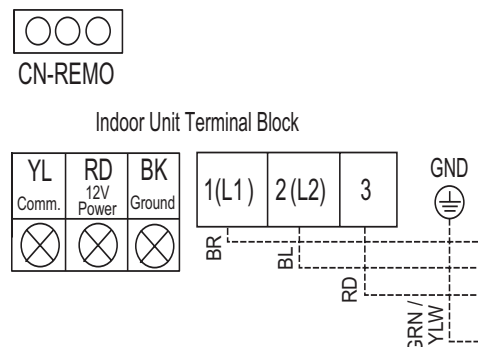

Figure 149: Wired Controller Connections on the Indoor Unit Terminal Block.



Wired Controller Placement

Wired controllers include a sensor to detect room temperature. To maintain comfort levels in the conditioned space, the wired controller must be installed in a location away from direct sunlight, high humidity, and where it could be directly exposed to cold air. Controller must be installed four (4) to five (5) feet above the floor where its LED display can be read easily, in an area with good air circulation, and where it can detect an average room temperature.

- ⊘ Do not install the wired controller near or in:
 - Drafts or dead spots behind doors and in corners
 - Hot or cold air from ducts
 - Radiant heat from the sun or appliances
 - Concealed pipes and chimneys
 - An area where temperatures are uncontrolled, such as an outside wall

Figure 150: Proper Location for the Wired Controller.

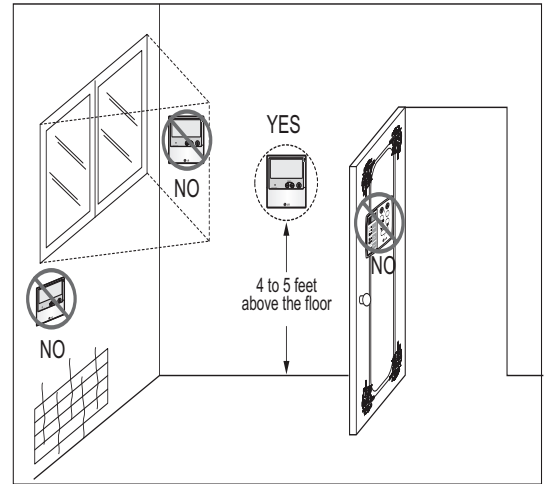

Hanging the Wired Controller

1. The controller wiring / cable can be installed in one of three directions: top, back, or on the right side. If top or right side installation is desired, remove cable guide grooves on the controller, and then position wiring / cable on applicable side.
2. Choose and mark the area of installation, and then screw the wall plate into place (using the provided parts). Install the controller wall plate to fit the electrical box if one is present. Ensure that no gaps exist between the wall plate and the wall itself.
3. Arrange wiring / cables so as not to interfere with the controller circuitry. Position the wired controller on the wall plate. Snap into place by pressing the bottom part of the wired controller onto the wall plate. Make sure that no gaps exist between the wired controller and the wall plate on all sides.
4. To remove wired controller from the wall plate, insert a screwdriver into the two holes at the bottom. Twist screwdriver to release controller. Do not damage the controller components when removing.

Figure 151: Removing the Cable Guide Grooves.

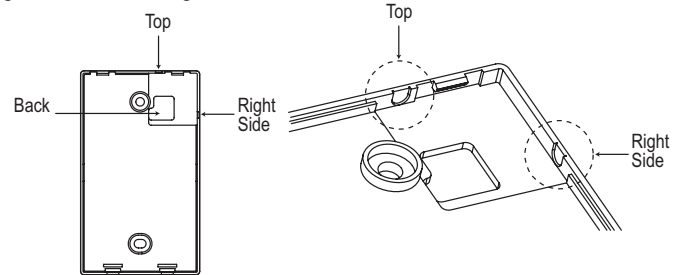

Figure 152: Attaching the Wall Plate.

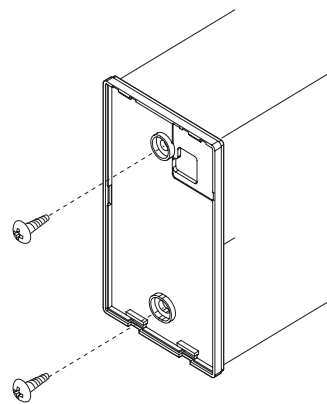
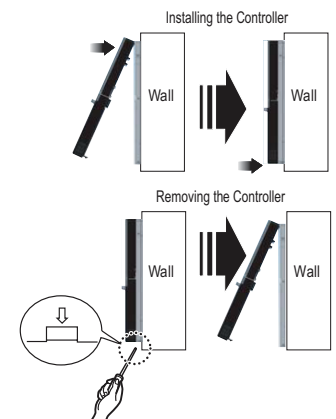

Figure 153: Installing / Removing the Controller.



Assigning the Thermistor for Temperature Detection

Each indoor unit includes a return air thermistor assigned to sense the temperature. If a wired controller is installed, there is a choice of sensing temperature with either the indoor unit return air thermistor or the thermistor in the wired controller. It is also an option to set both thermistors to sense temperature so that indoor unit bases its operation on the first thermistor to reach the designated temperature differential. For applicable indoor units, an optional Remote Temperature Sensor can be used in lieu of the return air thermistor—either alone or in conjunction with a wired controller thermistor as previously described.

DUCT (HIGH STATIC) INDOOR UNITS

Installation and Best Layout Practices

MULTI F
MULTI F MAX

External Static Pressure Control

To provide a required air flow rate that accounts for the external static pressure change, follow the steps below.

1. To access system installer setting mode, press and hold the temperature increase and mode selection buttons simultaneously for approximately three (3) seconds. Choose setting code value "06" by pressing the mode selection button.

2. Use the temperature increase and decrease buttons to select the desired setting value.

Setting Values

- 01 : V-H
- 02 : F-H
- 03 : V-L
- 04 : F-L

3. Press the on / off button to save the established settings.

4. To deactivate system installer setting mode after the settings have been established, press and hold the temperature increase and mode selection check buttons simultaneously for approximately three (3) seconds. If a button is not pressed for more than 25 seconds, the system installer setting mode will automatically deactivate.

Figure 154: Select Code and Set Value.

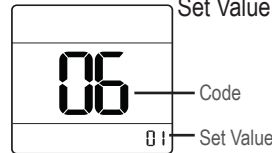

Figure 155: Controller External Static Pressure Setting Display.

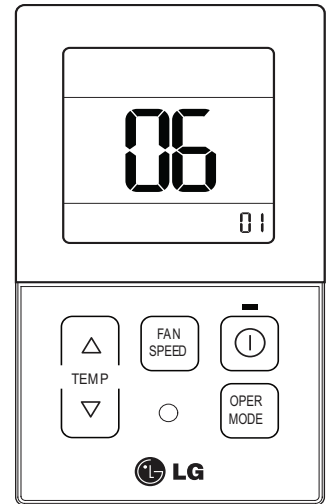

Table 64: Static Pressure Setting Table.

Pressure Selection		Function	
		Zone State	External Static Pressure Standard Value
01	V-H	Variable	High
02	F-H	Fixed	High
03	V-L	Variable	Low
04	F-L	Fixed	Low

Note:

- Select the position after verifying duct work and the external static pressure of the indoor unit.
- Factory set to pressure selection F-H.

Assigning Air Flow

To assign an air flow for each fan speed, follow the steps below.

1. To access system installer setting mode, press and hold the temperature increase and mode selection buttons simultaneously for approximately three (3) seconds. Choose setting code value "03" by pressing the mode selection button.
2. Use the fan speed button to select the desired fan speed. (Lo→Med→Hi will display on the LED).
3. Use the temperature increase and decrease buttons to select the desired external static pressure setting value (thereby assigning the respective airflow). External static pressure value range: 0~255; the value will display near the lower right corner of the LED.
4. Press the on / off button to save the established settings.
5. To deactivate system installer setting mode after the settings have been established, press and hold the temperature increase and mode selection check buttons simultaneously for approximately three (3) seconds. If a button is not pressed for more than 25 seconds, the system installer setting mode will automatically deactivate.

Figure 156: Controller External Static Pressure Setting Display.

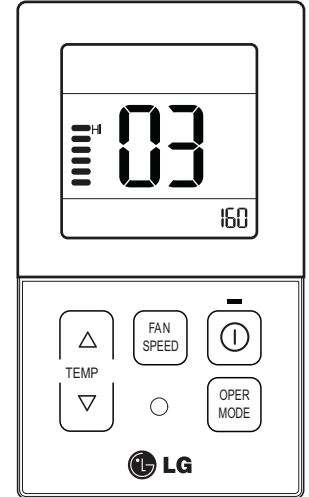

Note:

- A certified technician must set the external static pressure value(s). If the external static pressure is set incorrectly, the system may malfunction.
- Do not alter the external static pressure value that corresponds to each air flow level.
- External static pressure value can vary depending on the indoor unit.
- If by pressing the fan speed button during external static pressure setup, the fan speed is raised to the next level, the air flow value of the previous fan speed will be maintained (external static pressure setting value is saved).

FOUR-WAY CEILING-CASSETTE INDOOR UNIT DATA

“Mechanical Specifications” on page 113

“General Data / Specifications” on page 114

“Dimensions” on page 115

“Cooling Capacity Table” on page 117

“Heating Capacity Table” on page 120

“Acoustic Data” on page 121

“Air Velocity and Temperature Distribution” on page 123

“Refrigerant Flow Diagram” on page 125

“Wiring Diagram” on page 126

“Factory Supplied Parts and Materials” on page 127

“Installation and Best Layout Practices” on page 128

MULTI F FOUR-WAY CEILING CASSETTE INDOOR UNITS

MULTI F MAX Mechanical Specifications and Features

Four-Way Ceiling-Cassette Indoor Units

General

All LG indoor units are factory assembled, wired, piped, and provided with a control circuit board, fan, and motor. Four-way ceiling-cassette units have a sound rating no higher than 38 dB(A) as tested per KSA0701 ISO Standard 3745.

Coil

Indoor unit coils are factory built and are comprised of aluminum fins mechanically bonded to copper tubing. Each unit has two rows of coils, which are pressure tested at the factory. Each unit is provided with a factory installed condensate drain pan below the coil.

Refrigerant System

System is designed for use with R410A refrigerant. The refrigeration circuit is pressure-tested at the factory and shipped with a holding charge of helium gas. Refrigerant pipe connections are 45° flare, and all refrigerant lines from the outdoor unit to the indoor units must be field insulated.

Electrical

Each indoor unit is designed to operate using 208–230/60/1 power with voltage variances of ±10%.

Casing

The case is constructed of a galvanized steel plate designed to recess in the ceiling, and has a surface mounted concentric grille on the bottom of the unit. Unit has four supply air outlets and one return air inlet.

Ventilation Air

The case has a factory designated knockouts to connect a field-supplied, pressurized, and filtered outside air duct.

Fan Assembly and Control

All indoor units have a single, direct-drive turbo fan. Fans are manufactured of high-strength ABS HT-700 polymeric resin that is statically and dynamically balanced. The fan motor is brushless digitally controlled (BLDC) with permanently lubricated and sealed ball bearings. The fan / motor assembly is mounted on vibration-attenuating rubber grommets. Fan speed is controlled using a microprocessor-based direct digital control algorithm that provides pre-programmed, field-selectable fixed or auto fan speeds in the Heating and Cooling modes.

The indoor fan has Low, Med, High, Power Cool and Auto settings for Cooling mode; and has Low, Med, High, and Auto settings for Heating mode. Auto setting adjusts the fan speed based on the difference between the controller setpoint and space temperature.

Air Filter

Return air is filtered with a factory-supplied, removable, washable

Features

- Inverter (Variable speed fan)
- Internal drain pump
- Jet cool
- Control lock function
- Auto operation
- Auto restart operation
- 24-Hour on/off timer
- Two thermistor control
- Required accessory grille (PT-QCHW0 or PT-UQC) sold separately
- Group Control
- Plasma kit (PTPKQ0) sold separately
- Wireless LCD remote control included; wired thermostat available (sold separately)

filter accessible from the bottom of the unit. A plasma filter is also available as an optional accessory.

Architectural Grille

An architectural grille is sold as a separate required accessory. The four-way grille is off-white acrylonitrile butadiene styrene (ABS) polymeric resin with a tapered trim edge.

Airflow Guide Vanes

The supply air outlet has four-directional slot diffusers, each equipped with an independent oscillating motorized guide vane to change airflow direction. A guide vane algorithm sequentially changes the predominant discharge airflow direction in counterclockwise pattern, or can be used to lock each guide vane independently in a field-adjusted fixed position. The four vanes can be individually adjusted from the wired remote controller to customize the airflow pattern for the conditioned space. A setting in the cooling and heating modes can cycle the vanes up and down for uniform / random air distribution.

Microprocessor Control

The indoor unit is provided with an integrated control panel to communicate with the outdoor unit. All unit operation parameters are stored in non-volatile memory residing on the unit microprocessor. The microprocessor controls space temperature through using the value provided by the temperature sensor within the indoor unit. The microprocessor control will activate indoor unit operation when the indoor room temperature falls below or rises above a setpoint temperature, at which point, a signal is sent to the outdoor unit to begin the appropriate mode. The microprocessor will also provide self-diagnostics and auto restart functions. A field-supplied four-wire power / communications cable must be installed to connect the indoor unit(s) to the outdoor unit.

Controls

The indoor unit casing has a factory-standard, integral infrared sensor designed to communicate with the supplied LG wireless handheld remote controller. An optional wired controller is available as an additional accessory. Communication between the indoor units and the outdoor unit is accomplished through 18 AWG, four-core, stranded and shielded power / communication cable.

Condensate Lift/Pump

The indoor unit is provided with a factory installed and wired internal condensate lift/pump capable of providing a minimum 27.5 inch lift from the bottom surface of the unit. Drain pump has a safety switch to shut off the indoor unit if the condensate rises too high in the drain pan.

Figure 157: Multi F Four-Way Ceiling-Cassette Indoor Unit.



FOUR-WAY CEILING-CASSETTE INDOOR UNITS **MULTI F** **MULTI F MAX**

General Data / Specifications

Table 65: Multi F Four-Way Ceiling-Cassette Indoor Unit General Data.

Model Name	LMCN077HV	LCN097HV4	LCN127HV4	LMCN185HV
Grille (Sold Separately)	PT-QCHW0 / PT-UQC	PT-QCHW0 / PT-UQC	PT-QCHW0 / PT-UQC	PT-QCHW0 / PT-UQC
Nominal Cooling Capacity (Btu/h) ¹	7,000	9,000	12,000	18,000
Nominal Heating Capacity (Btu/h) ¹	8,100	10,400	13,800	20,800
Operating Range				
Cooling (°F WB)	57-77			
Heating (°F DB)	59-81			
Fan				
Type	Turbo			
Motor Output (W) x Qty.	43 x 1			
Motor/Drive	Brushless Digitally Controlled / Direct			
Airflow Rate CFM (H/M/L)	265 / 212 / 177	300 / 265 / 230	335 / 283 / 247	459 / 424 / 388
Unit Data				
Refrigerant Type ²	R410A			
Refrigerant Control	EEV			
Power Supply V, Ø, Hz ³	208-230, 1, 60			
Rated Amps (A)	0.25			
Sound Pressure Level ±3 dB(A) (H/M/L) ⁴	31 / 27 / 24	36 / 33 / 30	38 / 35 / 32	38 / 37 / 34
Body Dimensions (W x H x D, in.)	22-7/16 x 8-7/16 x 22-7/16			22-7/16 x 10-3/32 x 22-7/16
Grille (Sold separately) Dimensions (WxHxD, in.)	27-9/16 x 7/8 x 27-9/16			
Body Net Weight (lbs.)	31			34
Grille (Sold separately) Net Weight (lbs.)	7			
Body Shipping Weight (lbs.)	34	37		42
Grille (Sold separately) Shipping Weight (lbs.)	11	9	9	11
Power Wiring / Communications Cable (No. x AWG) ⁵	4 x 18			
Heat Exchanger (Row x Column x Fin / inch) x Number	(2 x 8 x 18) x 1			(2 x 10 x 18) x 1
Piping				
Liquid (in.)	1/4			
Vapor (in.)	3/8			1/2
Drain O.D. / I.D. (in.)	1-1/4, 1			

¹Nominal capacity is rated 0 ft. above sea level with a 0 ft. level difference between outdoor and indoor units. All capacities are net with a combination ratio between 95 – 105%.

Nominal cooling capacity rating obtained with air entering the indoor unit at 80°F dry bulb (DB) and 67°F wet bulb (WB) and outdoor ambient conditions of 95°F dry bulb (DB) and 75°F wet bulb (WB).
Nominal heating capacity rating obtained with air entering the indoor unit at 70°F dry bulb (DB) and 60°F wet bulb (WB) and outdoor ambient conditions of 47°F dry bulb (DB) and 43°F wet bulb (WB).

²This unit comes with a dry helium charge.

³Acceptable operating voltage: 187V-253V.

⁴Sound pressure levels are tested in an anechoic chamber under ISO Standard 3745 and are the same in both cooling and heating mode. These values can increase due to ambient conditions during operation.

⁵All power wiring / communications cable to the IDUs be minimum 18 AWG, 4-conductor, stranded, shielded or unshielded (if shielded, must be grounded to chassis at ODU only) and must comply with applicable local and national codes.

MULTI F FOUR-WAY CEILING CASSETTE INDOOR UNITS

MULTI F MAX

Dimensions

Figure 158: LMCN077HV, LCN097HV4, and LCN127HV4 Dimensions.

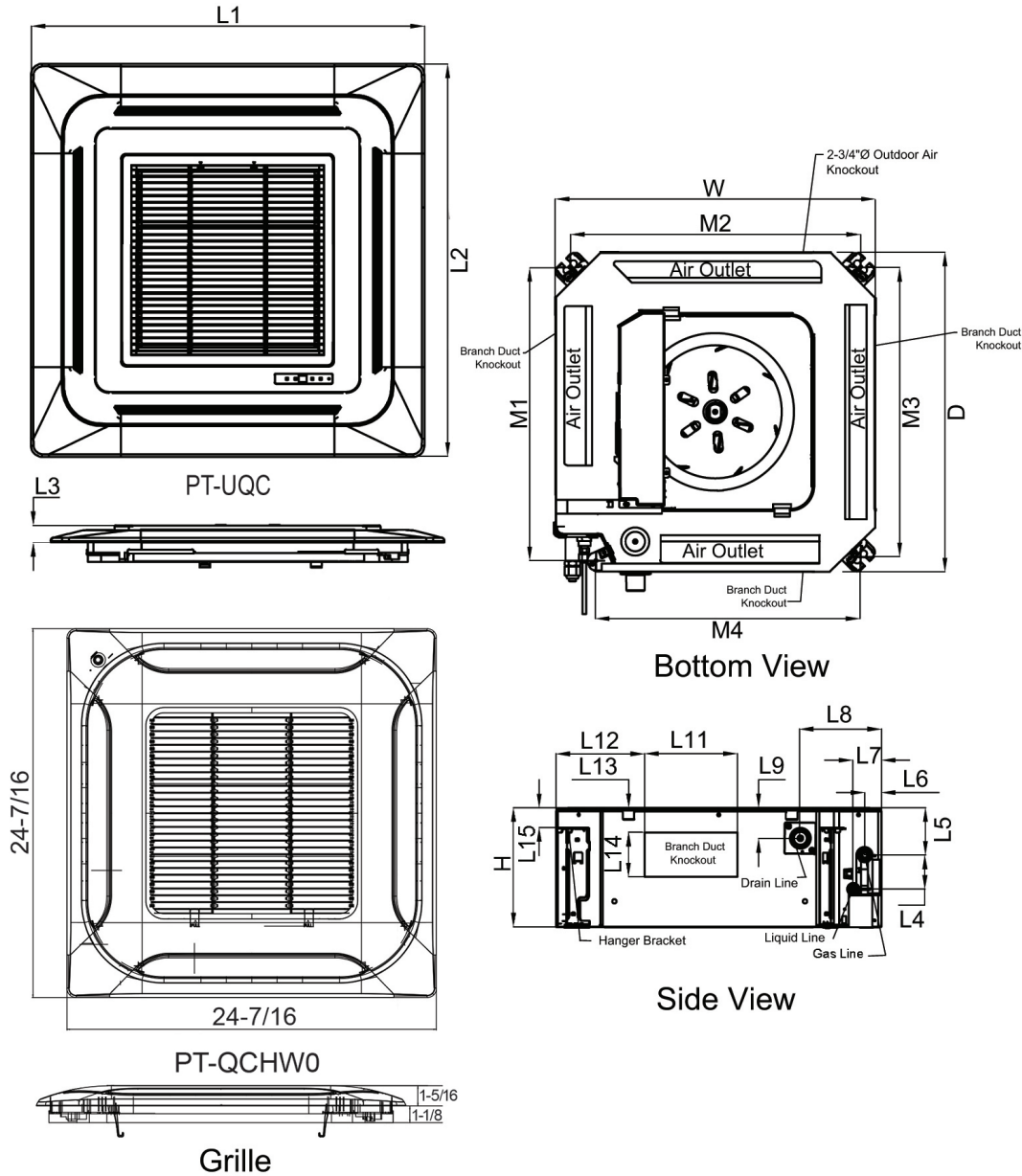

W	22-7/16"
H	8-7/16"
D	22-7/16"
L1	27-9/16"
L2	27-9/16"
L3	7/8"
L4	2-13/32"
L5	3-7/8"
L6	1-3/16"
L7	1-15/16"
L8	5-5/8"
L9	1-1/32"
L10	1-11/32"
L11	6-1/2"
L12	5-13/16"
L13	3-3/16"
L14	3-1/8"
L15	1-11/32"
M1	20-19/32"
M2	20-3/8"
M3	20-3/8"
M4	18-5/32"

Four-Way Ceiling-Cassette

MULTI F FOUR-WAY CEILING CASSETTE INDOOR UNITS

MULTI F MAX

Cooling Capacity Table

Table 66: Multi F Four-Way Ceiling-Cassette Indoor Units Cooling Capacity Table.

Model No. / Nominal Capacity of Indoor Unit (Btu/h)	Outdoor Air Temp. (°F DB)	Indoor Air Temp. °F DB / °F WB											
		68 / 57		73 / 61		77 / 64		80 / 67		86 / 72		90 / 75	
		TC	SHC	TC	SHC	TC	SHC	TC	SHC	TC	SHC	TC	SHC
LMCN077HV 7,000	14	6.86	4.87	7.29	5.15	7.71	4.99	8.02	5.09	8.57	5.13	8.99	5.23
	20	6.86	4.91	7.28	5.19	7.71	5.02	8.02	5.13	8.56	5.17	8.99	5.27
	25	6.85	4.95	7.28	5.23	7.70	5.06	8.01	5.17	8.55	5.21	8.98	5.31
	30	6.85	4.99	7.27	5.27	7.70	5.10	8.00	5.21	8.55	5.25	8.97	5.35
	35	6.84	5.03	7.27	5.31	7.69	5.14	8.00	5.25	8.54	5.29	8.97	5.39
	40	6.84	5.06	7.26	5.35	7.68	5.18	7.99	5.29	8.53	5.33	8.96	5.43
	45	6.83	5.10	7.25	5.39	7.68	5.22	7.99	5.33	8.53	5.37	8.95	5.47
	50	6.83	5.14	7.25	5.43	7.67	5.26	7.98	5.37	8.52	5.41	8.94	5.52
	55	6.82	5.18	7.24	5.47	7.67	5.30	7.97	5.41	8.51	5.45	8.94	5.56
	60	6.81	5.21	7.24	5.51	7.66	5.33	7.97	5.45	8.51	5.49	8.93	5.60
	65	6.81	5.25	7.23	5.55	7.66	5.37	7.96	5.49	8.50	5.53	8.92	5.64
	70	6.80	5.29	7.23	5.59	7.65	5.41	7.95	5.52	8.49	5.57	8.92	5.68
	75	6.64	5.20	7.06	5.50	7.48	5.33	7.79	5.45	8.33	5.50	8.75	5.61
	80	6.48	5.11	6.90	5.42	7.32	5.26	7.62	5.38	8.16	5.43	8.58	5.55
	85	6.31	5.02	6.73	5.33	7.15	5.17	7.46	5.30	7.99	5.36	8.41	5.48
	90	6.15	4.93	6.57	5.23	6.99	5.09	7.29	5.21	7.83	5.29	8.24	5.40
	95	5.98	4.87	6.39	5.19	6.81	5.05	7.00	5.10	7.64	5.26	8.06	5.38
	100	5.83	4.74	6.25	5.05	6.66	4.93	6.91	5.02	7.50	5.14	7.91	5.27
	105	5.69	4.61	6.10	4.92	6.52	4.81	6.82	4.94	7.35	5.03	7.77	5.16
	110	5.54	4.46	5.96	4.76	6.37	4.66	6.67	4.79	7.21	4.89	7.62	5.02
115	5.39	4.32	5.81	4.63	6.23	4.54	6.53	4.67	7.06	4.77	7.48	4.90	
118	5.31	4.29	5.72	4.60	6.14	4.52	6.44	4.65	6.97	4.76	7.39	4.89	
122	5.28	4.28	5.69	4.59	6.11	4.51	6.41	4.64	6.94	4.75	7.36	4.89	
LCN097HV4 9,000	14	8.82	6.31	9.37	6.66	9.92	6.45	10.31	6.59	11.01	6.64	11.56	6.77
	20	8.82	6.36	9.36	6.72	9.91	6.50	10.31	6.64	11.01	6.70	11.55	6.82
	25	8.81	6.41	9.36	6.77	9.90	6.55	10.30	6.69	11.00	6.75	11.54	6.87
	30	8.80	6.46	9.35	6.82	9.90	6.60	10.29	6.74	10.99	6.80	11.54	6.93
	35	8.80	6.50	9.34	6.87	9.89	6.65	10.28	6.79	10.98	6.85	11.53	6.98
	40	8.79	6.55	9.33	6.92	9.88	6.70	10.27	6.84	10.97	6.90	11.52	7.03
	45	8.78	6.60	9.33	6.97	9.87	6.75	10.27	6.90	10.96	6.95	11.51	7.09
	50	8.78	6.65	9.32	7.03	9.87	6.80	10.26	6.95	10.96	7.00	11.50	7.14
	55	8.77	6.70	9.31	7.08	9.86	6.85	10.25	7.00	10.95	7.06	11.49	7.19
	60	8.76	6.75	9.31	7.13	9.85	6.90	10.24	7.05	10.94	7.11	11.48	7.24
	65	8.76	6.80	9.30	7.18	9.84	6.95	10.24	7.10	10.93	7.16	11.47	7.29
	70	8.75	6.85	9.29	7.23	9.84	7.00	10.23	7.15	10.92	7.21	11.47	7.35
	75	8.54	6.73	9.08	7.12	9.62	6.90	10.01	7.05	10.71	7.12	11.25	7.26
	80	8.33	6.62	8.87	7.01	9.41	6.80	9.80	6.96	10.49	7.03	11.03	7.18
	85	8.12	6.50	8.66	6.89	9.20	6.70	9.59	6.85	10.28	6.94	10.82	7.09
	90	7.91	6.37	8.45	6.77	8.99	6.59	9.37	6.75	10.06	6.84	10.60	6.99
	95	7.68	6.31	8.22	6.71	8.75	6.54	9.00	6.60	9.83	6.80	10.36	6.96
	100	7.50	6.14	8.03	6.54	8.57	6.38	8.88	6.50	9.64	6.66	10.17	6.82
	105	7.31	5.97	7.84	6.37	8.38	6.23	8.77	6.40	9.45	6.51	9.99	6.68
	110	7.12	5.77	7.66	6.17	8.19	6.03	8.58	6.20	9.26	6.33	9.80	6.50
115	6.94	5.59	7.47	5.99	8.01	5.87	8.39	6.05	9.08	6.18	9.61	6.35	
118	6.82	5.55	7.36	5.96	7.89	5.84	8.28	6.02	8.96	6.15	9.50	6.33	
122	6.79	5.54	7.32	5.94	7.86	5.83	8.24	6.01	8.93	6.15	9.46	6.32	

TC = Total Capacity (kBtu/h).

SHC: Sensible Heat Capacity (kBtu/h).

Nominal capacity as rated 0 ft. above sea level and a 0 ft. level difference between outdoor and indoor units. Corresponding refrigerant piping length is accordance with standard length of each outdoor unit.

Nominal cooling capacity rating obtained with air entering the indoor unit at 80°F dry bulb (DB) and 67°F wet bulb (WB), and outdoor ambient conditions of 95°F dry bulb (DB) and 75°F wet bulb (WB).

The shaded table columns and rows indicate reference data. When operating at this temperature, these values can be different if the system is not running consistently.

Four-Way Ceiling-Cassette

FOUR-WAY CEILING CASSETTE INDOOR UNITS **MULTI F** **MULTI F MAX**

Cooling Capacity Table

Table 67: Multi F Four-Way Ceiling-Cassette Indoor Units Cooling Capacity Table.

Model No. / Nominal Capacity of Indoor Unit (Btu/h)	Outdoor Air Temp. (°F DB)	Indoor Air Temp. °F DB / °F WB											
		68 / 57		73 / 61		77 / 64		80 / 67		86 / 72		90 / 75	
		TC	SHC	TC	SHC	TC	SHC	TC	SHC	TC	SHC	TC	SHC
LCN127HV4 12,000	14	11.76	8.51	12.49	8.99	13.22	8.70	13.75	8.88	14.69	8.96	15.42	9.13
	20	11.75	8.57	12.48	9.06	13.21	8.77	13.74	8.95	14.67	9.03	15.40	9.20
	25	11.75	8.64	12.48	9.13	13.20	8.84	13.73	9.02	14.66	9.10	15.39	9.27
	30	11.74	8.71	12.47	9.20	13.19	8.90	13.72	9.09	14.65	9.17	15.38	9.34
	35	11.73	8.77	12.46	9.27	13.18	8.97	13.71	9.16	14.64	9.24	15.37	9.41
	40	11.72	8.84	12.45	9.34	13.17	9.04	13.70	9.23	14.63	9.31	15.36	9.48
	45	11.71	8.90	12.44	9.41	13.16	9.11	13.69	9.30	14.62	9.38	15.35	9.55
	50	11.70	8.97	12.43	9.47	13.15	9.17	13.68	9.37	14.61	9.45	15.33	9.62
	55	11.69	9.03	12.42	9.54	13.14	9.24	13.67	9.44	14.60	9.52	15.32	9.70
	60	11.68	9.10	12.41	9.61	13.13	9.31	13.66	9.50	14.59	9.58	15.31	9.77
	65	11.67	9.17	12.40	9.68	13.12	9.38	13.65	9.57	14.57	9.65	15.30	9.84
	70	11.66	9.23	12.39	9.75	13.11	9.44	13.64	9.64	14.56	9.72	15.29	9.91
	75	11.38	9.08	12.11	9.60	12.83	9.31	13.35	9.51	14.27	9.60	15.00	9.79
	80	11.10	8.92	11.82	9.45	12.55	9.17	13.07	9.38	13.99	9.48	14.71	9.68
	85	10.83	8.76	11.54	9.29	12.26	9.03	12.78	9.24	13.70	9.36	14.42	9.56
	90	10.55	8.60	11.26	9.13	11.98	8.88	12.50	9.10	13.42	9.22	14.13	9.43
	95	10.25	8.51	10.96	9.05	11.67	8.82	12.00	8.90	13.10	9.18	13.81	9.39
	100	10.00	8.28	10.71	8.82	11.42	8.61	11.84	8.76	12.85	8.98	13.56	9.20
	105	9.75	8.05	10.46	8.59	11.17	8.40	11.69	8.62	12.60	8.78	13.31	9.01
	110	9.50	7.77	10.21	8.31	10.92	8.14	11.44	8.37	12.35	8.53	13.07	8.76
115	9.25	7.54	9.96	8.08	10.67	7.92	11.19	8.15	12.10	8.33	12.82	8.56	
118	9.10	7.49	9.81	8.03	10.52	7.88	11.04	8.12	11.95	8.30	12.67	8.54	
122	9.05	7.47	9.76	8.01	10.48	7.87	10.99	8.11	11.90	8.29	12.62	8.53	
LMCN185HV 18,000	14	17.65	12.33	18.74	13.02	19.84	12.61	20.63	12.88	22.03	12.98	23.12	13.23
	20	17.63	12.43	18.73	13.13	19.82	12.71	20.61	12.98	22.01	13.09	23.11	13.33
	25	17.62	12.52	18.71	13.23	19.81	12.81	20.60	13.08	22.00	13.19	23.09	13.44
	30	17.60	12.62	18.70	13.33	19.79	12.91	20.58	13.18	21.98	13.29	23.07	13.54
	35	17.59	12.71	18.68	13.43	19.78	13.00	20.57	13.28	21.96	13.39	23.05	13.64
	40	17.58	12.81	18.67	13.53	19.76	13.10	20.55	13.38	21.94	13.49	23.04	13.75
	45	17.56	12.90	18.66	13.63	19.75	13.20	20.53	13.48	21.93	13.59	23.02	13.85
	50	17.55	13.00	18.64	13.73	19.73	13.30	20.52	13.58	21.91	13.69	23.00	13.95
	55	17.54	13.10	18.63	13.83	19.72	13.39	20.50	13.68	21.89	13.79	22.98	14.05
	60	17.52	13.19	18.61	13.93	19.70	13.49	20.49	13.78	21.88	13.89	22.97	14.16
	65	17.51	13.29	18.60	14.03	19.69	13.59	20.47	13.87	21.86	13.99	22.95	14.26
	70	17.50	13.38	18.58	14.13	19.67	13.69	20.46	13.97	21.84	14.09	22.93	14.36
	75	17.08	13.16	18.16	13.92	19.24	13.49	20.03	13.79	21.41	13.92	22.50	14.20
	80	16.66	12.93	17.74	13.70	18.82	13.30	19.60	13.60	20.98	13.75	22.06	14.03
	85	16.24	12.70	17.32	13.47	18.40	13.09	19.17	13.40	20.55	13.56	21.63	13.85
	90	15.82	12.46	16.90	13.23	17.97	12.88	18.75	13.19	20.12	13.37	21.20	13.67
	95	15.37	12.33	16.44	13.12	17.51	12.78	18.00	12.90	19.65	13.30	20.72	13.61
	100	14.99	12.00	16.06	12.78	17.13	12.47	17.77	12.70	19.28	13.01	20.35	13.33
	105	14.62	11.67	15.69	12.45	16.76	12.17	17.53	12.50	18.90	12.73	19.97	13.05
	110	14.24	11.27	15.32	12.05	16.39	11.79	17.16	12.13	18.53	12.36	19.60	12.70
115	13.87	10.93	14.94	11.71	16.01	11.48	16.79	11.82	18.15	12.07	19.22	12.41	
118	13.65	10.85	14.72	11.64	15.79	11.42	16.56	11.77	17.93	12.03	19.00	12.37	
122	13.57	10.83	14.64	11.62	15.71	11.40	16.49	11.75	17.85	12.01	18.92	12.36	

TC = Total Capacity (kBtu/h).

SHC: Sensible Heat Capacity (kBtu/h).

Nominal capacity as rated 0 ft. above sea level and a 0 ft. level difference between outdoor and indoor units. Corresponding refrigerant piping length is accordance with standard length of each outdoor unit.

Nominal cooling capacity rating obtained with air entering the indoor unit at 80°F dry bulb (DB) and 67°F wet bulb (WB), and outdoor ambient conditions of 95°F dry bulb (DB) and 75°F wet bulb (WB).

The shaded table columns and rows indicate reference data. When operating at this temperature, these values can be different if the system is not running consistently.

MULTI F FOUR-WAY CEILING-CASSETTE INDOOR UNITS

MULTI F MAX Heating Capacity Table

Table 68: Multi F Four-Way Ceiling-Cassette Indoor Units Heating Capacity Table.

Model No. / Nominal Capacity of Indoor Unit (Btu/h)	Outdoor Air Temp.		Indoor Air Temp. °F DB					
	°F DB	°F WB	61	64	68	70	72	75
			TC	TC	TC	TC	TC	TC
LMCN077HV 7,000	0	-0.4	4.17	4.11	4.07	4.05	3.99	3.82
	5	4.5	4.70	4.64	4.60	4.58	4.52	4.34
	10	9	5.22	5.17	5.13	5.11	5.05	4.87
	17	15	5.93	5.87	5.83	5.81	5.75	5.56
	20	19	6.19	6.13	6.09	6.08	6.02	5.81
	25	23	6.63	6.57	6.53	6.52	6.46	6.22
	30	28	7.01	6.96	6.92	6.90	6.84	6.63
	35	32	7.40	7.34	7.30	7.28	7.22	7.04
	40	36	7.74	7.68	7.64	7.62	7.56	7.39
	45	41	8.08	8.02	7.98	7.96	7.90	7.73
	47	43	8.22	8.16	8.12	8.10	8.04	7.87
	50	46	8.35	8.29	8.25	8.23	8.17	7.98
	55	51	8.57	8.51	8.47	8.45	8.39	8.16
	60	56	8.57	8.51	8.47	8.45	8.39	8.20
	63	59	8.57	8.51	8.47	8.45	8.39	8.22
LCN097HV4 9,000	0	-0.4	5.35	5.28	5.23	5.20	5.12	4.90
	5	4.5	6.03	5.95	5.90	5.88	5.80	5.58
	10	9	6.71	6.63	6.58	6.56	6.48	6.26
	17	15	7.61	7.54	7.49	7.46	7.39	7.14
	20	19	7.95	7.88	7.83	7.80	7.72	7.46
	25	23	8.52	8.44	8.39	8.37	8.29	7.99
	30	28	9.01	8.93	8.88	8.86	8.78	8.52
	35	32	9.50	9.42	9.37	9.34	9.27	9.04
	40	36	9.94	9.86	9.81	9.78	9.71	9.48
	45	41	10.37	10.30	10.25	10.22	10.15	9.92
	47	43	10.55	10.48	10.43	10.40	10.32	10.10
	50	46	10.72	10.64	10.59	10.57	10.49	10.24
	55	51	11.00	10.93	10.88	10.85	10.78	10.48
	60	56	11.00	10.93	10.88	10.85	10.78	10.52
	63	59	11.00	10.93	10.88	10.85	10.78	10.55
68	64	11.00	10.93	10.88	10.85	10.78	10.60	

TC = Total Capacity (kBtu/h).

Nominal capacity as rated 0 ft. above sea level and a 0 ft. level difference between outdoor and indoor units. Corresponding refrigerant piping length is accordance with standard length of each outdoor unit. Nominal heating capacity rating obtained with air entering the indoor unit at 70°F dry bulb (DB) and 60°F wet bulb (WB), and outdoor ambient conditions of 47°F dry bulb (DB) and 43°F wet bulb (WB).

Four-Way Ceiling-Cassette

FOUR-WAY CEILING-CASSETTE INDOOR UNITS MULTI F

Heating Capacity Table MULTI F MAX

Table 69: Multi F Four-Way Ceiling-Cassette Indoor Units Heating Capacity Table.

Model No. / Nominal Capacity of Indoor Unit (Btu/h)	Outdoor Air Temp.		Indoor Air Temp. °F DB					
	°F DB	°F WB	61	64	68	70	72	75
			TC	TC	TC	TC	TC	TC
LCN127HV4 12,000	0	-0.4	7.10	7.00	6.93	6.90	6.80	6.50
	5	4.5	8.00	7.90	7.83	7.80	7.70	7.40
	10	9	8.90	8.80	8.73	8.70	8.60	8.30
	17	15	10.10	10.00	9.93	9.90	9.80	9.48
	20	19	10.55	10.45	10.38	10.35	10.25	9.90
	25	23	11.30	11.20	11.13	11.10	11.00	10.60
	30	28	11.95	11.85	11.78	11.75	11.65	11.30
	35	32	12.60	12.50	12.43	12.40	12.30	12.00
	40	36	13.18	13.08	13.02	12.98	12.88	12.58
	45	41	13.77	13.67	13.60	13.57	13.47	13.17
	47	43	14.00	13.90	13.83	13.80	13.70	13.40
	50	46	14.23	14.13	14.06	14.03	13.93	13.59
	55	51	14.60	14.50	14.43	14.40	14.30	13.90
	60	56	14.60	14.50	14.43	14.40	14.30	13.96
	63	59	14.60	14.50	14.43	14.40	14.30	14.00
	68	64	14.60	14.50	14.43	14.40	14.30	14.06
LMCN185HV 18,000	0	-0.4	10.70	10.55	10.45	10.40	10.25	9.80
	5	4.5	12.06	11.91	11.81	11.76	11.61	11.15
	10	9	13.41	13.26	13.16	13.11	12.96	12.51
	17	15	15.22	15.07	14.97	14.92	14.77	14.29
	20	19	15.90	15.75	15.65	15.60	15.45	14.92
	25	23	17.03	16.88	16.78	16.73	16.58	15.98
	30	28	18.01	17.86	17.76	17.71	17.56	17.03
	35	32	18.99	18.84	18.74	18.69	18.54	18.09
	40	36	19.87	19.72	19.62	19.57	19.42	18.97
	45	41	20.75	20.60	20.50	20.45	20.30	19.85
	47	43	21.10	20.95	20.85	20.80	20.65	20.20
	50	46	21.44	21.29	21.19	21.14	20.99	20.48
	55	51	22.01	21.86	21.75	21.70	21.55	20.95
	60	56	22.01	21.86	21.75	21.70	21.55	21.04
	63	59	22.01	21.86	21.75	21.70	21.55	21.10
	68	64	22.01	21.86	21.75	21.70	21.55	21.20

TC = Total Capacity (kBtu/h).

Nominal capacity as rated 0 ft. above sea level and a 0 ft. level difference between outdoor and indoor units. Corresponding refrigerant piping length is accordance with standard length of each outdoor unit. Nominal heating capacity rating obtained with air entering the indoor unit at 70°F dry bulb (DB) and 60°F wet bulb (WB), and outdoor ambient conditions of 47°F dry bulb (DB) and 43°F wet bulb (WB).

MULTI F FOUR-WAY CEILING-CASSETTE INDOOR UNITS

MULTI F MAX Acoustic Data

Figure 160: Sound Pressure Level Measurement Location.

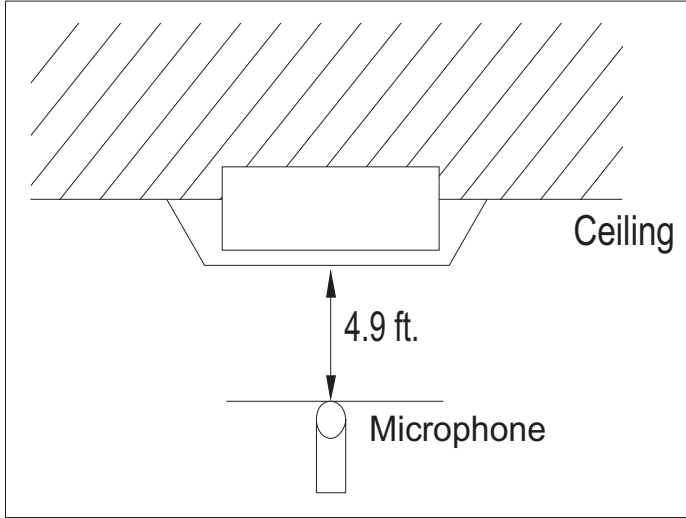

- Measurement taken 4.9' away from the unit.
- Measurements taken with no attenuation and units operating at full load normal operating condition.
- Sound level will vary depending on a range of factors such as construction (acoustic absorption coefficient) of particular area in which the equipment is installed.
- Sound power levels are measured in dB(A)±3.
- Tested in anechoic chamber per ISO Standard 3745.

Table 70: Sound Pressure Levels (dB[A]).

Model No.	Sound Pressure Levels (dB[A]) (Cooling and Heating)		
	High Fan Speed	Medium Fan Speed	Low Fan Speed
LMCN077HV	31	27	24
LCN097HV4	36	33	30
LCN127HV4	38	35	32
LMCN185HV	38	37	34

Figure 161: LMCN077HV and LCN097HV4 Sound Pressure Level Diagrams.

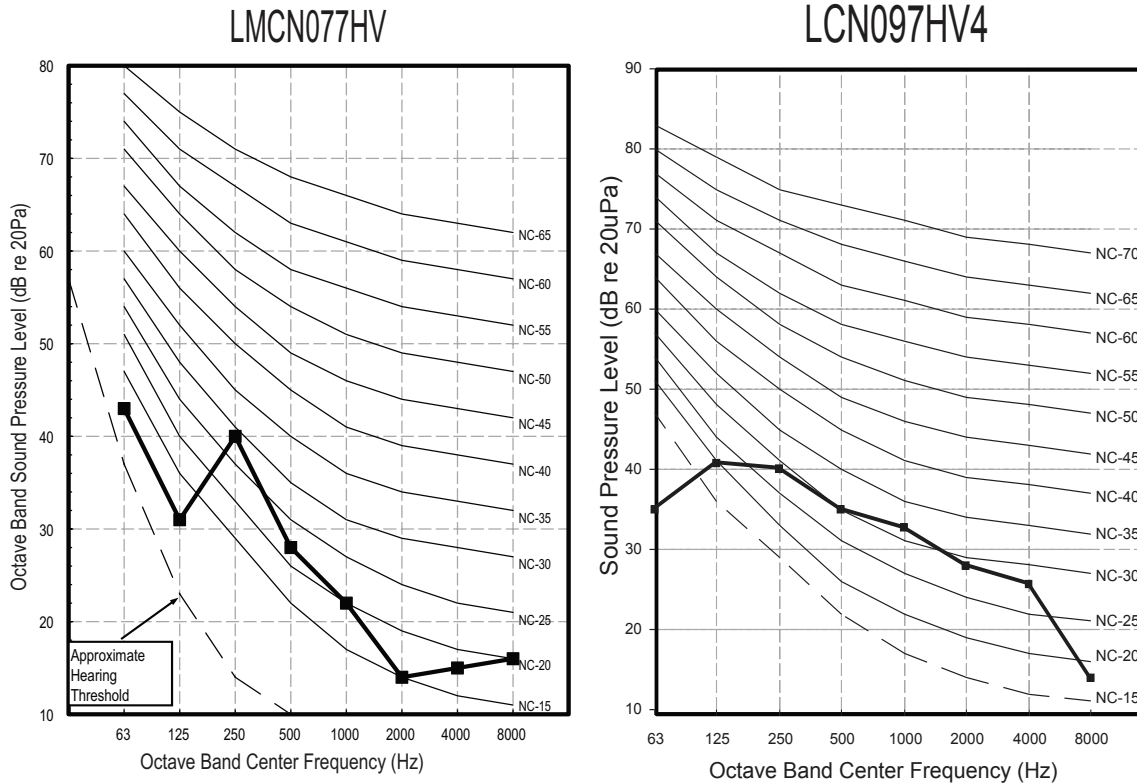

Four-Way Ceiling-Cassette

FOUR-WAY CEILING CASSETTE INDOOR UNITS **MULTI F** **MULTI F MAX**

Acoustic Data

Figure 162: LCN127HV4 and LMCN185HV Sound Pressure Level Diagrams.

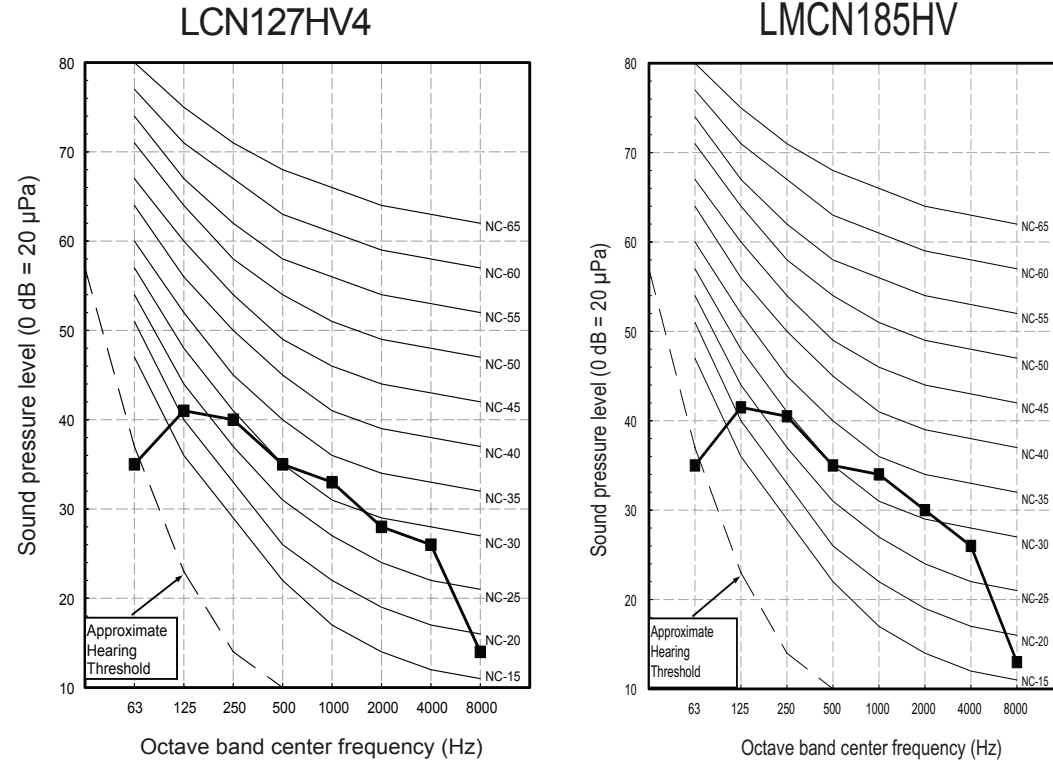

Multi F and Multi F MAX Indoor Unit Engineering Manual

MULTI F FOUR-WAY CEILING-CASSETTE INDOOR UNITS

MULTI F MAX Air Velocity and Temperature Distribution

Figure 163:LMCN077HV Air Velocity and Temperature Distribution Charts.

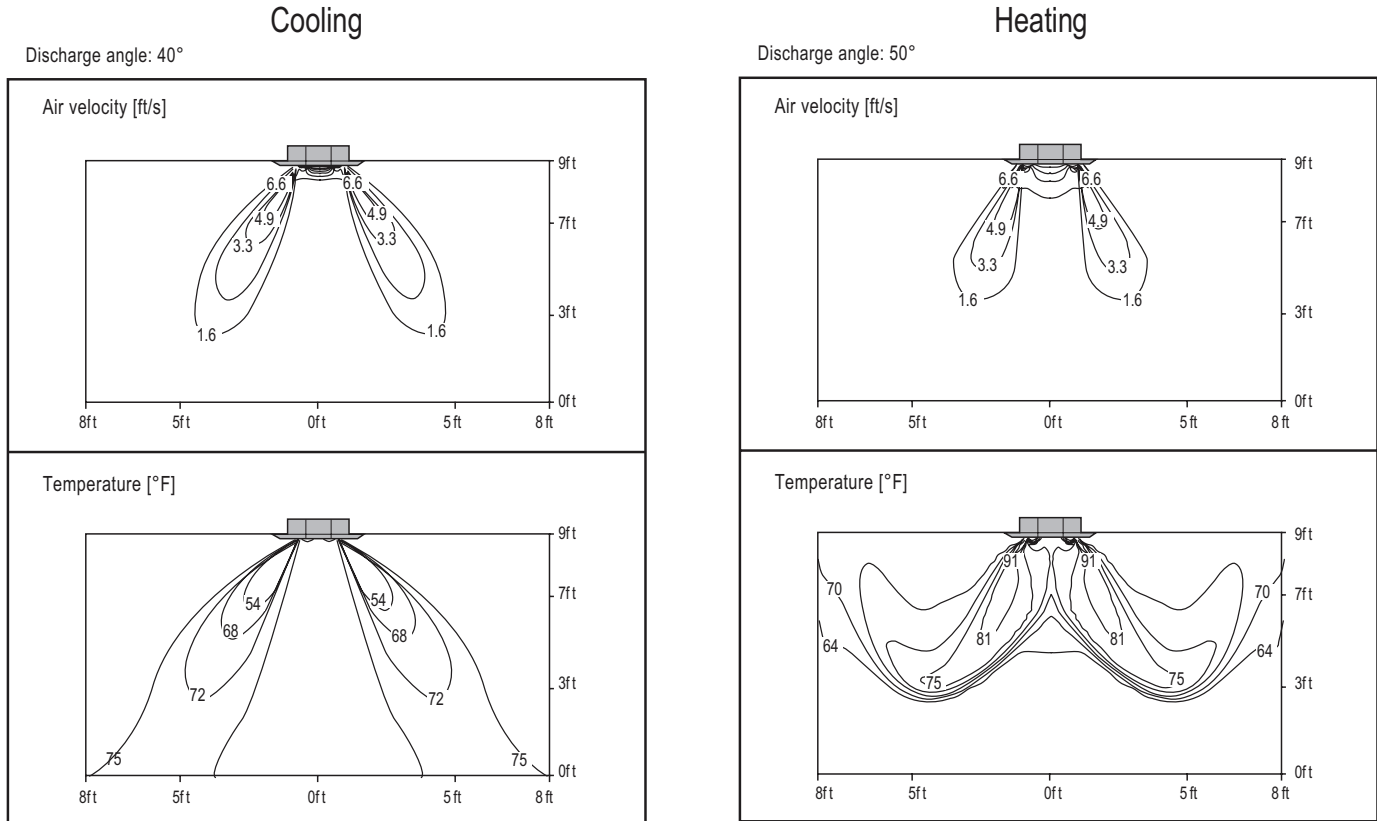
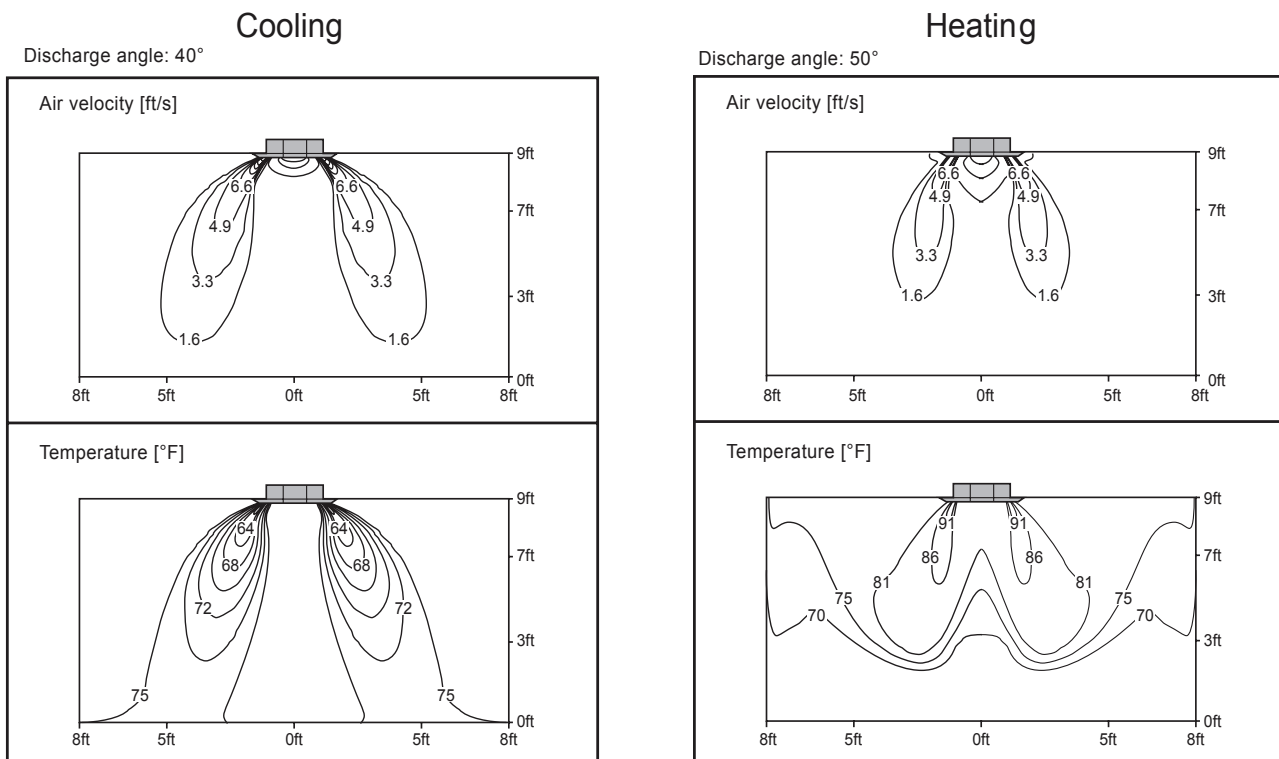

Figure 164:LCN097HV4 Air Velocity and Temperature Distribution Charts.



Four-Way Ceiling-Cassette

FOUR-WAY CEILING CASSETTE INDOOR UNITS MULTI F MULTI F MAX

Air Velocity and Temperature Distribution

Figure 165: LCN127HV4 Air Velocity and Temperature Distribution Charts.

Cooling

Heating

Discharge angle: 40°

Discharge angle: 50°

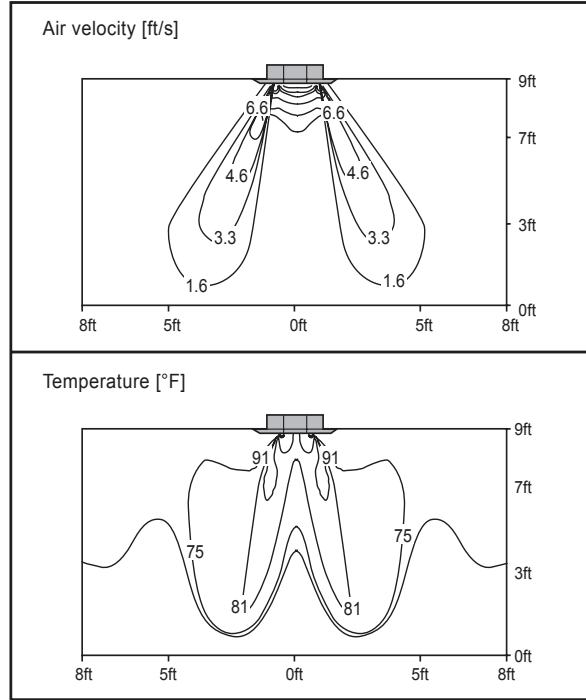
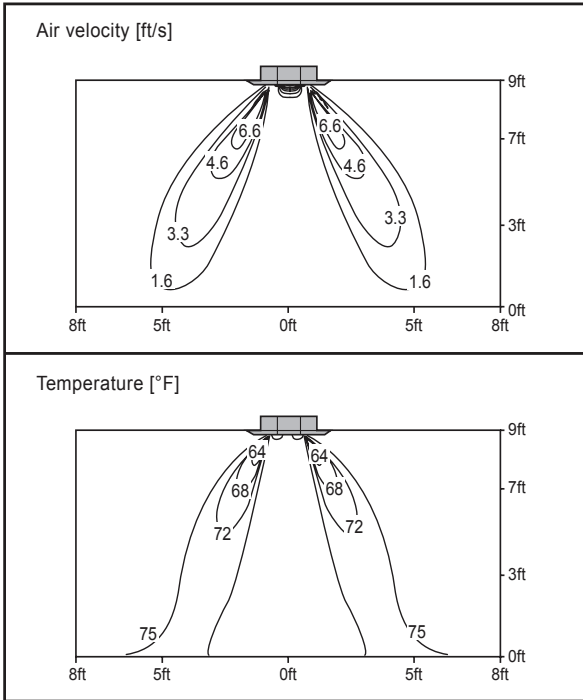

Figure 166: LMCN185HV Air Velocity and Temperature Distribution Charts.

Cooling

Heating

Discharge angle : 40°

Discharge angle : 50°

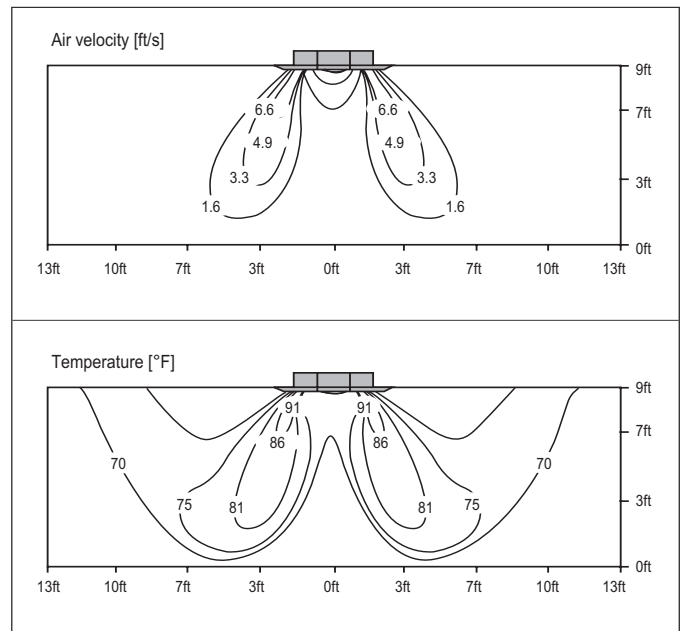
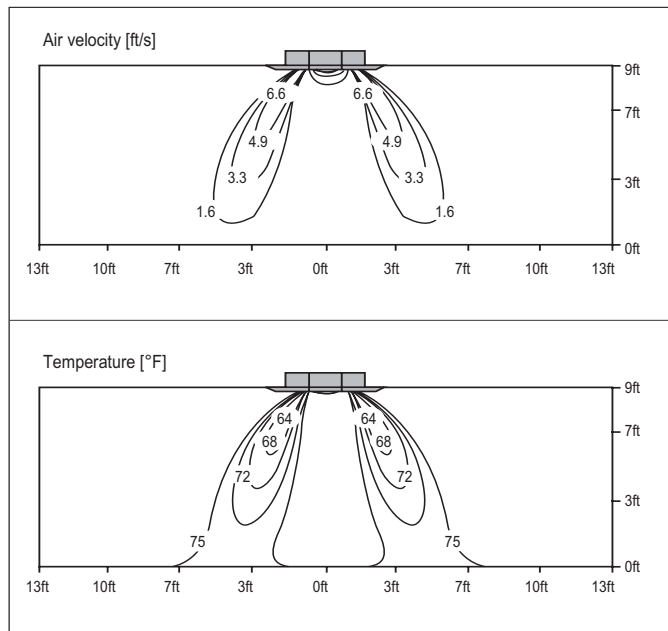

MULTI F FOUR-WAY CEILING-CASSETTE INDOOR UNITS

MULTI F MAX

Refrigerant Flow Diagram

Figure 167: Multi F Four-Way Ceiling-Cassette Indoor Unit Refrigerant Flow Diagram.

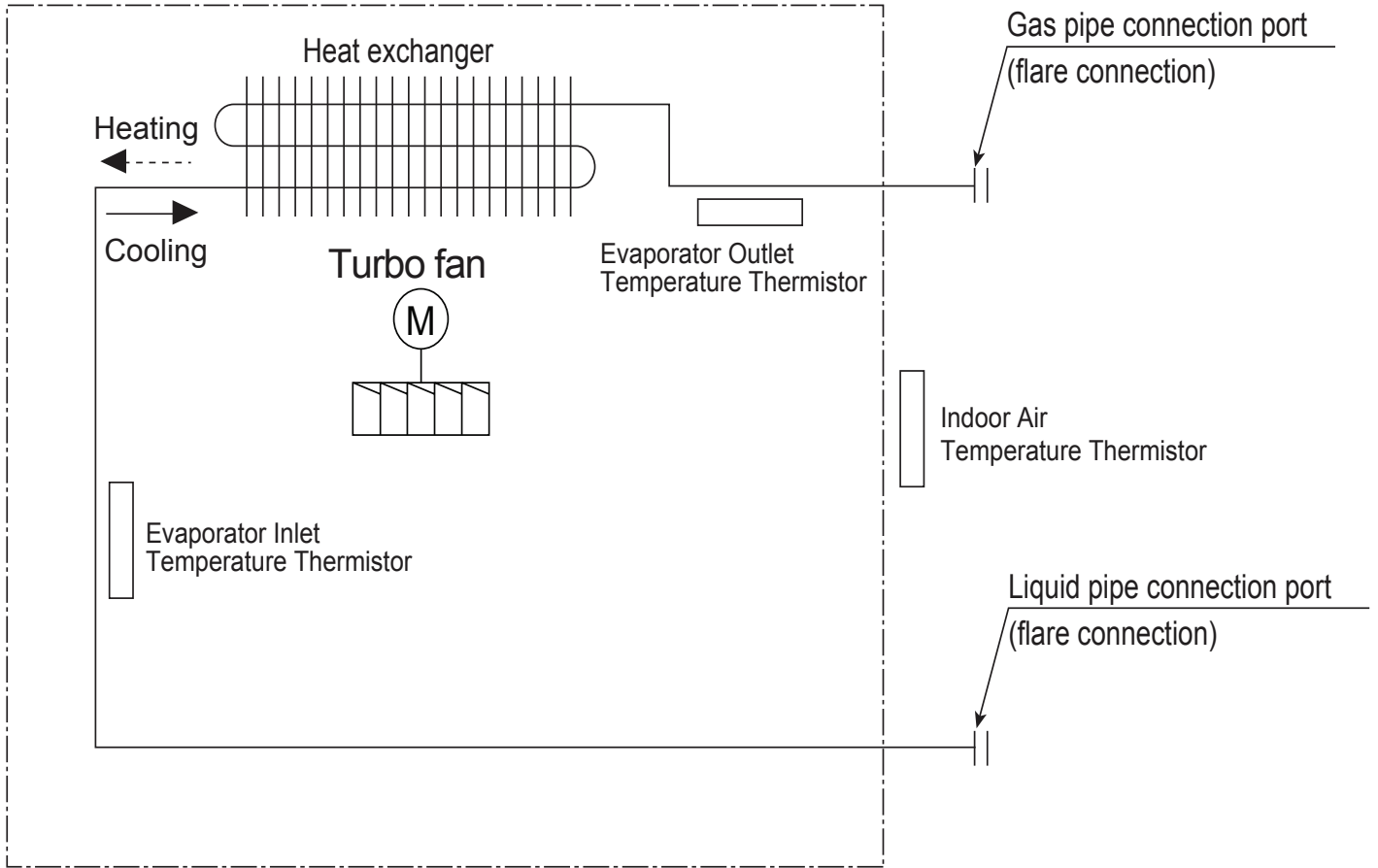

Four-Way Ceiling-Cassette

Table 71: Multi F Four-Way Ceiling-Cassette Indoor Unit Refrigerant Pipe Connection Port Diameters.

Model No.	Vapor (inch)	Liquid (inch)
LMCN077HV	Ø3/8	Ø1/4
LCN097HV4		
LCN127HV4		
LMCN185HV	Ø1/2	

Table 72: Multi F Four-Way Ceiling-Cassette Indoor Unit Thermistor Details.

Description (Based on Cooling Mode)	PCB Connector
Indoor Air Temperature Thermistor	CN-ROOM
Evaporator Inlet Temperature Thermistor	CN-PIPE/IN
Evaporator Outlet Temperature Thermistor	CN-PIPE/OUT

FOUR-WAY CEILING CASSETTE INDOOR UNITS **MULTI F** **MULTI F MAX**

Wiring Diagram

Figure 168: Multi F Four-Way Ceiling-Cassette Indoor Unit Wiring Diagram.

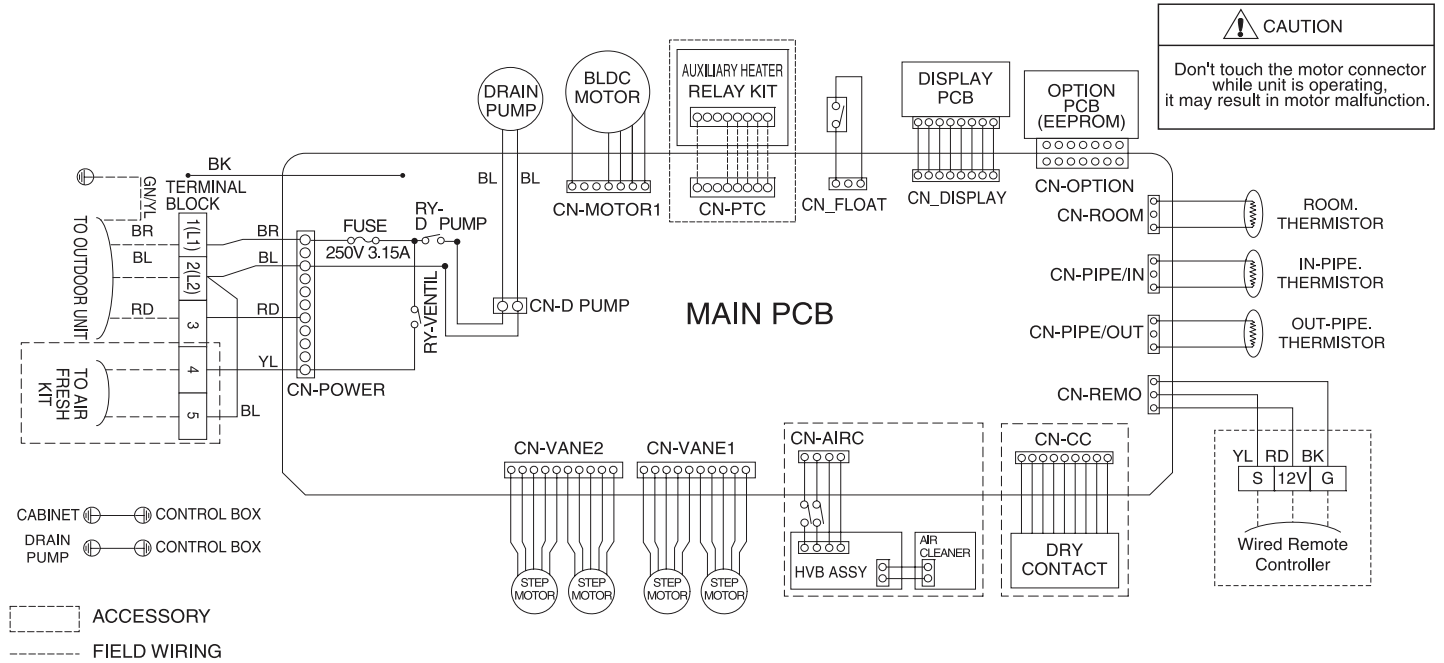



Multi F and Multi F MAX Indoor Unit Engineering Manual

MULTI F FOUR-WAY CEILING-CASSETTE INDOOR UNITS

MULTI F MAX Factory Supplied Parts and Materials

Factory Supplied Parts

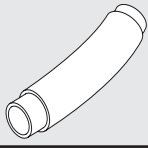
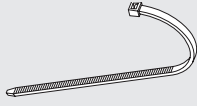
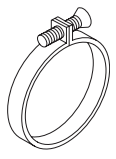
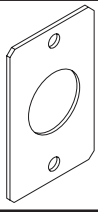
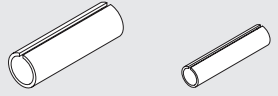
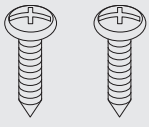
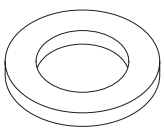
Table 73: Parts Table.

Part	Quantity	Image	Part	Quantity	Image
Drain Hose	One (1)		Zip Ties	Four (4)	
Metal Clamp	Two (2)		Conduit Bracket	One (1)	
Insulation for Fittings	One (1) Set	 For Vapor Piping For Liquid Piping	M4 Screws	Two (2)	
Washer for Hanging Bracket	Eight (8)		Wireless Handheld Controller with Holder (AKB73757604) ¹	One (1)	

¹Wireless Handheld Controller for the four-way ceiling cassette indoor units is also referenced by Model No. PQWRHQ0FDB.

Table 74: Required Accessory Table.

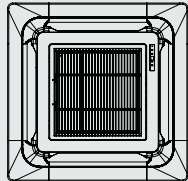
Part	Quantity	Image
Grille Kit (PT-QCHW0 or PT-UQC)	One (1)	

Factory Supplied Materials

- Installation Guide (template)
- Owner's Manual
- Installation Manual

⚠ WARNING

Installation work must be performed by trained personnel and in accordance with national wiring standards and all local or other applicable codes. Improper installation can result in fire, electric shock, physical injury, or death.

Note:

Read all instructions before installing this product. Become familiar with the unit's components and connections, and the order of installation. Incorrect installation can degrade or prevent proper operation.



FOUR-WAY CEILING CASSETTE INDOOR UNITS MULTI F MULTI F MAX

Installation and Best Layout Practices

Selecting the Best Location

Do's

- Place the unit where air circulation will not be blocked.
- Place the unit where drainage can be obtained easily.
- Place the unit where noise prevention is taken into consideration.
- Ensure there is sufficient strength to bear the load of the indoor unit.
- Ensure there is sufficient maintenance space.
- Locate the indoor unit in a location that is level, and where it can be easily connected to the outdoor unit / branch distribution unit.

Don'ts

- Do not install the unit near a heat or steam source, or where considerable amounts of oil, iron powder, or flour are used.
- Do not install the unit where sulfuric acid and flammable or corrosive gases are generated, vented into, or stored.
- Do not install the unit near high-frequency generators.
- Do not install the unit near a doorway.

The unit may be damaged, may malfunction, and/or will not operate as designed if installed in any of the conditions listed.

Note:

If the unit is installed near a body of water, certain components are at risk of being corroded. Appropriate anti-corrosion methods should be taken for the unit and all components.

Installing in a High or Dropped Ceiling

High or dropped ceilings, often found in commercial buildings and offices, may cause a wide temperature differentiation. To countermeasure:

- Change the indoor unit mode selection to allow for higher ceilings (see table).
- Install an air circulator.
- Set the air discharge outlet so that heated air flows in a downward direction.
- Use a dual door system to protect the building gate or exit.

Installing in an Area Exposed to Unconditioned Air

In some installation applications, areas (floors, walls) in some rooms may be exposed to unconditioned air (room may be above or next to an unheated garage or storeroom). To countermeasure:

- Verify that carpet is or will be installed (carpet may increase the temperature by three (3) degrees).
- Add insulation between the floor joists.
- Install radiant heat or another type of heating system to the floor.

Installing in an Area with High Humidity Levels

If the environment is prone to humidity levels of 80% or more (near the ocean, lakes, etc.) or where steam could collect in the plenum:

- Install additional insulation to the indoor unit (glass wool insulation >13/32 inches thick).
- Install additional insulation to the refrigerant piping (insulation >13/16 inches thick).
- Seal all gaps between the indoor unit and the ceiling tiles (make the area air tight) so that humidity does not transfer from the plenum to the conditioned space. Also, add a ceiling grille for ventilation.

Figure 169: Indoor Unit Clearance Requirements.

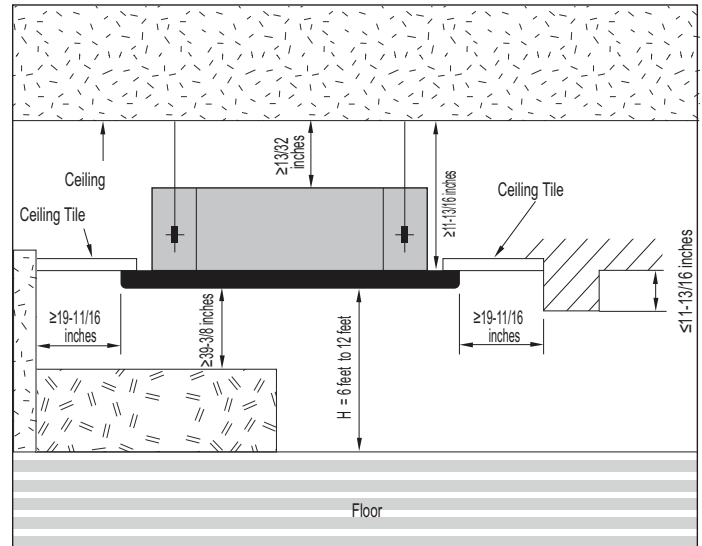
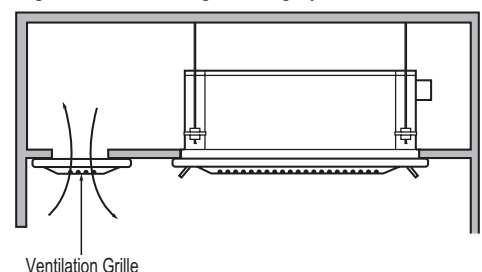

Table 75: Indoor Unit High Ceiling Mode Selection Options.

Ceiling Height	Mode Selection
≤7-1/2 feet	Low Ceiling
7-1/2 feet to 8-7/8 feet	Standard
8-7/8 feet to 10-3/16 feet	High Ceiling
10-3/16 feet to 11-13/16 feet	Very High Ceiling

Figure 170: Installing in a Highly Humid Location.



FOUR-WAY CEILING CASSETTE INDOOR UNITS **MULTI F** **MULTI F MAX**

Installation and Best Layout Practices

For New Ceilings

1. Use a sunken insert, a sunken anchor, or any other field-supplied part to reinforce the ceiling so that it can bear the weight of the indoor unit. Use a temporary washer plate to more easily set up the unit suspension location.
2. Ceiling height is shown on the side of the installation guide (template). Adjust the height of the unit accordingly. Adjust the clearance before hanging the indoor unit.
3. Refer to the installation guide (template) for the dimensions to the ceiling opening. Match the center of the indoor unit (labeled) to the center indicated on the installation guide.
4. Align the installation guide (template) with the label attached to the unit (affixing the template to the unit if desired) to properly place the unit.
5. Remove the temporary washer plate and position the indoor unit hanger brackets on the bolts. Secure with nuts and washers on the top and bottom of the hanger brackets.
6. Ceiling-cassette indoor units are equipped with a built-in drain pump and float switch, therefore, the unit must be installed horizontally or condensate will drip out and cause product malfunction. Measure the unit at each corner to verify that it is level.
7. Remove the installation guide (template).

Figure 175: Hanging the Indoor Unit.

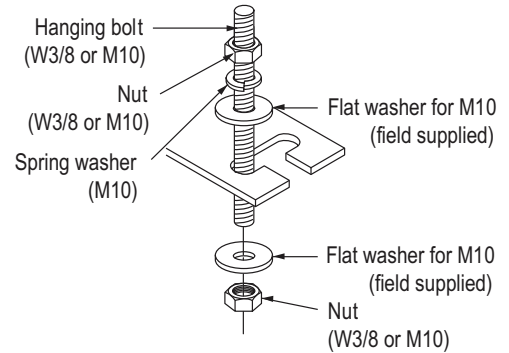

For Existing Ceilings

1. Use anchors when installing the indoor unit in an existing ceiling.
2. Ceiling height is shown on the side of the installation guide (template). Adjust the height of the unit accordingly. Adjust the clearance before hanging the indoor unit.
3. Remove the temporary washer plate and position the indoor unit hanger brackets on the bolts. Secure with nuts and washers on the top and bottom of the hanger brackets.
4. Ceiling-cassette indoor units are equipped with a built-in drain pump and float switch, therefore, the unit must be installed horizontally or condensate will drip out and cause product malfunction. Measure the unit at each corner to verify that it is level.
5. Remove the installation guide (template).

Installing the Drain System

- Drain piping must have downward gradient of at least 1/50 to 1/100; to prevent reverse flow, slope should not be straight up and down.
- Do not damage the drain port on the indoor unit when connecting the field-supplied drain piping.
- Drain piping specifications:
 - Indoor Unit Drain Connection: 1-1/4 inch outside diameter.
 - Field-Supplied Drain Piping: Polyvinyl chloride piping with 1-inch inside diameter and pipe fittings.

Figure 176: Indoor Unit Drain Piping.

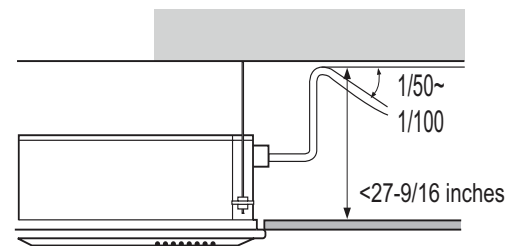

Checking the Drain Pump

The unit uses a drain pump to remove condensate. The pump must be tested before the system operates.

- Connect flexible drain hose to the field-installed drain piping; leave it as is until the test is complete.
- Pour water into the flexible drain hose and check for leaks.
- After power wiring installation is complete, operate the drain pump to see if it sounds and functions properly.
- After the test is complete, connect the flexible drain hose to the indoor unit drain port.

Figure 177: Checking the Drain Pump.

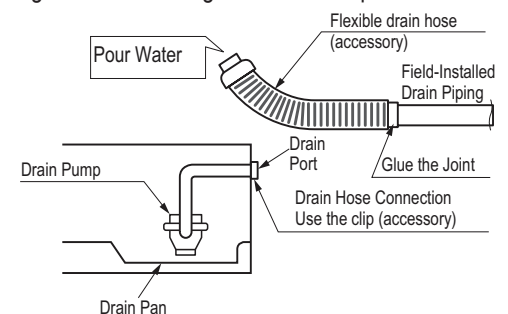

Insulating the Refrigerant and Drain Piping

⚠ WARNING

Ensure all piping is insulated. Exposed piping can cause burns if touched.

Refrigerant Piping Insulation

Field-installed vapor and liquid refrigerant piping lines must be properly and completely covered in insulation (up to the indoor unit piping connections). Any exposed piping may generate condensate or will cause burns if touched. Insulation for this field-installed refrigerant piping must have a minimum heat resistance of 248°F.

Drain Piping Insulation

Drain piping must have insulation a minimum of 7/32 inches thick.

Figure 178: Insulating the Piping.

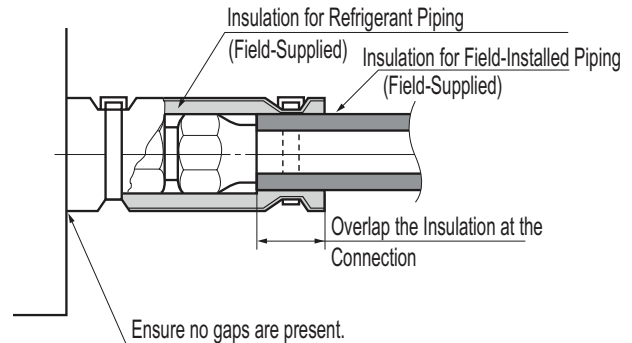

Installing the Insulation

1. Overlap the insulation at the connection of the field-installed piping and the indoor unit piping. Tape together so that no gaps exist.
2. Secure insulation to the rear piping housing section with vinyl tape.
3. Bundle the piping and drain hose with tape where they meet at the back of the indoor unit frame. Position the drain hose at the bottom of the bundle (positioning the drain hose at the top of the bundle may cause the drain pan to overflow inside the indoor unit).

Power Wiring / Communications Cable Guidelines

- Follow manufacturer's circuit diagrams in the technical manuals.
- Confirm power source specifications.
- Confirm that the electrical capacity is sufficient.
- Starting current must be maintained ± 10 percent of the rated current marked on the outdoor unit name plate.
- Confirm cable thickness specifications.
- It is recommended that a circuit breaker is installed, especially if conditions could become wet or moist.
- Include a disconnect in the power wiring system, add an air gap contact separation of at least 1/8 inch in each active (phase) conductor.

⚠ WARNING

• Loose wiring may cause unit to malfunction, overheat, and catch fire, resulting in severe injury or death.

Note:

- Terminal screws may become loose during transport. Properly tighten the terminal connections during installation.
- A voltage drop may cause the following problems:
- Magnetic switch vibration, fuse breaks, or disturbance to the normal function of an overload protection device.
 - Compressor will not receive the proper starting current.

FOUR-WAY CEILING CASSETTE INDOOR UNITS MULTI F MULTI F MAX

Installation and Best Layout Practices

Connecting the Power Wiring and Communications Cable

1. To access the terminal block, open the control box cover.
2. Insert the power wiring / communications cable from the outdoor unit or branch distribution unit (Multi F MAX systems only) through the sides of the indoor unit and control box. Pass the wiring through the designated access holes to prevent damage. To prevent electromagnetic interference and product malfunction, leave a space between the power wiring and communications cable outside of the indoor unit.
3. Connect each wire to its appropriate terminal on the indoor unit control board. Verify that the color and terminal numbers from the outdoor unit or branch distribution unit (Multi F MAX systems only) wiring match the color and terminal numbers on the indoor unit.
4. Neatly arrange power wiring / communications cable and secure with the appropriate cable restraint. ⚠ When clamping, do not apply force to the wiring connections.
5. Firmly reattach the control box cover. ⚠ Do not catch the wiring in the electric box cover and make sure the cover firmly closes.
6. Fill in any gaps around the wiring access holes with sealant to prevent foreign particles from entering the indoor unit.

Figure 179: Power Wiring and Communications Cable Connection Access.

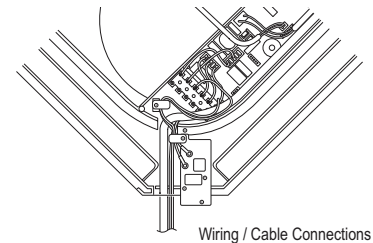
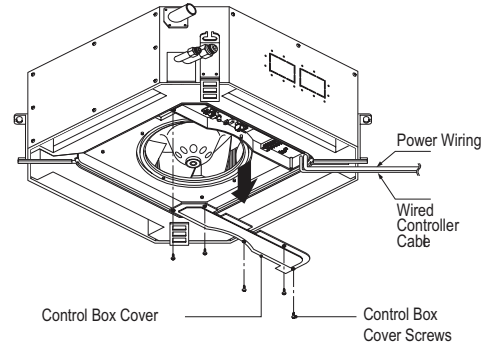
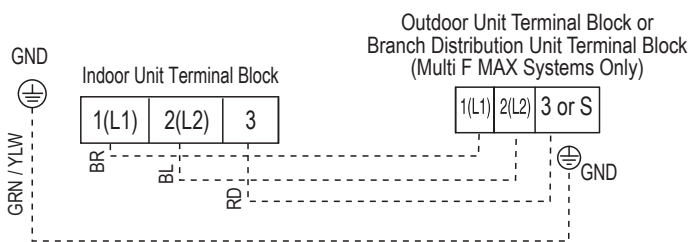

Figure 180: Simplified View of Indoor Unit to Outdoor Unit / Branch Distribution Unit Terminal Connections.



Using a Conduit

1. Remove the rubber stopper on the indoor unit. Pass the power wiring / communications cable through the conduit, the conduit mounting plate, and to / through the control panel of the indoor unit.
2. Tighten the conduit and the conduit mounting plate together.
3. Connect the power wiring / communications cable to the indoor unit terminal block.
4. Screw the conduit mounting plate to the indoor unit.

Note:

If the distance between the outdoor unit and indoor unit is greater than 131 feet, connect the power wiring and communications cable separately (i.e., a conduit cannot be used).

Figure 181: Using a Conduit.

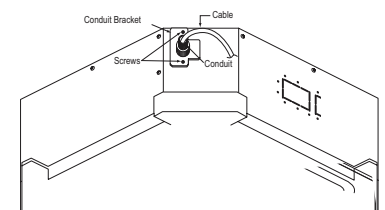
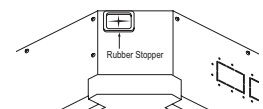

MULTI F FOUR-WAY CEILING-CASSETTE INDOOR UNITS

MULTI F MAX Installation and Best Layout Practices

Controller Options

Four-way ceiling-concealed indoor units include a wireless handheld controller (AKB73757604)¹, but optional LG-supplied wired controllers are available.

Wireless Handheld Controller

Figure 182:AKB73757604 Wireless Handheld Controller.

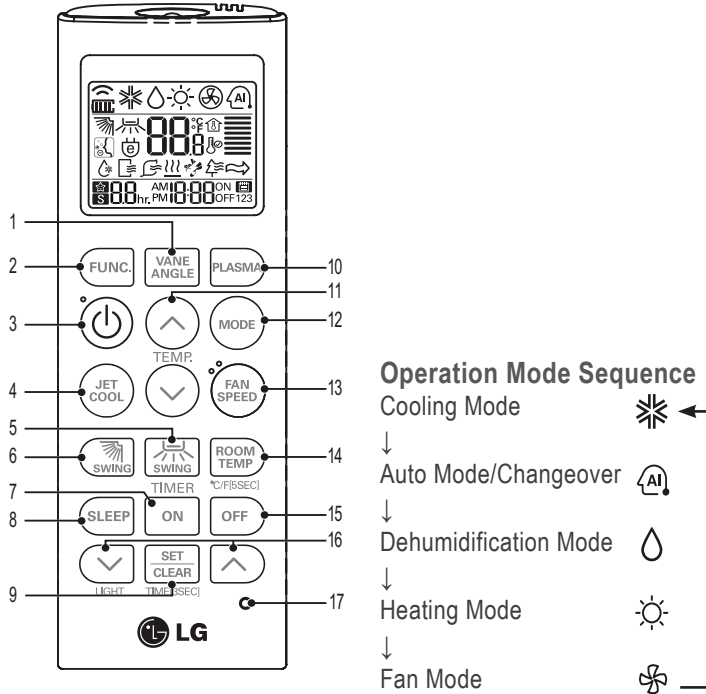

Table 76:AKB73757604¹ Wireless Handheld Controller Functions.²

Button Label	Description
1	Vane Angle Button: Sets the angle to each vane.
2	Function Setting Button: Sets or clears auto clean, smart clean, electric heater, or individual vane angle control functions.
3	On / Off Button: Turns the power on/off.
4	Jet Cool: Sets the unit to super high fan speed when in cooling mode.
5	Left / Right Air Flow Button (optional): Sets the desired left / right (horizontal) air flow direction.
6	Up / Down Air flow Button: Stops or starts louver movement, and sets the desired air flow direction to up or down.
7	On Time Button: Sets the time when the operation begins.
8	Sleep Timer Button: Sets the sleep mode operation.
9	Set / Clear Button: Sets or cancels the timer, also sets the current time.
10	Plasma Button: Starts or stops plasma-purification functions.
11	Room Temperature Setting Button: Raises or lowers temperature setpoint in cooling and heating operation.
12	Operation mode selection button: Selects the operation mode.
13	Indoor Fan Speed Button: Changes the fan speed to one of four choices: low, medium, high, and chaos.
14	Room Temperature Check Button: Displays / checks the room temperature.
15	Off Timer button: Sets the time when the operation ends.
16	Time Setting (Up / Down) / Light Button: Sets the timer and adjusts the brightness of the LED.
17	Reset Button: Resets the remote controller.

Four-Way Ceiling-Cassette

¹Wireless Handheld Controller for the four-way ceiling cassette indoor units is also referenced by Model No. PQWRHQ0FDB.

²Depending on the indoor unit model, some functions may not be supported or displayed.

Wired Controller Connections

Figure 183:Wired Controller Connection on the Indoor Unit Terminal Block.

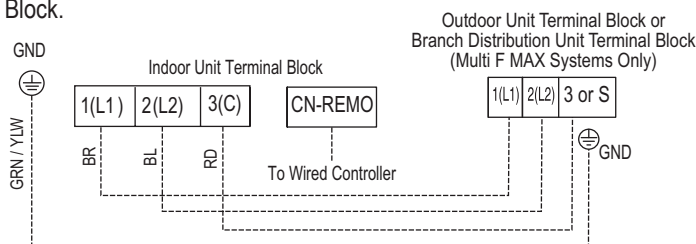

FOUR-WAY CEILING CASSETTE INDOOR UNITS ^{MULTI F} ^{MULTI F MAX}

Installation and Best Layout Practices

Wired Controller Placement

Wired controllers include a sensor to detect room temperature. To maintain comfort levels in the conditioned space, the wired controller must be installed in a location away from direct sunlight, high humidity, and where it could be directly exposed to cold air. Controller must be installed four (4) to five (5) feet above the floor where its LED display can be read easily, in an area with good air circulation, and where it can detect an average room temperature.

- ⊘ Do not install the wired controller near or in:
 - Drafts or dead spots behind doors and in corners
 - Hot or cold air from ducts
 - Radiant heat from the sun or appliances
 - Concealed pipes and chimneys
 - An area where temperatures are uncontrolled, such as an outside wall

Figure 184: Proper Location for the Wired Controller.

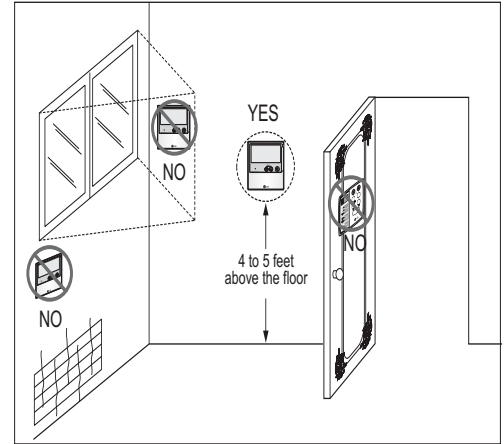

Hanging the Wired Controller

1. The controller wiring / cable can be installed in one of three directions: top, back, or on the right side. If top or right side installation is desired, remove cable guide grooves on the controller, and then position wiring / cable on applicable side.
2. Choose and mark the area of installation, and then screw the wall plate into place (using the provided parts). Install the controller wall plate to fit the electrical box if one is present. Ensure that no gaps exist between the wall plate and the wall itself.
3. Arrange wiring / cables so as not to interfere with the controller circuitry. Position the wired controller on the wall plate. Snap into place by pressing the bottom part of the wired controller onto the wall plate. Make sure that no gaps exist between the wired controller and the wall plate on all sides.
4. To remove wired controller from the wall plate, insert a screwdriver into the two holes at the bottom. Twist screwdriver to release controller. ⊘ Do not damage the controller components when removing.

Figure 185: Removing the Cable Guide Grooves.

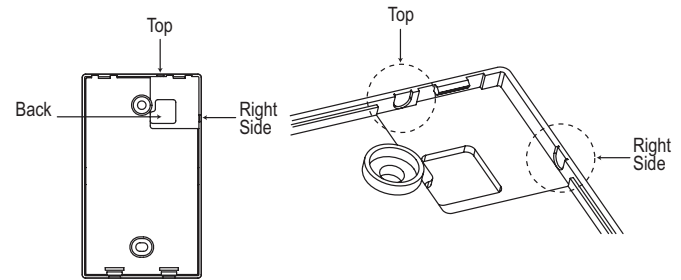

Figure 186: Attaching the Wall Plate.

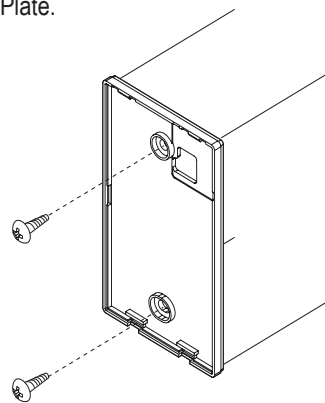
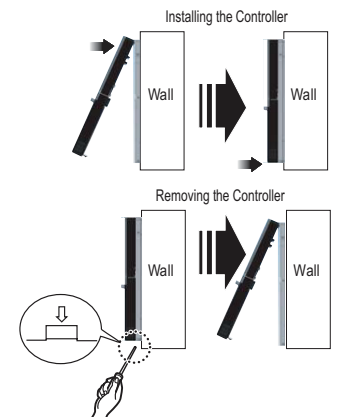

Figure 187: Installing / Removing the Controller.



Assigning the Thermistor for Temperature Detection

Each indoor unit includes a return air thermistor assigned to sense the temperature. If a wired controller is installed, there is a choice of sensing temperature with either the indoor unit return air thermistor or the thermistor in the wired controller. It is also an option to set both thermistors to sense temperature so that indoor unit bases its operation on the first thermistor to reach the designated temperature differential. For applicable indoor units, an optional Remote Temperature Sensor can be used in lieu of the return air thermistor—either alone or in conjunction with a wired controller thermistor as previously described.

MULTI F FOUR-WAY CEILING-CASSETTE INDOOR UNITS

MULTI F MAX Installation and Best Layout Practices

PTVK430 Ventilation Kit

PTVK430 Ventilation Kit includes a flange for field-supplied ventilation pipe connection. Easily connects at the four-way ceiling-cassette three (3) inch fresh air knockout hole.

Figure 188: PTVK430 Ventilation Kit.

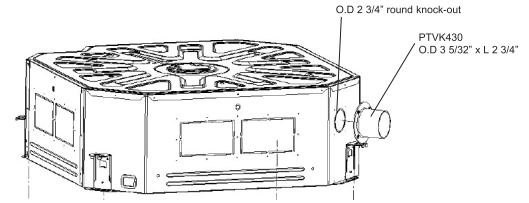

Finalizing Indoor Unit Installation— Installing the Decoration Panel

Note:

Decoration panel must be installed properly; cool air will leak from any gaps found between the indoor unit frame and the decoration panel, which will cause condensation to generate.

1. Remove the packaging, take out air inlet grille from the front panel (1A), and then remove the corner covers of the panel (1B).
2. Attach the panel to the indoor frame by inserting the hooks as shown (2).
3. Attach two screws on diagonal corners of each panel, but do not tighten completely (3). Screws to attach the panel to the indoor unit frame are factory-provided and can be found in the shipping box.
4. Verify the panel is aligned with the ceiling. Adjust the height by using the hanging bolts as shown (4).
5. Attach the corner covers (5).
6. Unscrew the control panel cover (6).
7. Connect the one display connector (CN-DISP) and the two vane control connectors (CN-VANE1, CN-VANE2) of the front panel to the indoor unit PCB (7).
8. Close the control box cover. Attach the link on the front panel as shown (8). The link is supplied in the front panel shipping package.
9. Attach the other side of the link on the filter guide of the air inlet grille, then install the filter and the air inlet grille on the front panel (9).

Figure 189: Installing the Decoration Panel.

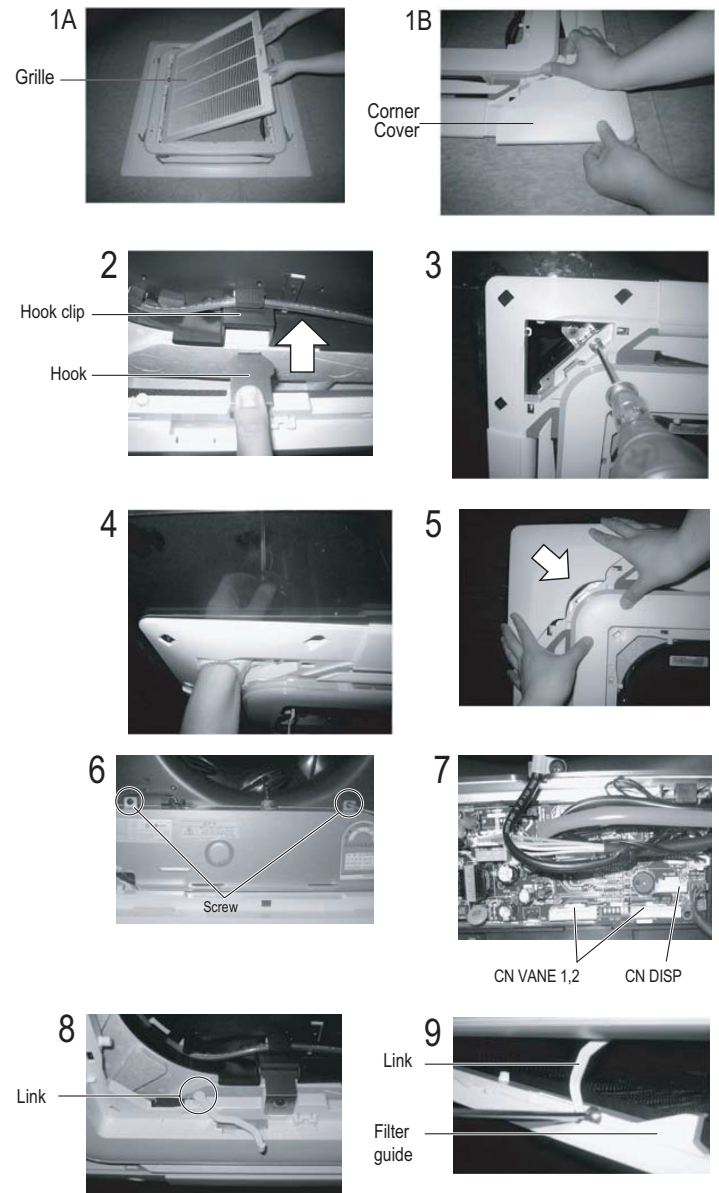
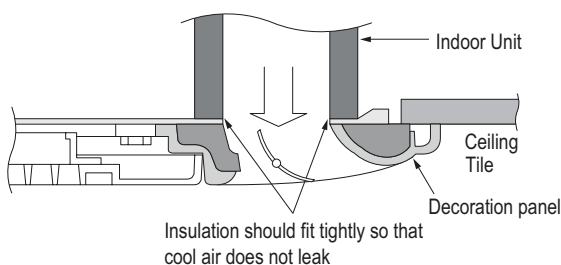

Figure 190: Ensure that no gaps are present between the indoor unit frame and the decoration panel.



TWO-WAY VERTICAL-HORIZONTAL AIR HANDLING INDOOR UNIT DATA

“Mechanical Specifications” on page 137

“General Data / Specifications” on page 138

“Dimensions” on page 139

“Cooling Capacity Table” on page 140

“Heating Capacity Table” on page 141

“External Static Pressure” on page 142

“Acoustic Data” on page 143

“Refrigerant Flow Diagram” on page 144

“Wiring Diagram” on page 145

“Factory Supplied Parts and Materials” on page 147

“Installation and Best Layout Practices” on page 148

Two-way Vertical-Horizontal Air Handling Indoor Unit

General

All LG indoor units are factory assembled, wired, piped, and provided with a control circuit board, fan, and motor. Vertical-Horizontal Air Handling units are designed for high-speed air volume against an external static pressure up to 1.00"WG. Supply air opening is flanged to accept field-installed ductwork that cannot exceed the external static pressure limit of the unit.

Coil

Indoor unit coils are factory built and are comprised of aluminum fins mechanically bonded to copper tubing. Each unit has a minimum of two rows of coils, which are pressure tested at the factory. Each unit is provided with a factory installed condensate drain pan below the coil.

Refrigerant System

System is designed for use with R410A refrigerant. The refrigeration circuit is pressure-tested at the factory and shipped with a holding charge of helium gas. Refrigerant pipe connections are 45° flare, and all refrigerant lines from the outdoor unit to the indoor units must be field insulated.

Electrical

Each indoor unit is designed to operate using 208–230/60/1 power with voltage variances of ±10%.

Casing

The casing is designed to mount fully concealed behind a wall or above a finished ceiling. Casing is manufactured of 22-gauge pre-coated metal and finished with a high-gloss baked enamel finish. Cold surfaces of the unit are covered internally with 1/2-inch polystyrene fiber insulation; inside surface of the pan assembly door access panel is treated with 1/2-inch polystyrene fiber insulation, encapsulated on both sides. The access panel is sealed along the edges with reinforced foil-faced covering, all access panels also have gasket seals to minimize air leaks.

The two-way vertical-horizontal air handling unit can operate in one of two airflow configurations: the vertical (upflow) configuration or horizontal (left) end discharge. Supply air is drawn from the top, and there is a dedicated bottom vertical return. Unit is also designed to accept an internal, optional LG electrical strip heater.

Fan Assembly and Control

The units have an integral fan assembly consisting of galvanized

Features

- Inverter (Variable speed fan)
- Control lock function
- Auto operation
- Dehumidifying function
- Two thermistor control
- Group control
- External static pressure control
- Self-diagnostics function
- Wired thermostat included

steel housing and a forward curve fan wheel. The fan motor is a brushless digitally controlled (BLDC) motor with permanently lubricated and sealed ball bearings. The fan / motor assembly is mounted on vibration-attenuating rubber grommets. Fan speed is controlled using a microprocessor-based direct digital control algorithm. The indoor fan has Low, Med, High, and Auto settings for Cooling mode; and has Low, Med, High, and Auto settings for Heating mode. Each of the settings can be field-adjusted from the factory setting (RPM / ESP). The Auto setting adjusts the fan speed to most effectively achieve setpoint.

Figure 191: Multi F Vertical-Horizontal Air Handling Indoor Unit.



Vertical-Horizontal Air Handling

Filter Assembly

The unit includes a filter rack that can accept a field-supplied 16" x 20" x 1" filter cartridge. The filter rack has a guide to assist in centering the filters, and can be accessed from the front.

Microprocessor Control

The indoor unit is provided with an integrated control panel to communicate with the outdoor unit. All unit operation parameters are stored in non-volatile memory resident on the unit microprocessor. The microprocessor controls space temperature through using the value provided by temperature sensors within the indoor unit. A field-supplied communication cable must be installed to connect the indoor unit(s) to the outdoor unit.

Controls

The indoor unit is supplied with an LG wired controller. Communication between the indoor units and the outdoor unit is accomplished through 18 AWG, four-core, stranded and shielded power / communication cable.

Condensate

The unit is designed for gravity draining of condensate.

TWO-WAY VAHU INDOOR UNITS

General Data / Specifications

MULTI F
MULTI F MAX

Table 77: Multi F Vertical-Horizontal Air Handling Indoor Unit General Data.

Model Name	LMVN240HV	LMVN360HV
Nominal Cooling Capacity (Btu/h) ¹	24,000	36,000
Nominal Heating Capacity (Btu/h) ¹	27,000	40,000
<i>Operating Range</i>		
Cooling (°F WB)	57-77	57-77
Heating (°F DB)	59-81	59-81
<i>Fan</i>		
Type	Sircocco	Sircocco
Motor Output (W) x Qty.	96 x 1	182 x 1
Motor/Drive	Brushless Digitally Controlled / Direct	Brushless Digitally Controlled / Direct
Airflow Rate CFM (H/M/L) at 0.5"WG ESP	710 / 640 / 480	990 / 880 / 800
Maximum External Static Pressure (in. WG)	1.00	1.00
<i>Unit Data</i>		
Refrigerant Type ²	R410A	R410A
Refrigerant Control	EEV	EEV
Power Supply V, Ø, Hz ³	208-230, 1, 60	208-230, 1, 60
Rated Amps (A)	0.59	1.12
Sound Pressure Level ±3 dB(A) (H/M/L) ⁴ at 0.3"WG ESP	43 / 42 / 41	45 / 44 / 43
Dimensions (W x H x D, in.)	18 x 48-21/32 x 21-1/4	18 x 48-21/32 x 21-1/4
Net Weight (lbs.)	117	121
Shipping Weight (lbs.)	130	135
Power Wiring / Communications Cable (No. x AWG) ⁵	4 x 18	4 x 18
Heat Exchanger (Row x Column x Fin / inch) x Number	(2 x 24 x 18) x 2	(3 x 24 x 18) x 2
<i>Piping</i>		
Liquid (in.)	1/4	3/8
Vapor (in.)	1/2	5/8
Primary Drain I.D. (in.)	3/4 FPT	3/4 FPT
Secondary Drain I.D. (in.)	3/4 FPT	3/4 FPT

¹Nominal capacity is rated 0 ft. above sea level with corresponding refrigerant piping length in accordance with standard length of each outdoor unit and a 0 ft. level difference between outdoor and indoor units. All capacities are net with a combination ratio between 95 – 105%.

Nominal cooling capacity rating obtained with air entering the indoor unit at 80°F dry bulb (DB) and 67°F wet bulb (WB) and outdoor ambient conditions of 95°F dry bulb (DB) and 75°F wet bulb (WB).
Nominal heating capacity rating obtained with air entering the indoor unit at 70°F dry bulb (DB) and 60°F wet bulb (WB) and outdoor ambient conditions of 47°F dry bulb (DB) and 43°F wet bulb (WB).

²This unit comes with a dry helium charge.

³Acceptable operating voltage: 187V-253V.

⁴Sound pressure levels are tested in an anechoic chamber under ISO Standard 3745 and are the same in both cooling and heating mode. These values can increase due to ambient conditions during operation.

⁵All power wiring / communications cable to the IDUs must be minimum 18 AWG, 4-conductor, stranded, shielded or unshielded (if shielded, must be grounded to chassis at ODU only) and must comply with applicable local and national codes.

Figure 192: LMVN240HV and LMVN360HV Dimensions.

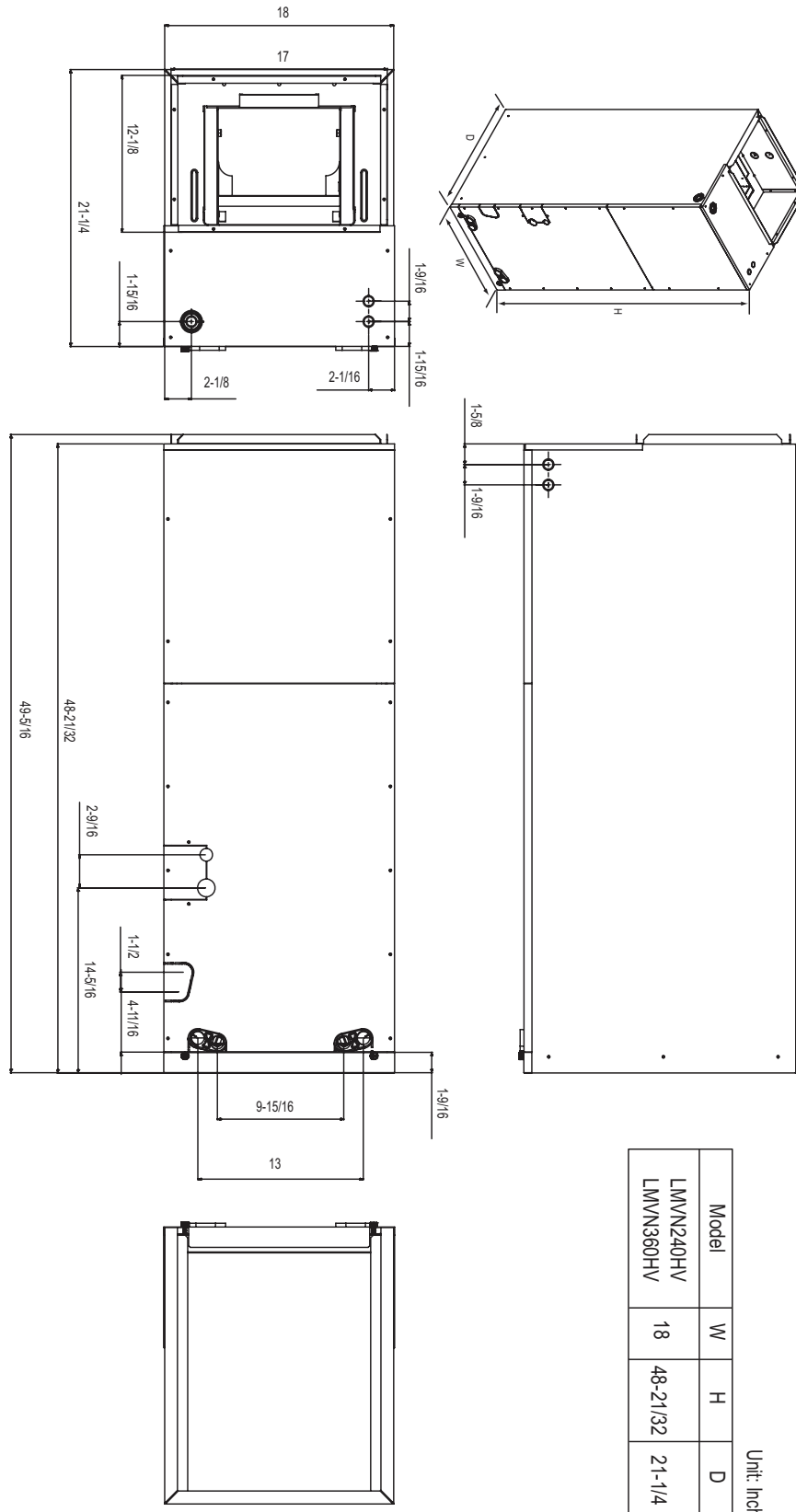

TWO-WAY VAHU INDOOR UNITS

Cooling Capacity Table

MULTI F
MULTI F MAX

Table 78: Multi F Vertical-Horizontal Air Handling Indoor Units Cooling Capacity Table.

Model No. / Nominal Capacity of Indoor Unit (Btu/h)	Outdoor Air Temp. (°F DB)	Indoor Air Temp. °F DB / °F WB											
		68 / 57		73 / 61		77 / 64		80 / 67		86 / 72		90 / 75	
		TC	SHC	TC	SHC	TC	SHC	TC	SHC	TC	SHC	TC	SHC
LMVN240HV 24,000	14	23.53	17.89	24.99	18.90	26.45	18.30	27.50	18.69	29.37	18.84	30.83	19.20
	20	23.51	18.03	24.97	19.05	26.43	18.44	27.48	18.83	29.35	18.99	30.81	19.35
	25	23.49	18.17	24.95	19.20	26.41	18.59	27.46	18.98	29.33	19.14	30.79	19.50
	30	23.47	18.31	24.93	19.34	26.39	18.73	27.44	19.12	29.30	19.28	30.76	19.65
	35	23.46	18.45	24.91	19.49	26.37	18.87	27.42	19.27	29.28	19.43	30.74	19.80
	40	23.44	18.59	24.89	19.64	26.35	19.01	27.40	19.41	29.26	19.58	30.72	19.95
	45	23.42	18.73	24.87	19.78	26.33	19.15	27.38	19.56	29.24	19.72	30.69	20.10
	50	23.40	18.87	24.85	19.93	26.31	19.30	27.36	19.70	29.21	19.87	30.67	20.24
	55	23.38	19.00	24.84	20.07	26.29	19.44	27.34	19.85	29.19	20.01	30.64	20.39
	60	23.37	19.14	24.82	20.22	26.27	19.58	27.32	19.99	29.17	20.16	30.62	20.54
	65	23.35	19.28	24.80	20.37	26.25	19.72	27.29	20.13	29.15	20.30	30.60	20.69
	70	23.33	19.42	24.78	20.51	26.23	19.86	27.27	20.28	29.13	20.45	30.57	20.84
	75	22.77	19.10	24.21	20.20	25.66	19.58	26.70	20.01	28.55	20.20	29.99	20.60
	80	22.21	18.77	23.65	19.88	25.09	19.30	26.13	19.73	27.97	19.95	29.42	20.36
	85	21.65	18.43	23.09	19.55	24.53	18.99	25.57	19.44	27.40	19.68	28.84	20.10
	90	21.09	18.08	22.53	19.21	23.96	18.69	25.00	19.14	26.83	19.40	28.27	19.84
	95	20.49	17.89	21.92	19.03	23.35	18.55	24.00	18.72	26.20	19.30	27.63	19.75
	100	19.99	17.41	21.42	18.55	22.85	18.10	23.69	18.43	25.70	18.88	27.13	19.35
105	19.49	16.93	20.92	18.07	22.35	17.66	23.38	18.14	25.20	18.47	26.63	18.94	
110	18.99	16.35	20.42	17.49	21.85	17.12	22.88	17.60	24.70	17.94	26.13	18.42	
115	18.49	15.86	19.92	17.00	21.35	16.66	22.38	17.15	24.20	17.51	25.63	18.00	
118	18.19	15.75	19.62	16.89	21.05	16.58	22.08	17.07	23.90	17.46	25.33	17.96	
122	18.10	15.71	19.52	16.86	20.95	16.55	21.98	17.05	23.81	17.44	25.23	17.94	
LMVN360HV 36,000	14	35.29	26.84	37.48	28.35	39.67	27.45	41.26	28.03	44.06	28.26	46.25	28.80
	20	35.26	27.05	37.45	28.57	39.64	27.66	41.23	28.25	44.02	28.49	46.21	29.02
	25	35.24	27.26	37.43	28.79	39.61	27.88	41.19	28.47	43.99	28.71	46.18	29.25
	30	35.21	27.47	37.40	29.01	39.58	28.09	41.16	28.68	43.96	28.93	46.14	29.47
	35	35.18	27.67	37.37	29.23	39.55	28.31	41.13	28.90	43.92	29.15	46.11	29.70
	40	35.16	27.88	37.34	29.45	39.52	28.52	41.10	29.12	43.89	29.37	46.07	29.92
	45	35.13	28.09	37.31	29.67	39.49	28.73	41.07	29.34	43.86	29.58	46.04	30.14
	50	35.10	28.30	37.28	29.89	39.46	28.94	41.04	29.55	43.82	29.80	46.00	30.37
	55	35.08	28.51	37.25	30.11	39.43	29.16	41.01	29.77	43.79	30.02	45.97	30.59
	60	35.05	28.71	37.23	30.33	39.40	29.37	40.97	29.99	43.76	30.24	45.93	30.81
	65	35.02	28.92	37.20	30.55	39.37	29.58	40.94	30.20	43.72	30.46	45.90	31.03
	70	34.99	29.13	37.17	30.77	39.34	29.79	40.91	30.42	43.69	30.67	45.86	31.26
	75	34.15	28.65	36.32	30.30	38.49	29.37	40.05	30.01	42.82	30.30	44.99	30.90
	80	33.31	28.16	35.47	29.82	37.64	28.94	39.20	29.60	41.96	29.92	44.12	30.54
	85	32.48	27.64	34.63	29.32	36.79	28.49	38.35	29.16	41.10	29.52	43.26	30.15
	90	31.64	27.12	33.79	28.81	35.94	28.03	37.50	28.71	40.25	29.10	42.40	29.76
	95	30.74	26.84	32.88	28.55	35.02	27.82	36.00	28.08	39.30	28.95	41.44	29.63
	100	29.99	26.12	32.13	27.83	34.27	27.15	35.53	27.65	38.55	28.32	40.69	29.02
105	29.24	25.40	31.38	27.11	33.52	26.49	35.07	27.21	37.80	27.70	39.94	28.41	
110	28.49	24.53	30.63	26.23	32.77	25.67	34.32	26.40	37.05	26.92	39.20	27.64	
115	27.74	23.80	29.88	25.49	32.02	24.99	33.57	25.72	36.31	26.27	38.45	27.01	
118	27.29	23.62	29.43	25.34	31.57	24.87	33.12	25.61	35.86	26.18	38.00	26.93	
122	27.14	23.56	29.28	25.29	31.43	24.82	32.97	25.57	35.71	26.15	37.85	26.91	

TC = Total Capacity (kBtu/h).

SHC: Sensible Heat Capacity (kBtu/h).

Nominal capacity as rated 0 ft. above sea level and a 0 ft. level difference between outdoor and indoor units. Corresponding refrigerant piping length is accordance with standard length of each outdoor unit.

Nominal cooling capacity rating obtained with air entering the indoor unit at 80°F dry bulb (DB) and 67°F wet bulb (WB), and outdoor ambient conditions of 95°F dry bulb (DB) and 75°F wet bulb (WB).

The shaded table columns and rows indicate reference data. When operating at this temperature, these values can be different if the system is not running consistently.

Multi F and Multi F MAX Indoor Unit Engineering Manual

Table 79: Multi F Vertical-Horizontal Air Handling Indoor Units Heating Capacity Table.

Model No. / Nominal Capacity of Indoor Unit (Btu/h)	Outdoor Air Temp.		Indoor Air Temp. °F DB					
	°F DB	°F WB	61	64	68	70	72	75
			TC	TC	TC	TC	TC	TC
LMVN240HV 24,000	0	-0.4	13.89	13.70	13.57	13.50	13.30	12.72
	5	4.5	15.65	15.46	15.33	15.26	15.07	14.48
	10	9	17.41	17.22	17.09	17.02	16.83	16.24
	17	15	19.76	19.57	19.43	19.37	19.17	18.55
	20	19	20.64	20.45	20.32	20.25	20.05	19.37
	25	23	22.11	21.91	21.78	21.72	21.52	20.74
	30	28	23.38	23.18	23.05	22.99	22.79	22.11
	35	32	24.65	24.46	24.33	24.26	24.07	23.48
	40	36	25.79	25.60	25.47	25.40	25.21	24.62
	45	41	26.93	26.74	26.61	26.54	26.35	25.76
	47	43	27.39	27.20	27.07	27.00	26.80	26.22
	50	46	27.83	27.64	27.51	27.44	27.24	26.58
	55	51	28.57	28.37	28.24	28.17	27.98	27.20
	60	56	28.57	28.37	28.24	28.17	27.98	27.32
63	59	28.57	28.37	28.24	28.17	27.98	27.39	
68	64	28.57	28.37	28.24	28.17	27.98	27.51	
LMVN360HV 36,000	0	-0.4	20.58	20.29	20.10	20.00	19.71	18.84
	5	4.5	23.19	22.90	22.71	22.61	22.32	21.45
	10	9	25.80	25.51	25.31	25.22	24.93	24.06
	17	15	29.28	28.99	28.79	28.70	28.41	27.48
	20	19	30.58	30.29	30.10	30.00	29.71	28.70
	25	23	32.75	32.46	32.27	32.17	31.88	30.72
	30	28	34.64	34.35	34.15	34.06	33.77	32.75
	35	32	36.52	36.23	36.04	35.94	35.65	34.78
	40	36	38.21	37.92	37.73	37.63	37.34	36.47
	45	41	39.90	39.61	39.42	39.32	39.03	38.16
	47	43	40.58	40.29	40.10	40.00	39.71	38.84
	50	46	41.23	40.94	40.75	40.65	40.36	39.38
	55	51	42.32	42.03	41.84	41.74	41.45	40.29
	60	56	42.32	42.03	41.84	41.74	41.45	40.47
63	59	42.32	42.03	41.84	41.74	41.45	40.58	
68	64	42.32	42.03	41.84	41.74	41.45	40.76	

TC = Total Capacity (kBtu/h).

Nominal capacity as rated 0 ft. above sea level and a 0 ft. level difference between outdoor and indoor units. Corresponding refrigerant piping length is accordance with standard length of each outdoor unit. Nominal heating capacity rating obtained with air entering the indoor unit at 70°F dry bulb (DB) and 60°F wet bulb (WB), and outdoor ambient conditions of 47°F dry bulb (DB) and 43°F wet bulb (WB).

Vertical-Horizontal Air Handling

TWO-WAY VAHU INDOOR UNITS

External Static Pressure

MULTI F
MULTI F MAX

Table 80: Multi F Vertical-Horizontal Air Handling Unit External Static Pressure Setting Values Table.

Static Pressure (in. wg)			0.1	0.2	0.3	0.4	0.5	0.6	0.7	0.8	0.9	1.0
Model No. / Nominal Capacity of Indoor Unit (Btu/h)	Airflow Rate / CFM		Setting Value at (in. wg) ¹									
	LMVN240HV 24,000	High	710	56	67	74	78	87	94	98	98 ²	98 ²
Mid		640	53	65	70	75	85	91	96	96 ²	96 ²	96 ²
Low		480	53	55	64	70	79	84	92	92 ²	92 ²	92 ²
LMVN360HV 36,000	High	990	80	85	90	95	100	103	103 ²	103 ²	103 ²	103 ²
	Mid	880	65	72	80	85	92	98	103	103 ²	103 ²	103 ²
	Low	800	65	69	77	82	90	96	101	101 ²	101 ²	101 ²

¹Unless otherwise noted, vertical-horizontal air handling units are UL listed up to 0.5 in. wg total static pressure, including coil, case, duct work pressure drop, air filter, and largest kW size heater. Internal static pressure includes coil and case only.

²Airflow rate (CFM) decreases by 3% per 0.1 in. wg.

³Maximum airflow rate is 400 CFM per ton. (For the 24,000 Btu/h unit, the maximum airflow rate is 2 x 400 = 800 CFM). If airflow is set at the maximum rate, the external static pressure value must be increased from high speed setting value to: From 24kBtu/h of capacity: 4; From 36kBtu/h of capacity: 5

⁴High static pressure is 0.5 in. wg (factory setting); low static pressure is 0.3 in. wg.

Note:

If external static pressure is not set correctly, the air conditioning system may not operate properly or may malfunction.

Table 81: Multi F Vertical-Horizontal Air Handling Unit Minimum Airflow by Heater Capacity.

Model No. / Nominal Capacity of Indoor Unit (Btu/h)	Heater Capacity (kW)			
	5	10	15	20
LMVN240HV (24,000)	480 CFM	480 CFM	Not Available	Not Available
LMVN360HV (36,000)	780 CFM	780 CFM	Not Available	Not Available

⚠ WARNING

⊘ Do not operate the air conditioning system using less than the minimum airflow. There is risk of fire and severe injury or death.

Note:

⊘ Do not operate the air conditioning system using less than the minimum airflow. There is risk of product damage.

Table 82: Electric Heater Static Pressure Drop.

Heater Capacity (kW)	Static Pressure Drop (in. wg)
0	0
5	-0.01
10	-0.02

Note:

- The external static pressure value must be reset if an electric heater is installed. For each 0.01 in. wg. increase in static pressure, the external static pressure must increase by 1.
- If the external static pressure is not set properly, the provided safety device will turn off the heater (according to airflow).

Table 83: Field-Supplied Air Filter Static Pressure Drop Factors.

Model No. / Nominal Capacity of Indoor Unit (Btu/h)	Airflow Rate / CFM		Static Pressure Drop (in. wg)
LMVN240HV (24,000)	High	710	-0.04
	Mid	640	-0.03
	Low	480	-0.03
LMVN360HV (36,000)	High	990	-0.07
	Mid	880	-0.05
	Low	800	-0.05

Note:

- The external static pressure value must be reset if an air filter is installed. For each 0.01 in. wg. increase in static pressure, the external static pressure must increase by 1.
- Factory tested with MERV 4 filter media. Fan speed set value when the unit is used with field-supplied filter media.

Figure 193: Sound Pressure Level Measurement Location.

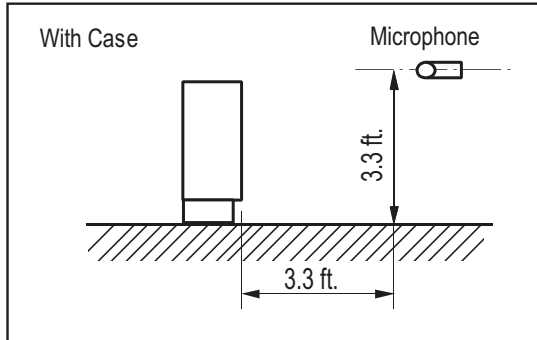

- Measurement taken 3.3' away from the unit.
- Measurements taken with no attenuation and units operating at full load normal operating condition.
- Sound level will vary depending on a range of factors such as construction (acoustic absorption coefficient) of particular area in which the equipment is installed.
- Sound power levels are measured in dB(A)±3.
- Tested in anechoic chamber per ISO Standard 3745.

Table 84: Sound Pressure Levels (dB[A]).

Model No.	Sound Pressure Levels (dB[A]) (Cooling and Heating)		
	High Fan Speed	Medium Fan Speed	Low Fan Speed
LMVN240HV	43	42	41
LMVN360HV	45	44	43

Figure 194: Sound Pressure Level Diagrams.

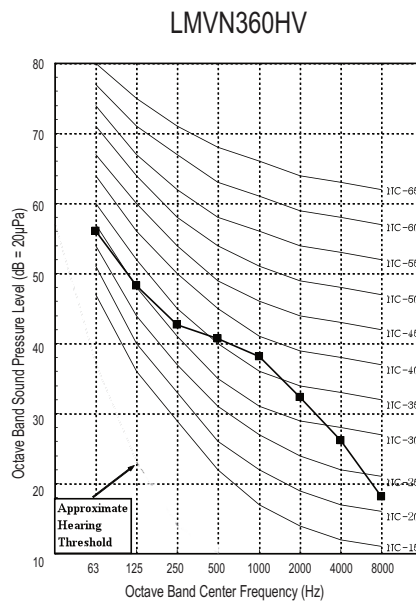
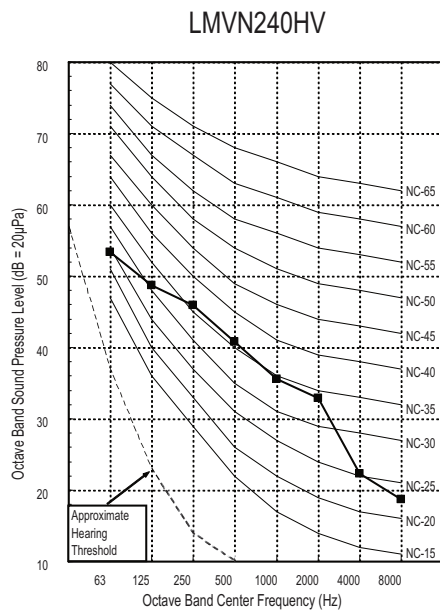

TWO-WAY VAHU INDOOR UNITS

Refrigerant Flow Diagram

MULTI F
MULTI F MAX

Figure 195: Multi F Vertical-Horizontal Air Handling Indoor Unit Refrigerant Flow Diagram.

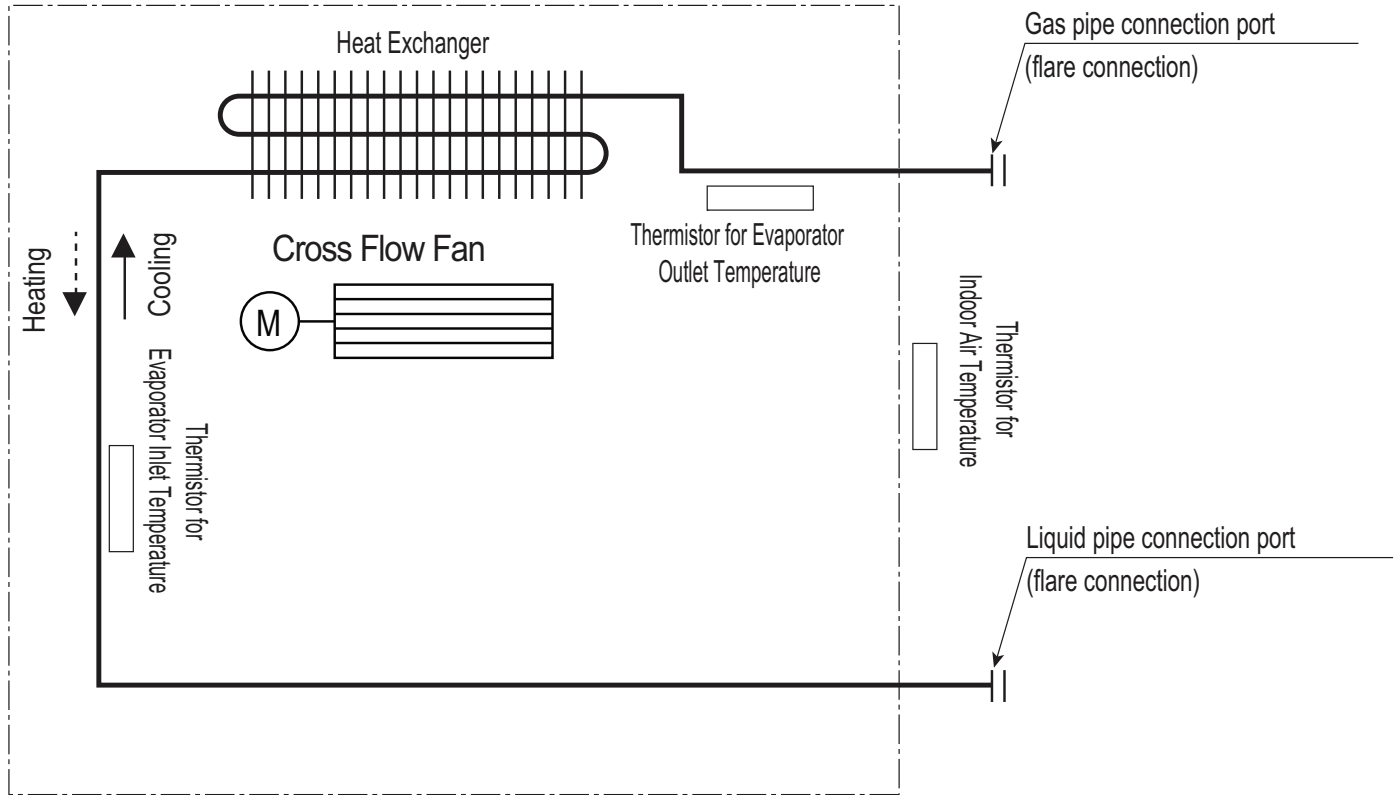

Table 85: Multi F Vertical-Horizontal Air Handling Indoor Unit Refrigerant Pipe Connection Port Diameters.

Model No.	Vapor (inch)	Liquid (inch)
LMVN240HV	1/2	1/4
LMVN360HV	5/8	3/8

Table 86: Multi F Vertical-Horizontal Air-Handling Indoor Unit Thermistor Details.

Description (Based on Cooling Mode)	PCB Connector
Indoor Air Temperature Thermistor	CN-ROOM
Evaporator Inlet Temperature Thermistor	CN-PIPE/IN
Evaporator Outlet Temperature Thermistor	CN-PIPE/OUT

Figure 196: Multi F Vertical-Horizontal Air-Handling Indoor Unit Wiring Diagram.

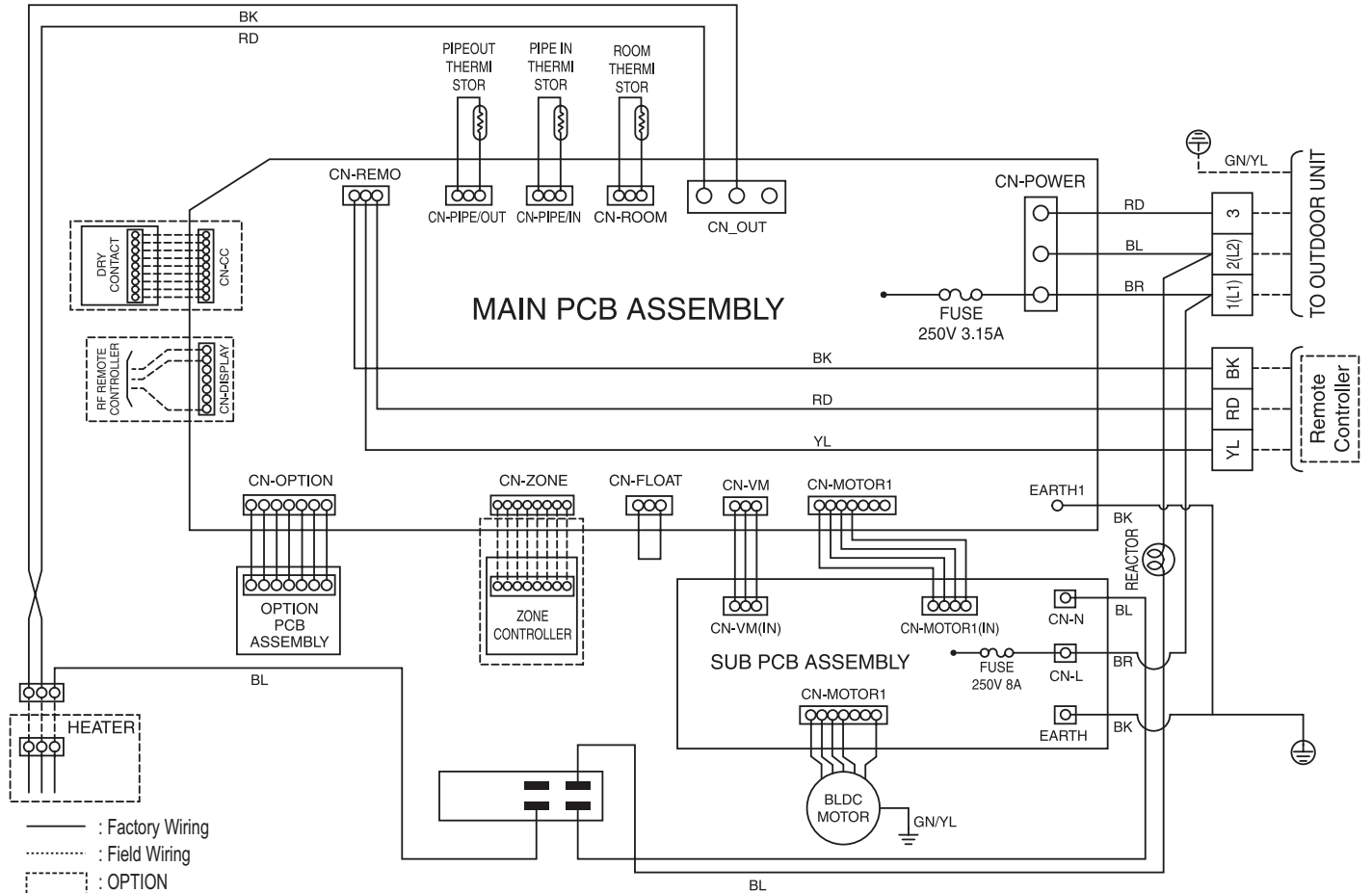

Table 87: Wiring Diagram Connections.

Connection Name	Location	Function
CN-POWER	AC power supply	AC Power line input for indoor controller
CN-MOTOR1	Fan motor output	Motor output of BLDC
CN-MOTOR2	Fan motor output	Motor output of BLDC
CN-FLOAT	Float switch input	Float switch sensing (water level sensor)
CN-PIPE/IN	Suction pipe sensor	Pipe in thermistor
CN-PIPE/OUT	Discharge pipe sensor	Pipe out thermistor
CN-ROOM	Room sensor	Room thermistor
CN-REMO	Remote controller	Remote control line
CN-OPTION	Option PCB	Communication between main and option
CN-ZONE	Zone controller	Zone control line
CN-DISPLAY	RF Remote controller	RF Remote control line
CN-CC	Dry contact	Dry contact line

TWO-WAY VAHU INDOOR UNITS

Wiring Diagram

MULTI F
MULTI F MAX

Table 88: DIP Switch Settings.

Dip Switch Settings		OFF	ON	Description
SW3	GROUP	Master	Slave	Group control setting using wired remote controller.
SW4	DRY CONTACT	Variable	Auto	Dry contact mode setting. 1. Variable: Auto/manual mode can be chosen using the wide wired remote controller or wireless remote controller (factory setting is the manual mode). 2. Auto: For dry contact, it is always auto mode.
SW5	EXTRA1	Off	On	<ul style="list-style-type: none"> • ON: Fan operates continuously. • OFF: Default (Fan does not operate continuously).
SW6	HEATER	Off	On	<ul style="list-style-type: none"> • ON: Automatic heater operation. • OFF: Default (manual heater operation).

- Indoor unit without electric heater.
 - DIP switch 1, 2, 6, 8 must be set to OFF.
- Indoor unit with electric heater, DIP switches 5 and 6 must be set to ON.
 - SW 5 ON: Fan operates continuously. (Can have uninterrupted heating during defrost or oil return modes using continuous heater and fan operation.)
 - SW5 OFF: Fan discontinuous operation. (There would be reduction in heating capacity while defrosting or oil return operation.)
 - SW6 ON: Automatic heater operation. (Heater operates automatically using the heater algorithm.)
 - SW6 OFF: Manual heater operation. (On / off operation is set manually. Heater operation follows the heater algorithm.)

Factory Supplied Materials

- Owner's Manual
- Installation Manual
- Simple Controller with Mode Selection (AKB72955816)¹

¹Simple Mode Controllers for the vertical-horizontal air handling indoor units are also referenced by Model No. PQRCVCL0QW.

Required Tools

- Level
- Screwdriver
- Electric drill
- Hole core drill
- Flaring tool set
- Torque wrenches
- Hexagonal wrench
- Gas-leak detector
- Thermometer

⚠ WARNING

Installation work must be performed by trained personnel and in accordance with national wiring standards and all local or other applicable codes. Improper installation can result in fire, electric shock, physical injury, or death.

Note:

Read all instructions before installing this product. Become familiar with the unit's components and connections, and the order of installation. Incorrect installation can degrade or prevent proper operation.

Selecting the Best Location

Do's

- Place the unit where air circulation through the ducts will not be blocked.
- Place the unit where drainage can be obtained easily.
- Place the unit where noise prevention is taken into consideration.
- Ensure there is sufficient strength to bear the load of the indoor unit.
- Ensure there is sufficient maintenance space.
- Locate the indoor unit in a location that is level, and where it can be easily connected to the outdoor unit / branch distribution unit.

Note:

If the unit is installed near a body of water, certain components are at risk of being corroded. Appropriate anti-corrosion methods should be taken for the unit and all components.

Volatile Organic Compounds

Indoor Units (IDUs) should not be placed in an environment where the IDUs may be exposed to harmful volatile organic compounds (VOCs) or in environments where there is improper air make up or supply or inadequate ventilation. If there are concerns about VOCs in the environment where the IDUs are installed, proper air make up or supply and/ or adequate ventilation should be provided. Additionally, in buildings where IDUs will be exposed to VOCs consider a factory-applied epoxy coating to the fan coils for each IDU.

Installing in an Area Exposed to Unconditioned Air

In some installation applications, areas (floors, walls) in some rooms may be exposed to unconditioned air (room may be above or next to an unheated garage or storeroom). To countermeasure:





- Verify that carpet is or will be installed (carpet may increase the temperature by three degrees).
- Add insulation between the floor joists.
- Install radiant heat or another type of heating system to the floor.

Installing in an Area with High Humidity Levels

If the environment is prone to humidity levels of 80% or more (near the ocean, lakes, etc.) or where steam could collect in the plenum:

- Install additional insulation to the indoor unit (glass wool insulation >13/32 inches thick).
- Install additional insulation to the refrigerant piping (insulation >13/16 inches thick).
- Seal all gaps between the indoor unit and the ceiling tiles (make the area air tight) so that humidity does not transfer from the plenum to the conditioned space. Also, add a ceiling grille for ventilation.

Don'ts

-  Do not install the unit near a heat or steam source, or where considerable amounts of oil, iron powder, or flour are used.
-  Do not install the unit where sulfuric acid and flammable or corrosive gases are generated, vented into, or stored.
-  Do not install the unit near high-frequency generators.
-  Do not install the unit near a doorway.

The unit may be damaged, may malfunction, and/or will not operate as designed if installed in any of the conditions listed.

TWO-WAY VAHU INDOOR UNITS

Installation and Best Layout Practices

MULTI F
MULTI F MAX

Figure 197: Clearance Requirements.

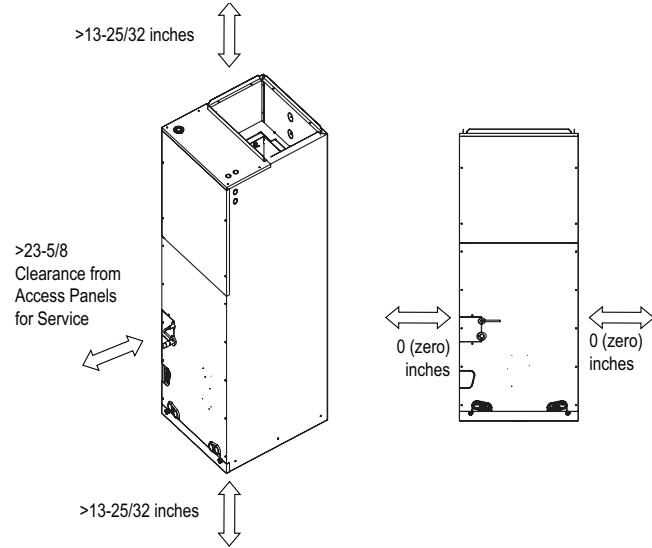

Figure 198: General and Duct Connection Dimensions.

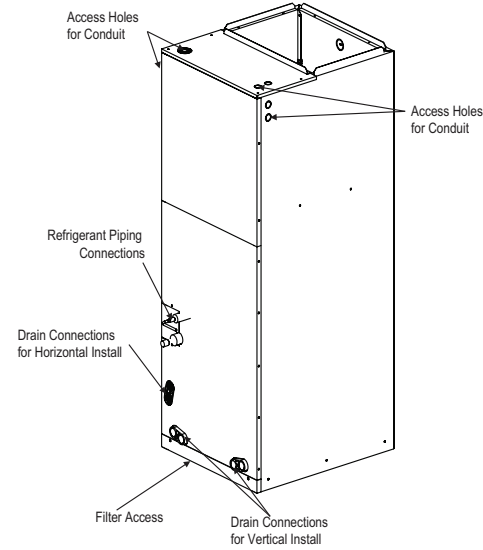

Figure 199: Location of Access Holes and Piping Connections.

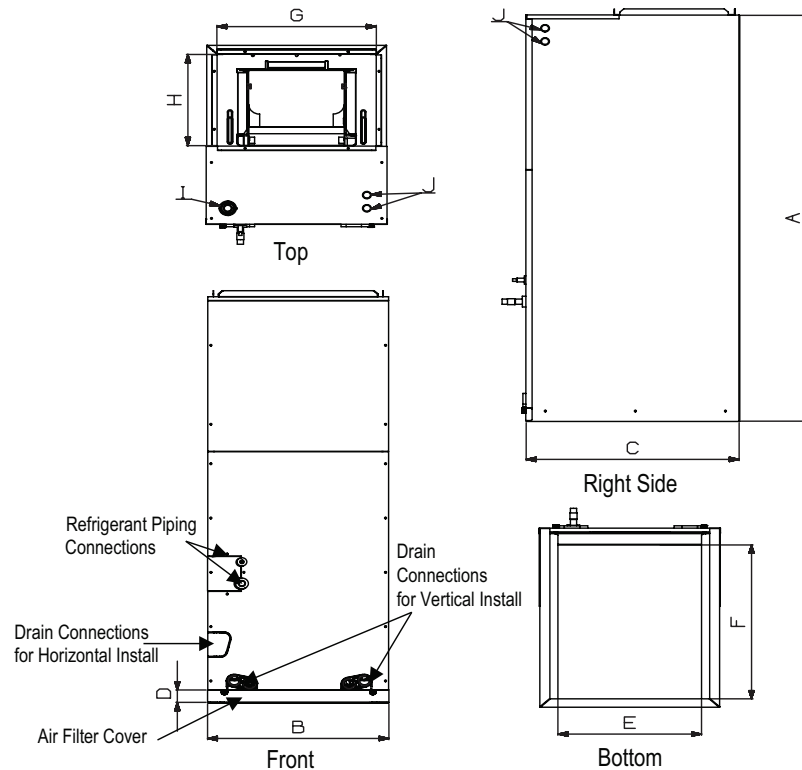

Table 89: General and Duct Connection Dimensions.

Capacity (Btu/h)	Dimensions (inches)								Access Hole for Wiring / Cable (inches)		Refrigerant Connection Sizes (inches)	
	A	B	C	D	E	F	G	H	I	J	Liquid	Vapor
	Height	Width	Depth						Power	Comm.		
24,000	48-21/32	18	21-1/4	1-9/16	17-1/2	20	17	12-1/8	1-11/16	7/8	1/4	1/2
36,000											3/8	5/8

Note:

Vertical-Horizontal Air Handling Units can be installed in a choice of vertical (upflow) or horizontal (left side) configurations.

Vertical (Upflow) Installation

- Unit must be positioned properly for plenum / duct installation.
- To maintain proper air flow, minimum height clearance is 14 inches.
- Plenum must be strong and secure enough to support the installation of adapter collars to accommodate duct work.
- Air handler platform should be sturdy enough to support the frame, plus any accessories (e.g., filter box).
- To prevent air leaks, seal all duct work according to local codes, but make sure that filter access is still unobstructed.
- Vibration isolators (field supplied) must be installed between the unit frame and the platform. If necessary, provide the installing contractor with an illustration of where the vibration isolator should be added and how it should be positioned.

Figure 200: Vertical Installation / Attaching the Bottom Duct.

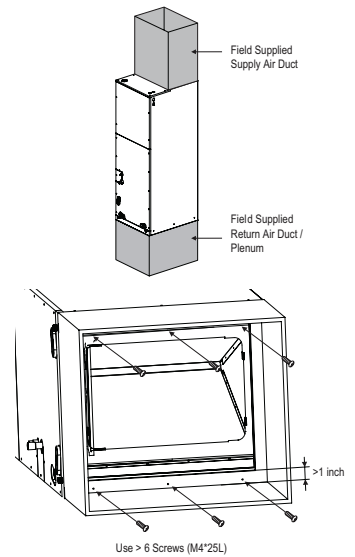

Note:

⊘ Do not install the screws on the front and back of the unit, doing so may block filter installation.

Horizontal Installation

- Units must be installed so that the access panels face to the side, not facing up or down.
- Installation must be in accordance with all relevant building codes, which may necessitate the installation of an external condensate pan (position the unit in or above the external condensate pan).
- If the units are going to be suspended, use angled steel support brackets with threaded rods to provide support from the bottom. The brackets / threaded rods should be comparatively bigger / longer than the unit, and each must be centered on the part of the frame it supports.
- If the unit will not be suspended, still use angled steel support brackets, but also add vibration isolators (field supplied) to avoid sound transmission. If necessary, provide the installing contractor with an illustration of where the vibration isolator should be added and how it should be positioned.

Figure 201: Horizontal Installation.

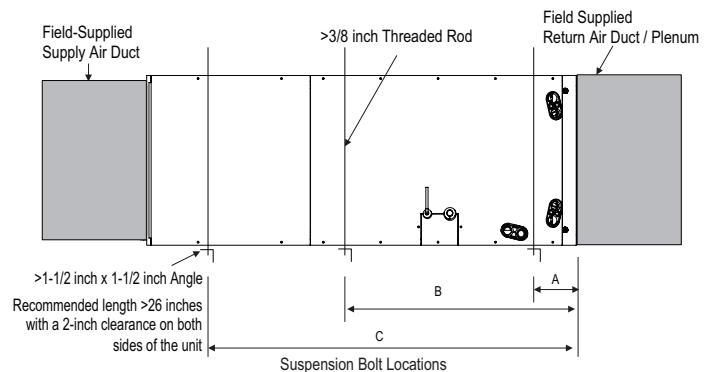

Table 90: Bracket / Bolt Position Dimensions.

Capacity (Btu/h)	Dimensions (inches)		
	A	B	C
24,000	4	23	41-11/32
36,000			

- Unit must be positioned properly for plenum / duct installation.
- Plenum must be strong and secure enough to support the installation of adapter collars to accommodate duct work.

Note:

To ensure proper drainage for horizontal installations, unit must be installed within ±1/8 inches level of the unit's length and width.

TWO-WAY VAHU INDOOR UNITS

Installation and Best Layout Practices

MULTI F
MULTI F MAX

Installing the Ducts

- Use more than ten (10) screws to securely attach the supply ducts to the unit. To prevent air leaks, seal around the duct opening before the duct is secure.
- To prevent vibration transmission, install flexible connectors between ducts and the unit. The flexible connectors must be made of a heat-resistant material at the discharge connection if an electric heater is installed.
- Duct work must be insulated and covered with vapor barrier when routed through unconditioned spaces. Include enough insulation to prevent condensate from forming on the ducts.
- It may be necessary to add internal acoustical insulation lining for a metal duct system if it does not include a 90° elbow and ten (10) feet between the main duct and the first branch.
- Fibrous glass ducts could be used as a substitute if built and installed in accordance with the most recent edition of the Sheet Metal and Air-Conditioning Contractors' National Associate (SMACNA) standard.
- Also, fibrous duct work and acoustical insulation lining must also follow National Fire Protection Standard 90A or B as tested by UL Standard 181 for Class 1 air ducts.

Figure 202: Securing the Ducts to the Unit.

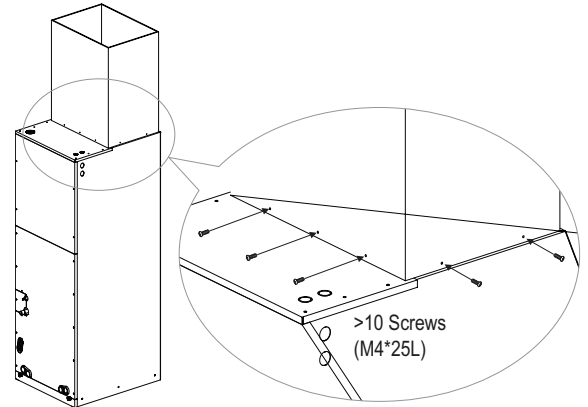

Installing the Drain System

General Specifications

- To prevent property damage, optimize drain system performance by installing both a primary and secondary drain line, and properly size the condensate traps.
- The primary and secondary drain line must be trapped to allow proper drainage of condensate water. If the secondary drain line is not used, it must be capped.
- Do not block the filter access panel when installing the condensate drain piping. Prime the primary and secondary condensate traps after running both to the drain pan.
- If the unit is installed above an inhabited space, add a field-supplied external condensate pan that runs underneath the entire frame (to prevent damage from overflow). The additional external condensate line should run from the unit to the external condensate pan.
- Drain all generated condensate from the external condensate pan to an appropriate area. Install a trap in the condensate lines as near to the indoor unit coil as possible.
- All condensate must be drained from the external condensate pan to some noticeable area.
- To prevent overflow, the outlet of each trap should be positioned below its connection to the condensate pan.
- All traps should be primed, insulated, and leak tested if located above an inhabited space.
- Use a 3/4-inch PVC male pipe thread fitting at the condensate pan connection. Tighten gently.
- Point the drain hose down for easier flow.
- Do not just use the pipe joint or PVC / CPVC piping on the indoor unit drain line connections. Use only Teflon tape.
- Design the drain system to plan for winter operation (condensate line may freeze up if condensate does not properly drain away).

Figure 203: Vertical Installation Drain System.

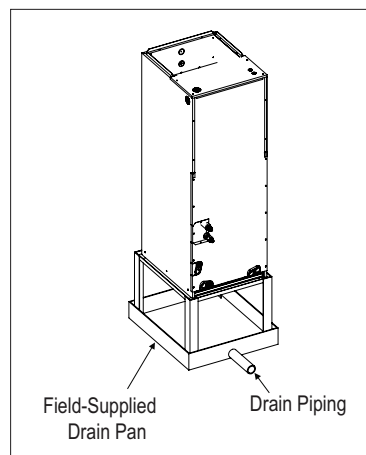
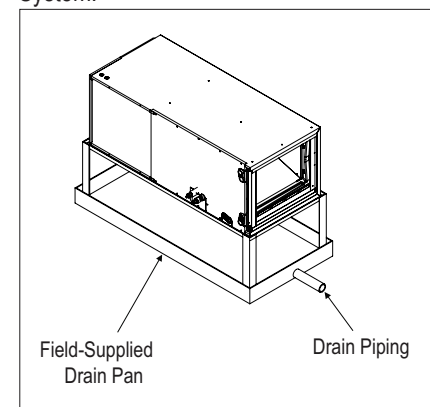

Figure 204: Horizontal Installation Drain System.



Drain Piping Specifications

- Drain piping must have downward gradient of at least 1/50 to 1/100; to prevent reverse flow, slope should not be straight up and down.
- Do not damage the drain port on the indoor unit when connecting the field-supplied drain piping.

Figure 205: Close up of Drain Piping Connection.

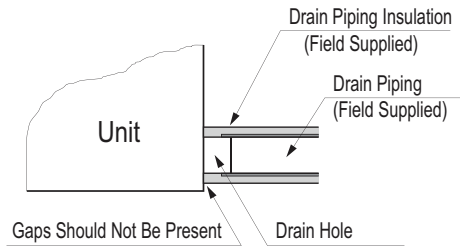

Insulating the Refrigerant and Drain Piping

⚠ WARNING

Ensure all piping is insulated. Exposed piping can cause burns if touched.

Refrigerant Piping Insulation

Field-installed vapor and liquid refrigerant piping lines must be properly and completely covered in insulation (up to the indoor unit piping connections) and must comply with federal, state, and local requirements. Any exposed piping may generate condensate or will cause burns if touched. Insulation for this field-installed refrigerant piping must have a minimum heat resistance of 248°F.

If the indoor unit is installed and is operated at an extended period in a highly humid environment (dew point temperature >73°F), however, condensate will form. To prevent this phenomenon, install adiabatic glass wool insulation with a thickness of 7/16 to 13/16 inches thick. Also, install glass wool insulation on all indoor units that are located in the ceiling plenum.

Drain Piping Insulation

Drain piping insulation must be 7/32 inches thick, minimum.

Figure 209: Close Up of Refrigerant Piping Connection Insulation.

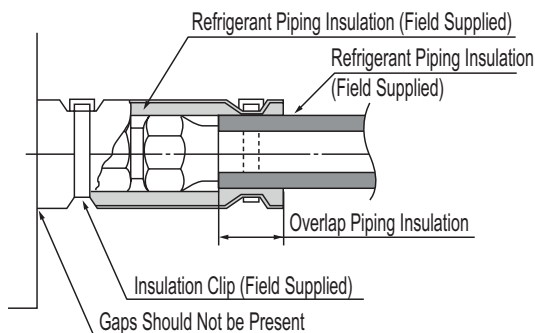

Field-Installed U-Trap Specifications

Note:

To prevent leaks cause by a block in the intake air filter, install a U-Trap.

$A \geq 2\text{-}9/16$ inches

$B \geq 2C$

$C \geq 2 \times \text{SP}$

SP = External Pressure in. WG

Example:

External Pressure = 0.4 in WG

$A \geq 2\text{-}9/16$ inches

$B \geq 1\text{-}7/12$ inches

$C \geq 19/24$ inches

Figure 206: Installing the U-Trap.

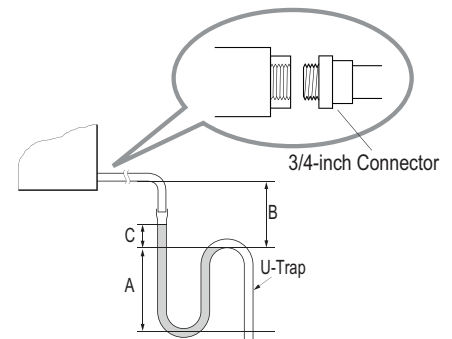

Figure 207: Vertical Primary and Secondary Drain Layout.

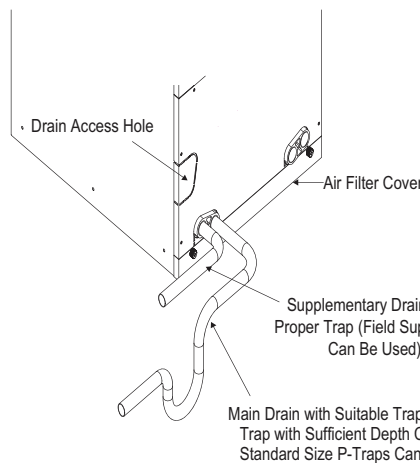

Figure 208: Horizontal Primary and Secondary Drain Layout.

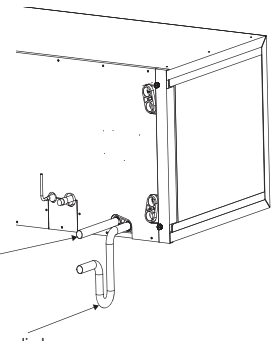
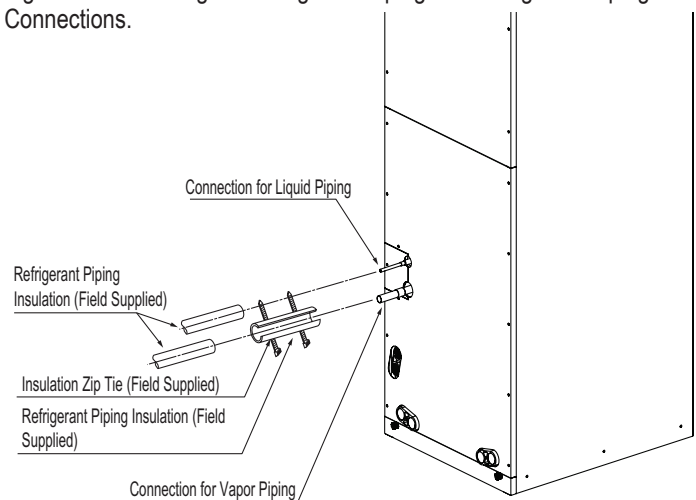

Figure 210: Insulating the Refrigerant Piping and Refrigerant Piping Connections.



TWO-WAY VAHU INDOOR UNITS

Installation and Best Layout Practices

MULTI F
MULTI F MAX

Power Wiring / Communications Cable Guidelines

- Follow manufacturer's circuit diagrams in the technical manuals.
- Confirm power source specifications.
- Confirm that the electrical capacity is sufficient.
- Starting current must be maintained ± 10 percent of the rated current marked on the outdoor unit name plate.
- Confirm cable thickness specifications.
- It is recommended that a circuit breaker is installed, especially if conditions could become wet or moist.
- Include a disconnect in the power wiring system, add an air gap contact separation of at least 1/8 inch in each active (phase) conductor.

⚠ WARNING

- Loose wiring may cause unit to malfunction, overheat, and catch fire, resulting in severe injury or death.

Note:

- Terminal screws may become loose during transport. Properly tighten the terminal connections during installation.
- A voltage drop may cause the following problems:
- Magnetic switch vibration, fuse breaks, or disturbance to the normal function of an overload protection device.
 - Compressor will not receive the proper starting current.

Connecting the Power Wiring and Communications Cable

1. To access the terminal block, first unscrew the top front panel, and then unscrew the cover from the control box.
2. Knockout the access holes for the wiring. Insert the power wiring/communications cable from the outdoor unit or branch distribution unit (Multi F MAX systems only) through the conduits, pass the conduits through the designated access holes, and then insert the conduits into the control box. To prevent electromagnetic interference and product malfunction, leave a space between the power wiring and communications cable outside of the indoor unit.
3. Connect the power wiring and communications cables to the appropriate terminals on the indoor unit control board. Verify that the color and terminal numbers from the outdoor unit or branch distribution unit (Multi F MAX systems only) wiring match the color and terminal numbers on the indoor unit.
4. Fill in any gaps around the conduit access holes with sealant to prevent foreign particles from entering the indoor unit.

Figure 211: Connecting the Power Wiring and Communications Cable.

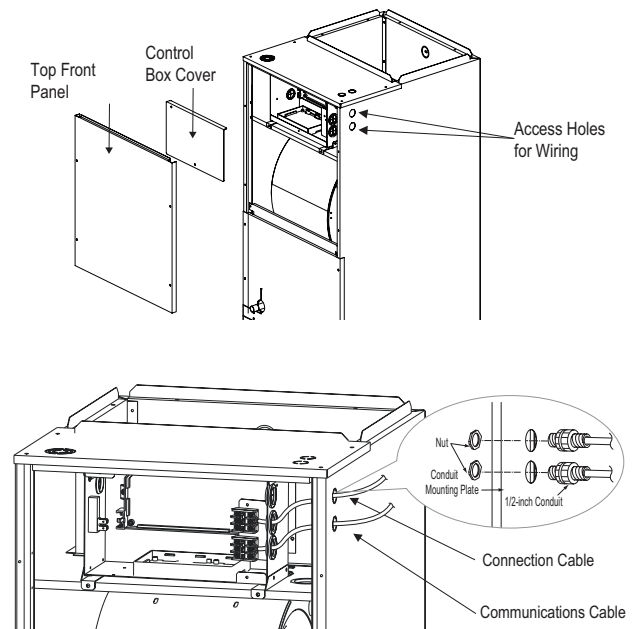
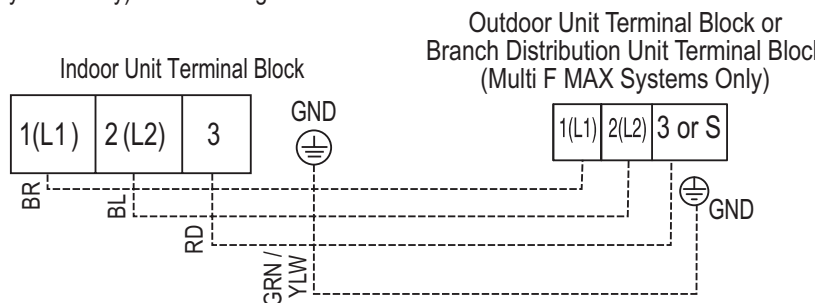

Figure 212: Indoor Unit to Outdoor Unit / Branch Distribution Unit (Multi F MAX systems only) Power Wiring / Communications Cable Connections.



Controller Options

Vertical-Horizontal Air Handling indoor units include an LG-supplied wired controller (AKB72955816)¹, but other optional LG-supplied wired controllers are available. The wireless handheld controller (Model No. PQWRHQ0FDB) is also an optional accessory with use of the wired controller.

- Operation Display Panel: Displays operation conditions.
- Temperature Control Button: Sets desired temperature.
- Fan Speed Button: Sets desired fan speed.
- On / Off Button: Turns system operation on and off.
- Mode Selection Check Button: Selects the operation mode: Cooling, Heating, Auto, Dry (Dehumidification), or Fan.

Note:

Each function will display on the LED for about three (3) seconds when the power is first cycled on.

AKB72955816¹ Wired Controller.

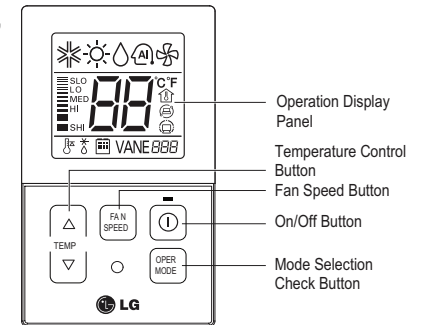

¹Simple Mode Controllers for the vertical-horizontal air handling indoor units are also referenced by Model No. PQRCVCLQW.

Wired Controller Connections

Controllers can connect to the indoor unit in one of two different ways.

1. LG Wired Remote Extension Cable with Molex plug (PZCWRC1; sold separately) that connects to the CN-REMO terminal on the indoor unit PCB.
2. Field-supplied controller cable that connects to the indoor unit terminal block (must be at least UL2547 or UL1007, 22 AWG, two-core, one-shield core, at least FT-6 rated if local electric and building codes require plenum cable usage).

Figure 213:PZCWRC1 LG Wired Remote Extension Cable.

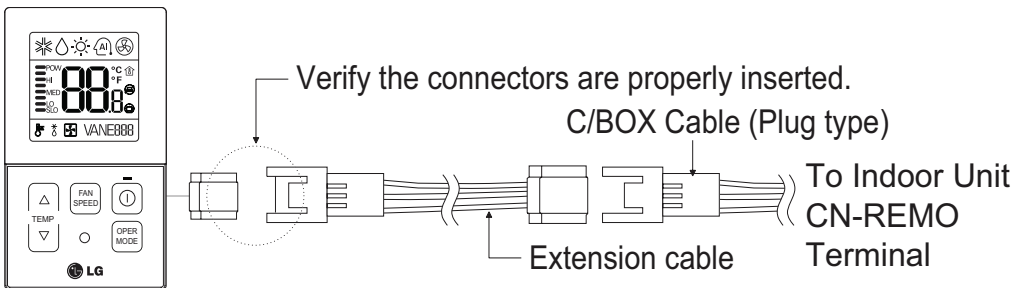
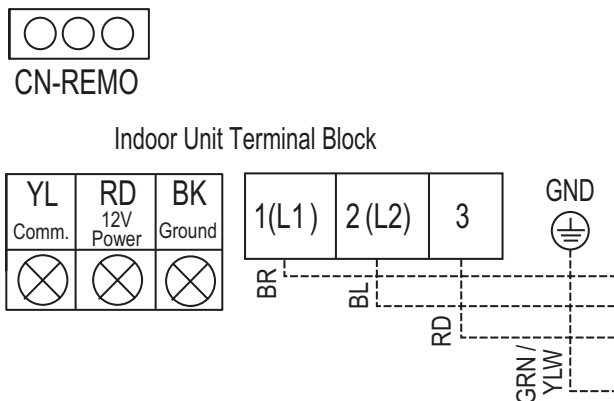

Figure 214:Wired Controller Connection on the Indoor Unit Terminal Block.



Note:

When using field-supplied controller cable, make sure to connect the yellow to yellow (communications wire), red to red (12V power wire), and black to black (ground wire) terminals from the remote controller to the indoor unit terminal blocks.

TWO-WAY VAHU INDOOR UNITS

Installation and Best Layout Practices

MULTI F
MULTI F MAX

Wired Controller Placement

Wired controllers include a sensor to detect room temperature. To maintain comfort levels in the conditioned space, the wired controller must be installed in a location away from direct sunlight, high humidity, and where it could be directly exposed to cold air. Controller must be installed four (4) to five (5) feet above the floor where its LED display can be read easily, in an area with good air circulation, and where it can detect an average room temperature.

⊘ Do not install the wired controller near or in:

- Drafts or dead spots behind doors and in corners
- Hot or cold air from ducts
- Radiant heat from the sun or appliances
- Concealed pipes and chimneys
- An area where temperatures are uncontrolled, such as an outside wall

Hanging the Wired Controller

1. The controller wiring / cable can be installed in one of three directions: top, back, or on the right side. If top or right side installation is desired, remove cable guide grooves on the controller, and then position wiring / cable on applicable side.
2. Choose and mark the area of installation, and then screw the wall plate into place (using the provided parts). Install the controller wall plate to fit the electrical box if one is present. Ensure that no gaps exist between the wall plate and the wall itself.
3. Arrange wiring / cables so as not to interfere with the controller circuitry. Position the wired controller on the wall plate. Snap into place by pressing the bottom part of the wired controller onto the wall plate. Make sure that no gaps exist between the wired controller and the wall plate on all sides.
4. To remove wired controller from the wall plate, insert a screwdriver into the two holes at the bottom. Twist screwdriver to release controller. ⊘ Do not damage the controller components when removing.

Figure 215: Proper Location for the Wired Controller.

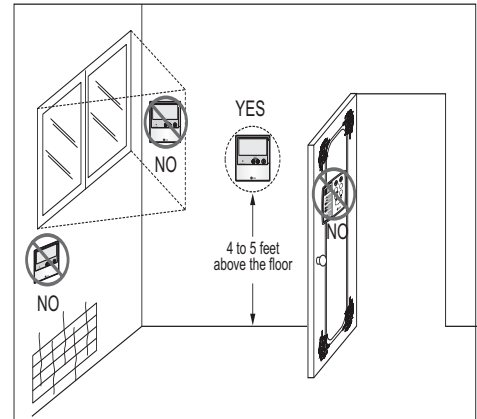

Figure 216: Removing the Cable Guide Grooves.

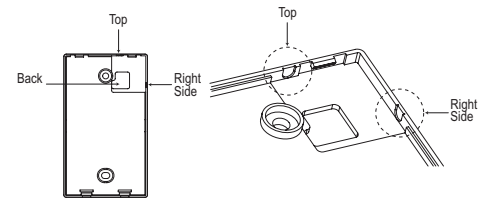

Figure 217: Attaching the Wall Plate.

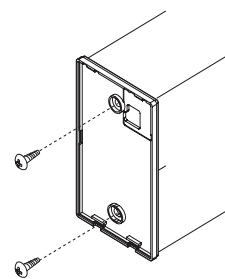
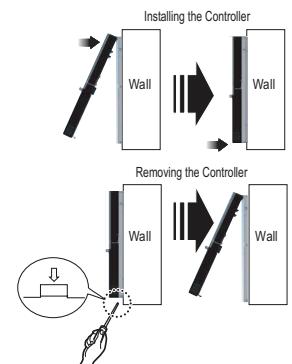

Figure 218: Installing / Removing the Controller.



Assigning the Thermistor for Temperature Detection

Each indoor unit includes a return air thermistor assigned to sense the temperature. If a wired controller is installed, there is a choice of sensing temperature with either the indoor unit return air thermistor or the thermistor in the wired controller. It is also an option to set both thermistors to sense temperature so that indoor unit bases its operation on the first thermistor to reach the designated temperature differential. For applicable indoor units, an optional Remote Temperature Sensor can be used in lieu of the return air thermistor—either alone or in conjunction with a wired controller thermistor as previously described.

MULTI F
MULTI F MAX

FOUR-WAY VERTICAL-HORIZONTAL AIR HANDLING INDOOR UNIT DATA

“Mechanical Specifications” on page 157

“General Data / Specifications” on page 157

“Dimensions” on page 158

“Cooling Capacity Table” on page 160

“Heating Capacity Table” on page 162

“External Static Pressure” on page 164

“Acoustic Data” on page 167

“Refrigerant Flow Diagram” on page 170

“Wiring Diagram” on page 171

“Factory Supplied Parts and Materials” on page 173

“Installation and Best Layout Practices” on page 174

Four-way Vertical-Horizontal Air Handling Indoor Unit

General

All LG indoor units are factory assembled, wired, piped, and provided with a control circuit board, fan, and motor. Vertical-Horizontal Air Handling units are designed for high-speed air volume against an external static pressure up to 1.00"WG. Supply air opening is flanged to accept field-installed ductwork that cannot exceed the external static pressure limit of the unit.

Coil

Indoor unit coils are factory built and are comprised of aluminum fins mechanically bonded to copper tubing. Each unit has a minimum of two rows of coils, which are pressure tested at the factory. Each unit is provided with a factory installed condensate drain pan below the coil.

Refrigerant System

System is designed for use with R410A refrigerant. The refrigeration circuit is pressure-tested at the factory and shipped with a holding charge of helium gas. Refrigerant pipe connections are 45° flare, and all refrigerant lines from the outdoor unit to the indoor units must be field insulated.

Electrical

Each indoor unit is designed to operate using 208–230/60/1 power with voltage variances of ±10%.

Casing

The casing is designed to mount fully concealed behind a wall or above a finished ceiling. Casing is manufactured of 22-gauge pre-coated metal and finished with a high-gloss baked enamel finish. Cold surfaces of the unit are covered internally with 1/2-inch polystyrene fiber insulation; inside surface of the pan assembly door access panel is treated with 1/2-inch polystyrene fiber insulation, encapsulated on both sides. The access panel is sealed along the edges with reinforced foil-faced covering, all access panels also have gasket seals to minimize air leaks.

The vertical-horizontal air handling unit can operate in one of four airflow configurations: vertical upflow, vertical downflow, horizontal left discharge, or horizontal right discharge. Vertical downflow operation requires an optional conversion kit. In the vertical position, the unit has an opening for supply air from top (or bottom) with a dedicated bottom (or top) vertical return. In the horizontal position, supply air is from the left (or right) end with the return air from the right (or left) end. Unit can also accept an internal, optional LG electrical strip heater.

Features

- Inverter (Variable speed fan)
- Control lock function
- Auto operation
- Dehumidifying function
- Two thermistor control
- Group control
- External static pressure control
- Self-diagnostics function
- Wired thermostat included
- Built-in dry contact for 3rd party thermostat



Figure 219: Multi F Vertical-Horizontal Air Handling Indoor Unit.



Fan Assembly and Control

The units have an integral fan assembly consisting of galvanized steel housing and a forward curve fan wheel. The fan motor is a brushless digitally controlled (BLDC) motor with permanently lubricated and sealed ball bearings. The fan / motor assembly is mounted on vibration-attenuating rubber grommets. Fan speed is controlled using a microprocessor-based direct digital control algorithm. The indoor fan has Low, Med, High, and Auto settings for Cooling mode; and has Low, Med, High, and Auto settings for Heating mode. Each of the settings can be field-adjusted from the factory setting (RPM / ESP). The Auto setting adjusts the fan speed to most effectively achieve setpoint.

Filter Assembly

The unit comes with a filter rack sized to hold a field-provided 16" x 20" x 1" (NJ frame) or 24" x 20" x 1" (NK frame) filter cartridge. The filter rack has a guide to assist in centering the filters, and can be accessed from the front.

Microprocessor Control

The indoor unit is provided with an integrated control panel to communicate with the outdoor unit. All unit operation parameters are stored in non-volatile memory resident on the unit microprocessor. The microprocessor controls space temperature through using the value provided by temperature sensors within the indoor unit. A field-supplied communication cable must be installed to connect the indoor unit(s) to the outdoor unit.

Controls

The indoor unit is supplied with an LG wired controller. Communication between the indoor units and the outdoor unit is accomplished through 18 AWG, four-core, stranded and shielded power / communication cable. The indoor unit has a built-in dry contact for a field supplied 3rd party thermostat. An optional Wi-Fi module is available as an additional accessory for use with LG's SmartThinQ app on a smart device.

Condensate

The unit is designed for gravity draining of condensate.

FOUR-WAY VAHU INDOOR UNITS

General Data / Specifications

MULTI F
MULTI F MAX

Table 91: Multi F Vertical-Horizontal Air Handling Indoor Unit General Data.

Model Name	LVN180HV4	LVN240HV4	LVN360HV4
Nominal Cooling Capacity (Btu/h) ¹	18,000	24,000	36,000
Nominal Heating Capacity (Btu/h) ¹	20,000	27,000	40,000
<i>Operating Range</i>			
Cooling (°F WB)	57-77	57-77	57-77
Heating (°F DB)	59-81	59-81	59-81
<i>Fan</i>			
Type	Sircocco	Sircocco	Sircocco
Motor Output (W) x Qty.	198 x 1	198 x 1	400 x 1
Motor/Drive	Brushless Digitally Controlled / Direct	Brushless Digitally Controlled / Direct	Brushless Digitally Controlled / Direct
Airflow Rate CFM (H/M/L) at 0.5" WG ESP	640 / 580 / 480	710 / 640 / 480	1,100 / 1,000 / 900
Maximum External Static Pressure (in. WG)	0.7	0.7	1.00
<i>Unit Data</i>			
Refrigerant Type ²	R410A	R410A	R410A
Refrigerant Control	EEV	EEV	EEV
Power Supply V, Ø, Hz ³	208-230, 1, 60	208-230, 1, 60	208-230, 1, 60
Rated Amps (A)	1.1	1.1	2.2
Sound Pressure Level ±3 dB(A) (H/M/L) ⁴ at 0.3"WG ESP	42 / 42 / 41	43 / 42 / 41	45 / 44 / 43
Dimensions (W x H x D, in.)	18 x 48-11/16 x 21-1/4	18 x 48-11/16 x 21-1/4	25 x 55-3/16 x 21-1/4
Net Weight (lbs.)	129	129	165
Shipping Weight (lbs.)	140	140	188
Power Wiring / Communications Cable (No. x AWG) ⁵	4 x 18	4 x 18	4 x 18
Heat Exchanger (Row x Column x Fin / inch) x Number	(3x 24 x 18) x 2	(3x 24 x 18) x 2	(3x 30 x 18) x 2
<i>Pipe Size</i>			
Liquid (in.)	1/4	1/4	3/8
Vapor (in.)	1/2	1/2	5/8
<i>Connection Size</i>			
Liquid (in.)	3/8	3/8	3/8
Vapor (in.)	5/8	5/8	5/8
Primary Drain I.D. (in.)	3/4 FPT	3/4 FPT	3/4 FPT
Secondary Drain I.D. (in.)	3/4 FPT	3/4 FPT	3/4 FPT

¹Nominal capacity is rated 0 ft. above sea level with corresponding refrigerant piping length in accordance with standard length of each outdoor unit and a 0 ft. level difference between outdoor and indoor units. All capacities are net with a combination ratio between 95 – 105%.

Nominal cooling capacity rating obtained with air entering the indoor unit at 80°F dry bulb (DB) and 67°F wet bulb (WB) and outdoor ambient conditions of 95°F dry bulb (DB) and 75°F wet bulb (WB).
Nominal heating capacity rating obtained with air entering the indoor unit at 70°F dry bulb (DB) and 60°F wet bulb (WB) and outdoor ambient conditions of 47°F dry bulb (DB) and 43°F wet bulb (WB).

²This unit comes with a dry helium charge.

³Acceptable operating voltage: 187V-253V.

⁴Sound pressure levels are tested in an anechoic chamber under ISO Standard 3745 and are the same in both cooling and heating mode. These values can increase due to ambient conditions during operation.

⁵All power wiring / communications cable to the IDUs must be minimum 18 AWG, 4-conductor, stranded, shielded or unshielded (if shielded, must be grounded to chassis at ODU only) and must comply with applicable local and national codes.

Figure 220: Four-way Vertical Air Handling Unit Dimensions.

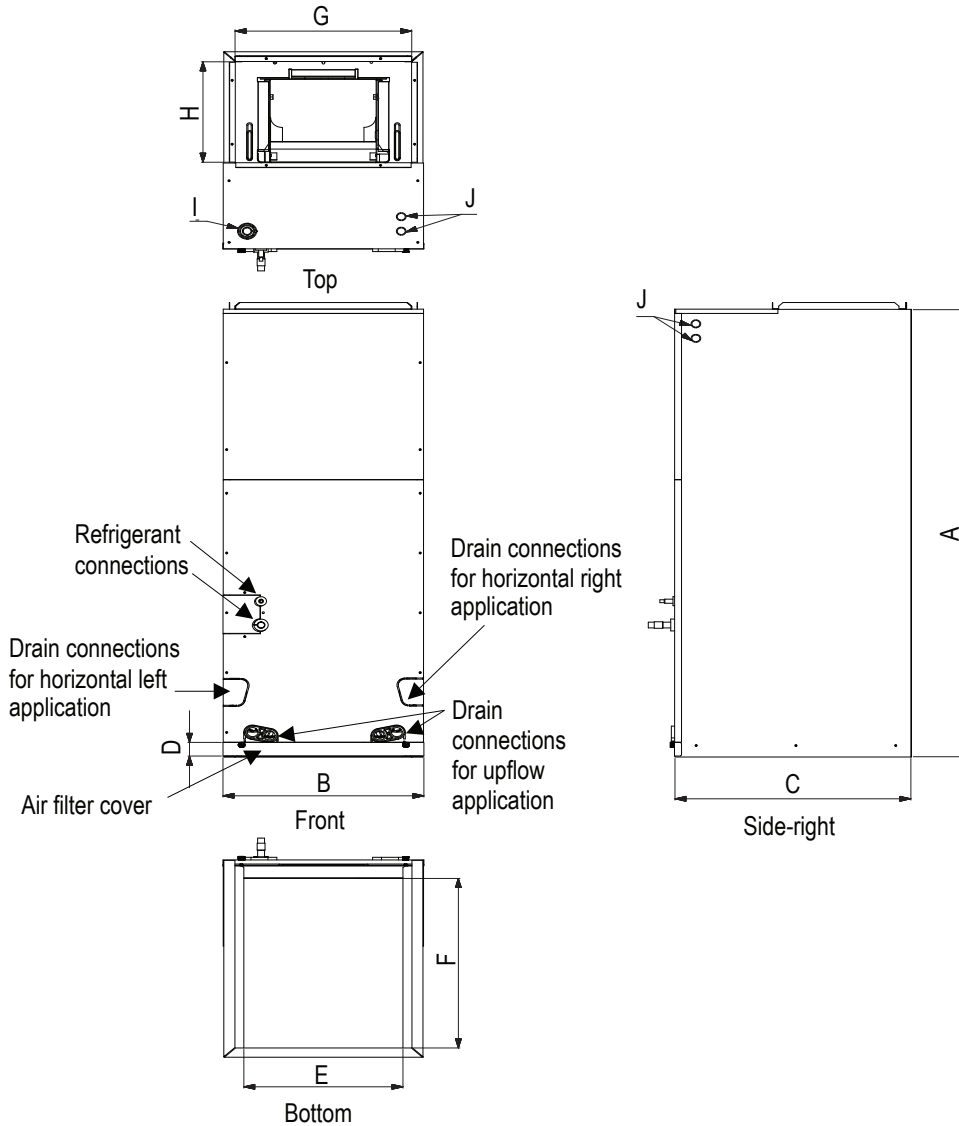

Vertical-Horizontal Air Handling Unit

Unit: inch

ODU	Capacity (kBtu/h)	Dimensions								Wiring Knock out		Refrigerant Pipe size		Refrigerant Pipe Connections	
		A	B	C	D	E	F	G	H	I	J	Liquid	Gas	Liquid	Gas
		Height	Width	Depth						Power	Comm-unication				
Multi Zone	18 24	48-5/8	18	21-3/8	1-9/16	17-1/2	20	17	12-1/8	1-11/16	7/8	1/4	1/2	3/8	5/8
	36	55-1/8	25	21-3/8	1-9/16	24-1/2	20	24	12-1/8	1-11/16	7/8	3/8	5/8	3/8	5/8

FOUR-WAY VAHU INDOOR UNITS

Cooling Capacity Table

MULTI F
MULTI F MAX

Table 92: Multi F Vertical-Horizontal Air Handling Indoor Units Cooling Capacity Table.

Model No. / Nominal Capacity of Indoor Unit (Btu/h)	Outdoor Air Temp. (°F DB)	Indoor Air Temp. °F DB / °F WB											
		68 / 57		73 / 61		77 / 64		80 / 67		86 / 72		90 / 75	
		TC	SHC	TC	SHC	TC	SHC	TC	SHC	TC	SHC	TC	SHC
LVN180HV4 18,000	14	17.65	13.25	18.74	13.99	19.84	13.55	20.63	13.83	22.03	13.95	23.12	14.22
	20	17.63	13.35	18.73	14.10	19.82	13.65	20.61	13.94	22.01	14.06	23.11	14.33
	25	17.62	13.45	18.71	14.21	19.81	13.76	20.60	14.05	22.00	14.17	23.09	14.44
	30	17.60	13.56	18.70	14.32	19.79	13.87	20.58	14.16	21.98	14.28	23.07	14.55
	35	17.59	13.66	18.68	14.43	19.78	13.97	20.57	14.27	21.96	14.39	23.05	14.66
	40	17.58	13.76	18.67	14.54	19.76	14.08	20.55	14.37	21.94	14.49	23.04	14.77
	45	17.56	13.87	18.66	14.65	19.75	14.18	20.53	14.48	21.93	14.60	23.02	14.88
	50	17.55	13.97	18.64	14.75	19.73	14.29	20.52	14.59	21.91	14.71	23.00	14.99
	55	17.54	14.07	18.63	14.86	19.72	14.39	20.50	14.69	21.89	14.82	22.98	15.10
	60	17.52	14.17	18.61	14.97	19.70	14.50	20.49	14.80	21.88	14.93	22.97	15.21
	65	17.51	14.27	18.60	15.08	19.69	14.60	20.47	14.91	21.86	15.03	22.95	15.32
	70	17.50	14.38	18.58	15.19	19.67	14.70	20.46	15.01	21.84	15.14	22.93	15.43
	75	17.08	14.14	18.16	14.96	19.24	14.50	20.03	14.81	21.41	14.96	22.50	15.25
	80	16.66	13.90	17.74	14.72	18.82	14.29	19.60	14.61	20.98	14.77	22.06	15.07
	85	16.24	13.64	17.32	14.47	18.40	14.06	19.17	14.39	20.55	14.57	21.63	14.88
	90	15.82	13.39	16.90	14.22	17.97	13.84	18.75	14.17	20.12	14.36	21.20	14.69
	95	15.37	13.25	16.44	14.09	17.51	13.73	18.00	13.86	19.65	14.29	20.72	14.62
	100	14.99	12.89	16.06	13.74	17.13	13.40	17.77	13.65	19.28	13.98	20.35	14.32
105	14.62	12.54	15.69	13.38	16.76	13.08	17.53	13.43	18.90	13.67	19.97	14.02	
110	14.24	12.11	15.32	12.95	16.39	12.67	17.16	13.03	18.53	13.29	19.60	13.64	
115	13.87	11.75	14.94	12.58	16.01	12.34	16.79	12.70	18.15	12.97	19.22	13.33	
118	13.65	11.66	14.72	12.51	15.79	12.27	16.56	12.64	17.93	12.92	19.00	13.29	
122	13.57	11.63	14.64	12.48	15.71	12.25	16.49	12.62	17.85	12.91	18.92	13.28	
LVN240HV4 24,000	14	23.53	17.89	24.99	18.90	26.45	18.30	27.50	18.69	29.37	18.84	30.83	19.20
	20	23.51	18.03	24.97	19.05	26.43	18.44	27.48	18.83	29.35	18.99	30.81	19.35
	25	23.49	18.17	24.95	19.20	26.41	18.59	27.46	18.98	29.33	19.14	30.79	19.50
	30	23.47	18.31	24.93	19.34	26.39	18.73	27.44	19.12	29.30	19.28	30.76	19.65
	35	23.46	18.45	24.91	19.49	26.37	18.87	27.42	19.27	29.28	19.43	30.74	19.80
	40	23.44	18.59	24.89	19.64	26.35	19.01	27.40	19.41	29.26	19.58	30.72	19.95
	45	23.42	18.73	24.87	19.78	26.33	19.15	27.38	19.56	29.24	19.72	30.69	20.10
	50	23.40	18.87	24.85	19.93	26.31	19.30	27.36	19.70	29.21	19.87	30.67	20.24
	55	23.38	19.00	24.84	20.07	26.29	19.44	27.34	19.85	29.19	20.01	30.64	20.39
	60	23.37	19.14	24.82	20.22	26.27	19.58	27.32	19.99	29.17	20.16	30.62	20.54
	65	23.35	19.28	24.80	20.37	26.25	19.72	27.29	20.13	29.15	20.30	30.60	20.69
	70	23.33	19.42	24.78	20.51	26.23	19.86	27.27	20.28	29.13	20.45	30.57	20.84
	75	22.77	19.10	24.21	20.20	25.66	19.58	26.70	20.01	28.55	20.20	29.99	20.60
	80	22.21	18.77	23.65	19.88	25.09	19.30	26.13	19.73	27.97	19.95	29.42	20.36
	85	21.65	18.43	23.09	19.55	24.53	18.99	25.57	19.44	27.40	19.68	28.84	20.10
	90	21.09	18.08	22.53	19.21	23.96	18.69	25.00	19.14	26.83	19.40	28.27	19.84
	95	20.49	17.89	21.92	19.03	23.35	18.55	24.00	18.72	26.20	19.30	27.63	19.75
	100	19.99	17.41	21.42	18.55	22.85	18.10	23.69	18.43	25.70	18.88	27.13	19.35
105	19.49	16.93	20.92	18.07	22.35	17.66	23.38	18.14	25.20	18.47	26.63	18.94	
110	18.99	16.35	20.42	17.49	21.85	17.12	22.88	17.60	24.70	17.94	26.13	18.42	
115	18.49	15.86	19.92	17.00	21.35	16.66	22.38	17.15	24.20	17.51	25.63	18.00	
118	18.19	15.75	19.62	16.89	21.05	16.58	22.08	17.07	23.90	17.46	25.33	17.96	
122	18.10	15.71	19.52	16.86	20.95	16.55	21.98	17.05	23.81	17.44	25.23	17.94	

TC = Total Capacity (kBtu/h).

SHC: Sensible Heat Capacity (kBtu/h).

Nominal capacity as rated 0 ft. above sea level and a 0 ft. level difference between outdoor and indoor units. Corresponding refrigerant piping length is accordance with standard length of each outdoor unit.

Nominal cooling capacity rating obtained with air entering the indoor unit at 80°F dry bulb (DB) and 67°F wet bulb (WB), and outdoor ambient conditions of 95°F dry bulb (DB) and 75°F wet bulb (WB).

The shaded table columns and rows indicate reference data. When operating at this temperature, these values can be different if the system is not running consistently.

Multi F and Multi F MAX Indoor Unit Engineering Manual

Table 91: Multi F Vertical-Horizontal Air Handling Indoor Units Cooling Capacity Table - continued

Model No. / Nominal Capacity of Indoor Unit (Btu/h)	Outdoor Air Temp. (°F DB)	Indoor Air Temp. °F DB / °F WB											
		68 / 57		73 / 61		77 / 64		80 / 67		86 / 72		90 / 75	
		TC	SHC	TC	SHC	TC	SHC	TC	SHC	TC	SHC	TC	SHC
LVN360HV4 18,000	14	35.29	27.18	37.48	28.71	39.67	27.80	41.26	28.39	44.06	28.63	46.25	29.17
	20	35.26	27.39	37.45	28.94	39.64	28.02	41.23	28.61	44.02	28.85	46.21	29.40
	25	35.24	27.61	37.43	29.16	39.61	28.24	41.19	28.83	43.99	29.07	46.18	29.62
	30	35.21	27.82	37.40	29.39	39.58	28.45	41.16	29.05	43.96	29.30	46.14	29.85
	35	35.18	28.03	37.37	29.61	39.55	28.67	41.13	29.27	43.92	29.52	46.11	30.08
	40	35.16	28.24	37.34	29.83	39.52	28.88	41.10	29.49	43.89	29.74	46.07	30.30
	45	35.13	28.45	37.31	30.05	39.49	29.10	41.07	29.71	43.86	29.96	46.04	30.53
	50	35.10	28.66	37.28	30.28	39.46	29.32	41.04	29.93	43.82	30.19	46.00	30.76
	55	35.08	28.87	37.25	30.50	39.43	29.53	41.01	30.15	43.79	30.41	45.97	30.98
	60	35.05	29.08	37.23	30.72	39.40	29.74	40.97	30.37	43.76	30.63	45.93	31.21
	65	35.02	29.29	37.20	30.94	39.37	29.96	40.94	30.59	43.72	30.85	45.90	31.43
	70	34.99	29.50	37.17	31.16	39.34	30.17	40.91	30.81	43.69	31.07	45.86	31.66
	75	34.15	29.01	36.32	30.69	38.49	29.75	40.05	30.40	42.82	30.69	44.99	31.30
	80	33.31	28.52	35.47	30.20	37.64	29.31	39.20	29.98	41.96	30.30	44.12	30.93
	85	32.48	28.00	34.63	29.70	36.79	28.86	38.35	29.53	41.10	29.89	43.26	30.54
	90	31.64	27.47	33.79	29.18	35.94	28.39	37.50	29.08	40.25	29.48	42.40	30.14
	95	30.74	27.18	32.88	28.92	35.02	28.17	36.00	28.44	39.30	29.32	41.44	30.01
	100	29.99	26.45	32.13	28.19	34.27	27.50	35.53	28.00	38.55	28.69	40.69	29.39
105	29.24	25.72	31.38	27.46	33.52	26.83	35.07	27.56	37.80	28.06	39.94	28.78	
110	28.49	24.84	30.63	26.57	32.77	26.00	34.32	26.74	37.05	27.26	39.20	27.99	
115	27.74	24.10	29.88	25.82	32.02	25.31	33.57	26.05	36.31	26.61	38.45	27.35	
118	27.29	23.93	29.43	25.66	31.57	25.19	33.12	25.94	35.86	26.52	38.00	27.28	
122	27.14	23.87	29.28	25.61	31.43	25.14	32.97	25.90	35.71	26.49	37.85	27.25	

TC = Total Capacity (kBtu/h).

SHC: Sensible Heat Capacity (kBtu/h).

Nominal capacity as rated 0 ft. above sea level and a 0 ft. level difference between outdoor and indoor units. Corresponding refrigerant piping length is accordance with standard length of each outdoor unit.

Nominal cooling capacity rating obtained with air entering the indoor unit at 80°F dry bulb (DB) and 67°F wet bulb (WB), and outdoor ambient conditions of 95°F dry bulb (DB) and 75°F wet bulb (WB).

The shaded table columns and rows indicate reference data. When operating at this temperature, these values can be different if the system is not running consistently.

FOUR-WAY VAHU INDOOR UNITS

Heating Capacity Table

MULTI F
MULTI F MAX

Table 93: Multi F Vertical-Horizontal Air Handling Indoor Units Heating Capacity Table.

Model No. / Nominal Capacity of Indoor Unit (Btu/h)	Outdoor Air Temp.		Indoor Air Temp. °F DB					
	°F DB	°F WB	61	64	68	70	72	75
			TC	TC	TC	TC	TC	TC
LVN180HV4 18,000	0	-0.4	10.29	10.14	10.05	10.00	9.86	9.42
	5	4.5	11.59	11.45	11.35	11.30	11.16	10.72
	10	9	12.90	12.75	12.66	12.61	12.46	12.03
	17	15	14.64	14.49	14.40	14.35	14.20	13.74
	20	19	15.29	15.14	15.05	15.00	14.86	14.35
	25	23	16.38	16.23	16.14	16.09	15.94	15.36
	30	28	17.32	17.17	17.08	17.03	16.88	16.38
	35	32	18.26	18.12	18.02	17.97	17.83	17.39
	40	36	19.11	18.96	18.86	18.82	18.67	18.24
	45	41	19.95	19.81	19.71	19.66	19.52	19.08
	47	43	20.29	20.14	20.05	20.00	19.86	19.42
	50	46	20.62	20.47	20.37	20.33	20.18	19.69
	55	51	21.16	21.01	20.92	20.87	20.72	20.14
	60	56	21.16	21.01	20.92	20.87	20.72	20.24
	63	59	21.16	21.01	20.92	20.87	20.72	20.29
68	64	21.16	21.01	20.92	20.87	20.72	20.38	
LVN240HV4 24,000	0	-0.4	13.89	13.70	13.57	13.50	13.30	12.72
	5	4.5	15.65	15.46	15.33	15.26	15.07	14.48
	10	9	17.41	17.22	17.09	17.02	16.83	16.24
	17	15	19.76	19.57	19.43	19.37	19.17	18.55
	20	19	20.64	20.45	20.32	20.25	20.05	19.37
	25	23	22.11	21.91	21.78	21.72	21.52	20.74
	30	28	23.38	23.18	23.05	22.99	22.79	22.11
	35	32	24.65	24.46	24.33	24.26	24.07	23.48
	40	36	25.79	25.60	25.47	25.40	25.21	24.62
	45	41	26.93	26.74	26.61	26.54	26.35	25.76
	47	43	27.39	27.20	27.07	27.00	26.80	26.22
	50	46	27.83	27.64	27.51	27.44	27.24	26.58
	55	51	28.57	28.37	28.24	28.17	27.98	27.20
	60	56	28.57	28.37	28.24	28.17	27.98	27.32
	63	59	28.57	28.37	28.24	28.17	27.98	27.39
68	64	28.57	28.37	28.24	28.17	27.98	27.51	

TC = Total Capacity (kBtu/h).

Nominal capacity as rated 0 ft. above sea level and a 0 ft. level difference between outdoor and indoor units. Corresponding refrigerant piping length is accordance with standard length of each outdoor unit. Nominal heating capacity rating obtained with air entering the indoor unit at 70°F dry bulb (DB) and 60°F wet bulb (WB), and outdoor ambient conditions of 47°F dry bulb (DB) and 43°F wet bulb (WB).

Multi F and Multi F MAX Indoor Unit Engineering Manual

Table 92: Multi F Vertical-Horizontal Air Handling Indoor Units Heating Capacity Table - continued

Model No. / Nominal Capacity of Indoor Unit (Btu/h)	Outdoor Air Temp.		Indoor Air Temp. °F DB					
	°F DB	°F WB	61	64	68	70	72	75
			TC	TC	TC	TC	TC	TC
LVN360HV4 36,000	0	-0.4	20.58	20.29	20.10	20.00	19.71	18.84
	5	4.5	23.19	22.90	22.71	22.61	22.32	21.45
	10	9	25.80	25.51	25.31	25.22	24.93	24.06
	17	15	29.28	28.99	28.79	28.70	28.41	27.48
	20	19	30.58	30.29	30.10	30.00	29.71	28.70
	25	23	32.75	32.46	32.27	32.17	31.88	30.72
	30	28	34.64	34.35	34.15	34.06	33.77	32.75
	35	32	36.52	36.23	36.04	35.94	35.65	34.78
	40	36	38.21	37.92	37.73	37.63	37.34	36.47
	45	41	39.90	39.61	39.42	39.32	39.03	38.16
	47	43	40.58	40.29	40.10	40.00	39.71	38.84
	50	46	41.23	40.94	40.75	40.65	40.36	39.38
	55	51	42.32	42.03	41.84	41.74	41.45	40.29
	60	56	42.32	42.03	41.84	41.74	41.45	40.47
	63	59	42.32	42.03	41.84	41.74	41.45	40.58
68	64	42.32	42.03	41.84	41.74	41.45	40.76	

TC = Total Capacity (kBtu/h).

Nominal capacity as rated 0 ft. above sea level and a 0 ft. level difference between outdoor and indoor units. Corresponding refrigerant piping length is accordance with standard length of each outdoor unit. Nominal heating capacity rating obtained with air entering the indoor unit at 70°F dry bulb (DB) and 60°F wet bulb (WB), and outdoor ambient conditions of 47°F dry bulb (DB) and 43°F wet bulb (WB).

Vertical-Horizontal Air Handling Unit

FOUR-WAY VAHU INDOOR UNITS

External Static Pressure and Airflow Ranges

MULTI F
MULTI F MAX

Figure 221: ESP Setting Values – NJ Chassis, LVN180HV4, LVN240HV4

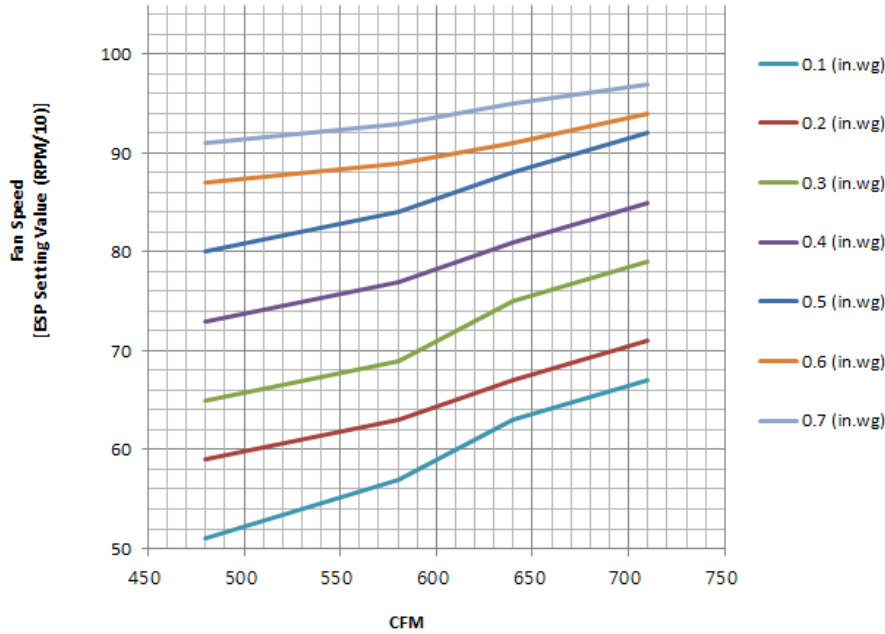

Figure 222: ESP Setting Values – NK Chassis, LVN360HV4.

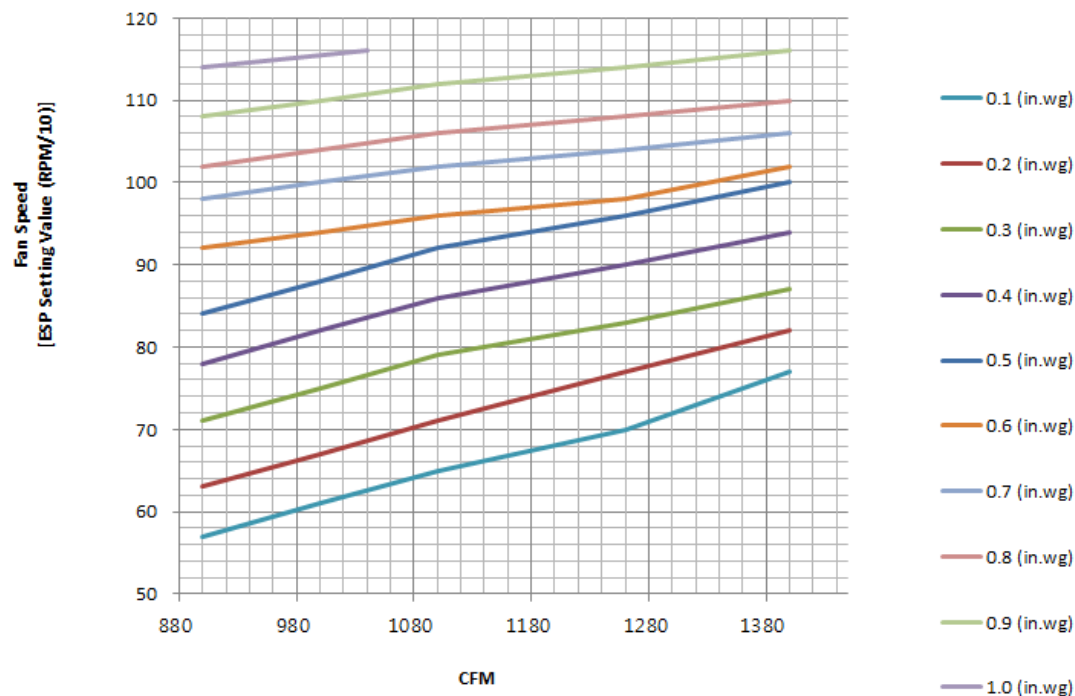

Table 94: Multi F Vertical-Horizontal Air Handling Unit External Static Pressure Setting Values Table.

Static Pressure (in. wg)			0.1	0.2	0.3	0.4	0.5	0.6	0.7	0.8	0.9	1.0
Model No. / Nominal Capacity of Indoor Unit (Btu/h)	Airflow Rate / CFM		Setting Value at (in. wg) ¹									
	LVN180HV4 18,000	High	640	63	67	75	81	88	91	95	—	—
Mid		580	57	63	69	77	84	89	93	—	—	—
Low		480	51	59	65	73	80	87	91	—	—	—
LVN240HV4 24,000	High	710	67	71	79	85	92	94	97	—	—	—
	Mid	640	63	67	75	81	88	91	95	—	—	—
	Low	480	51	59	65	73	80	87	91	—	—	—
LVN360HV4 36,000	High	1,100	65	71	79	86	92	96	102	106	112	—
	Mid	1,000	61	67	75	82	88	94	100	104	110	116
	Low	900	57	63	71	78	84	92	98	102	108	114

¹Unless otherwise noted, vertical-horizontal air handling units are UL listed up to 0.5 in. wg total static pressure, including coil, case, duct work pressure drop, air filter, and largest kW size heater. Internal static pressure includes coil and case only.

²Airflow rate (CFM) decreases by 3% per 0.1 in. wg.

³Factory default setting is 0.3 in wg

⁴Factory default setting is high static pressure

Note:

- If the ESP is set incorrectly, the air conditioning may malfunction.
- To get the desired air flow and external static pressure combination, use the setting value from the table. Using a setting value other than the values listed in the table will not provide the desired combination.

Table 95: Air Filter Static Pressure Drop Factors.

Capacity (kBtu/h [tons])	Flow Rate (CFM)	Static Pressure Drop (in wg)
18 (1.5)	High (640)	-0.04
	Middle(580)	-0.04
	Low (480)	-0.04
24 (2.0)	High (710)	-0.04
	Middle(640)	-0.04
	Low (480)	-0.04
36 (3.0)	High (1100)	-0.08
	Middle(1000)	-0.08
	Low (900)	-0.08

Table 96: Minimum Airflow (CFM) by Heater Capacity

Capacity (kBtu/h [tons])	Heater Capacity kW			
	3, 5	8, 10	15	20
18 (1.5)	480	480	Not Available	Not Available
24 (2.0)	480	480	Not Available	Not Available
36 (3.0)	900	900	900	900

⚠ WARNING

⊘ Do not operate with less than the minimum airflow. If an airflow is used below the minimum, there is a risk of fire, which may lead to physical injury or death

Note:

⊘ Do not operate with less than the minimum airflow. If an airflow is used below the minimum, there is a risk of damage to the product.

FOUR-WAY VAHU INDOOR UNITS

External Static Pressure

MULTI F
MULTI F MAX

Table 97: Electric Heater Static Pressure Drop Factors.

Heater Capacity	Static Pressure Drop (in. wg)
0	0
3, 5	-0.01
8, 10	-0.02
15	-0.03
20	-0.04

If the electric heater optional accessory is installed, adjust ESP value according to heater size
 For every increase in static pressure by 0.01 in wg, the ESP value must be increased by 1
 If the ESP setting value is inappropriate, the provided safety device will turn the heater off according to the airflow

Table 98: Down Flow (optional) Static Pressure Drop Factors.

Capacity (kBtu/h [tons])	Flow Rate (CFM)	Static Pressure Drop (in wg)
18 (1.5)	High (640)	-0.04
	Middle(580)	-0.04
	Low (480)	-0.04
24 (2.0)	High (710)	-0.04
	Middle(640)	-0.04
	Low (480)	-0.04
36 (3.0)	High (1100)	-0.09
	Middle(1000)	-0.09
	Low (900)	-0.09

If the optional down flow kit is installed, adjust ESP value as necessary
 For every increase in static pressure by 0.01 in wg, the ESP value must be increased by 1

Table 99: Down Flow Air Filter Static Pressure Drop Factors

Capacity (kBtu/h [tons])	Flow Rate (CFM)	Static Pressure Drop (in wg)
18 (1.5)	High (640)	-0.04
	Middle(580)	-0.04
	Low (480)	-0.04
24 (2.0)	High (710)	-0.04
	Middle(640)	-0.04
	Low (480)	-0.04
36 (3.0)	High (1100)	-0.06
	Middle(1000)	-0.06
	Low (900)	-0.06

If the air filter is installed, adjust ESP value as necessary
 For every increase in static pressure by 0.01 in wg, the ESP value must be increased by 1

Table 100: Down Flow Internal Electric Heater Static Pressure Drop.

Heater Capacity (kW)	Static Pressure Drop (in. wg)
0	0
3, 5	-0.01
8, 10	-0.01
15	-0.01
20	-0.01

If the electric heater optional accessory is installed, adjust ESP value according to heater size
 For every increase in static pressure by 0.01 in wg, the ESP value must be increased by 1
 If the ESP setting value is inappropriate, the provided safety device will turn the heater off according to the airflow

Table 101: Optional Electric Heater Capacities.

Heater Capacity (kW)	Static Pressure Drop (in. wg)
3	ANEH033B1
5	ANEH053B1
8	ANEH083B2
10	ANEH103B2
15	ANEH153B2
20	ANEH203B2

Figure 223: Typical Vertical Air Handling Unit Optional Electric Heater Accessory.

Example: 5kW Capacity Heater

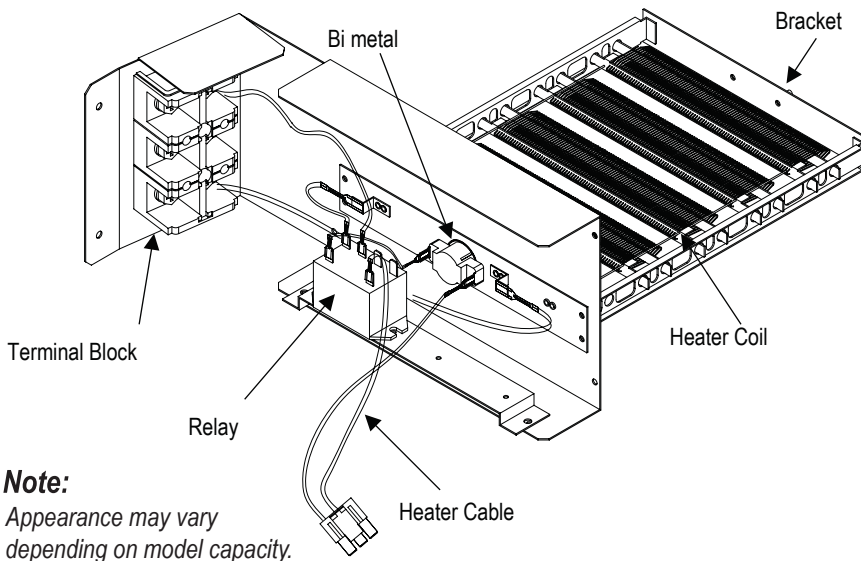

Table 102: Electric Heater Compatibility

VAHU Model Number and Capacity (MBh)	Model Number / Heater Capacity kW					
	ANEH033B1 (3kW)	ANEH053B1 (5kW)	ANEH083B2 (8kW)	ANEH103B2 (10kW)	ANEH153B2 (15kW)	ANEH203B2 (20kW)
LVN180HV4 (18)	√	√	√	√	X	X
LVN240HV4 (24)	√	√	√	√	X	X
LVN360HV4 (36)	√	√	√	√	√	√

√ = Compatible X = Not Compatible

FOUR-WAY VAHU INDOOR UNITS

Acoustic Data

MULTI F
MULTI F MAX

Figure 224: Sound Pressure Level Measurement Location.

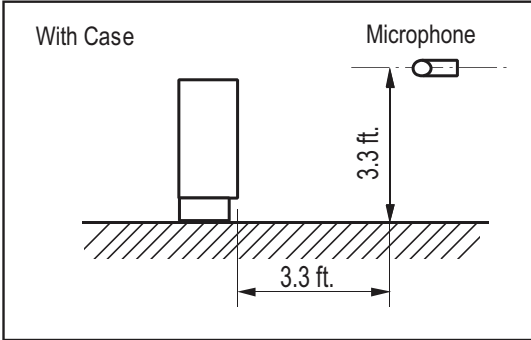

- Measurement taken 3.3' away from the unit.
- Sound pressure levels are measured in dB(A) with a tolerance of ± 3 .
- Sound pressure levels are tested in an anechoic chamber under ISO Standard 3745.
- Operating Conditions:
Power source: 220V/60 Hz.
- Sound level will vary depending on a range of factors including the construction (acoustic absorption coefficient) of a particular room in which the unit was installed.

Table 103: Vertical Air Handling Unit Sound Pressure Levels (dB[A]).

Model No.	Sound Pressure Levels (dB[A]) (Cooling and Heating)		
	High Fan Speed	Medium Fan Speed	Low Fan Speed
LVN180HV4	42	42	41
LVN240HV4	43	42	41
LVN360HV4	45	44	43

Figure 225: Sound Pressure Level Diagrams.

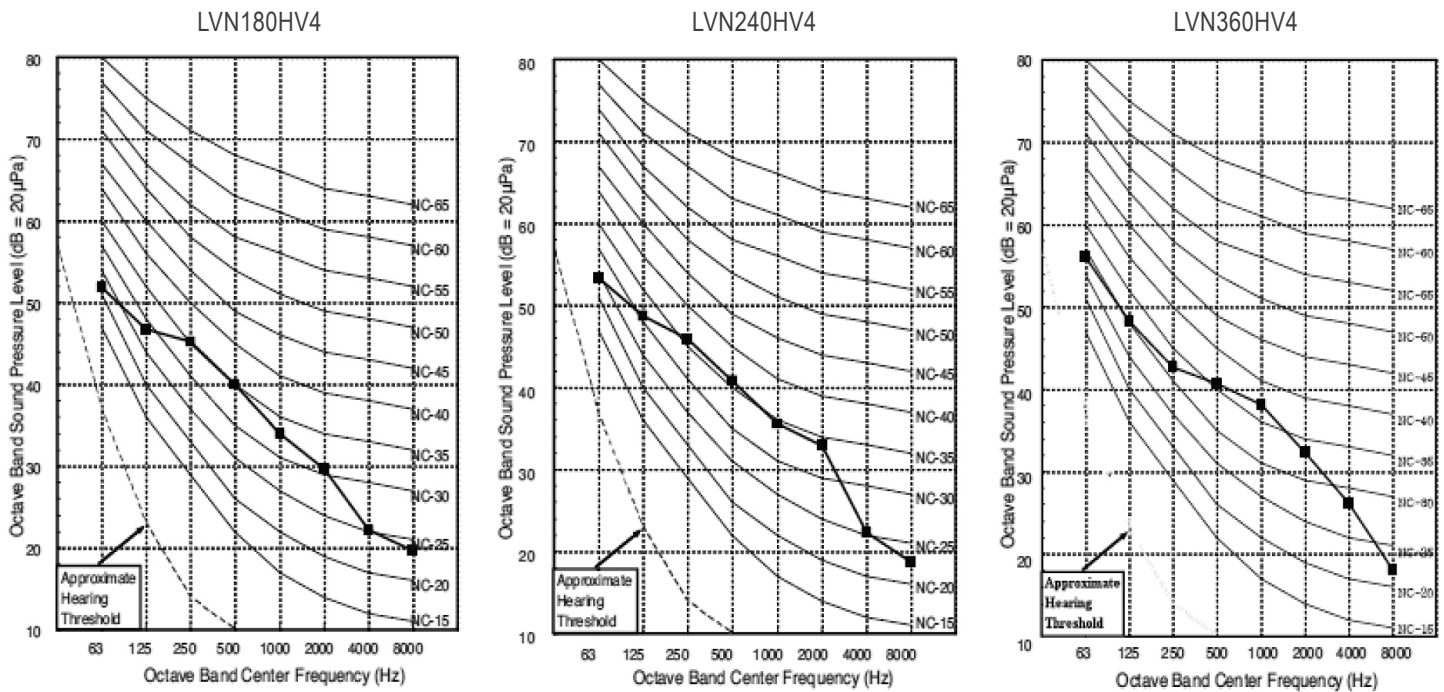
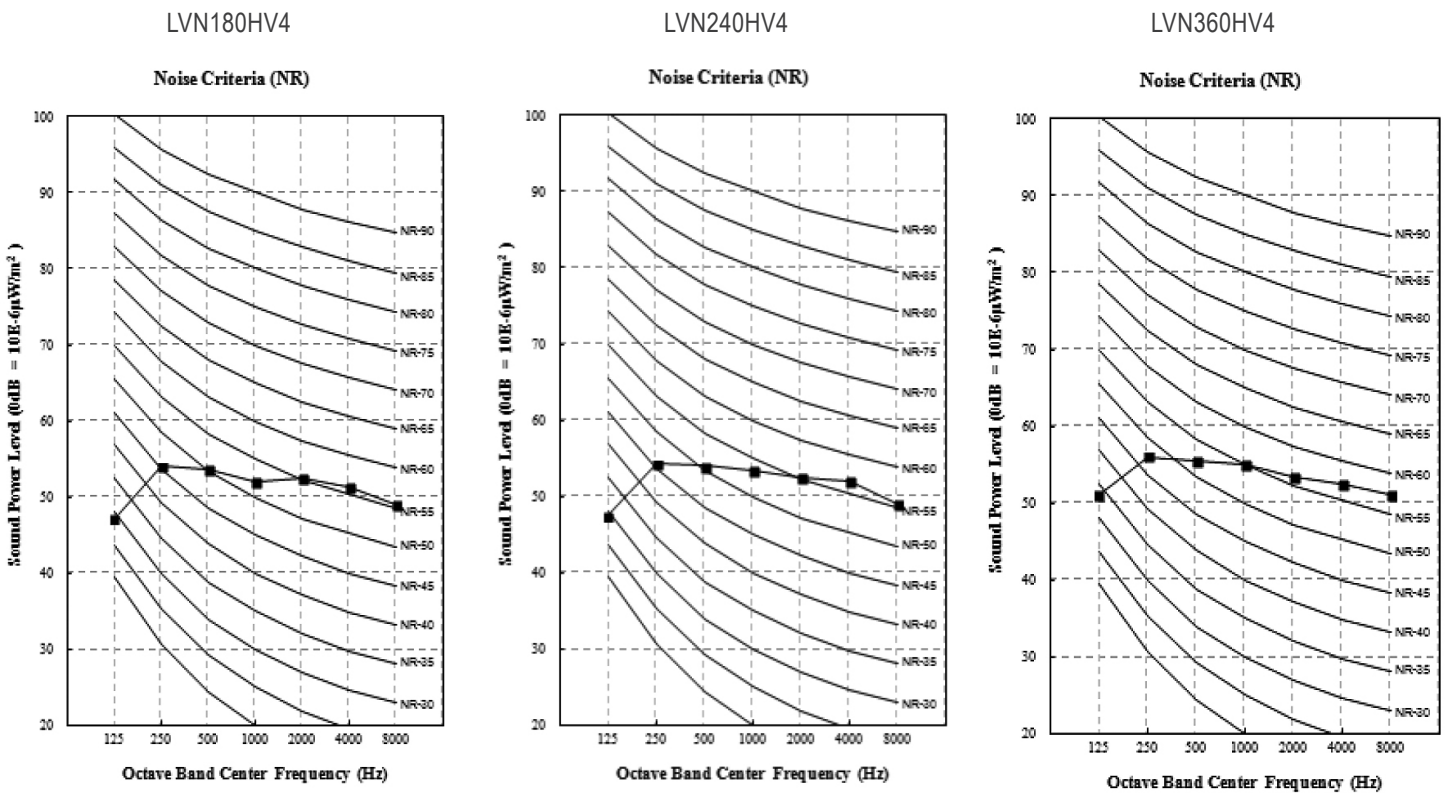

Table 104: Vertical Air Handling Unit Sound Power Levels (dB[A]).

Model No.	Sound Power Levels (dB[A])
	High Fan Speed
LVN180HV4	59
LVN240HV4	60
LVN360HV4	61

- Data is valid under diffuse field conditions.
- Data is valid under nominal operating conditions.
- Sound power level is measured using rated conditions, and tested in a reverberation room per ISO 3741 standards.
- Sound level will vary depending on a range of factors such as construction (acoustic absorption coefficient) of particular area in which the equipment is installed.
- Reference acoustic intensity: 0dB = 10E-6μW/m²

Figure 226: Sound Power Level Diagrams.



Vertical-Horizontal Air Handling Unit

FOUR-WAY VAHU INDOOR UNITS

Refrigerant Flow Diagram

MULTI F
MULTI F MAX

Figure 227: Four-way Vertical-Horizontal Air Handling Indoor Unit Refrigerant Flow Diagram.

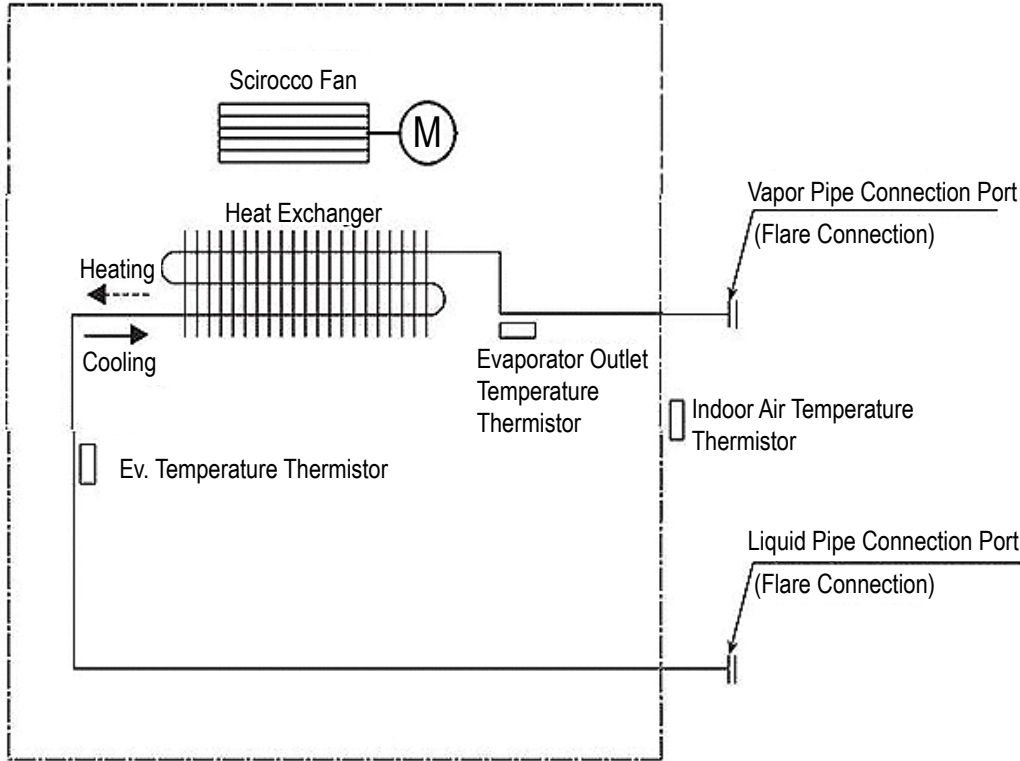

Table 105: Four-way Vertical-Horizontal Air Handling Indoor Unit Refrigerant Pipe Sizes and Connection Sizes.

Model No.	Piping Size		Connection Port Size	
	Liquid (inch)	Vapor (inch)	Liquid (inch)	Vapor (inch)
LVN180HV4	1/4	1/2	3/8	5/8
LVN240HV4	1/4	1/2	3/8	5/8
LVN360HV4	3/8	5/8	3/8	5/8

Table 106: Four-way Vertical-Horizontal Air-Handling Indoor Unit Thermistor Details.

Description (Based on Cooling Mode)	PCB Connector
Indoor Air Temperature Thermistor	CN-ROOM
Evaporator Inlet Temperature Thermistor	CN-PIPE/IN
Evaporator Outlet Temperature Thermistor	CN-PIPE/OUT

Figure 228: Four-way Vertical-Horizontal Air-Handling Indoor Unit Wiring Diagram.

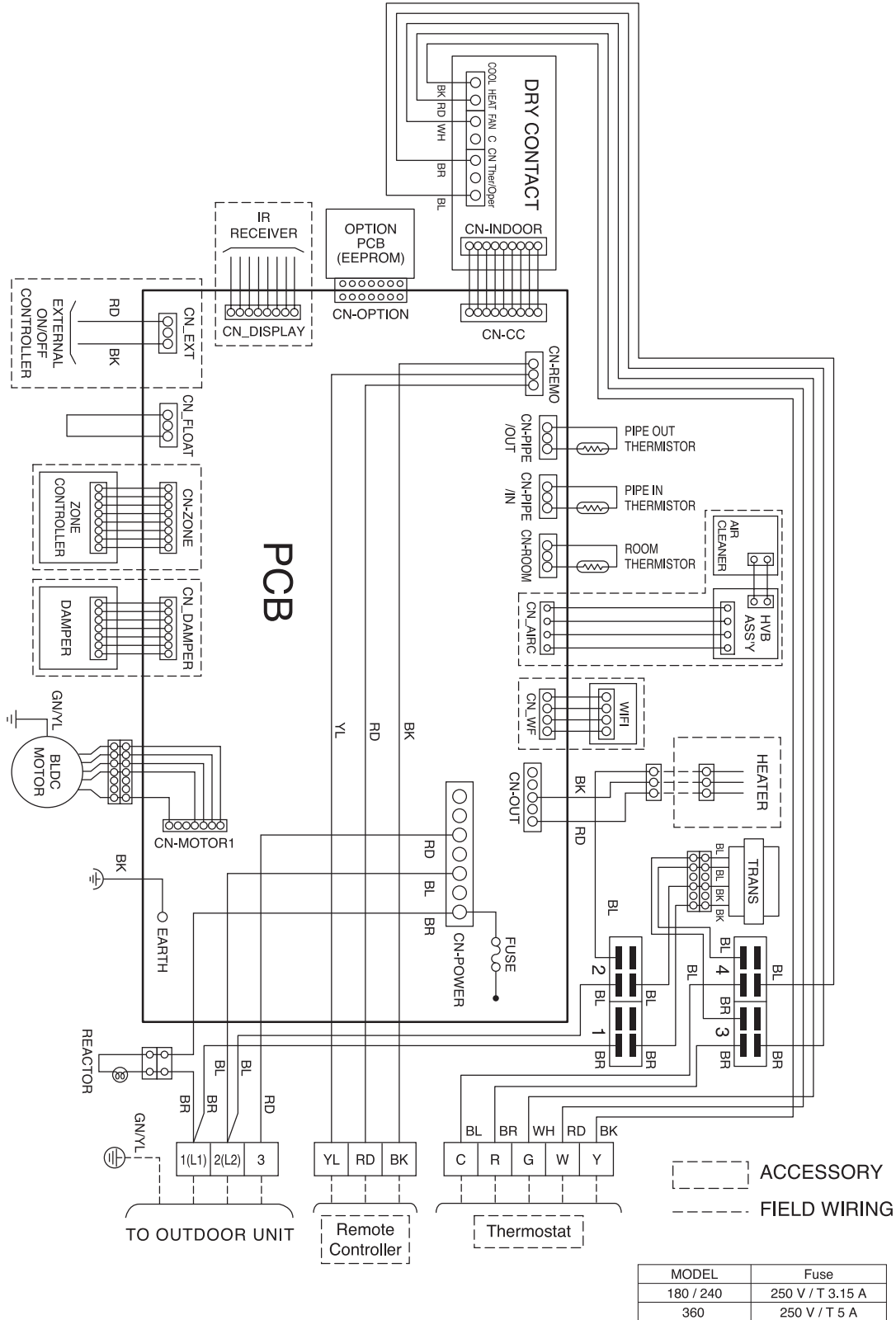

FOUR-WAY VAHU INDOOR UNITS

Wiring Diagram

MULTI F
MULTI F MAX

Table 107: Wiring Diagram Connections.

Connection Name	Location	Function
CN-POWER	AC power supply	AC Power line
CN-MOTOR1	Fan motor output	Motor output of BLDC
CN_OUT	Heater	Connection for heater
CN-D/PUMP	Drain pump output	AC output for drain pump
CN-FLOAT	Float switch input	Float switch sensing
CN-ZONE	Zone controller	Zone controller connection
CN-OPTION	Optional PCB EPROM	Option PCB connection
CN-EXT	External ON / OFF controller	External ON / OFF controller connection
CN-DISPLAY	Display	Display of indoor status
CN-CC	Dry contact	Dry Contact connection
CN-PIPE/OUT (RD)	Discharge pipe sensor	Pipe out thermistor
CN-LEAK (VI)	Refrigerant leak detector	Refrigerant leak detector connection
CN-PIPE/IN (WH)	Suction pipe sensor	Pipe in thermistor
CN-REMO (GN)	Wired remote controller	Wired remote control connection
CN-ROOM (YL)	Room sensor	Room air thermistor
CN-DAMPER	Damper Controller	Damper connection
CN-AIRC	Air Cleaner	Air Cleaner connection
CN-WF	Wifi	Wifi Module connection

Table 108: DIP Switch Settings.

Dip Switch Settings		OFF	ON	Description
SW1	Communication	Off (default)	—	—
SW2	CYCLE	Off (default)	—	—
SW3	GROUP	Master	Slave	Group control setting using wired remote controller.
SW4	DRY CONTACT	Variable	Auto	Dry contact mode setting. 1. Variable: Auto/manual mode can be chosen using the wide wired remote controller or wireless remote controller (factory setting is the manual mode). 2. Auto: For dry contact, it is always auto mode.
SW5	EXTRA1	Off	On	• ON: Fan operates continuously. • OFF: Default (Fan does not operate continuously).
SW6	HEATER	Off	On	• ON: Automatic heater operation. • OFF: Default (manual heater operation).
SW7		Off		
SW8		Off		

To operate the indoor unit without Internal Electric Heater , Dip switch 1, 2, 6, 8 must be set OFF .

To operate the indoor unit with Internal Electric heater , Dip switch 6 must be set ON.

- SW6 ON: Automatic Heater operation: Heater operates automatically.
- SW6 OFF: Manual Heater operation: Owner 's involvement is required for on/off operation.

If you operate the indoor unit with Internal Electric heater with Dip switch 5, note the following:

- SW5 ON: Fan operates continuously. During defrosting or oil return operation, uninterrupted heating can be attained, as a result of continuous heater and fan operation.
- SW5 OFF: Fan discontinuous operation. There would be a reduction in heating capacity while defrosting or oil return operation.

Factory Supplied Materials

- Owner's Manual
- Installation Manual
- Simple Controller with Mode Selection (AKB72955816)¹

¹Simple Mode Controllers for the vertical-horizontal air handling indoor units are also referenced by Model No. PQRCVCL0QW.

Required Tools

- Level
- Screwdriver
- Electric drill
- Hole core drill
- Flaring tool set
- Torque wrenches
- Hexagonal wrench
- Gas-leak detector
- Thermometer

⚠ WARNING

Installation work must be performed by trained personnel and in accordance with national wiring standards and all local or other applicable codes. Improper installation can result in fire, electric shock, physical injury, or death.

Note:

Read all instructions before installing this product. Become familiar with the unit's components and connections, and the order of installation. Incorrect installation can degrade or prevent proper operation.

Selecting the Best Location

Do's

- Place the unit where air circulation through the ducts will not be blocked.
- Place the unit where drainage can be obtained easily.
- Place the unit where noise prevention is taken into consideration.
- Ensure there is sufficient strength to bear the load of the indoor unit.
- Ensure there is sufficient maintenance space.
- Locate the indoor unit in a location that is level, and where it can be easily connected to the outdoor unit / branch distribution unit.

Note:

If the unit is installed near a body of water, certain components are at risk of being corroded. Appropriate anti-corrosion methods should be taken for the unit and all components.

Volatle Organic Compounds

Indoor Units (IDUs) should not be placed in an environment where the IDUs may be exposed to harmful volatile organic compounds (VOCs) or in environments where there is improper air make up or supply or inadequate ventilation. If there are concerns about VOCs in the environment where the IDUs are installed, proper air make up or supply and/or adequate ventilation should be provided. Additionally, in buildings where IDUs will be exposed to VOCs consider a factory-applied epoxy coating to the fan coils for each IDU.

Installing in an Area Exposed to Unconditioned Air

In some installation applications, areas (floors, walls) in some rooms may be exposed to unconditioned air (room may be above or next to an unheated garage or storeroom). To countermeasure:





- Verify that carpet is or will be installed (carpet may increase the temperature by three degrees).
- Add insulation between the floor joists.
- Install radiant heat or another type of heating system to the floor.

Installing in an Area with High Humidity Levels

If the environment is prone to humidity levels of 80% or more (near the ocean, lakes, etc.) or where steam could collect in the plenum:

- Install additional insulation to the indoor unit (glass wool insulation >13/32 inches thick).
- Install additional insulation to the refrigerant piping (insulation >13/16 inches thick).
- Seal all gaps between the indoor unit and the ceiling tiles (make the area air tight) so that humidity does not transfer from the plenum to the conditioned space. Also, add a ceiling grille for ventilation.

Don'ts

-  Do not install the unit near a heat or steam source, or where considerable amounts of oil, iron powder, or flour are used.
-  Do not install the unit where sulfuric acid and flammable or corrosive gases are generated, vented into, or stored.
-  Do not install the unit near high-frequency generators.
-  Do not install the unit near a doorway.

The unit may be damaged, may malfunction, and/or will not operate as designed if installed in any of the conditions listed.

FOUR-WAY VAHU INDOOR UNITS

Installation and Best Layout Practices

MULTI F
MULTI F MAX

Figure 229: Clearance Requirements.

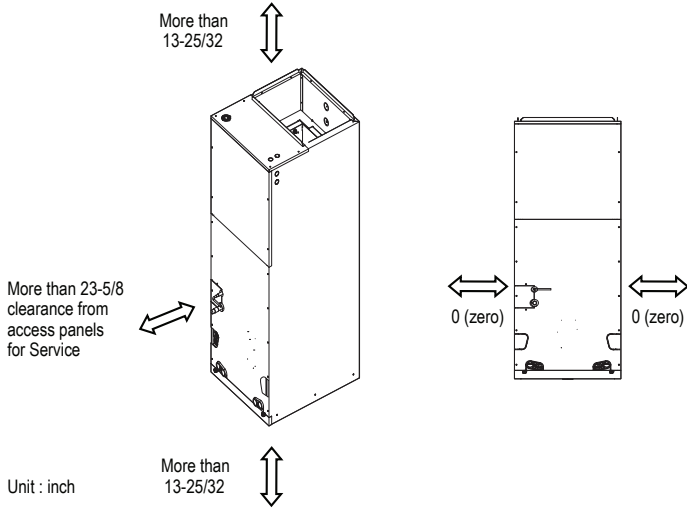

Figure 230: General and Duct Connection Dimensions.

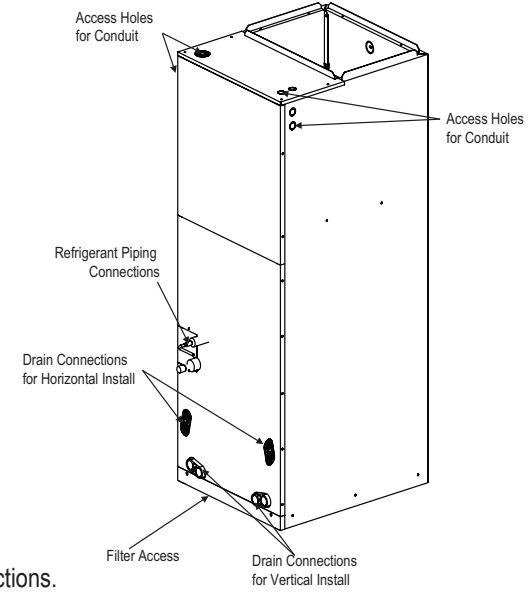
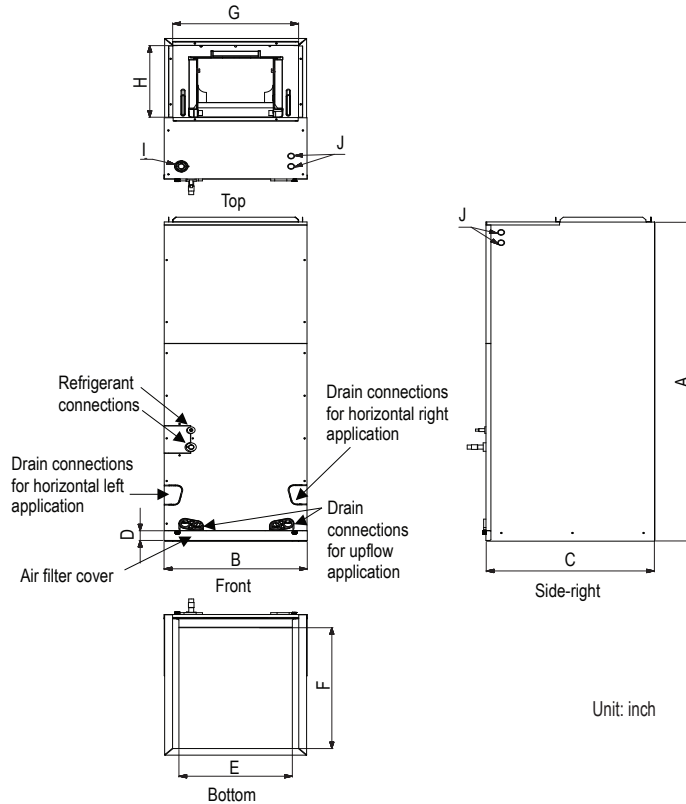

Figure 231: Location of Access Holes and Piping Connections.



ODU	VAHU Capacity (kBtu/h)	Dimensions								Wiring Knock out		Refrigerant Pipe size		Refrigerant Pipe Connections		
		A	B	C	D		E	F	G	H	I	J	Liquid	Gas	Liquid	Gas
		Height	Width	Depth							Power	Comm-unication				
Multi Zone	18 24	48-5/8	18	21-3/8	1-9/16	17-1/2	20	17	12-1/8	1-11/16	7/8	1/4	1/2	3/8	5/8	
	36	55-1/8	25	21-3/8	1-9/16	24-1/2	20	24	12-1/8	1-11/16	7/8	3/8	5/8	3/8	5/8	

Note:

Vertical-Horizontal Air Handling Units can be installed in a choice of vertical upflow, vertical downflow (with optional downflow kit), or horizontal (left or right side) configurations.

Vertical (Upflow) Installation

- Unit must be positioned properly for plenum / duct installation.
- To maintain proper air flow, minimum height clearance is 14 inches.
- Plenum must be strong and secure enough to support the installation of adapter collars to accommodate duct work.
- Air handler platform should be sturdy enough to support the frame, plus any accessories (e.g., filter box).
- To prevent air leaks, seal all duct work according to local codes, but make sure that filter access is still unobstructed.
- Vibration isolators (field supplied) must be installed between the unit frame and the platform. If necessary, provide the installing contractor with an illustration of where the vibration isolator should be added and how it should be positioned.

Note:

⊘ Do not install the screws on the front and back of the unit; doing so may block filter installation.

Vertical (Downflow) Installation

The Vertical-Horizontal Air Handling Unit can be field-converted to vertical downflow operation. The optional vertical downflow kit is required. Downflow kit PNDFJ0 is required for 18-24MBH NJ chassis units and downflow kit PNDFK0 is required for 36MBH NK chassis units. The coil must be removed and repositioned in the chassis with the brackets of the downflow kit. For installation details, refer to the instructions included with the kit.

Figure 232: Vertical Installation / Attaching the Bottom Duct.

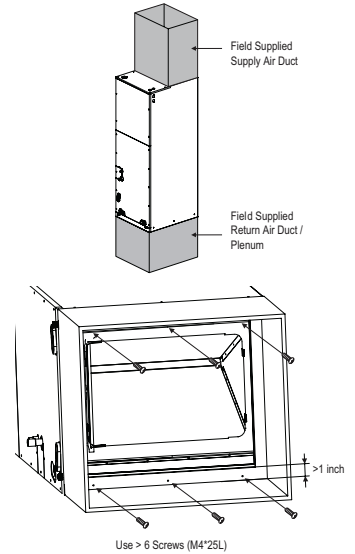
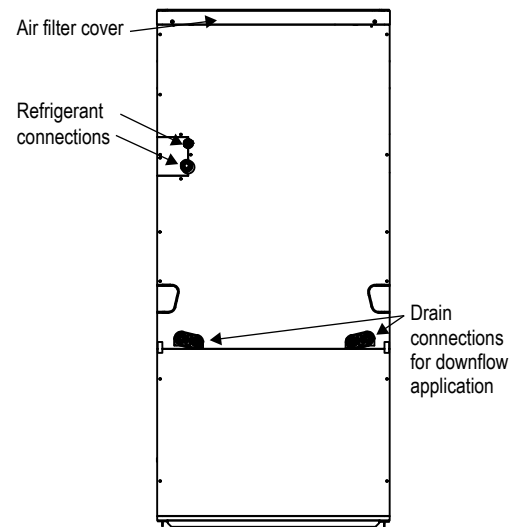

Figure 233: Chassis after Downflow Field Conversion.



FOUR-WAY VAHU INDOOR UNITS

Installation and Best Layout Practices

MULTI F
MULTI F MAX

Horizontal Installation

- Units may be installed in horizontal left or horizontal right configuration. Horizontal left is the factory default configuration. For horizontal right, the unit must be field converted. The horizontal right conversion requires removing the internal drain pan from the left side of the unit and reinstalling on the right side. No conversion kit is required. Refer to the installation manual for details.
- Units must be installed so that the access panels face to the side, not facing up or down.
- Installation must be in accordance with all relevant building codes, which may necessitate the installation of an external condensate pan (position the unit in or above the external condensate pan).
- If the units are going to be suspended, use angled steel support brackets with threaded rods to provide support from the bottom. The brackets / threaded rods should be comparatively bigger / longer than the unit, and each must be centered on the part of the frame it supports.
- If the unit will not be suspended, use angled steel support brackets, but also add vibration isolators (field supplied) to avoid sound transmission. If necessary, provide the installing contractor with an illustration of where the vibration isolator should be added and how it should be positioned.
- Unit must be positioned properly for plenum / duct installation.
- Plenum must be strong and secure enough to support the installation of adapter collars to accommodate duct work.

Note:

To ensure proper drainage for horizontal installations, unit must be installed within $\pm 1/8$ inches level of the unit's length and width.

Figure 234: Typical Horizontal Left Installation.

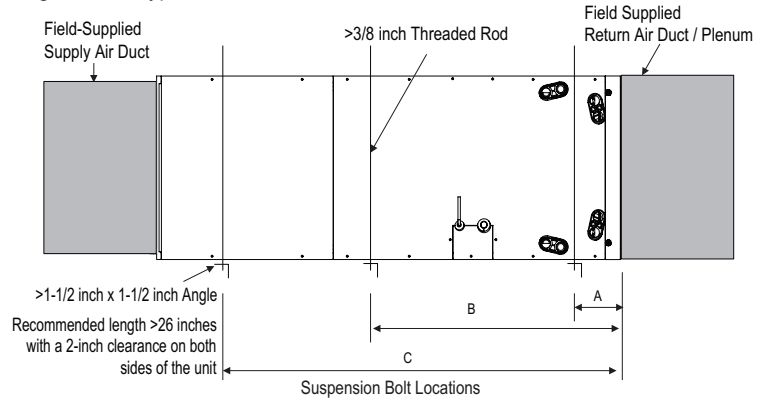

Figure 235: Typical Horizontal Right Installation.

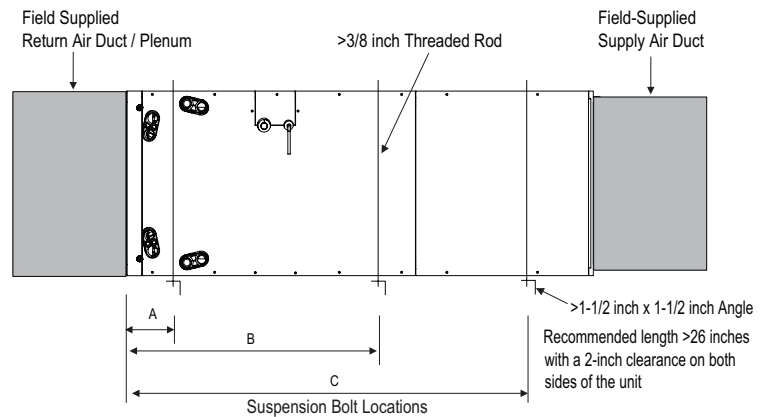

Table 109: Bracket / Bolt Position Dimensions for Horizontal Left and Horizontal Right Installation.

Capacity (Btu/h)	Dimensions (inches)		
	A	B	C
18,000	4	23	41-11/32
24,000	4	23	41-11/32
36,000	4	29	48

Installing the Ducts

- Use more than ten (10) screws to securely attach the supply ducts to the unit. To prevent air leaks, seal around the duct opening before the duct is secure.
- To prevent vibration transmission, install flexible connectors between ducts and the unit. The flexible connectors must be made of a heat-resistant material at the discharge connection if an electric heater is installed.
- Duct work must be insulated and covered with vapor barrier when routed through unconditioned spaces. Include enough insulation to prevent condensate from forming on the ducts.
- It may be necessary to add internal acoustical insulation lining for a metal duct system if it does not include a 90° elbow and ten (10) feet between the main duct and the first branch.
- Fibrous glass ducts could be used as a substitute if built and installed in accordance with the most recent edition of the Sheet Metal and Air-Conditioning Contractors' National Associate (SMACNA) standard.
- Also, fibrous duct work and acoustical insulation lining must also follow National Fire Protection Standard 90A or B as tested by UL Standard 181 for Class 1 air ducts.

Figure 236: Securing the Ducts to the Unit.

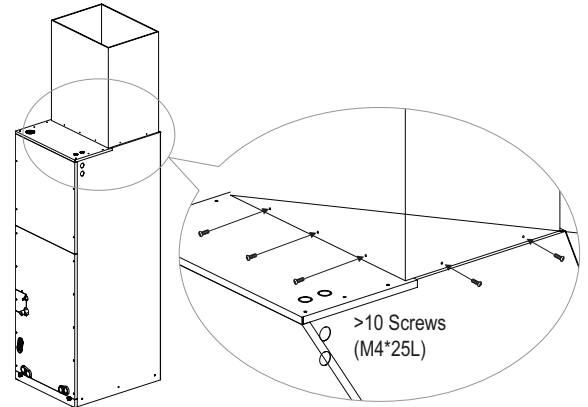

Installing the Drain System

General Specifications

- To prevent property damage, optimize drain system performance by installing both a primary and secondary drain line, and properly size the condensate traps.
- The primary and secondary drain line must be trapped to allow proper drainage of condensate water. If the secondary drain line is not used, it must be capped.
- Do not block the filter access panel when installing the condensate drain piping. Prime the primary and secondary condensate traps after running both to the drain pan.
- If the unit is installed above an inhabited space, add a field-supplied external condensate pan that runs underneath the entire frame (to prevent damage from overflow). The additional external condensate line should run from the unit to the external condensate pan.
- Drain all generated condensate from the external condensate pan to an appropriate area. Install a trap in the condensate lines as near to the indoor unit coil as possible.
- For horizontal right operation, the drain pan must be removed from the interior left side of the unit and reinstalled on the right side.
- All condensate must be drained from the external condensate pan to some noticeable area.
- To prevent overflow, the outlet of each trap should be positioned below its connection to the condensate pan.
- All traps should be primed, insulated, and leak tested if located above an inhabited space.
- Use a 3/4-inch PVC male pipe thread fitting at the condensate pan connection. Tighten gently.
- Point the drain hose down for easier flow.
- Do not just use the pipe joint or PVC / CPVC piping on the indoor unit drain line connections. Use only Teflon tape.
- Design the drain system to plan for winter operation (condensate line may freeze up if condensate does not properly drain away).

Figure 237: Typical Vertical Up/Down Installation Drain System.

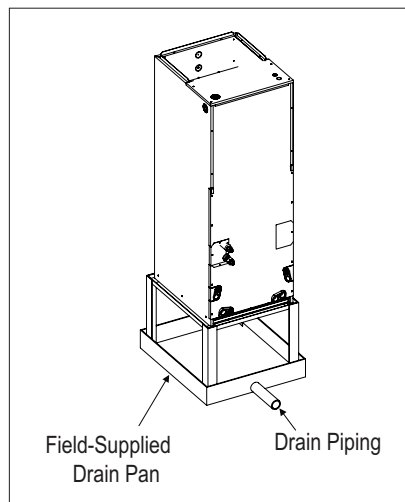
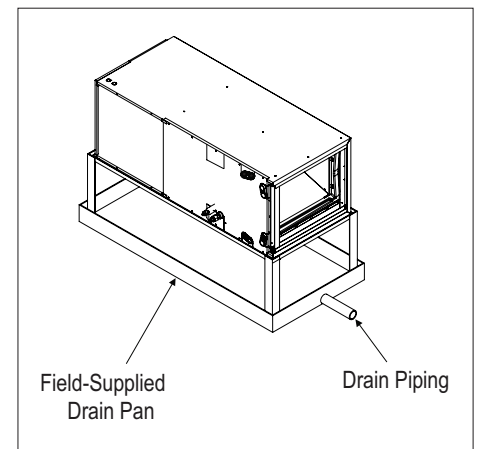

Figure 238: Typical Horizontal Left/Right Installation Drain System.



FOUR-WAY VAHU INDOOR UNITS

Installation and Best Layout Practices

MULTI F
MULTI F MAX

Drain Piping Specifications

- Drain piping must have downward gradient of at least 1/50 to 1/100; to prevent reverse flow, slope should not be straight up and down.
- Do not damage the drain port on the indoor unit when connecting the field-supplied drain piping.

Figure 239: Close up of Drain Piping Connection.

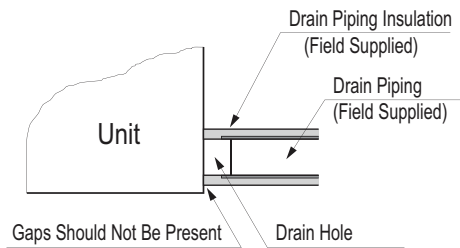

Insulating the Refrigerant and Drain Piping

⚠ WARNING

Ensure all piping is insulated. Exposed piping can cause burns if touched.

Refrigerant Piping Insulation

Field-installed vapor and liquid refrigerant piping lines must be properly and completely covered in insulation (up to the indoor unit piping connections) and must comply with federal, state, and local requirements. Any exposed piping may generate condensate or will cause burns if touched. Insulation for this field-installed refrigerant piping must have a minimum heat resistance of 248°F.

If the indoor unit is installed and is operated at an extended period in a highly humid environment (dew point temperature >73°F), however, condensate will form. To prevent this phenomenon, install adiabatic glass wool insulation with a thickness of 7/16 to 13/16 inches thick. Also, install glass wool insulation on all indoor units that are located in the ceiling plenum.

Drain Piping Insulation

Drain piping insulation must be 7/32 inches thick, minimum.

Figure 243: Close Up of Refrigerant Piping Connection Insulation.

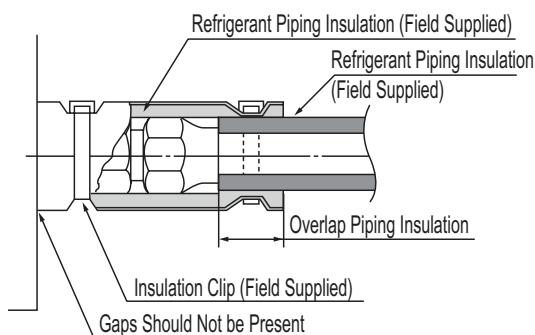

Field-Installed U-Trap Specifications

Note:

To prevent leaks cause by a block in the intake air filter, install a U-Trap.

A ≥ 2-9/16 inches

B ≥ 2C

C ≥ 2 x SP

SP = External Pressure in. WG

Example:

External Pressure = 0.4 in WG

A ≥ 2-9/16 inches

B ≥ 1-7/12 inches

C ≥ 19/24 inches

Figure 240: Installing the U-Trap.

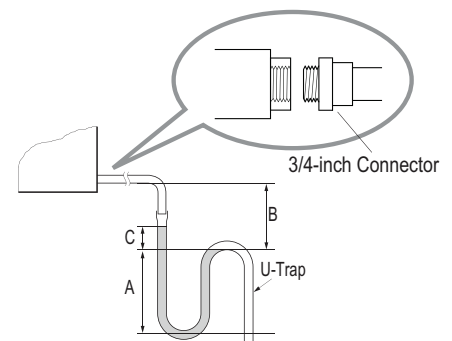

Figure 241: Vertical Primary and Secondary Drain Layout.

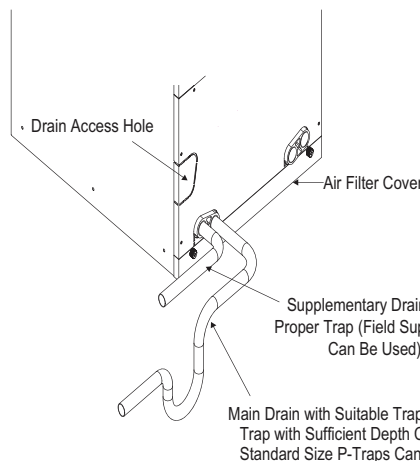

Figure 242: Horizontal Primary and Secondary Drain Layout.

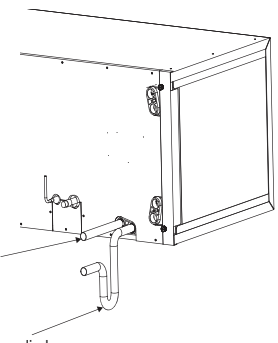
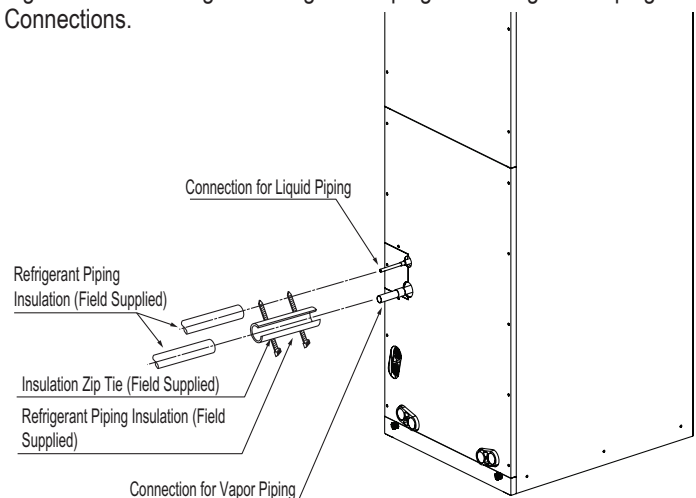

Figure 244: Insulating the Refrigerant Piping and Refrigerant Piping Connections.



Power Wiring / Communications Cable Guidelines

- Follow manufacturer's circuit diagrams in the technical manuals.
- Confirm power source specifications.
- Confirm that the electrical capacity is sufficient.
- Starting current must be maintained ± 10 percent of the rated current marked on the outdoor unit name plate.
- Confirm cable thickness specifications.
- It is recommended that a circuit breaker is installed, especially if conditions could become wet or moist.
- Include a disconnect in the power wiring system, add an air gap contact separation of at least 1/8 inch in each active (phase) conductor.

⚠ WARNING

• Loose wiring may cause unit to malfunction, overheat, and catch fire, resulting in severe injury or death.

Note:

- Terminal screws may become loose during transport. Properly tighten the terminal connections during installation.
- A voltage drop may cause the following problems:
- Magnetic switch vibration, fuse breaks, or disturbance to the normal function of an overload protection device.
 - Compressor will not receive the proper starting current.

Connecting the Power Wiring and Communications Cable

1. To access the terminal block, first unscrew the top front panel, and then unscrew the cover from the control box.
2. Knockout the access holes for the wiring. Insert the power wiring/communications cable from the outdoor unit or branch distribution unit (Multi F MAX systems only) through the conduits, pass the conduits through the designated access holes, and then insert the conduits into the control box. To prevent electromagnetic interference and product malfunction, leave a space between the power wiring and communications cable outside of the indoor unit.
3. Connect the power wiring and communications cables to the appropriate terminals on the indoor unit control board. Verify that the color and terminal numbers from the outdoor unit or branch distribution unit (Multi F MAX systems only) wiring match the color and terminal numbers on the indoor unit.
4. Fill in any gaps around the conduit access holes with sealant to prevent foreign particles from entering the indoor unit.

Figure 245: Connecting the Power Wiring and Communications Cable.

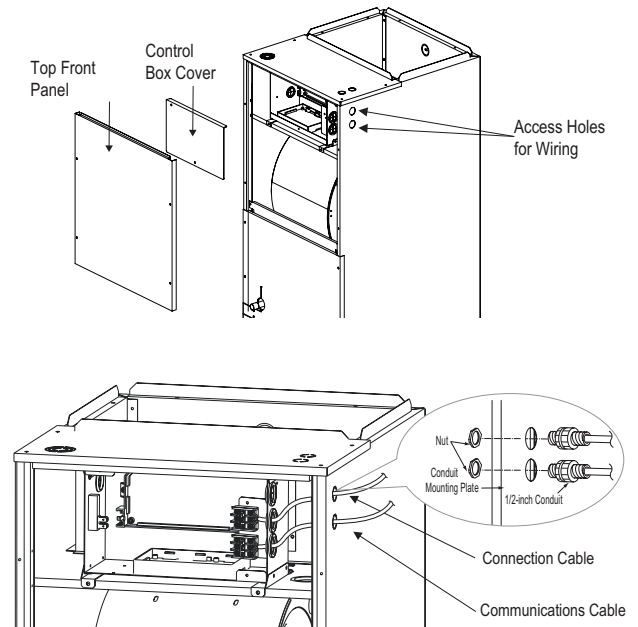
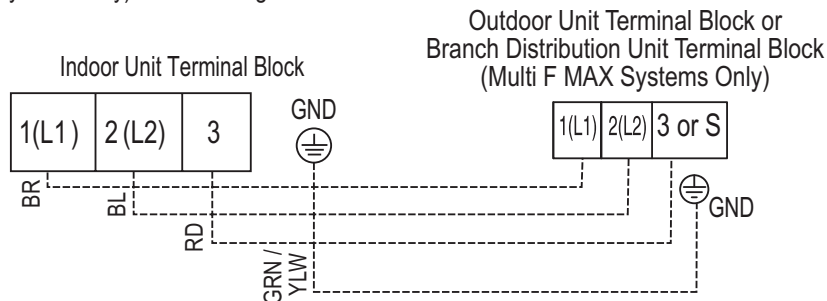

Figure 246: Indoor Unit to Outdoor Unit / Branch Distribution Unit (Multi F MAX systems only) Power Wiring / Communications Cable Connections.



FOUR-WAY VAHU INDOOR UNITS

Installation and Best Layout Practices

MULTI F
MULTI F MAX

Controller Options

Vertical-Horizontal Air Handling indoor units include an LG-supplied wired controller (AKB72955816)¹, but other optional LG-supplied wired controllers are available. The wireless handheld controller (Model No. PQWRHQ0FDB) is also an optional accessory with use of the wired controller.

- Operation Display Panel: Displays operation conditions.
- Temperature Control Button: Sets desired temperature.
- Fan Speed Button: Sets desired fan speed.
- On / Off Button: Turns system operation on and off.
- Mode Selection Check Button: Selects the operation mode: Cooling, Heating, Auto, Dry (Dehumidification), or Fan.

Note:

Each function will display on the LED for about three (3) seconds when the power is first cycled on.

AKB72955816¹ Wired Controller.

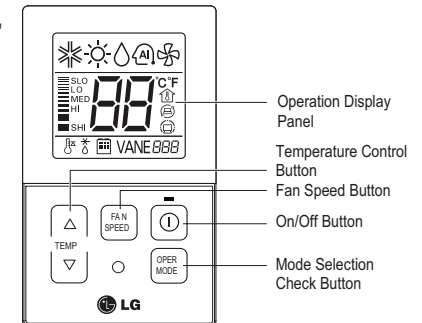

¹Simple Mode Controllers for the vertical-horizontal air handling indoor units are also referenced by Model No. PQRCVCLQW.

Wired Controller Connections

Controllers can connect to the indoor unit in one of two different ways.

1. LG Wired Remote Extension Cable with Molex plug (PZCWRC1; sold separately) that connects to the CN-REMO terminal on the indoor unit PCB.
2. Field-supplied controller cable that connects to the indoor unit terminal block (must be at least UL2547 or UL1007, 22 AWG, two-core, one-shield core, at least FT-6 rated if local electric and building codes require plenum cable usage).

Figure 247:PZCWRC1 LG Wired Remote Extension Cable.

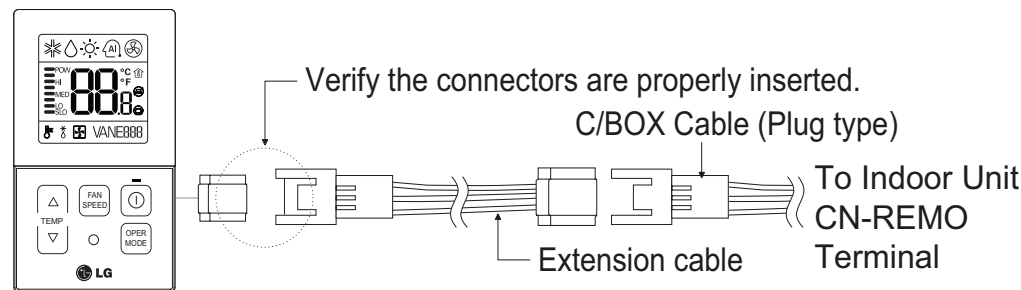
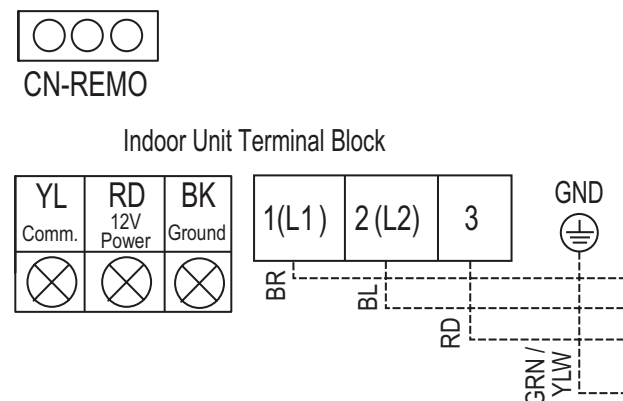

Figure 248:Wired Controller Connection on the Indoor Unit Terminal Block.



Note:

When using field-supplied controller cable, make sure to connect the yellow to yellow (communications wire), red to red (12V power wire), and black to black (ground wire) terminals from the remote controller to the indoor unit terminal blocks.

Wired Controller Placement

Wired controllers include a sensor to detect room temperature. To maintain comfort levels in the conditioned space, the wired controller must be installed in a location away from direct sunlight, high humidity, and where it could be directly exposed to cold air. Controller must be installed four (4) to five (5) feet above the floor where its LED display can be read easily, in an area with good air circulation, and where it can detect an average room temperature.

⊘ Do not install the wired controller near or in:

- Drafts or dead spots behind doors and in corners
- Hot or cold air from ducts
- Radiant heat from the sun or appliances
- Concealed pipes and chimneys
- An area where temperatures are uncontrolled, such as an outside wall

Hanging the Wired Controller

1. The controller wiring / cable can be installed in one of three directions: top, back, or on the right side. If top or right side installation is desired, remove cable guide grooves on the controller, and then position wiring / cable on applicable side.
2. Choose and mark the area of installation, and then screw the wall plate into place (using the provided parts). Install the controller wall plate to fit the electrical box if one is present. Ensure that no gaps exist between the wall plate and the wall itself.
3. Arrange wiring / cables so as not to interfere with the controller circuitry. Position the wired controller on the wall plate. Snap into place by pressing the bottom part of the wired controller onto the wall plate. Make sure that no gaps exist between the wired controller and the wall plate on all sides.
4. To remove wired controller from the wall plate, insert a screwdriver into the two holes at the bottom. Twist screwdriver to release controller. ⊘ Do not damage the controller components when removing.

Figure 249: Proper Location for the Wired Controller.

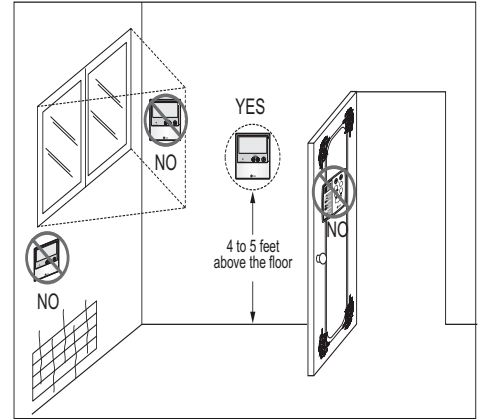

Figure 250: Removing the Cable Guide Grooves.

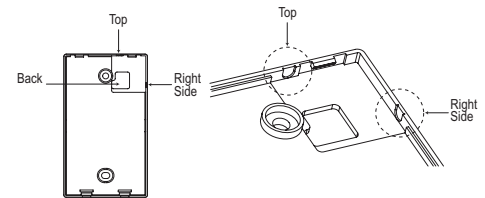

Figure 251: Attaching the Wall Plate.

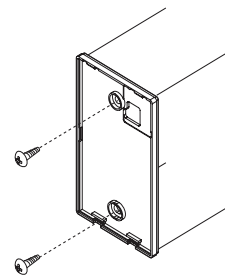
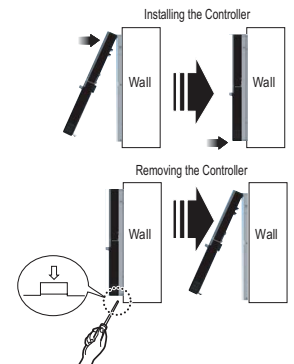

Figure 252: Installing / Removing the Controller.



Assigning the Thermistor for Temperature Detection

Each indoor unit includes a return air thermistor assigned to sense the temperature. If a wired controller is installed, there is a choice of sensing temperature with either the indoor unit return air thermistor or the thermistor in the wired controller. It is also an option to set both thermistors to sense temperature so that indoor unit bases its operation on the first thermistor to reach the designated temperature differential. For applicable indoor units, an optional Remote Temperature Sensor can be used in lieu of the return air thermistor—either alone or in conjunction with a wired controller thermistor as previously described.

APPLICATION GUIDELINES

“Equipment Selection Procedure” on page 184

“Placement Considerations” on page 191

To choose the multi-zone system that is the most appropriate for the space, as with traditional air-conditioning systems, follow similar protocols outlined in Manual J from the Air Conditioning Contractors of America (ACCA; see www.acca.org).

1. Obtain the design conditions, and calculate the maximum cool and heat loads for the structure.
2. Select the equipment (choosing the appropriate indoor units and outdoor unit):
 - Determine number of zones.
 - Determine total number of indoor units (refer to zone load calculations when choosing indoor units).
 - Determine number of indoor units allocated to each outdoor unit, considering allowable indoor unit connections, both indoor unit and outdoor unit capacities, and system piping capabilities.
3. Determine the corrected capacity for the indoor units and outdoor unit using LATS Multi F software (preferred method) or:
 - System Combination Tables.
 - Capacity Tables (it may be necessary to interpolate).
 - Capacity Coefficient Factors (such as refrigerant line length derates, design condition derates, defrost operation derate [heating mode], altitude derate [if applicable]).
4. Compare corrected capacities to load calculations.
5. Reselect equipment if necessary.

Obtain Design Conditions, Calculate Maximum Cool / Heat Loads

Obtain the winter outdoor / indoor temperature and summer and winter outdoor / indoor temperature design parameters for the location in which the system is installed. Determine if summer or winter design gains, relative humidity, and building features like skylights, orientation, number of occupants, etc., would change the total heat loss / gain and sensible / latent heat gain, and then calculate the maximum cool and heat loads for the space (using Manual J or energy modeling programs).

Select the Equipment

Determine the Number of Zones

Multi F and Multi F with LG RED heat pump systems can cool or heat, but not simultaneously. When designing larger-capacity Multi F heat pump systems or a Multi F MAX system, the designer may be able to combine spaces with similar load profiles located near or adjacent to each other into “thermal zones.” After combining like spaces into zones that will be served by a single (or grouped) indoor unit(s), calculate the peak cooling and heating loads for each zone.

Choosing the Appropriate Indoor Units

Determine the appropriate indoor unit capacity that satisfies the given zone load calculations, and choose how many (and which styles of) indoor units will be required. See Table 90 for allowable indoor unit to outdoor unit connections, and the maximum number of connectable indoor units on each Multi F and Multi F MAX outdoor unit. When choosing indoor units, also consider the cooling and heating CFM, featured airflow specifications, and static pressure (if applicable) for each indoor unit.

Avoid oversizing indoor units in an attempt to increase the air exchange rate in the space. Multi F and Multi F MAX systems are designed for minimum airflow over the coil to maximize latent capacity while cooling, maintain a comfortable, consistent discharge air temperature while heating, and minimize fan motor power consumption. In extreme cases, oversizing the indoor units may affect outdoor unit size selection and compromise the outdoor unit’s ability to effectively match the space load(s).

For proper system operation:

1. At least two indoor units must be connected to the outdoor unit.
2. Total connected indoor unit nominal capacity should be a minimum 40% and a maximum of 133% of outdoor unit nominal capacity.
3. To calculate the connected total indoor unit nominal capacity, simply sum up the nominal capacities of all indoor units.
 - For high static duct and vertical-horizontal air handling indoor units, a 1.3 multiplier must first be applied before adding to the sum of other indoor units.
 - When high static duct and / or vertical-horizontal air handling indoor units are the only connected indoor units, the multiplier is 1.2.

Note:

For allocated capacity information, see the combination tables in the “Multi F / Multi F MAX Combination Data Manual” on www.lg-dfs.com. For performance data, see “Multi F / Multi F MAX Performance Data Manual” on www.lg-dfs.com. Also refer to the appropriate manuals on www.lg-dfs.com for combination and capacity data for Multi F with LG RED / Multi F MAX with LG RED units.

Multiplier Examples

Example 1

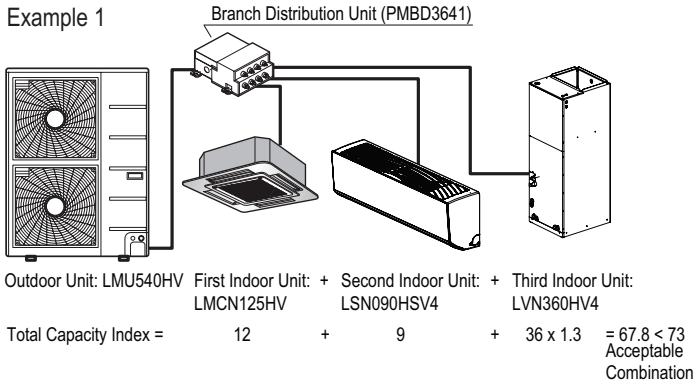

Example 2

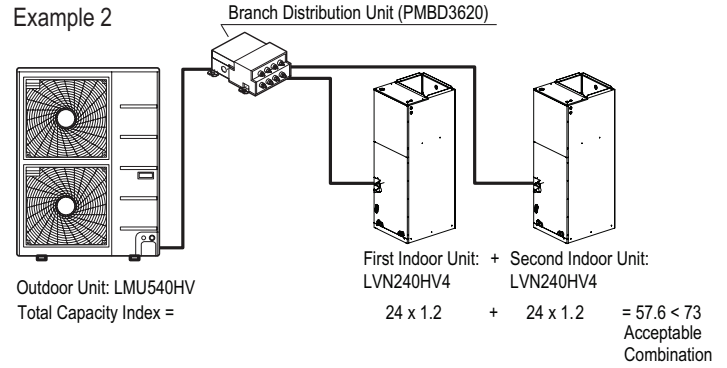

Table 110: Allowable Indoor Unit to Multi F/ Multi F MAX Outdoor Unit Connections.

Indoor units		Outdoor units						
Model Type	Indoor Unit Nominal Capacity (Btu/h)	LMU18CHV	LMU24CHV	LMU30CHV	LMU36CHV	LMU480HV	LMU540HV	LMU600HV
		Maximum No. of Connectable Indoor Units						
		2	3	4	4	8	8	8
ART COOL Mirror	9,000	0	0	0	0	0	0	0
	12,000	0	0	0	0	0	0	0
	18,000	-	0	0	0	0	0	0
ART COOL Gallery	9,000	0	0	0	0	0	0	0
	12,000	0	0	0	0	0	0	0
	18,000	0	0	0	0	0	0	0
Standard Wall Mounted	7,000	0	0	0	0	0	0	0
	9,000	0	0	0	0	0	0	0
	12,000	0	0	0	0	0	0	0
	15,000	0	0	0	0	0	0	0
	18,000	-	0	0	0	0	0	0
Ceiling Concealed Duct-Low Static	24,000	-	0	0	0	0	0	0
	9,000	0	0	0	0	0	0	0
	12,000	0	0	0	0	0	0	0
	18,000	-	0	0	0	0	0	0
Ceiling Concealed Duct-High Static	24,000	-	-	0	0	0	0	0
	36,000	-	-	-	-	0	0	0
Four-Way Ceiling Cassette	7,000	0	0	0	0	0	0	0
	9,000	0	0	0	0	0	0	0
	12,000	0	0	0	0	0	0	0
	18,000	-	0	0	0	0	0	0
Vertical-Horizontal Air Handler	18,000	-	0	0	0	0	0	0
	24,000	-	-	0	0	0	0	0
	36,000	-	-	-	-	0	0	0

Table 112: Allowable Indoor Unit to Multi F/ Multi F MAX with LGRED Outdoor Unit Connections.

Indoor units		Outdoor units				
Model Type	Indoor Unit Nominal Capacity (Btu/h)	LMU180HHV	LMU240HHV	LMU300HHV	LMU360HHV	LMU420HHV
		Maximum No. of Connectable Indoor Units				
		2	3	4	5	6
ART COOL Mirror	9,000	0	0	0	0	0
	12,000	0	0	0	0	0
	18,000	-	0	0	0	0
ART COOL Gallery	9,000	0	0	0	0	0
	12,000	0	0	0	0	0
Standard Wall Mounted	7,000	0	0	0	0	0
	9,000	0	0	0	0	0
	12,000	0	0	0	0	0
	15,000	0	0	0	0	0
	18,000	-	0	0	0	0
Ceiling Concealed Duct- Low Static	24,000	-	0	0	0	0
	9,000	0	0	0	0	0
	12,000	0	0	0	0	0
	18,000	-	0	0	0	0
Ceiling Concealed Duct- High Static	24,000	-	-	0	0	0
	36,000	-	-	-	-	0
Four-Way Ceiling Cassette	7,000	0	0	0	0	0
	9,000	0	0	0	0	0
	12,000	0	0	0	0	0
	18,000	-	0	0	0	0
Vertical-Horizontal Air Handler	18,000	-	0	0	0	0
	24,000	-	-	0	0	0
	36,000	-	-	-	-	0

Choosing the Appropriate Outdoor Unit

After all indoor units are properly sized to offset the applicable loads in each zone, select the outdoor unit by choosing a size that meets both the load-cooling requirement, and offsets the sum of the heating load. Then, the system's combination ratio should be evaluated and confirmed it is within the allowable range (the combination ratio compares the nominal capacity of all connected indoor units to the nominal capacity of the outdoor unit serving them). The total nominal capacity of all indoor units should be smaller than the total nominal capacity of the outdoor unit. If the combination ratio is more than 100%, the designer is undersizing the outdoor unit relative to the combined nominal capacity of the connected indoor units. In some designs, oversized indoor units may be unavoidable in the case where the smallest size indoor unit available from LG is larger than what is necessary to satisfy the zone load. This scenario may also occur when an indoor unit selection one size down from the selected unit is slightly short of fulfilling the design load requirements, and the designer must choose the next largest size unit. Sometimes it is recommended to choose a larger capacity outdoor unit if the installation space is big enough. Also, it may be prudent to oversize the outdoor unit to address those times when the weather conditions may exceed the design conditions, to minimize the possibility of ventilation systems that causes the space temperature to drift outside design parameters, or when the indoor unit's entering air temperature falls outside the approved design temperature range.

Table 111: Multi F/ Multi F Max Rated Outdoor Unit Capacity.

		Outdoor Units						
		LMU18CHV	LMU24CHV	LMU30CHV	LMU36CHV	LMU480HV	LMU540HV	LMU600HV
Rated Capacity (Btu/h)*	Cooling	17,000	20,000	30,000	32,000	48,000	52,500	60,000
	Heating	22,000	24,000	32,000	36,000	54,000	58,000	64,000
Connectable Indoor Units	Minimum No. of Connectable IDUs	2	2	2	2	2	2	2
	Maximum No. of Connectable IDUs	2	3	4	4	8	8	8
	Maximum Capacity Index	24,000	33,000	40,000	48,000	65,000	73,000	81,000

Table 113: Multi F/ Multi F Max with LGRED Rated Outdoor Unit Capacity.

		Outdoor Units				
		LMU180HHV	LMU240HHV	LMU300HHV	LMU360HHV	LMU420HHV
Rated Capacity (Btu/h)*	Cooling	18,000	24,000	28,400	36,000	42,000
	Heating	22,000	26,000	28,600	41,000	45,000
Connectable Indoor Units	Minimum No. of Connectable IDUs	2	2	2	2	2
	Maximum No. of Connectable IDUs	2	3	4	5	6
	Maximum Capacity Index	24,000	33,000	40,000	48,000	56,000

Determine the Corrected Capacity

The *corrected* cooling / heating capacity is different from the rated cooling / heating capacity. The corrected capacity includes changes in unit performance after considering design temperatures, available capacity that can be allocated from the outdoor unit, pressure drop due to refrigerant line length, defrost operation in heating mode, and (if applicable) altitude. Depending on the location of the building, additional capacity correction factors may need to be applied.

Using the Outdoor Unit Cooling and Heating Capacity Tables

Rated cooling capacity ratings are obtained with air entering the indoor unit at 80°F dry bulb (DB) and 67°F wet bulb (WB), and outdoor ambient conditions of 95°F dry bulb (DB) and 75°F wet bulb (WB). Rated heating capacity ratings are obtained with air entering the indoor unit at 70°F dry bulb (DB) and 60°F wet bulb (WB) and outdoor ambient conditions of 47°F dry bulb (DB) and 43°F wet bulb (WB).

To evaluate the total outdoor unit capacity at design conditions perform a selection using LATS Multi F software (preferred method) or reference the Performance Data Capacity Tables found in the Multi F outdoor unit section in this manual. All design temperatures are not explicitly shown in the charts, therefore, interpolation may be necessary to calculate the capacity for specific design conditions. Based on the premise that capacity follows a linear curve, the following formula can be applied:

$$(y - y_1) / (y_2 - y_1) = (x - x_1) / (x_2 - x_1)$$

Where

- y = Missing Capacity (Capacity at the Design Temperature).¹
- y1 = Capacity at Lower Temperature (Smaller value of the two nearest published TC datapoints).
- y2 = Capacity at Higher Temperature (Higher value of the two nearest published TC datapoints).
- x = Design Temperature (Temperature not shown in published capacity tables).²
- x1 = (Smaller value of the two nearest published temperature datapoints).
- x2 = (Larger value of the two nearest published temperature datapoints).

¹Median between two published Total Capacity [TC] Btu/h datapoints in the capacity table.

²Median between two nearest published temperature datapoints.

Using the Indoor Unit Cooling and Heating Capacity Tables

The datapoints shown in the indoor unit cooling and heating capacity charts are based on (and convey) an indoor unit operating with maximum possible refrigerant flow from the outdoor unit and before any derates are applied. In other words, the capacities displayed reflect what the indoor unit would produce if it was the only indoor unit that required capacity, and the outdoor unit did not have to allocate any capacity to another indoor unit.

System operation with a combination of indoor units is not conveyed in these charts, however, the information can be used to calculate indoor unit allocated capacity (without using the system combination tables). Simply calculate by using the formula:

$$Q_{idu}(combi) = Q_{odu}(rated) \times \frac{Q_{idu}(rated)}{\Sigma Q_{idu}(rated)}$$

Where

- Q_{idu}(combi) = Individual Indoor Unit Combination Capacity.
- Q_{odu}(rated) = Outdoor Unit Rated Capacity.
- Q_{idu}(rated) = Individual Indoor Unit Rated Capacity.
- ΣQ_{idu}(rated) = Total Connected Indoor Unit Rated Capacity.

Note:

- The formula can be used to find individual indoor unit capacity for Multi F MAX systems.
- A more accurate method to determine expected capacity would be to apply the outdoor unit's corrected capacity instead of rated capacity.



Using the System Combination Tables

Multi F system combination tables illustrate how each indoor unit receives a percentage of total outdoor unit rated capacity. Allocation is based on:

- Combinations of Non-Ducted Indoor Units
- Combinations of Ducted Indoor Units
- Combinations of Mixed Non-Ducted and Ducted Indoor Units

Multi F MAX system combination tables only show the total connected indoor unit capacity, but individual indoor unit capacity can be calculated using the formula:

$$Q_{idu}(\text{combi}) = Q_{odu}(\text{rated}) \times \frac{Q_{idu}(\text{rated})}{\sum Q_{idu}(\text{rated})}$$

Note:

A more accurate method to determine expected capacity would be to apply the outdoor unit's corrected capacity instead of rated capacity.

Capacity Coefficient Factors

Refrigerant Line Length Derates

For air-cooled systems, a capacity correction factor may have to be applied to account for the length of the system's refrigerant pipe. Rate of change in capacity due to increased piping lengths is shown in Table 114, Table 11593, and Table 11694.

Table 114: Multi F Outdoor Unit (Multiple Piping) to Indoor Unit Refrigerant Line Length Derates.

Piping Length (feet)	Cooling Capacity (%)	Heating Capacity (%)
7,000 Btu/h Indoor Unit Models		
25.0	100.0	100.0
32.8	98.4	99.2
49.2	95.8	97.8
65.6	93.2	96.4
82.0	90.6	95.0
9,000 Btu/h Indoor Unit Models		
25.0	100.0	100.0
32.8	98.0	99.0
49.2	94.8	97.4
65.6	91.6	95.8
82.0	88.4	94.2
12,000 Btu/h Indoor Unit Models		
25.0	100.0	100.0
32.8	97.6	98.6
49.2	93.8	96.4
65.6	89.9	94.1
82.0	86.1	91.9
15,000 Btu/h Indoor Unit Models		
25.0	100.0	100.0
32.8	97.2	98.2
49.2	93.0	95.4
65.6	88.8	92.6
82.0	84.6	89.8
18,000 Btu/h Indoor Unit Models		
25.0	100.0	100.0
32.8	98.6	99.6
49.2	96.4	99.0
65.6	94.1	98.3
82.0	91.9	97.7
24,000 Btu/h Indoor Unit Models		
25.0	100.0	100.0
32.8	98.2	99.2
49.2	95.4	98.0
65.6	92.4	96.6
82.0	89.6	95.4

Table 115: Multi F MAX Outdoor Unit to Branch Distribution Unit Refrigerant Line Length Derates.

Main Piping Length (feet)	16.4	32.8	49.2	65.6	82.0	98.4	114.8	131.2	147.6	164.0	180.4
Cooling Capacity (%)	100.0	98.8	97.3	95.8	94.3	92.8	91.3	89.8	88.3	86.8	85.3
Heating Capacity (%)	100.0	99.6	99.2	98.7	98.3	97.8	97.4	96.9	96.5	96.0	95.6

Figure 253: Multi F MAX Outdoor Unit to Branch Distribution Unit Refrigerant Line Length Derate Chart.

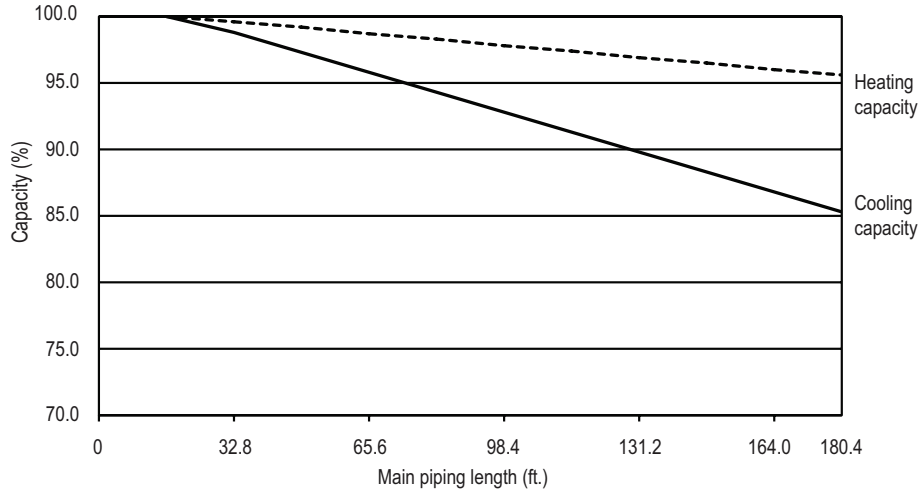

Table 116: Multi F MAX Branch Distribution Unit to Indoor Unit Refrigerant Line Length Derates.

Piping Length (feet)	Cooling Capacity (%)	Heating Capacity (%)
7,000 Btu/h Indoor Unit Models		
16.4	100.0	100.0
32.8	98.0	99.5
49.2	96.0	98.9
9,000 Btu/h Indoor Unit Models		
16.4	100.0	100.0
32.8	97.5	98.8
49.2	95.0	97.5
12,000 Btu/h Indoor Unit Models		
16.4	100.0	100.0
32.8	97.0	98.3
49.2	94.0	96.5
15,000 Btu/h Indoor Unit Models		
16.4	100.0	100.0
32.8	97.2	98.2
49.2	93.0	95.4
18,000 Btu/h Indoor Unit Models		
16.4	100.0	100.0
32.8	98.3	99.5
49.2	96.5	99.0
24,000 Btu/h Indoor Unit Models		
16.4	100.0	100.0
32.8	97.8	99.2
49.2	95.5	98.4
36,000 Btu/h Indoor Unit Models		
16.4	100.0	100.0
32.8	97.9	98.8
49.2	95.7	97.6

Altitude Correction Factor

The impact of air density must be considered on systems installed at a significant altitude above sea level, therefore, locally accepted altitude correction factors must be applied.

Defrost Correction Factor for Heating Operation

The outdoor unit heating capacity may need to be adjusted for frost accumulation on air-cooled systems. If design day conditions are below the dewpoint of the surrounding air, frost may not be a problem and no correction factor is needed. In certain weather conditions, however, frost may form and accumulate on the air-cooled outdoor unit coil and impact the coils ability to transfer heat. If significant frost accumulates on the outdoor unit coil, a defrost algorithm will start automatically. The timing between defrost periods is determined by the system's ability to achieve a target head pressure value.

Capacity and AHRI ratings tables do not factor in capacity reduction when frost has accumulated on the condenser coil, nor during defrost operation.

Integrated heating capacity values can be obtained using the formula:

$$A = B \times C$$

Where:

A = Integrated Heating Capacity.

B = Value found in the Capacity Table.

C = Correction Factor for Frost Accumulation Factor (from Table 101).

Table 117: Outdoor Unit Frost Accumulation Factor (Heating)¹.

Entering DB (°F)	19.4	23.0	26.6	32.0	37.4	41.0	44.6
Derate factor	0.98	0.95	0.93	0.86	0.93	0.96	1.0

¹At 85% outdoor air relative humidity.

The frost accumulation factor does not account for effects of snow accumulation restricting airflow through the outdoor unit coil.

Note:

There will be temporary reduction in capacity when frost / ice accumulates on the outside surface of the outdoor unit heat exchanger. The level of capacity reduction depends on a number of factors, for example, outdoor temperature (°F DB), relative humidity (RH), and the amount of frost present.

Check the Indoor and Outdoor Unit Selection(s)

Compare the corrected cooling and heating capacities to the load calculations. Is each capacity sufficient for the zone it serves?

For each indoor unit, the corrected capacity must be at least equal to the total of the cooling design load (plus ventilation load, if applicable) for the space(s) served by the indoor unit. For each indoor unit, the corrected capacity also must be at least equal to the total of the heating design load (plus ventilation load, if applicable) for the space(s) and / or thermal zones served by the indoor unit.

The outdoor unit selected should be large enough to offset the total cooling load for all spaces it serves (account for ventilation air cooling load if the ventilation air has not been pretreated to room neutral conditions). The outdoor unit should also be large enough to offset the total heating load for all spaces it serves.

If the corrected heating capacity ratio exceeds 100%, reselect the equipment, or change the system design by moving some of the load to another system.

System Sizing Check Formulas

1. Outdoor Unit Rated Capacity.

$Q_{odu(rated)}$ (From capacity tables).

2. Outdoor Unit Capacity at T_i , T_o Temperature.

$Q_{odu(T_i, T_o)}$ (From capacity tables).

3. Outdoor Unit Capacity Coefficient Factor.

$$F_{(T_i, T_o)} = Q_{odu(T_i, T_o)} / Q_{odu(rated)}$$

4. Piping Correction Factor (From Capacity Coefficient Factor Tables).

$F_{(length)}$ for each piping length

5. Individual Indoor Unit Combination Capacity.

$$Q_{idu(combi)} = Q_{odu(rated)} \times Q_{idu(rated)} / Q_{idu(rated-total)}$$

6. Individual Indoor Unit Actual Capacity.

$$Q_{idu(actual)} = Q_{odu(combi)} \times F_{(T_i, T_o)} \times F_{(length, altitude)}$$

Conclusions and Recommendations

- Understand the design safety factors.
- Reference load calculations for actual cooling and heating capacities (applies in 99% of applications – consider total load when latent load is greater than 30%).
- Verify that the sensible load of the zone is satisfied.
- Use caution when sizing to meet listed capacity specifications for the scheduled manufacturer's equipment.

If further system design assistance is needed, or you have a unique application you would like to discuss, contact your LG sales rep.

Selecting the Best Location for the Indoor Units

Note:

Select a location for installing the indoor units that will meet the following conditions:

- Indoor Units (IDUs) should not be placed in an environment where the IDUs may be exposed to harmful volatile organic compounds (VOCs) or in environments where there is improper air make up or supply or inadequate ventilation. If there are concerns about VOCs in the environment where the IDUs are installed, proper air make up or supply and/ or adequate ventilation should be provided. Additionally, in buildings where IDUs will be exposed to VOCs consider a factory-applied epoxy coating to the fan coils for each IDU.
- Within allowable parameters for proper connection to the outdoor unit (or Branch Distribution unit, if a Multi F MAX system).
- So that condensation drainage can be conveniently routed away.
- Include enough space around the indoor unit so that it is accessible for maintenance and service purposes.
- Where electrical noise / electromagnetic waves will not affect indoor unit operation. Maintain proper distances between the indoor units and electric wires, audio and visual appliances, breaker / circuit panels, etc. If the frequency signal of the appliance is unstable, then install the indoor unit a minimum of ten (10) feet away, and run the power and transmission cables through a conduit.
- An area that is level and with enough strength to bear the weight of the indoor unit(s).
- No obstacles to air circulation around the unit; keep proper distances from ceilings, doorways, floor, walls, etc.
- An area where operation sound won't disturb occupants.
- An area that does not expose the indoor unit(s) to heat, water, steam, oil splattering or spray.

Selecting the Best Location for the Branch Distribution (BD) Unit

Note:

Branch Distribution (BD) units are used only with Multi F MAX systems to distribute the refrigerant from the outdoor unit to up to eight indoor units. Select location indoors that will meet the following conditions:

- Within allowable parameters for proper connection to the Multi F MAX outdoor unit and indoor unit(s); refrigerant piping and wire lengths must not exceed amounts specified by LG Electronics, U.S.A., Inc.
- Condensate drain piping is not required.
- Ensure there is enough space in the installation area for service purposes; install the refrigerant piping and electrical wiring system in an easily accessible location.
- Level where there is enough strength to bear the weight of the BD unit.
- Ⓞ Do not install the BD unit in a location where it would be subjected to strong radiation heat from heat sources.
- Avoid an installation environment where the BD unit would be exposed to heat, water, steam, oil splattering or spray.
- Install the unit in a location where any sound it generates will not disturb occupants in the surrounding rooms.
- No obstacles to air circulation around the unit; keep proper distances from ceilings, doorways, floor, walls, etc.
- Where high-frequency electrical noise / electromagnetic waves will not affect operation. Maintain proper distances between the BD unit(s) and electric wires, audio and visual appliances, breaker / circuit panels, etc.

Selecting the Best Location for the Outdoor Unit

⚠ DANGER

To avoid the possibility of fire, do not install the unit in an area where combustible gas may generate, flow, stagnate, or leak. Failure to do so will cause serious bodily injury or death.

⚠ WARNING

Do not install the unit in a location where acidic solution and spray (sulfur) are often used as this may cause serious bodily injury or death. Do not use the unit in environments where oil, steam, or sulfuric gas are present as this may cause serious bodily injury or death.

⚠ CAUTION

When deciding on a location to place the outdoor unit, be sure to choose an area where run-off from defrost will not accumulate and freeze on sidewalks or driveways which may create unsafe conditions.

Note:

Select a location for installing the outdoor unit that will meet the following general conditions:

- A location strong enough to bear the weight of the outdoor unit.
- A location that allows for optimum air flow and is easily accessible for inspection, maintenance, and service.

Selecting the Best Location for the Outdoor Unit, continued.

- Where piping between the outdoor unit, indoor unit(s), and BD units (Multi F MAX systems only) are within allowable limits.
- Include space for drainage to ensure condensate flows properly out of the unit when it is in heating mode. Avoid placing the outdoor unit in a low-lying area where water could accumulate.



- Where it will not be subjected to direct thermal radiation from other heat sources, nor an area that would not expose the outdoor unit to heat or steam like discharge from boiler stacks, chimneys, steam relief ports, other air conditioning units, kitchen vents, plumbing vents, and other sources of extreme temperatures.
- Where high-frequency electrical noise / electromagnetic waves will not affect operation.
- Where operating sound from the unit will not disturb inhabitants of surrounding buildings.
- Where the unit will not be exposed to direct, strong winds.

Rooftop Installations

If the outdoor unit is installed on a roof structure, be sure to level the unit. Ensure the roof structure and anchoring method are adequate for the unit location. Consult local codes regarding rooftop mounting.

Oceanside Installation Precautions

- Install the outdoor unit on the side of the building opposite from direct ocean winds.
- Select a location with good drainage.
- Periodically clean dust or salt particles off of the heat exchanger with water.



- Avoid installing the outdoor unit where it would be directly exposed to ocean winds.

Note:

Ocean winds may cause corrosion, particularly on the condenser and evaporator fins, which, in turn could cause product malfunction or inefficient performance.

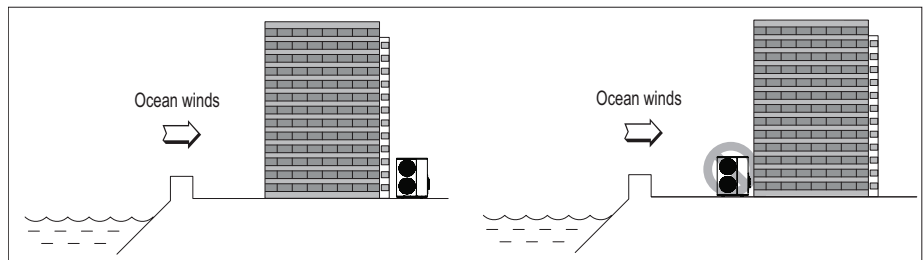

Note:

Additional anti-corrosion treatment may need to be applied to the outdoor unit at oceanside locations.

If the outdoor unit must be placed in a location where it would be subjected to direct ocean winds, install a concrete windbreaker strong enough to block any winds. Windbreaker height and width should be more than 150% of the outdoor unit, and be installed at least 27-1/2 inches away from the outdoor unit to allow for airflow.

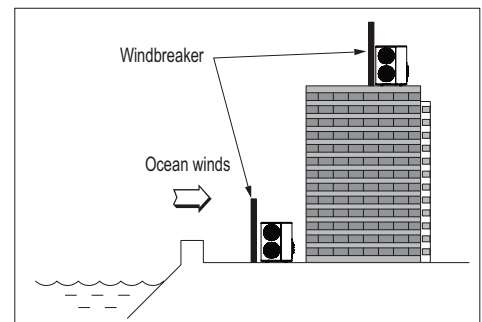

Planning for Snow and Ice

In climates that experience snow buildup, place the unit on a raised platform to ensure proper condenser airflow. The raised support platform must be high enough to allow the unit to remain above possible snow drifts. Mount the unit on a field-provided stand that is higher than the maximum anticipated snowfall for the location. Design the mounting base to prevent snow accumulation on the platform in front or back of the unit case. If necessary, provide a field fabricated hood to keep snow and ice and/or drifting snow from accumulating on the coil surfaces. Use inlet and discharge duct or hoods to prevent snow or rain from accumulating on the fan inlet and outlet guards. Best practice prevents snow from accumulating on top of the unit. Consider tie-down requirements in case of high winds or where required by local codes.

Outdoor Unit Platform Requirements

Figure 254: Outdoor Unit Foundation Requirements.

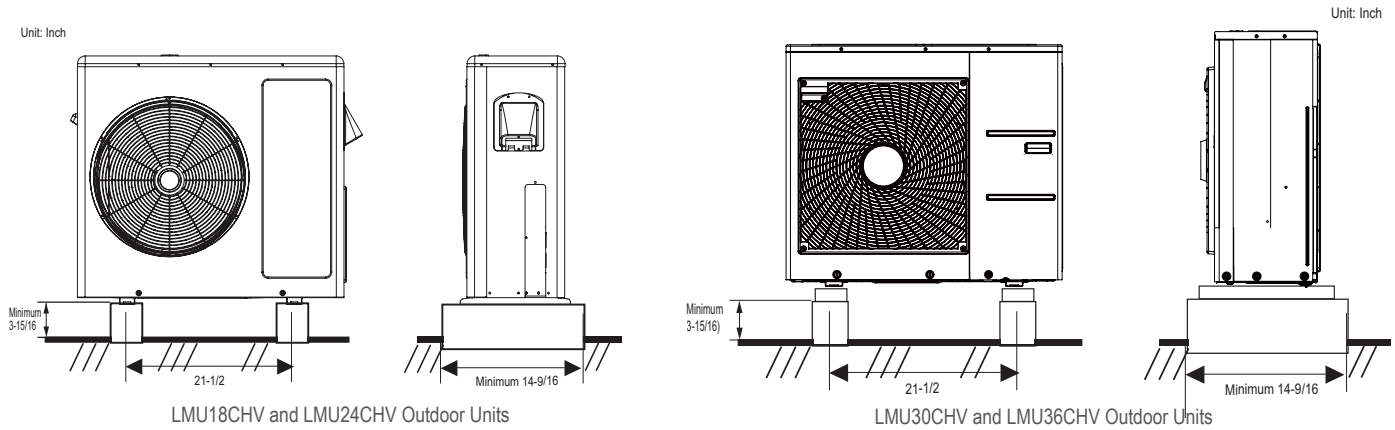
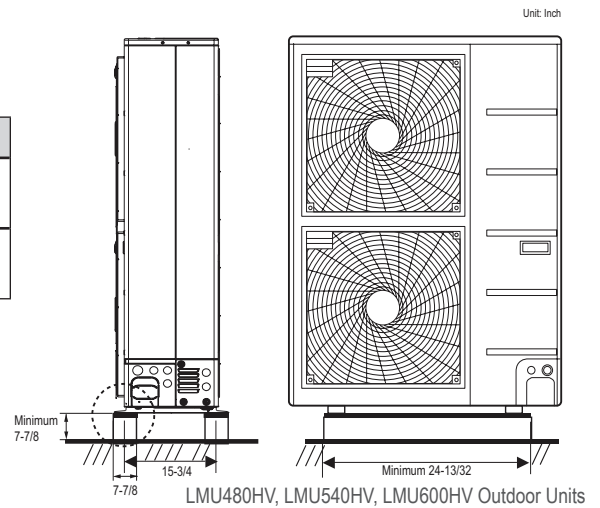

Table 118: Outdoor Unit Foundation Specifications.

Outdoor Unit Type	Bolt Type	Concrete Height	Bolt Depth
LMU18CHV, LMU24CHV, LMU30CHV, LMU36CHV	M10-J	Minimum 3-15/16 inches	Minimum 2-3/4 inches
LMU480HV, LMU540HV, LMU600HV	M10-J	Minimum 7-7/8 inches	Minimum 2-3/4 inches



Bolting the Outdoor Unit to the Platform

1. Ensure that the concrete platform will not degrade easily, and has enough strength to bear the weight of the unit.
2. Include an H-beam support. Firmly attach the corners, otherwise the support will bend.
3. Use a hexagon nut.
4. Use anti-vibration material.
5. Include enough space around the concrete foundation for condensate drainage.
6. Seal all wiring and piping access holes to prevent bugs from entering the unit.

Concrete Platform Specifications

- Concrete foundations should be made of one part cement, two parts sand, and four parts gravel.
- The surface of the foundation should be finished with mortar with rounded edges, and weatherproofed.

Figure 255: Bolting the Outdoor Unit to the Platform.

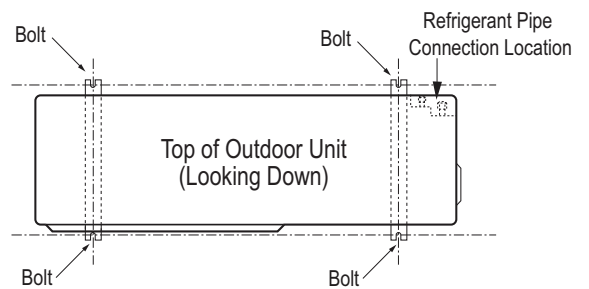
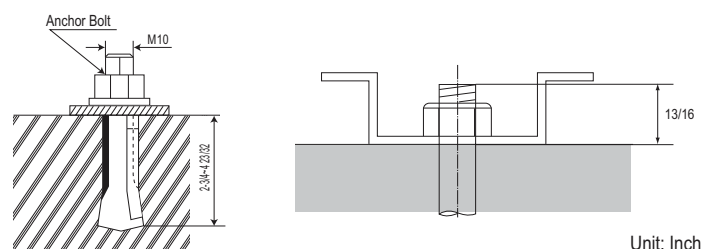

Figure 256: Close up of Bolt Attachment.



Unit: Inch

Tie-Downs and Lightning Protection

Tie-Downs

- The strength of the roof must be checked before installing the outdoor units.
- If the installation site is prone to high winds or earthquakes, when installing on the wall or roof, securely anchor the mounting base using a field-provided tie-down configuration approved by a local professional engineer.
- The overall tie-down configuration must be approved by a local professional engineer. Always refer to local code when using a wind restraint system.

Lightening Protection

- To protect the outdoor unit from lightning, it should be placed within the specified lightning safety zone.

Table 119: Safety Zone Specifications.

Building Height (feet)	66	98	148	197
Protection Angle (°)	55	45	35	25

- Power cable and communication cable should be installed five (5) feet away from lightning rod.
- A high-resistance ground system should be included to protect against induced lightning or indirect strike.

Outdoor Unit Service Access and Allowable Clearances

Appropriate airflow through the outdoor unit coil is critical for proper unit operation.

- Include enough space for airflow and for service access. If installing multiple outdoor units, avoid placing the units where the discharge of one unit will blow into the inlet side of an adjacent unit.
- If an awning is built over the unit to prevent direct sunlight or rain exposure, make sure that the discharge air of the outdoor unit isn't restricted.



- No obstacles to air circulation around the unit; keep proper distances from ceilings, fences, floor, walls, etc. (Install a fence to prevent pests from damaging the unit or unauthorized individuals from accessing it.)

When installing the outdoor unit, consider service, inlet, and outlet, and minimum allowable space requirements as illustrated in the following diagrams.

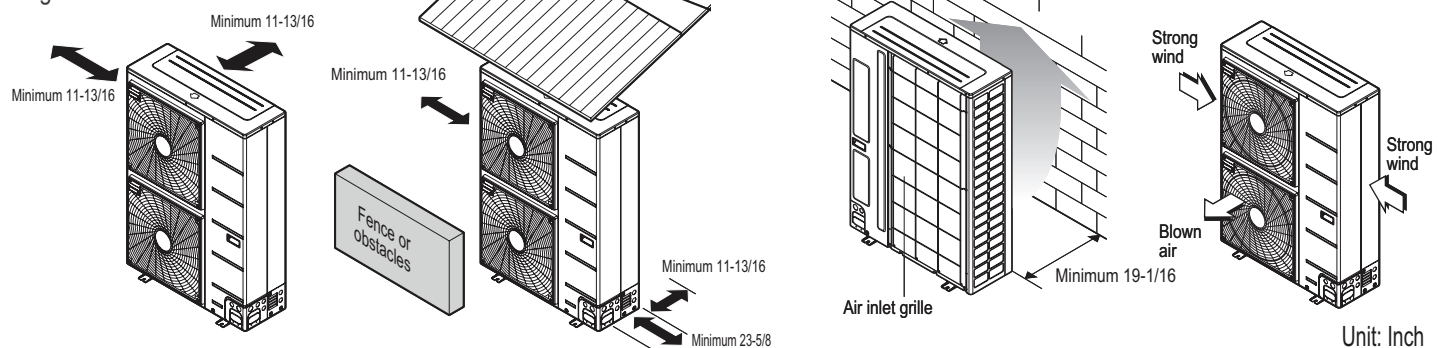

Ensure that the space at the back of the outdoor unit is a minimum of 11-13/16 inches, and include a minimum of 23-5/8 inches at the right side of the unit for service.

Figure 257: Lightning Protection Diagram.

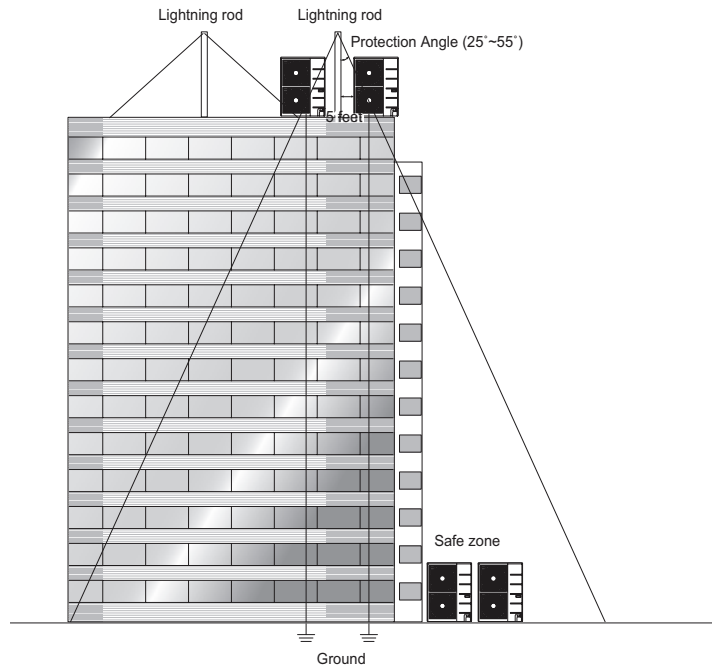

Note:

If the building does not include lightning protection, the outdoor unit may be damaged from a lightning strike. Inform the customer of this possibility in advance.

Clearance Requirements when Different Obstacles are Present (Unit: Inch).

Obstacle on the suction side only.

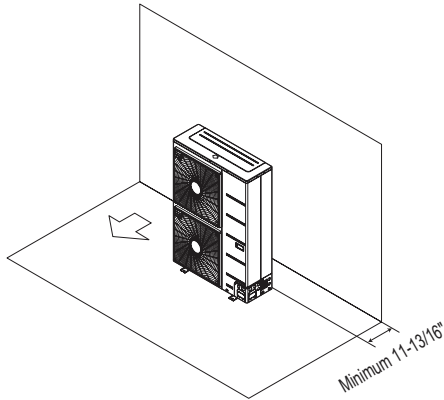

Obstacles on the suction side and on both left and right sides.

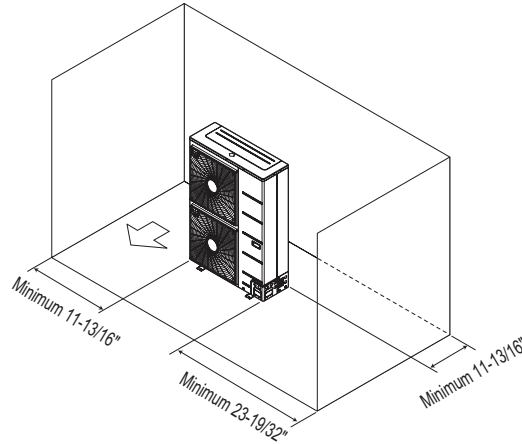

Obstacles above and on the air intake side.

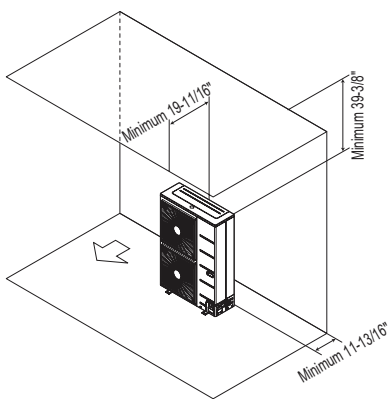

Obstacles above, on the air intake side, and on both left and right sides

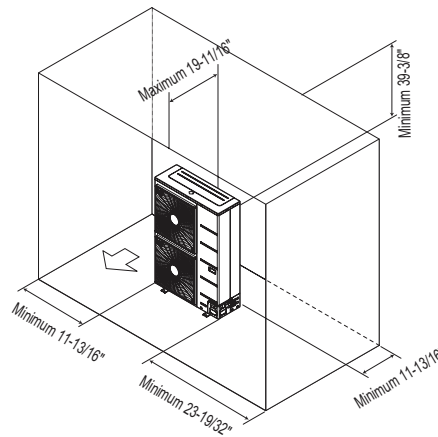

Obstacle just on the air discharge side.

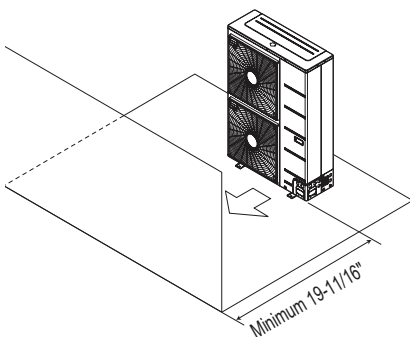

Obstacles above and on the air discharge side.

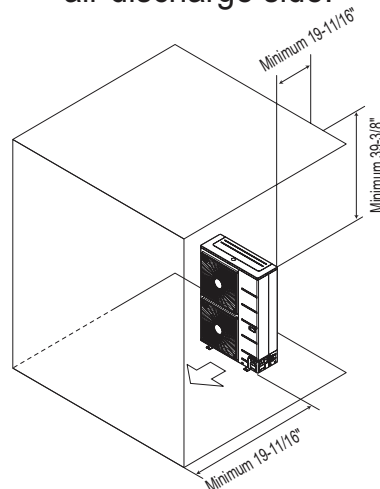

PLACEMENT CONSIDERATIONS

MULTI F
MULTI F MAX

Clearance Requirements when Different Obstacles are Present, continued. (Unit: Inch)

Where there are obstacles on both suction and discharge sides (discharge side obstacle is higher than the outdoor unit).

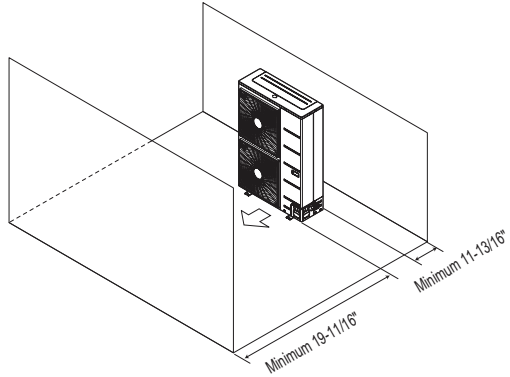

Where there are obstacles above, and on both suction and discharge sides (discharge side obstacle is higher than the outdoor unit).

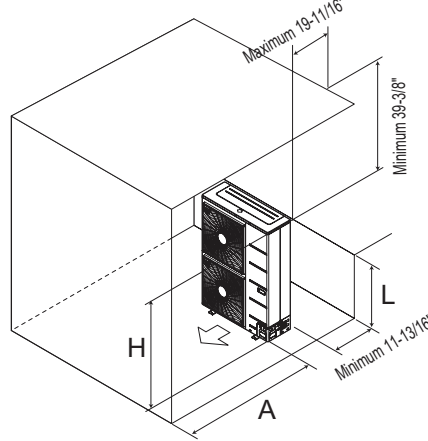
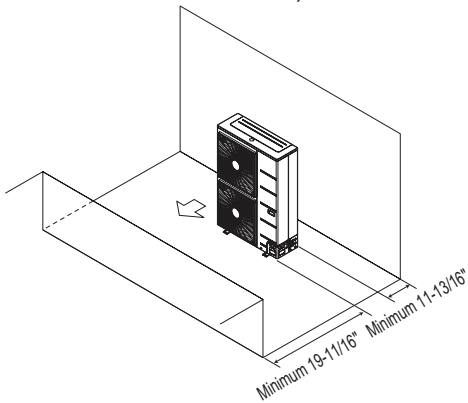

Table 120: Ratio among H, A, and L.

	L	A
L ≤ H	0 < L ≤ 1/2 H	29-1/32 inches
	1/2 H < L	39-3/8 inches
H < L	Set Stand as: L ≤ H	

If a stand is necessary, it should be contained (not open frame) to prevent the discharge air from short cycling.

Where there are obstacles on both suction and discharge sides (discharge side obstacle is lower than the outdoor unit).



Where there are obstacles above, and on both suction and discharge sides (discharge side obstacle is lower than the outdoor unit).

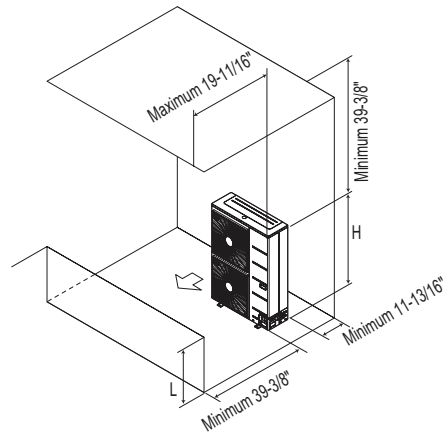

Note:

"L" should be lower than "H". If a stand is necessary, it should be contained (not open frame) to prevent the discharge air from short cycling.

Series installation

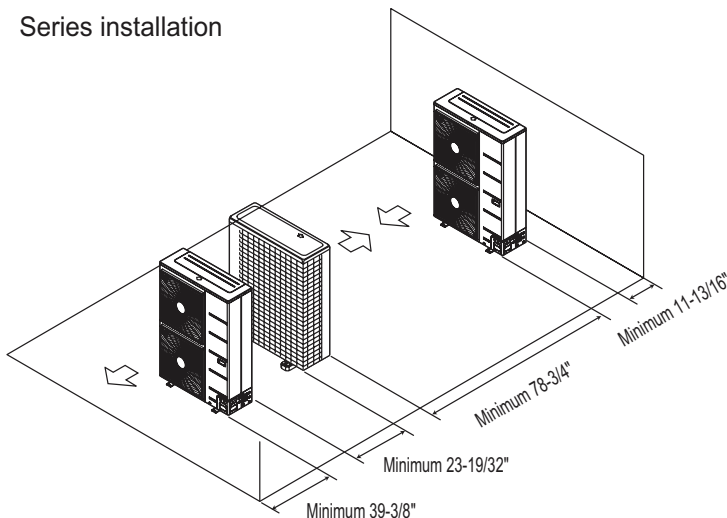

Side-by-side series installation.

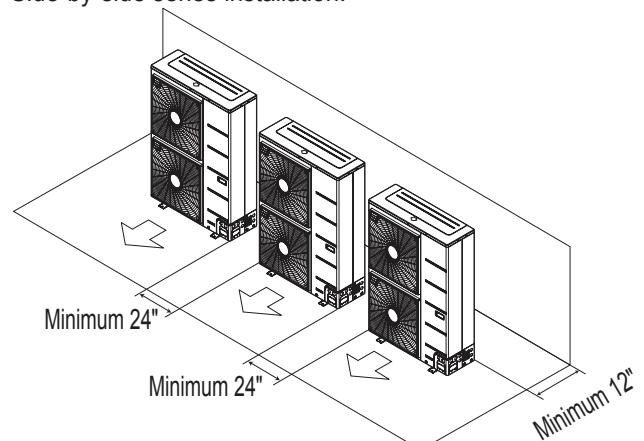

REFRIGERANT PIPING DESIGN & LAYOUT BEST PRACTICES

“Design Guideline Summary” on page 198

“Creating a Balanced System” on page 200

“Condensate Drain Piping” on page 201

REFRIGERANT PIPING DESIGN

MULTI F
MULTI F MAX

Design Guideline Summary

The following are examples of manual pipe size calculations. Designers are highly encouraged to use LATS for Multi F systems.

Device Connection Limitations

- The minimum number of connected and operating indoor units to Multi F / Multi F MAX systems is two, taking into consideration of the minimum combination ratio.
- The maximum number of indoor units for each Multi F / Multi F MAX heat pump systems is:

LMU18CHV = 2 LMU24CHV = 3 LMU30CHV = 4 LMU36CHV = 4 LMU480HV = 8 LMU540HV = 8 LMU600HV = 8

One of the most critical elements of multi-zone systems is the refrigerant piping. The following pages list pipe length limits that must be followed in the design of Multi F and Multi F MAX refrigerant pipe systems:

Using Refrigerant Components

Field-supplied elbows are allowed as long as they are designed for use with R410A refrigerant. The designer, however, should be cautious with the quantity and size of fittings used, and must account for the additional pressure losses in equivalent pipe length calculation for each branch. The equivalent pipe length of each elbow must be added to each pipe segment.

Table 121: Equivalent Piping Length for Elbows, Y-branches, and Branch Distribution Units.

Component	Size (Inches)				
	1/4	3/8	1/2	5/8	3/4
Elbow (ft.)	0.5	0.6	0.7	0.8	1.2
Y-Branch Kit (ft., Multi F MAX systems only) ¹	1.6				
Branch Distribution Unit (ft., Multi F MAX systems only)	8.2				

¹Kit contains two Y-branches: one for liquid and one for vapor.

Multi F System

Example: LMU36CHV outdoor unit with four (4) indoor units connected.

ODU: Outdoor Unit.

IDU: Indoor Unit.

A, B, C, D: Pipes from Outdoor Unit to Indoor Unit.

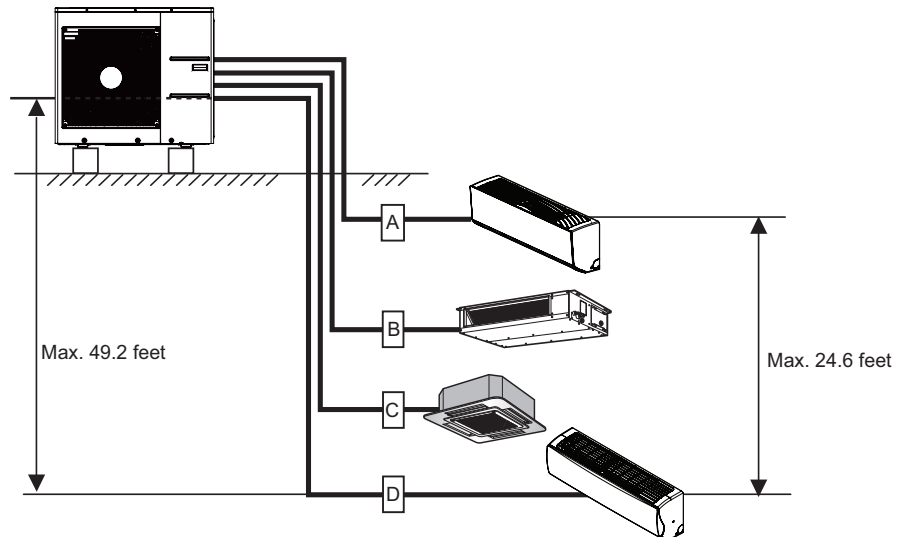

Table 122: Multi F Outdoor Unit Refrigerant Piping System Limitations.

Outdoor Unit	Minimum Length for Each Pipe (ft.)	Maximum Piping Length to Each Indoor Unit (ft.)				Maximum Total Piping Length for Each System (ft.)
		A	B	C	D	
LMU18CHV	10	82	82	-	-	164
LMU24CHV	10	82	82	82	-	246.1
LMU30CHV	10	82	82	82	82	246.1
LMU36CHV	10	82	82	82	82	246.1

The following are examples of manual pipe size calculations. Designers are highly encouraged to use LATS for Multi F systems.

Multi F MAX System with One Branch Distribution Unit

Example: LMU540HV outdoor unit with four (4) indoor units, and one (1) branch distribution unit connected.

ODU: Outdoor Unit.

IDU: Indoor Unit.

BDU: Branch Distribution Unit.

A: Main Pipe.

B: Branch Pipe (Branch Distribution Unit to Indoor Unit[s]).

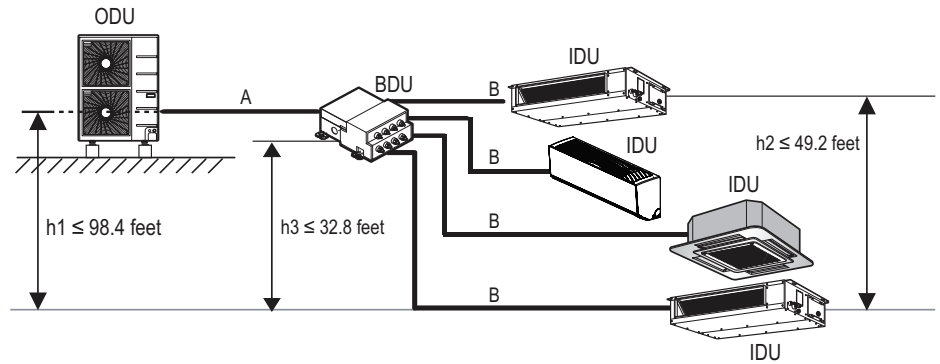

Multi F MAX System with Two Branch Distribution Units

Example: LMU540HV outdoor unit with seven (7) indoor units, and two (2) branch distribution units connected.

ODU: Outdoor Unit.

IDU: Indoor Unit.

BD: Branch Distribution Unit(s).

ΣA : Main Pipe.

ΣB : Branch Pipe (Branch Distribution Unit[s] to Indoor Unit[s]).

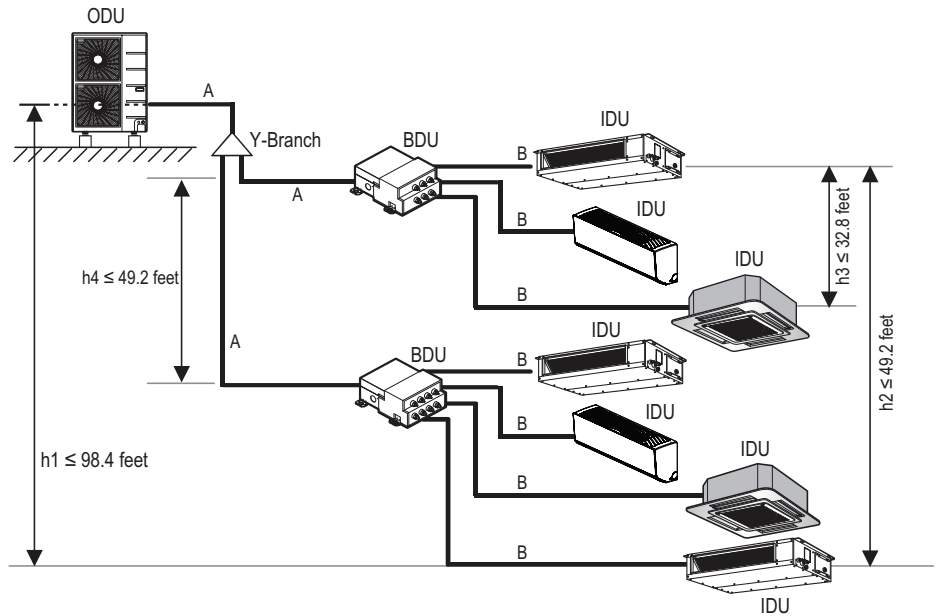

Table 123: Multi F MAX Outdoor Unit Refrigerant Piping System Limitations.

Pipe Length (ELF = Equivalent Length of pipe in Feet)	Total piping length ($\Sigma A + \Sigma B$)		≤475.7 feet
	Main pipe (Outdoor Unit to Branch Distribution Units: ΣA)	Minimum	10 feet
		Maximum	≤180.4 feet
	Total branch piping length (ΣB)		≤295.3 feet
Branch pipe (Branch Distribution Units to Indoor Units: B)	Minimum	10 feet	
	Maximum	≤49.2 feet	
Elevation Differential (All Elevation Limitations are Measured in Actual Feet)	If outdoor unit is above or below indoor unit (h_1)		≤98.4 feet
	Between the farthest two indoor units (h_2)		≤49.2 feet
	Between branch distribution unit and farthest connected indoor unit(s) (h_3)		≤32.8 feet
	Between branch distribution units (h_4)		≤49.2 feet

Table 124: Multi F MAX Piping Sizes.

Piping	Main Pipe A (inch)	Branch Pipe B
Liquid	Ø3/8	Depends on the size of the indoor unit piping
Gas	Ø3/4	

Creating a Balanced / Quality Piping System

Unlike designing duct-work or chilled and hot water pipe systems where balancing dampers, ball valves, orifices, circuit setters, or other flow control devices can be installed to modify or balance the flow of cooling medium, these cannot be used in a Multi F system. Therefore, variable refrigerant flow systems have to be designed to be “self balanced.” Balanced liquid refrigerant distribution is solely dependent on the designer using the correct pipe size for each segment. Pipe sizing considerations include pipe length, pipe segment pressure drop relative to other pipe segments in the system, type and quantity of elbows, bends present, fitting installation orientation, and end use device elevation differences.

Note:

The designer should avoid creating excessive pressure drop. When liquid refrigerant is subjected to excessive pressure drop, liquid refrigerant will change state and “flash” to vapor. Vapor present in a stream of liquid refrigerant before reaching the indoor unit coil (or branch distribution unit for Multi F MAX systems) results in a loss of system control and causes damage to the components. The pipe system must be designed in a manner that avoids the creation of unwanted vapor.

Refrigerant Piping System Verification

To ensure that the refrigerant piping design is suitable for the system, a LATS refrigerant piping design software report must be provided with every Multi F order. Following the installation, if any changes or variations to the design were necessary, an “as-built” LATS piping design software report must be provided to LG prior to system commissioning. User should always check the LATS report actual pipe layout versus pipe limits.

Note:

Any field changes, such as re-routing, shortening or lengthening a pipe segment, adding or eliminating elbows and/or fittings, re-sizing, adding, or eliminating indoor units, changing the mounting height or moving the location of a device or fitting during installation should be done with caution and ALWAYS VERIFIED in LATS MULTI F SOFTWARE before supplies are purchased or installed. Doing so ensures profitable installation, eliminates rework, and ensures easier system commissioning.

Manual Layout Procedure

1. Choose the location of the indoor units on the building drawing.
2. Choose the location of all Y-branch and branch distribution units (if a Multi F MAX system) and note them on the building drawing. Verify that all fittings are positioned per the guideline limitations in “LG Engineered Multi F MAX Y-Branch Kit” on page 217.
3. Plan the route for interconnecting piping. Draw a one-line depiction of the pipe route chosen on the building drawing.
4. Calculate the actual length of each pipe segment and note it on the building drawing.
5. Using the data obtained while selecting the system components, list the corrected cooling capacity next to each indoor unit on the drawing.
6. Starting at the indoor unit located farthest from the outdoor unit, sum the corrected cooling capacity of all indoor units served by the pipe segment for each branch and runout pipe (indoor units and branch distribution units [Multi F MAX systems only]). Record these values next to each segment.
7. Verify the size of the liquid and vapor lines.
8. If a Multi F MAX system, refer to the branch distribution unit information on page 227 and the Y-branch kit information on page 233 to verify the part number of each Y-branch and branch distribution unit based on the connected downstream nominal capacity served.
9. Calculate the equivalent pipe length in feet of each pipe segment. If a Multi F MAX system, Y-branch equivalent lengths should be totaled with the upstream segment only. Use equivalent pipe length data when it is provided with field-purchased fittings. If not available, use the data provided in Table 121 on page 198 to estimate the equivalent length of field-provided pipe and fittings for each segment. Equivalent lengths should be totaled with the upstream segment only.
10. For Multi F systems, verify the equivalent pipe length complies with the limitations in Table 122 on page 198. For Multi F MAX systems, verify the equivalent pipe length complies with the limitations in Table 123 on page 199. If the limitations are exceeded, either reroute the pipe or change the location of the indoor unit, Y-branch fittings and branch distribution units (if Multi F MAX systems), so the design conforms with all limitations.
11. If pipe length is adjusted as described in Step 10 above, verify again if the length of the design complies with the limitations in Table 1220 (Multi F) or Table 1231 (Multi F MAX).
12. Use LATS Multi F software to verify the manually sized pipe design is acceptable. When entering the length of pipe segments in LATS Multi F software, enter the equivalent pipe length. Account for the additional pressure drop created by elbows, valves, and other fittings present in each segment by adding their respective equivalent pipe length to the actual pipe length.

Condensate Drain Piping

Indoor Units

All indoor units generate water during cooling operation, therefore, how to properly handle this condensation must be considered. Some indoor units include factory-installed drain pumps; others apply the gravity drain method.

Table 125: Indoor Unit Drain Piping Specifications.

Indoor Unit	Drain Type	Drain Pipe Diameter (OD / ID, in.)	Drain Amount (gal. / min. at 0.033 ft. height)
Art Cool Wall-Mounted	Gravity	13/16 / 5/8	—
Art Cool Gallery	Gravity	13/16 / 5/8	—
Standard Wall-Mounted	Gravity	13/16 / 5/8	—
Ceiling-Concealed Ducted (Low Static and High Static)	27-1/2 in. Lift Drain Pump, Factory Installed	Ø1-1/4 / Ø1	0.105
Four-Way Ceiling Cassette	27-1/2 in. Lift Drain Pump, Factory Installed	Ø1-1/4 / Ø1	0.105
Vertical-Horizontal Air Handling Unit	Gravity	Ø3/4 / —	—

Figure 258: Diagram of an Indoor Unit with a Gravity Drain.

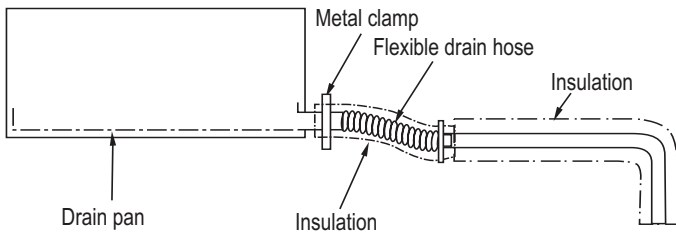
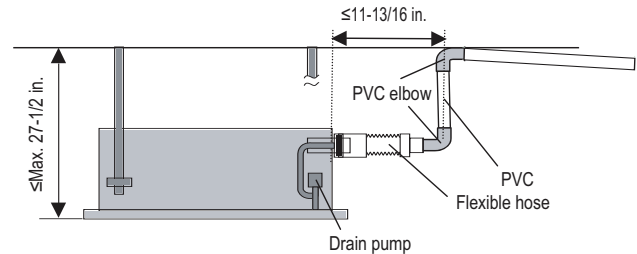

Figure 259: Diagram of an Indoor Unit with a Drain Pump.



ELECTRICAL CONNECTIONS

“General Information” on page 204

**“Power Wiring (208-230V) and Communications Cable
Details” on page 207**

“Remote Controller Connections” on page 212

“Indoor Unit Group Control” on page 213

⚠ WARNING

- All power (line voltage) wiring and communication cable installation must be performed by trained service providers working in accordance with all local, state, and National Electrical Code (NEC) / UL / ETL federal regulations related to electrical equipment and wiring, and following the manufacturer product diagrams, requirements, and instructions in this manual. Electric shock can cause physical injury or death.
- Be sure that main power to the unit is completely off before proceeding. Follow all safety and warning information outlined at the beginning of this manual. Failure to do so may cause electric shock and bodily injury.
- Install a main shutoff switch or circuit breaker that interrupts all power sources simultaneously (circuit breaker should be resistant to electromagnetic currents). Be sure that the circuit breaker or some other emergency power cutoff device is in place before any power wiring is done to the system. Failure to do so may cause bodily injury or death.
- ⓧ Never touch any power lines or live cables before all power is cutoff to the system. To do so may cause bodily injury or death.
- Power wiring and communication cable sizes must comply with all applicable federal, state, and local codes. Undersized wiring may lead to unacceptable voltage at the unit and may cause a fire, which may cause bodily injury or death.
- Properly ground the outdoor unit, indoor units, and branch distribution units. Ground wiring must always be installed by a trained technician. Ground wiring is required to prevent accidental electrical shock during current leakage, which may cause bodily injury or death.
- Verify that the branch switch and circuit breaker are set to OFF before installing the wiring system. Electric shock can cause physical injury or death.
- Install appropriately sized breakers / fuses / overcurrent protection switches and wiring in accordance with local, state, and NEC regulations related to electrical equipment and wiring, and following the instructions in this manual. Generated overcurrent may include some amount of direct current. Using an oversized breaker or fuse may result in electric shock, physical injury or death.
- ⓧ Do not connect ground wire to refrigerant, gas, sewage, or water piping; to lightning rods; to telephone ground wiring; or to the building plumbing system. Failure to properly provide a NEC-approved earth ground can result in electric shock, fire, physical injury or death.

Note:

- Consider ambient conditions (temperature, direct sunlight, inclement weather, etc.) when selecting, installing, and connecting the power wiring.
- Properly ground the outdoor unit, indoor units, and branch distribution units. Ground wiring must always be installed by a trained technician. Improperly grounded wire can cause communication problems from electrical noise, and motor current leakage.
- Install appropriately sized breakers / fuses / overcurrent protection switches and wiring in accordance with local, state, and NEC regulations related to electrical equipment and wiring, and following the instructions in this manual. Generated overcurrent may include some amount of direct current. Using an oversized breaker or fuse may result in equipment malfunction and property damage.
- ⓧ Do not connect ground wire to refrigerant, gas, or water piping; to lightning rods; to telephone ground wiring; or to the building plumbing system. Failure to properly provide a NEC-approved earth ground can result in property damage and equipment malfunction.
- ⓧ Do not operate the air conditioning system until the refrigerant piping installation is complete. Operating the system before refrigerant piping is finalized may damage the compressor.

Power Supply / Power Wiring Specifications

- Multi F systems operate at 1Ø, 208-230V, 60Hz, and power is wired to the outdoor unit only. The outdoor unit will supply power to the indoor units and the branch distribution units (Multi F MAX systems only) through the communication / connection (power) cable.
- Power supply to the outdoor unit should be selected based on NEC and local codes. Maximum allowable voltage fluctuation $\pm 10\%$ or nameplate rated value.
- Power wiring to the outdoor unit(s) should be solid or stranded, and must comply with all local and national electrical codes.
- Properly ground the outdoor unit and indoor unit per NEC and local codes.
- Ground wire should be longer than the common power / communication wires.
- Connect the wiring firmly so the wires cannot be easily pulled out.
- Refer to the inside of the chassis cover or control cover for circuit and terminal block diagrams.
- Always match color codes of each wire and follow wiring diagram.
- ⚠ Do not install power wiring to the outdoor unit and the communication / connection (power) cable to the indoor unit in the same conduit. Use separate conduits.

Figure 260: Multi F / Multi F MAX Outdoor Unit Power Wiring.

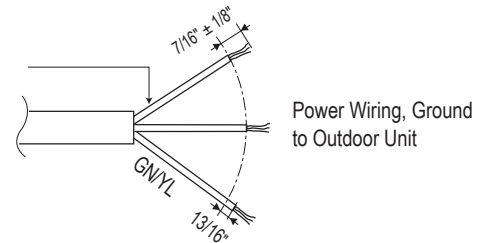

⚠ WARNING

Always have a trained service provider properly ground the outdoor unit. If the outdoor unit is not properly grounded, there is a risk of electric shock, physical injury, or death.

Communication / Connection (Power) Cable Specifications

- Multi F Systems:
 - All communication / connection (power) cable from the outdoor unit to the indoor unit to be minimum 18 AWG, four (4) conductor, stranded, shielded or unshielded (if shielded, it must be grounded to the chassis of the outdoor unit only), and must comply with applicable local and national codes.
- Multi F MAX Systems:
 - All communication / connection (power) cable from the outdoor unit to the branch distribution unit(s) to be minimum 16 AWG, four (4) conductor, stranded, shielded or unshielded (if shielded, it must be grounded to the chassis of the outdoor unit only), and must comply with applicable local and national codes.
 - All communication / connection (power) cable from the branch distribution unit(s) to the indoor units to be minimum 18 AWG, four (4) conductor, stranded, shielded or unshielded (if shielded, it must be grounded to the chassis of the outdoor unit only), and must comply with applicable local and national codes.
- Insulation material as required by local code.
- Rated for continuous exposure of temperatures up to 140°F.
- Firmly attach the cable; provide slack but secure in a way to prevent external forces from being imparted on the terminal block.
- Wiring should be completed without splices.

Figure 261: Multi F / Multi F MAX Outdoor and Indoor / Branch Distribution Unit Wiring and Communications Cable Diagram.

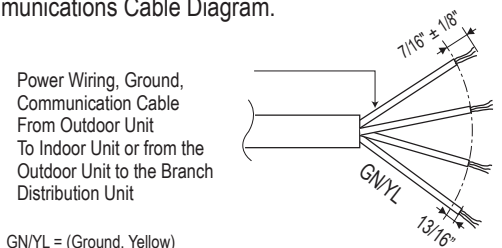

GN/YL = (Ground, Yellow)

Note:

- Use a conduit for the communications / connection (power) cable from the outdoor unit to the indoor units and branch distribution unit(s). Electrical interference may cause product malfunction.
- The communications / connection (power) cable from the outdoor unit to the indoor units / branch distribution unit(s) should be separated and isolated from power wiring to the outdoor unit, computers, radio and television broadcasting facilities, as well as medical imaging equipment. Electrical interference may cause product malfunction.

ELECTRICAL CONNECTIONS

General Information

MULTI F
MULTI F MAX

Figure 262: Multi F System General Power / Communications System Schematic.

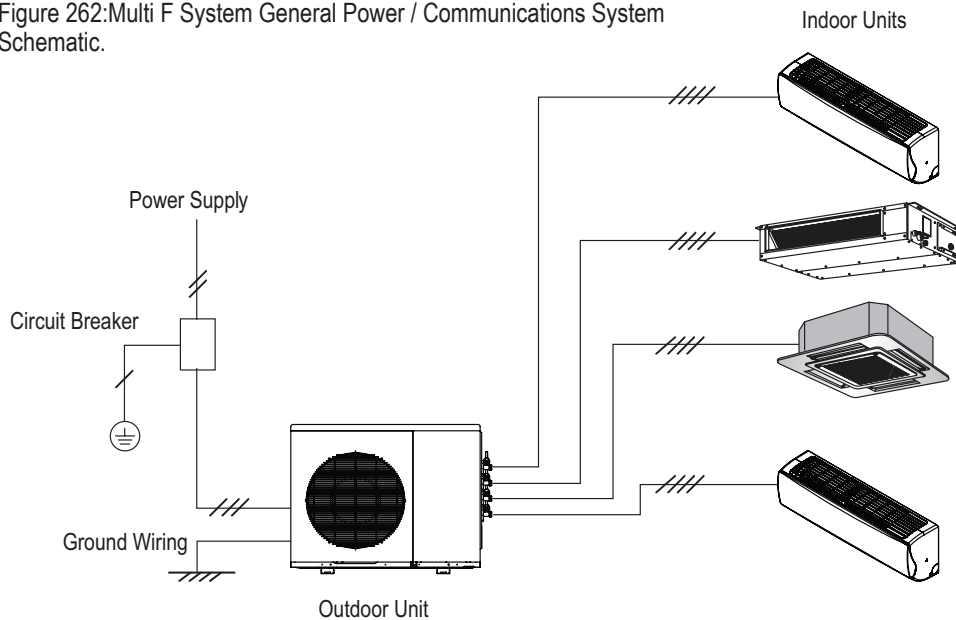
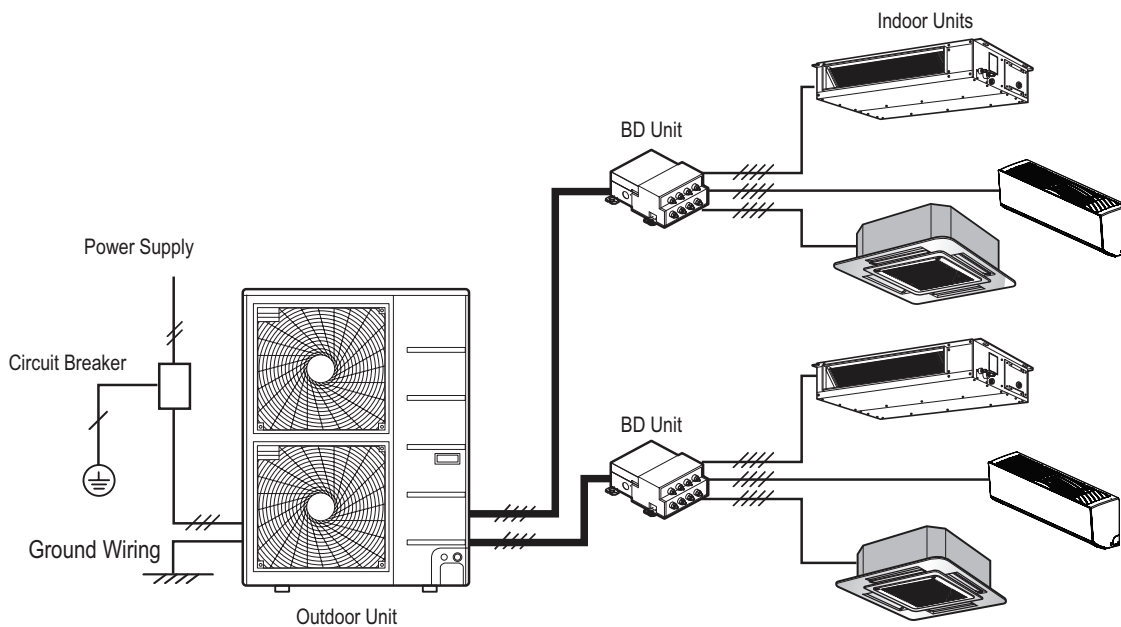

Figure 263: Multi F MAX System General Power / Communications System Schematic.



Note:

- Secure the separate wires in the control box panel using zip ties.
- Secure wiring with accessory clamps so that it does not touch piping.
- Use a conduit for the cable.
- Outside the unit, make sure the communications cable / power wiring are separately shielded, otherwise, the outdoor unit operation may be affected by electrical noise and will malfunction or fail.
- For details on the Multi F with LG RED and Multi F MAX with LG RED units, refer to the engineering manuals on www.lg-dfs.com.

Figure 264: Multi F LMU18CHV System Power Wiring and Communications Cable.

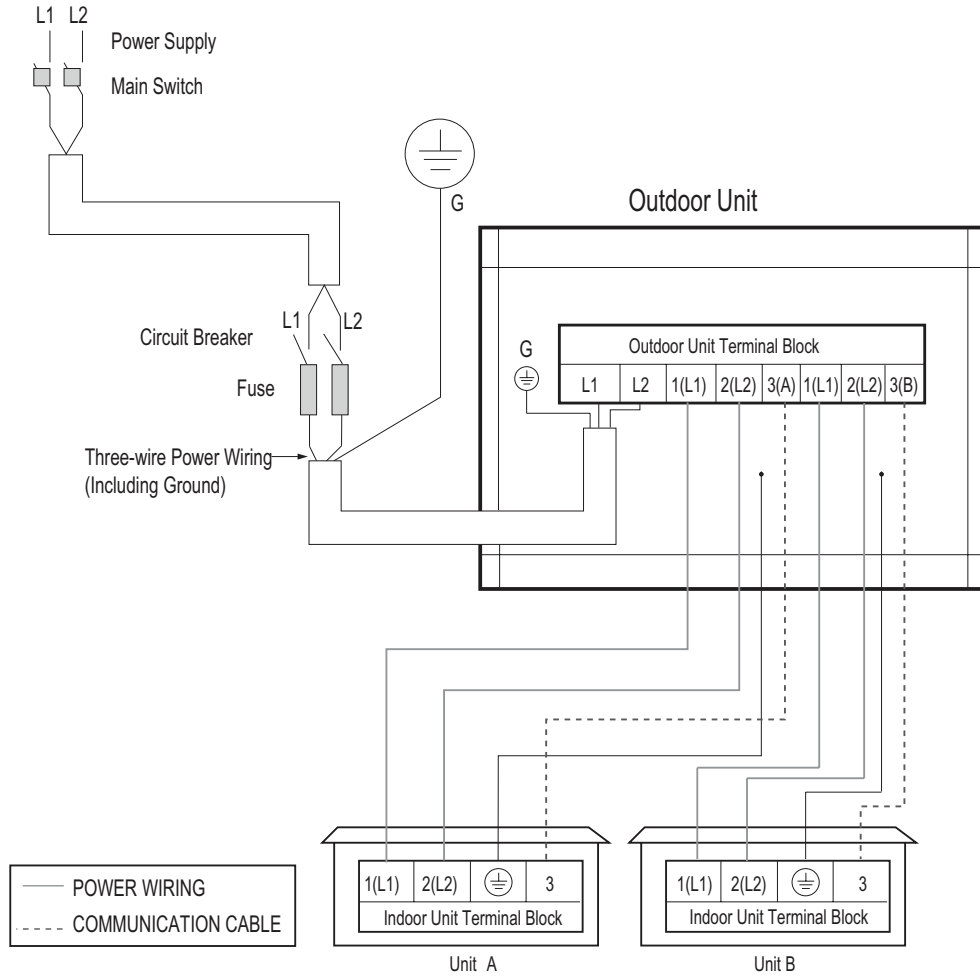

⚠ WARNING

- All field-supplied wiring, components, and materials should follow national, state, and local codes and requirements. Electric shock can cause physical injury or death.
- Use only stranded, shielded or unshielded copper communications / power wiring from the outdoor unit to the indoor units. If shielded, wiring must be grounded to the chassis at the outdoor unit only. Improper wiring may result in fire, electric shock, physical injury or death.
- Ground wiring is required to prevent accidental electrical shock during current leakage, communication problems from electrical noise, and motor current leakage. Do not connect the ground line to the pipes. Improper wiring may result in fire, electric shock, physical injury or death.
- Install a main shutoff switch or circuit breaker that interrupts all power sources simultaneously. Electric shock can cause physical injury or death.
- Wiring cable size must comply with applicable national, state, and local codes. Improper wiring may result in fire, electric shock, physical injury or death.

Note:

- For Multi F with LGRED, refer to Multi F & Multi F MAX with LGRED ODU engineering manual.
- Ground wiring is required to prevent communication problems from electrical noise, and motor current leakage. Failure to provide proper ground wiring can result in property damage and equipment malfunction.
- All field-supplied wiring, components, and materials should follow national, state, and local codes and requirements. Failure to install proper electrical components can result in property damage and equipment malfunction.
- Use only stranded, shielded or unshielded copper communications / power wiring from the outdoor unit to the indoor units. If shielded, wiring must be grounded to the chassis at the outdoor unit only. Failure to install proper wiring can result in property damage and equipment malfunction.
- Install a main shutoff switch or circuit breaker that interrupts all power sources simultaneously. Failure to install proper electric components can result in property damage and equipment malfunction.
- Wiring cable size must comply with applicable national, state, and local codes. Improper wiring can result in property damage and equipment malfunction.

ELECTRICAL CONNECTIONS

Power Wiring (208-230V) and Communications Cable Details

MULTI F
MULTI F MAX

Figure 265: Multi F LMU24CHV System Power Wiring and Communications Cable.

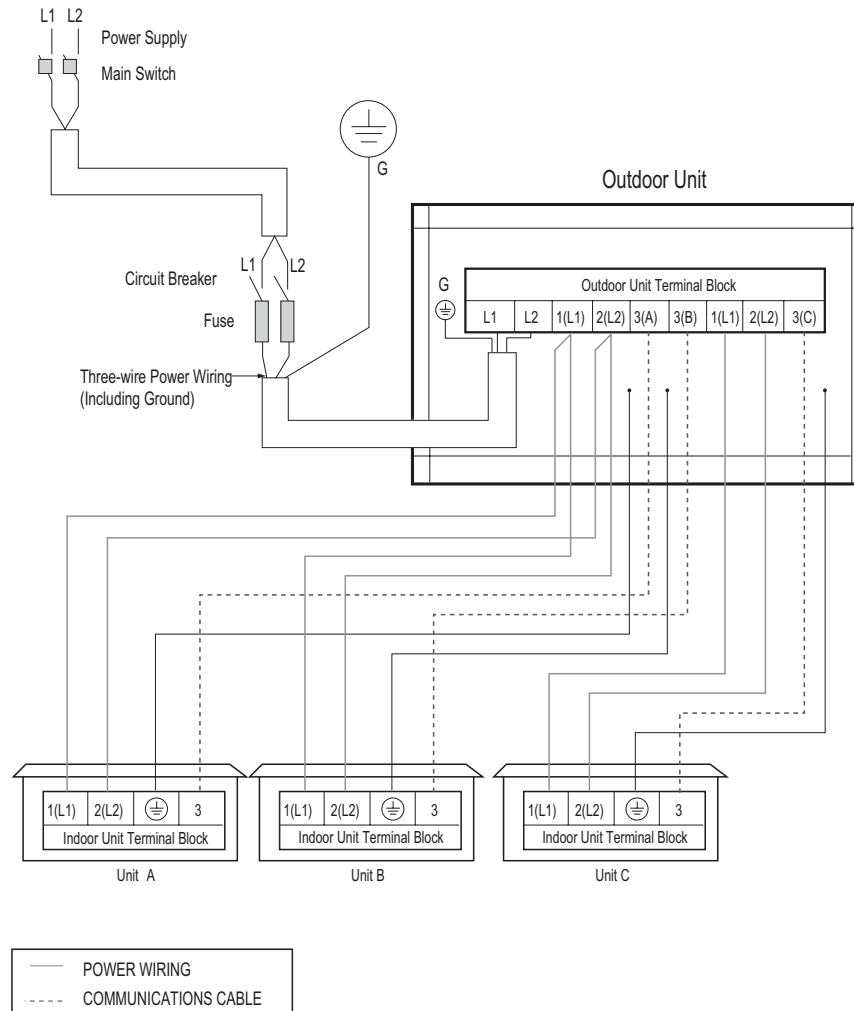

⚠ WARNING

- All field-supplied wiring, components, and materials should follow national, state, and local codes and requirements. Electric shock can cause physical injury or death.
- Use only stranded, shielded or unshielded copper communications / power wiring from the outdoor unit to the indoor units. If shielded, wiring must be grounded to the chassis at the outdoor unit only. Improper wiring may result in fire, electric shock, physical injury or death.
- Ground wiring is required to prevent accidental electrical shock during current leakage, communication problems from electrical noise, and motor current leakage. Do not connect the ground line to the pipes. Improper wiring may result in fire, electric shock, physical injury or death.
- Install a main shutoff switch or circuit breaker that interrupts all power sources simultaneously. Electric shock can cause physical injury or death.
- Wiring cable size must comply with applicable national, state, and local codes. Improper wiring may result in fire, electric shock, physical injury or death.

Note:

- For Multi F with LGRED, refer to Multi F & Multi F MAX with LGRED ODU engineering manual.
- Ground wiring is required to prevent communication problems from electrical noise, and motor current leakage. Failure to provide proper ground wiring can result in property damage and equipment malfunction.
- All field-supplied wiring, components, and materials should follow national, state, and local codes and requirements. Failure to install proper electrical components can result in property damage and equipment malfunction.
- Use only stranded, shielded or unshielded copper communications / power wiring from the outdoor unit to the indoor units. If shielded, wiring must be grounded to the chassis at the outdoor unit only. Failure to install proper wiring can result in property damage and equipment malfunction.
- Install a main shutoff switch or circuit breaker that interrupts all power sources simultaneously. Failure to install proper electric components can result in property damage and equipment malfunction.
- Wiring cable size must comply with applicable national, state, and local codes. Improper wiring can result in property damage and equipment malfunction.

Figure 266: Multi F LMU30CHV and LMU36CHV System Power Wiring and Communications Cable.

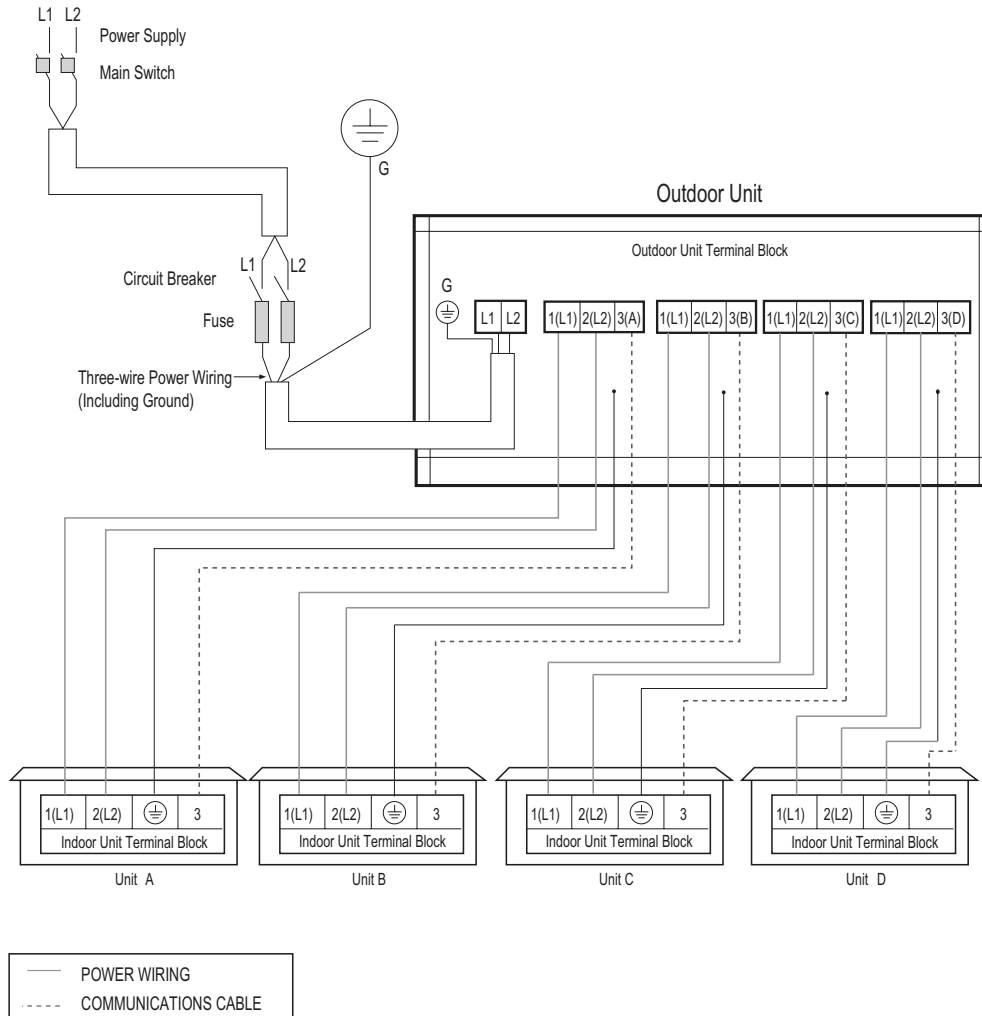

⚠ WARNING

- All field-supplied wiring, components, and materials should follow national, state, and local codes and requirements. Electric shock can cause physical injury or death.
- Use only stranded, shielded or unshielded copper communications / power wiring from the outdoor unit to the indoor units. If shielded, wiring must be grounded to the chassis at the outdoor unit only. Improper wiring may result in fire, electric shock, physical injury or death.
- Ground wiring is required to prevent accidental electrical shock during current leakage, communication problems from electrical noise, and motor current leakage. Do not connect the ground line to the pipes. Improper wiring may result in fire, electric shock, physical injury or death.
- Install a main shutoff switch or circuit breaker that interrupts all power sources simultaneously. Electric shock can cause physical injury or death.
- Wiring cable size must comply with applicable national, state, and local codes. Improper wiring may result in fire, electric shock, physical injury or death.

Note:

- For Multi F with LGRED, refer to Multi F & Multi F MAX with LGRED ODU engineering manual.
- Ground wiring is required to prevent communication problems from electrical noise, and motor current leakage. Failure to provide proper ground wiring can result in property damage and equipment malfunction.
- All field-supplied wiring, components, and materials should follow national, state, and local codes and requirements. Failure to install proper electrical components can result in property damage and equipment malfunction.
- Use only stranded, shielded or unshielded copper communications / power wiring from the outdoor unit to the indoor units. If shielded, wiring must be grounded to the chassis at the outdoor unit only. Failure to install proper wiring can result in property damage and equipment malfunction.
- Install a main shutoff switch or circuit breaker that interrupts all power sources simultaneously. Failure to install proper electric components can result in property damage and equipment malfunction.
- Wiring cable size must comply with applicable national, state, and local codes. Improper wiring can result in property damage and equipment malfunction.



ELECTRICAL CONNECTIONS

Power Wiring (208-230V) and Communications Cable Details

MULTI F
MULTI F MAX

Figure 267: Multi F MAX LMU480HV and LMU540HV System Power Wiring and Communications Cable.

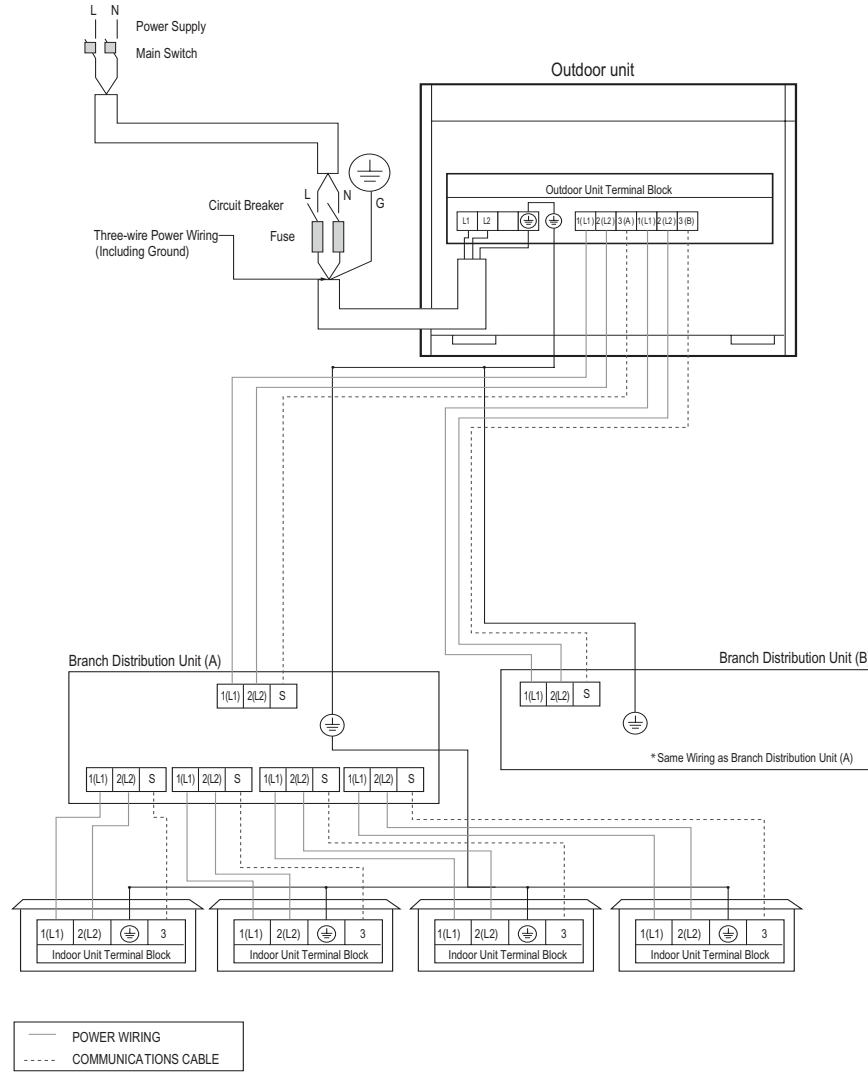

WARNING

- All field-supplied wiring, components, and materials should follow national, state, and local codes and requirements. Electric shock can cause physical injury or death.
- Use only stranded, shielded or unshielded copper communications / power wiring from the outdoor unit to the indoor units. If shielded, wiring must be grounded to the chassis at the outdoor unit only. Improper wiring may result in fire, electric shock, physical injury or death.
- Ground wiring is required to prevent accidental electrical shock during current leakage, communication problems from electrical noise, and motor current leakage. Do not connect the ground line to the pipes. Improper wiring may result in fire, electric shock, physical injury or death.
- Install a main shutoff switch or circuit breaker that interrupts all power sources simultaneously. Electric shock can cause physical injury or death.
- Wiring cable size must comply with applicable national, state, and local codes. Improper wiring may result in fire, electric shock, physical injury or death.

Note:

- For Multi F MAX with LGRED, refer to Multi F & Multi F MAX with LGRED ODU engineering manual.
- Ground wiring is required to prevent communication problems from electrical noise, and motor current leakage. Failure to provide proper ground wiring can result in property damage and equipment malfunction.
- All field-supplied wiring, components, and materials should follow national, state, and local codes and requirements. Failure to install proper electrical components can result in property damage and equipment malfunction.
- Use only stranded, shielded or unshielded copper communications / power wiring from the outdoor unit to the indoor units. If shielded, wiring must be grounded to the chassis at the outdoor unit only. Failure to install proper wiring can result in property damage and equipment malfunction.
- Install a main shutoff switch or circuit breaker that interrupts all power sources simultaneously. Failure to install proper electric components can result in property damage and equipment malfunction.
- Wiring cable size must comply with applicable national, state, and local codes. Improper wiring can result in property damage and equipment malfunction.

Figure 268: Multi F MAX LMU600HV System Power Wiring and Communications Cable.

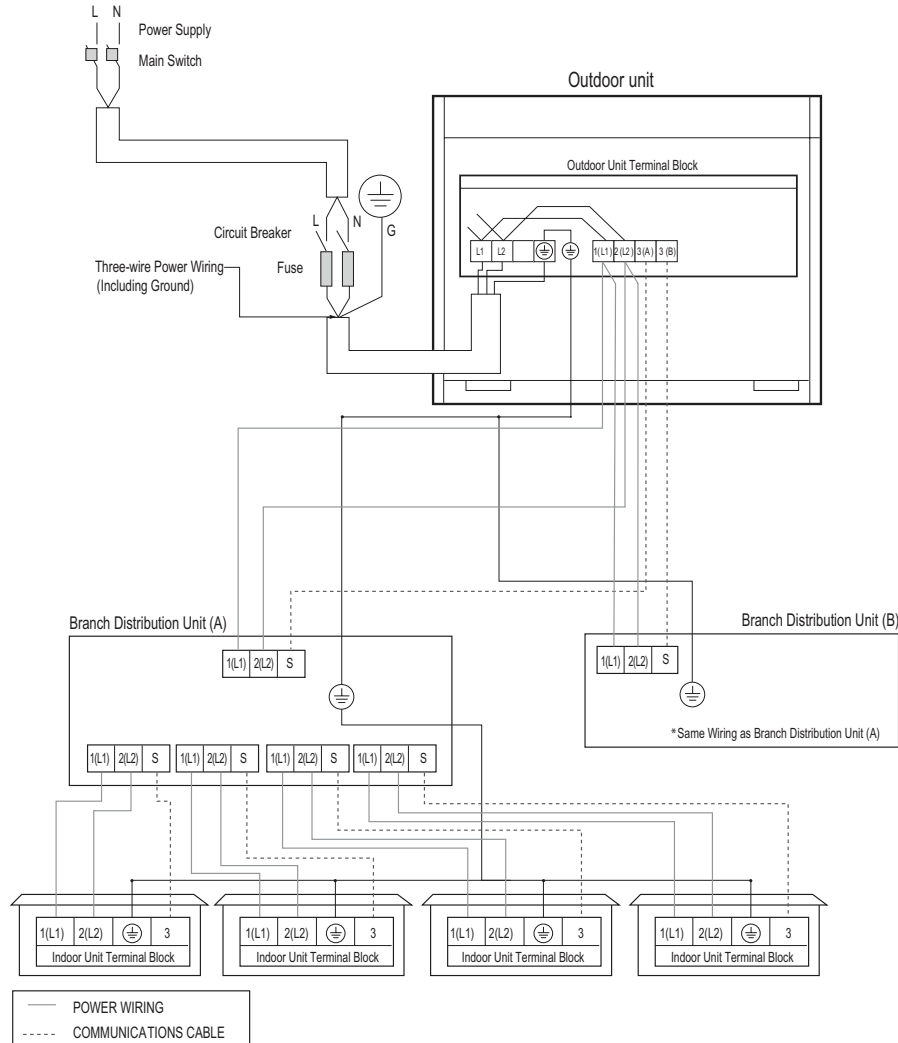

⚠ WARNING

- All field-supplied wiring, components, and materials should follow national, state, and local codes and requirements. Electric shock can cause physical injury or death.
- Use only stranded, shielded or unshielded copper communications / power wiring from the outdoor unit to the indoor units. If shielded, wiring must be grounded to the chassis at the outdoor unit only. Improper wiring may result in fire, electric shock, physical injury or death.
- Ground wiring is required to prevent accidental electrical shock during current leakage, communication problems from electrical noise, and motor current leakage. Do not connect the ground line to the pipes. Improper wiring may result in fire, electric shock, physical injury or death.
- Install a main shutoff switch or circuit breaker that interrupts all power sources simultaneously. Electric shock can cause physical injury or death.
- Wiring cable size must comply with applicable national, state, and local codes. Improper wiring may result in fire, electric shock, physical injury or death.

Note:

- For Multi F MAX with LGRED, refer to Multi F & Multi F MAX with LGRED ODU engineering manual.
- Ground wiring is required to prevent communication problems from electrical noise, and motor current leakage. Failure to provide proper ground wiring can result in property damage and equipment malfunction.
- All field-supplied wiring, components, and materials should follow national, state, and local codes and requirements. Failure to install proper electrical components can result in property damage and equipment malfunction.
- Use only stranded, shielded or unshielded copper communications / power wiring from the outdoor unit to the indoor units. If shielded, wiring must be grounded to the chassis at the outdoor unit only. Failure to install proper wiring can result in property damage and equipment malfunction.
- Install a main shutoff switch or circuit breaker that interrupts all power sources simultaneously. Failure to install proper electric components can result in property damage and equipment malfunction.
- Wiring cable size must comply with applicable national, state, and local codes. Improper wiring can result in property damage and equipment malfunction.

From Indoor Units to Remote Controllers

- Communication cable from indoor unit to remote controller(s) is to be 22 AWG, 3-conductor, twisted, stranded, unshielded. Wiring must comply with all applicable local and national codes.
- If using the LG Controller / Extension cable and the length needs to be further extended, the LG Extension Kit (sold separately) must be used. A maximum of four (4) kits (up to 165 feet) can be used.
- Remote controllers have hardwired connections: SIG - 12V - GND (Comm.) terminals.
- Indoor unit controller connections depend on type of indoor unit being installed. Some indoor units use terminal block connections; other indoor units use Molex connections. See diagrams below for the two options. Refer to the wiring diagram schematic found in the indoor unit itself, or to the indoor unit wiring diagrams in the Engineering Manuals for more information.
- ⚠ NEVER splice, cut, or extend cable length with field provided cable. Always include enough cable to cover distance between the indoor unit and the remote controller.
- Set the indoor unit operating parameters using DIP switches, or by setting up the remote controller. Refer to the indoor unit installation manuals for more details.

Figure 269: One Example of Indoor Unit to Zone Controller Connection.

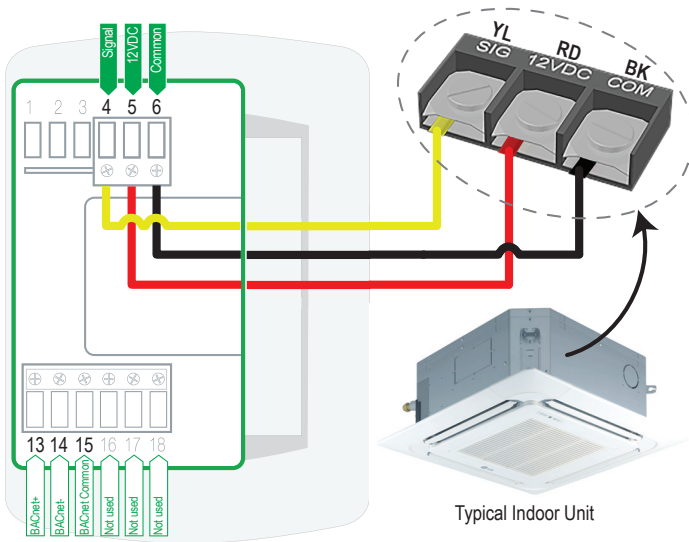

Note:

Cable connected to Zone Controller is the factory default connection.

Figure 270: Another Example of Indoor Unit to Zone Controller Connection.

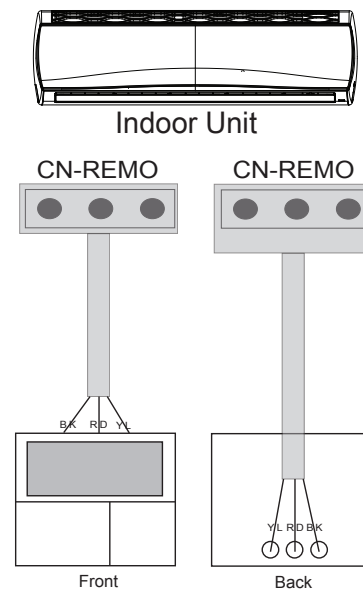

Between Multiple Indoor Units Operating as a Group (Group Control)

If any indoor units were specified to operate in unison:

- Before running cable, decide which indoor unit will be the “Master.” The other indoor units in that group will be designated as “Slave(s).” The zone controller will be connected to the “Master.”
- Set the pertinent DIP switch at each indoor unit to identify the Master and Slave(s). On wall mounted indoor unit models, set the assignment using the handheld remote controller.
- Use a daisy chain configuration and connect all of the group’s indoor units together starting at the “Master” unit.
- ⚠ NEVER splice, cut, or extend cable length with field provided cable. Always include enough cable to cover distance between all components.

For indoor units with hardwired connections SIG - 12V - GND (Comm.) terminals:

- From the controller to the master indoor unit, use 22 AWG, 3-conductor, twisted, stranded, unshielded. All wiring must comply with all applicable local / national codes.
- From the master indoor unit to the slave indoor unit(s), daisy chain using 22 AWG, 3-conductor, twisted, stranded, unshielded. All wiring must comply with all applicable local / national codes.
- (⚠ Do not attach wire to 12VDC terminal to the slave indoor units). All wiring must comply with all applicable local and national codes.
- ⚠ NEVER splice, cut, or extend cable length; always include enough cable to cover distance between all components.

For indoor units with CN-REMO connections:

Use one (or multiple) Group Control Kit(s) (sold separately) containing extension and Y-splitter cables. Use one (1) group control cable kit for each indoor unit in the group except for the last indoor unit. ⚠ NEVER splice, cut, or extend cable length with field provided cable.

Note:

- Cable connected to zone controller is the factory default connection.
- Indoor unit connections depend on indoor unit type.

General Specifications

- Wired remote controllers can be connected to all indoor unit types.
- Wireless controllers can be used in conjunction with wired remote controllers.
- A dry contact unit can be connected with a central controller simultaneously.
 - The master indoor unit is recognized by the dry contact unit and the central controller.
 - Group Control only available for indoor units manufactured after February 2009.
 - The central controller can control indoor units after setting the address of the master indoor unit only.
 - Slave indoor unit cannot be individually controlled by central controller.
 - Slave indoor unit will operate like master indoor unit.
- If an error occurs with the indoor unit, the error will be displayed on the wired remote controller.
- The following functions are available with group control:
 - Selection of operation options (operation/mode/set temperature)
 - Control of air flow rate (High/Medium/Low)

Figure 271: Example of Indoor Unit Group to Zone Controller Connections (Sig-12V-GND [Comm.] Terminal).

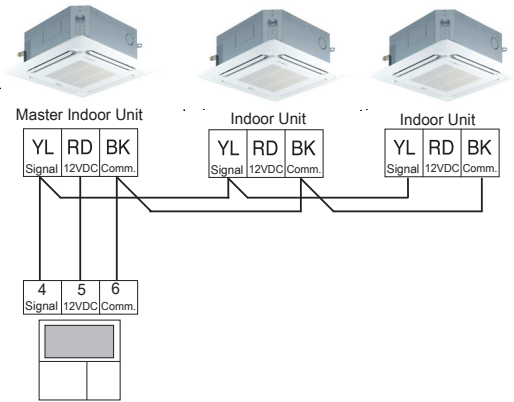

Figure 272: Example of Indoor Unit Group to Zone Controller Connections (CN-REMO).

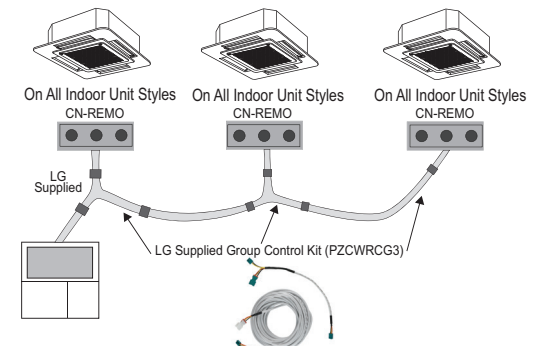

Table 126: Accessories for Some Group Control Applications.

Accessory	Model Number	Image
Wired Remote Group Control Cable Assembly - Required for connecting multiple indoor units to a control group	PZCWRG3	
Wired Remote/Wired Remote Extension Cable - Required for extending the distance between indoor units or remote controllers in a control group	PZCWRC1	

Table 127: Table of Acronyms.

ABS	Acrylonitrile Butadiene Styrene	IAQ	Indoor Air Quality
AC	Air Conditioner	IDU	Indoor Unit
ACP	Advanced Control Platform	IUCF	Indoor Unit Correction Factor
ARI	Air Conditioning and Refrigeration Institute	KTL	Korea Testing Laboratories
ASHRAE	American Society of Heating, Refrigeration, and Air Conditioning	LATS	LG Air Conditioning Technical Solution
AWG	American Wire Gauge	LGAP	LG Air Conditioner Protocol
BDU	Branch Distribution (Unit)	MAT	Mixed Air Temperature
Btu/h	British Thermal Units per hour	MBh	Thousands BTUs per hour
CCR	Corrected Capacity Ratio	MCA	Maximum Circuit Ampacity
CDOA	Coupled Dedicated Outdoor Air	MFS	Maximum Fuse Size
CFM	Cubic Feet per Minute	NEC	National Electrical Code
CR	Combination Ratio	OAT	Outdoor Air Temperature
DB	Dry Bulb	ODU	Outdoor Unit
dB(A)	Decibels with "A" frequency weighting	OUCF	Outdoor Unit Correction Factor
DDOAS	Decoupled Dedicated Outdoor Air	PDI	Power Distribution Indicator
DFS	Duct-Free Split	PI	Power Input
DI	Digital Input	PTAC	Packaged Terminal Air Conditioner
DO	Digital Output	PVE	Polyvinyl Ether
EEV	Electronic Expansion Valve	RAT	Return Air Temperature
ELF	Equivalent Length in Feet	RCL	Refrigerant Concentration Limit
EPDM	Ethylene Propylene Diene M-Class Rubber	SC	Sensible Capacity
ESP	External Static Pressure	TC	Total Capacity
ETL	Electronic Testing Laboratories	VAV	Variable Air Volume
HACR	Heating, Air Conditioning, and Refrigeration	VRF	Variable Refrigerant Flow
H/M/L	High / Medium / Low	VRP	Ventilation Rate Procedure

Inverter



LG Electronics, U.S.A., Inc.
Commercial Air Conditioning Division
4300 North Point Parkway
Alpharetta, Georgia 30022
www.lg-dfs.com

LG Electronics Products Support
1-888-865-3026 USA
Follow the prompts for HVAC products.

EM_MultiF_IDU_3_18
Supersedes EM_MultiF_IDU_10_17
EM_MultiF_IDU_11_16
EM_MultiF_IDU_7_16
EM_MultiF_IDU_7_15
EM-MultiFIDU-01-15
EM-MultiFIDU-06-14
DFS-EM-AJ-002-US 014A03