

ELECTRONIC HOMESTYLE

COMMERCIAL STACK DRYER

Built for Reliable Performance

Speed Queen® dryers do more than dry your laundry - they dry it to perfection each and every load for the life of the machine. Through special drying cycles, a flawless Axial Airflow pattern and advanced moisture sensing, you can eliminate excessive drying and save money on your utility bill. Speed Queen's dryers provide the perfect balance of heat, airflow and tumble action for optimal performance and efficiency. Speed Queen's stack dryer offers the same great features as the single load dryer. Two commercial dryers in the space of one, both operating independently, including independent controls for optimum usage. ADA Compliant (bottom dryer only).

- Industry's largest door opening 2.06 sq. ft. (1914 cm²)
- Quiet, efficient blower system
- High efficiency exhaust blower with superior airflow 220 cfm (105 liters/sec)
- 100% serviceable from the front
- Space-saving narrow cabinet 26.875" (683 mm)
- Upfront lint filter easy to clean and secured
- Durable galvanized steel cylinder

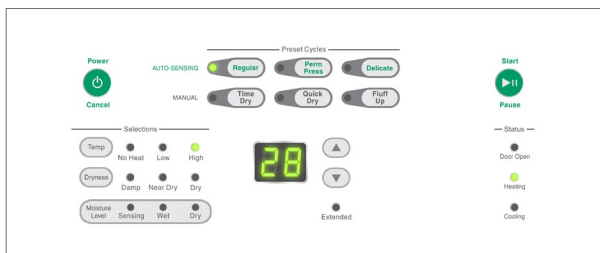

Electronic homestyle control is designed for durability and easy operation with attractive selection buttons and cycle status indicator lights.

SPECIFICATIONS

COMMERCIAL STACK DRYER

MODEL - see below for all models and activation available	
CONTROL OPTION	Electronic Homestyle
COLOR	White
CAPACITY - lb (kg)	18 (8.2) ea
CYLINDER VOLUME - cu. ft. (liters)	7.0 (198) ea
MOTOR (THERMAL PROTECTED)	0.33 HP
TYPE OF GAS (GAS MODELS ONLY)	Factory equipped natural/mixed gas
AIR OUTLET DIAMETER - in (mm)	4 (102)
EXHAUST AIRFLOW - cfm (liters/sec)	220 (105)
AVAILABLE CYCLES	Regular, Permanent Press, Delicate, Time Dry, Quick Dry, Fluff Up
ELECTRICAL REQUIREMENTS ♦	Electric 120/240/60/1-30 amp 120/208/240/60/1-30 amp
	Gas 120/60/1-15 amp
HEATING ELEMENT	Electric 5350W, 240V 4750W, 208V
	Gas 25,000 Btu
NET WEIGHT - lb (kg)	Electric 262 (119)
	Gas 262 (119)
SHIPPING WEIGHT lb (kg)	Electric 272 (123.4)
	Gas 272 (123.4)
SHIPPING DIMENSIONS APPROX. - in (mm)	Width 33 (838)
	Depth 30 (762)
	Height 80 (2032)
AGENCY APPROVALS	Electric cULus
	Gas cCSAus

MODELS	VOLTAGE/FREQ/PH	
LSEE5AGW173TW01	120/240/60/1	Electric
LSEE5AGW153TW01	120/208/240/60/1	Electric
LSGE5AGW113TW01	120/60/1	Gas

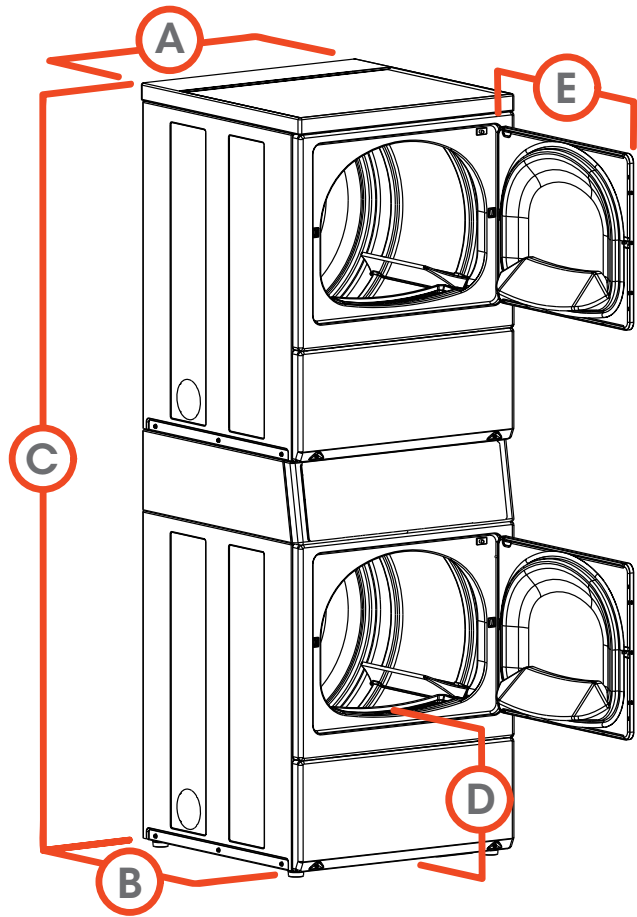

A. OVERALL WIDTH - in (mm)	26.875 (683)
B. OVERALL DEPTH - in (mm)	28 (711)
C. OVERALL HEIGHT - in (mm)	78.17 (1986)
D. FLOOR TO DOOR OPENING - in (mm)	15.44 (392)
E. DOOR SWING - in (mm)	23.5 (597)

♦ NOTE: Each stack dryer pocket requires its own separate power cord (not supplied).

■ Electric dryers come equipped for 240/60/1 operation. They can be field converted to operate on 208/60/1 with optional 61928 conversion kit. Gas dryers can be field converted for operation on LP gas with optional 458P3 conversion kit.

For the most accurate information, the installation guide should be used for all design and construction purposes. Due to continuous product improvements, design and specifications subject to change without notice. The quality management system of Alliance Laundry Systems' Ripon facility has been registered to ISO 9001:2008.



by Alliance Laundry Systems

speedqueencommercial.com/multihousing

AM18-0131 • ©2018 Alliance Laundry Systems LLC