

LSCE305ST LSCE365ST

30" & 36" Radiant Cooktops



Premium Style & Great Features

COOKING PERFORMANCE

- Electric Cooktops with 5 Elements
- Steady Heat Elements
- Double RF 9"/6", Double LR 8"/5" (LSCE305ST)
- Triple 12"/9"/6", Double 9"/6" (LSCE365ST)

STYLE AND DESIGN

- Premium Stainless Steel Trim

CONVENIENCE

- SmoothTouch™ Glass Controls
- Bridge Element – 7" (LSCE365ST)



● Stainless Steel (ST)

LSCE305ST LSCE365ST

30" & 36" Radiant Cooktops

Steady Heat Elements

Steady Heat cooking elements deliver constant heat at any temperature for more precise heat control, and respond quickly to every power setting adjustment.

Dual & Triple Elements

LG's premium cooktops offer versatile elements that fit different sized cookware for convenience and even heating.

SmoothTouch™ Glass Controls

Intuitive SmoothTouch™ Controls are extremely easy to use with just a touch. With just a quick glance of the centralized electronic controls you can see which heating elements are activated, and the smooth surface easily wipes clean.

Bridge Element (LSCE365ST)

In addition to being used separately, the left front and the left rear elements can be joined by the bridge element to evenly heat larger pans.



Installation Reference

(See chart at right for measurements)

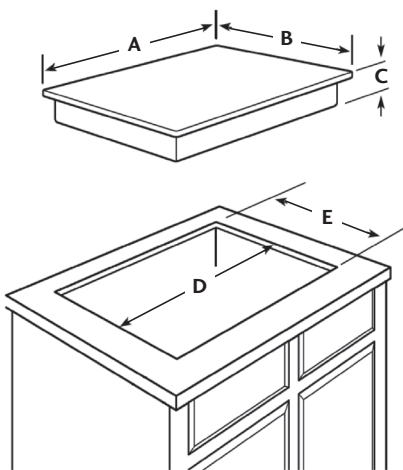

TYPE	
Type	Electric
Size (LSCE305ST)	30"
Size (LSCE365ST)	36"
Cooking Surface	Radiant Glass Surface
Number of Elements	5 (plus bridge element - LSCE365ST)
FEATURES	
Controls Type / Location	SmoothTouch™ / Front Center
Hot Surface Indicator	•
Child Lock	•
Auto Shut Off	•
Under Bench Oven Capable	•
Warm Function	•
Power Control	Steady Heat
Elements	Ceramic Glass
Surface / Frame Trim	Black / Stainless Steel
CONFIGURATION (LSCE305ST)	
Element Configuration	
Left Front	6" / 1.2kW
Left Rear	8", 5" / 1.9, 0.95kW (Dual)
Center	7" / 1.5kW
Right Front	9", 6" / 3.0, 1.4kW (Dual)
Right Rear	6" / 0.1kW (Warm)
CONFIGURATION (LSCE365ST)	
Element Configuration	
Left Front	7" / 1.8kW
Left Rear	7" / 1.8kW
Center	12", 9", 6" / 3.0, 2.2, 1.1kW (Triple)
Right Front	9", 6" / 3.0, 1.4kW (Dual)
Right Rear	6" / 0.1kW (Warm)
Bridge	7" / 0.8kW (Bridge)
DIMENSIONS (LSCE305ST)	
A: Product Width	30 27/32"
B: Product Depth	21 47/64"
C: Product Height	4"
D: Cut-Out Width	29 3/8"
E: Cut-Out Depth	20 1/4"
Net Weight	34.2 lbs.
DIMENSIONS (LSCE365ST)	
A: Product Width	36 11/16"
B: Product Depth	22 33/64"
C: Product Height	4"
D: Cut-Out Width	34 9/16"
E: Cut-Out Depth	20 3/8"
Net Weight	43 lbs.
POWER SOURCE (LSCE305ST)	
Electrical Requirements	240V/208V, 60Hz AC
Max. Amp Load	40 Amp
Power Cable Location	Right Rear
Total Connected Load	7.7kW @ 240V, 5.8kW @ 208V
POWER SOURCE (LSCE365ST)	
Electrical Requirements	240V/208V, 60Hz AC
Max. Amp Load	50 Amp
Power Cable Location	Right Rear
Total Connected Load	10.5kW @ 240V, 7.9kW @ 208V
WARRANTY	
	2 Years Parts and Labor, 5 Years Parts on Cooktop and Coils
UPC CODES	
LSCE305ST 30" Radiant Cooktop	48231316620
LSCE365ST 36" Radiant Cooktop	48231316737

www.LG.com

LG Electronics U.S.A., Inc.

1000 Sylvan Avenue Englewood Cliffs, NJ 07632
Customer Service and Technical Support: (800) 243-0000

Dimensions and weights are approximate. Design, features and specifications subject to change without notice.

© 2010 LG Electronics USA, Inc. All rights reserved. "LG Life's Good" is a registered trademark of LG Corp. All other product and brand names are trademarks or registered trademarks of their respective companies. 07/10