



SINGLE ZONE HIGH EFFICIENCY, STANDARD AND EXTENDED PIPE WALL MOUNT ENGINEERING MANUAL

AjMadison
Your Appliance Authority™

800-570-3355



Single Zone Wall Mount Systems
3/4 to 2-3/4 Tons

PROPRIETARY DATA NOTICE

This document, as well as all reports, illustrations, data, information, and other materials is the property of LG Electronics U.S.A., Inc.

AJMadison
Your Appliance Authority™

800-570-3355

DFS-EM-AH-001-US 014D10

For continual product development, LG Electronics U.S.A., Inc., reserves the right to change specifications without notice.
©LG Electronics U.S.A., Inc.

About LG Electronics, Inc.

LG Electronics, Inc. is a global leader and technology innovator in consumer electronics, mobile communications, and home appliances, employing more than 213,000 people in more than 60 countries worldwide. With \$136 billion (USD) revenue in 2011, LG Electronics, Inc. is ranked among Fortune 500's list of largest companies. LG Electronics, Inc. comprises five business units—Home Entertainment, Mobile Communications, Air Conditioning, Business Solutions, and Home Appliance. LG is one of the world's leading producers of flat panel televisions, audio and video products, mobile handsets, air conditioners, and washing machines. LG's commercial air conditioning business unit was established in 1968 and has built its lineup of residential and commercial products to include VRF, Flex-Multi, duct-free split systems, packaged terminal air conditioners (PTACs), and room air conditioners. In 2011, the air conditioning and energy solutions business unit grew to include LED lighting and solar products. For more information, visit www.lg.com.

Duct Free Split (DFS) Technology

LG HVAC systems offer a range of solutions that are cost efficient, quiet and attractive. Duct-Free Split (DFS) systems are "split" into indoor and outdoor units, and provide a smart alternative to both central HVAC and window-mounted air conditioners. These inverter

heat pump systems are available in a variety of configurations to suit different cooling and heating situations. Installation by a qualified HVAC contractor is safe and easy – little to no duct work or sheet metal is required.

Inverter Systems

LG Single Zone Inverter Wall Mount air-source systems offer the opportunity to minimize ductwork in the same configuration. The system offers zoning without the need for zone damper systems. The LG Single Zone Inverter Wall Mount system's advanced controls provide exceptional building dehumidification and temperature control, and can rapidly adapt system operating parameters to the ever changing building load. The LG Single Zone Inverter Wall Mount system is easy to design, install, and maintain. The modular design allows occupants to control their environmental condition, providing individualized control of the set-point temperature and allowing occupants to condition only the occupied zones.

Quality Commitment

LG is committed to the success of DFS projects. We provide industry leading technical support during installation and commissioning. LG offers a variety of classes designed for installers and servicers to ensure that every DFS system installation is completed successfully. Classes are conducted at LG's training centers and in field locations at various times throughout the year and upon special request.





TABLE OF CONTENTS

Architectural Appeal.....	6	Accessories	40-42
Product Features and Benefits	8	Performance Data.....	43-51
Unit Nomenclature.....	9	Equipment Selection Procedure	54-56
General Data	10-17	Building Ventilation Design Guide.....	57-58
Electrical Data.....	18	Placement Considerations	59-61
Outdoor Unit Dimensions	19-21	Refrigerant Piping Design	64-65
Indoor Unit Dimensions	22-25	Installation & Layout Best Practices	66-70
Outdoor Unit Acoustic Data.....	26	Electrical Connections.....	71-72
Indoor Unit Acoustic Data.....	27-28	Mechanical Specifications.....	74
Refrigerant Flow Diagrams.....	29-32	Acronyms	75
Wiring Diagrams	33-39		



TABLE OF SYMBOLS

 WARNING	<i>This symbol indicates a potentially hazardous situation which, if not avoided, may result in death, serious injury, property damage or equipment damage.</i>
Note	<i>This symbol indicates additional helpful information such as an explanation, a comment, or a clarification about the subject.</i>
	<i>This symbol indicates a recommendation or tip. Recommendations instruct the user to apply the suggested practice to ensure the best operating results in order to achieve the maximum benefit of the product. Tips contain practical information that may help the user solve a problem or describe actions that may save time.</i>

INTRODUCTION

“Architectural Appeal” on page 6

AjMadison
Your Appliance Authority™

800-570-3355

ARCHITECTURAL APPEAL

Convergence of Technological Innovation with Flexibility and Style

Benefits of Single Zone Wall Mount Systems

- Available from 9,000 - 33,000 Btu/h
- Inverter technology
- All season use - heat pump models for both cooling and heating capabilities
- Operating range for outdoor units of 14°F to 118°F in cooling and -4°F to 75°F in heating
- Operating range for indoor units of 64°F to 90°F in cooling and 60°F to 86°F in heating
- Quiet operation inside and outside
- Duct-free split system

Single Zone Inverter Wall Mount Systems

Single zone wall mount duct free split (DFS) systems are among the industry's best air-conditioning units. Choosing an LG single zone wall mount product provides a system designer an edge to engineer a system with individual control, and design flexibility with advanced controls.

Single zone systems are available in a nominal capacity range of 3/4 to 2-3/4 tons. These are best suited for applications with zones that require heating or cooling, such as residential, and small business office buildings. Single zone wall mount outdoor and indoor units are available in 208–230V/60Hz/1Ph.

Adaptable and Flexible

Single zone wall mount duct-free split (DFS) systems allow cooling or heating for the entire residence or just a single room without the need for evasive ductwork. There is no tearing down of walls or altering the homes appearance. Long refrigerant piping lengths allow for extra design flexibility in indoor unit installation.

These units may be used for a number of residential or commercial environments such as:

- Older homes
- New home construction
- Office buildings
- Restaurants
- Hospitals / Medical facilities
- Schools
- Nursing homes
- Retail establishments
- Place of worship

Inverter Technology

Inverter variable-speed DFS systems are measurably quieter and consume less energy than conventional air conditioners. The inverter compressor ramps up or down to match the required room capacity and maintain the comfort level. When the selected temperature is reached, the inverter compressor operates at low speed to maintain that comfort level, thereby using less energy.



PRODUCT DATA

“Product Features and Benefits” on page 8

“Unit Nomenclature” on page 9

“General Data” on page 10

“Electrical Data” on page 18

“Outdoor Unit Dimensions” on page 19

“Indoor Unit Dimensions” on page 22

“Acoustic Data” on page 26

“Refrigerant Flow Diagrams” on page 29

“Wiring Diagrams” on page 33

“Accessories” on page 40

PRODUCT FEATURES AND BENEFITS

Single Zone Systems

Single zone systems are equipped with inverter components that offer superior load matching and long piping installation. The product works for optimizing power consumption in residential and small office buildings. Utilizing multiple indoor wall mount units each with custom temperature controls allow for precise temperature settings in each zone of the building. Single zone systems allow flexibility in interior design and complement any decor.

Low Sound Levels

When outdoor units operate fully loaded, they have one of the quietest sound levels in the industry. Sound is almost undetectable during off-peak operation. To promote a quiet, comfortable environment, the single zone system indoor units operate at sound levels as low as 24 dB(A) (High Efficiency Single Zone) and outdoor units as low as 45 dB(A) at full load (High Efficiency Single Zone). LG customers often ask if the outdoor unit is running after commissioning is complete. All rotating components are soft-started by the controller using digitally controlled inverters, which reduce undesirable noise caused by fans and compressors cycling on and off.

Comfort Control at Its Best

Tight temperature control through precise load matching maximizes the time that the indoor units remove moisture. Unlike traditional air conditioning control systems, which use thermostatic controls to maintain room temperatures, LG Single Zone Inverter controls continuously adjust the indoor unit fan speed and refrigerant flow, indirectly providing lower and more consistent humidity levels in the conditioned space. The longer the indoor coil temperature is below the dew-point of the room in conjunction with air movement across the coil, the space humidity level will vary little, compared to technologies that cycle fans and compressors on and off multiple times per hour. The outdoor unit responds by varying the compressor speed and outdoor fan motors as needed to maintain system operating pressure. As a result, the single zone systems deliver precise space temperature control.

Inverter Driven

The rotary (9k-12k Btu/h systems) and twin rotary (18k-36k Btu/h systems) compressors are optimized to maximize compressor efficiency, which reduces power consumption and monthly utility bills. This latest inverter technology allows single zone system outdoor units to vary the compressor motor shaft speed to deliver an appropriate amount of cooling to the indoor unit. Precise refrigerant volume delivery translates into long periods with coil surface temperatures below dew point and minimizes compressor and fan component run time. Occupants remain comfortable while utility costs are reduced.

Simplified Installation

Cooling and heating applications that use single zone systems simplify and reduce the mechanical and control system design time. The designer no longer has to be concerned with interconnecting chilled and condenser water piping, air-distribution duct systems, matching and selecting chillers, towers, pumps, coils, fans, air handlers, or Variable Air Volume (VAV) boxes.

Operating Range

Single zone systems have a nominal capacity range of 3/4 to 2-3/4 tons (depending on outdoor/indoor units).

Operating ranges for single zone systems:

Cooling: 14°F DB to 118°F DB

Heating: -4°F WB to 75°F WB

Installing an optional Low Ambient Wind Baffle Kit will allow operation down to 0°F in cooling mode for all single zone systems.

Compact Size

Single zone outdoor units have the following footprints:

Single Zone High Efficiency

LSU091HSV3, LSU121HSV3

(WxHxD (in)) 30 5/16 x 21 1/2 x 11 5/16.

LSU181HSV3, LSU240HSV3

(WxHxD (in)) 34-1/4 x 31-1/2 x 12-5/8.

Single Zone Standard

LSU307HV3, LSU360HV3

(WxHxD (in)) 34-1/4 x 31-1/2 x 12-5/8.

Single Zone Extended Pipe

LSU240HLV, LSU300HLV, LSU360HLV

(WxHxD (in)) 34-1/4 x 31-1/2 x 12-5/8.

Fin Design with Gold-Fin™ Coating

All single zone outdoor units are provided with large surface coils made of copper tubes with louvered aluminum fins designed to maximize unit operating efficiency over a wide range of ambient conditions.

Standard from the factory, every single zone outdoor unit coil fin surface is coated with LG's exclusive GoldFin™ anti-corrosive coating designed to prevent natural surface corrosion of the aluminum fins. This maintains heat transfer properties of the coil for an extended time.

A hydrophilic coating is applied to the outdoor unit coil fin surface over the GoldFin coating. This coating enhances the development of heavier water droplets gathering on the fin surface. As a result, the droplets roll off the fin surfaces, delaying the point when frost forms on the coil surface during heating operation. This coating also makes it possible to easily clean the outdoor unit coil using a mild soap.

Other Features

- Inverter variable speed compressor
- Jet Cool / Jet Heat
- Dehumidifying mode
- Chaos Wind
- Auto restart
- Auto operation
- Self-cleaning indoor coil
- Condensate sensor connection
- Cooling only function
- Precision load matching
- Meets AHRI 210/240



UNIT NOMENCLATURE

Single Zone Indoor and Outdoor Units

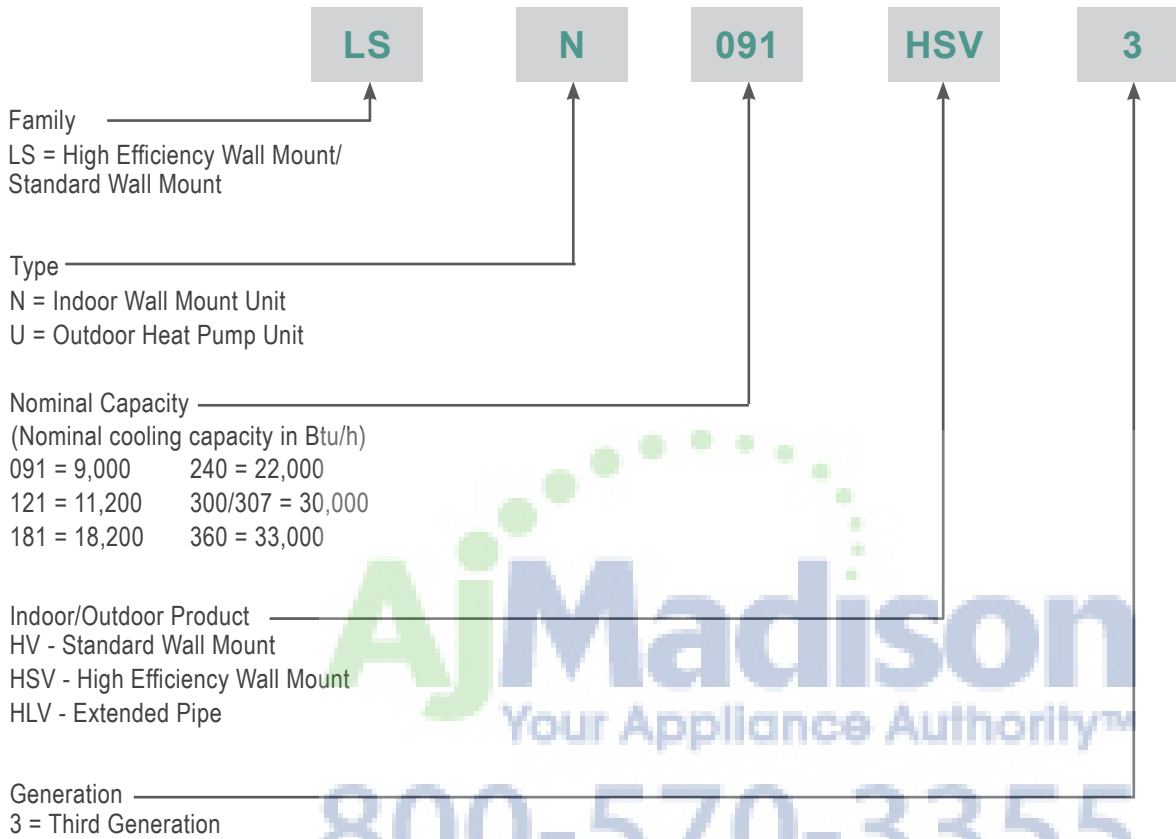

Product Data



GENERAL DATA

Single Zone High Efficiency & Single Zone Standard System Pairing Table

The following tables show the available outdoor and indoor units, along with the factory provided controllers.

Table 1: Single Zone High Efficiency & Single Zone Standard System Pairing Table



Outdoor Unit Model	Indoor Unit Model	Controller
LSU091HSV3 LSU121HSV3 	LSN091HSV3 LSN121HSV3 	AKB73855712 
LSU181HSV3 	LSN181HSV3 	AKB73855712 
LSU240HSV3 	LSN240HSV3 	AKB73855713 
LSU307HV3 LSU360HV3 	LSN307HV3 LSN360HV3 	AKB73855713 



GENERAL DATA

Single Zone Extended Pipe System Pairing Table

Table 2: Single Zone Extended Pipe System Pairing Table

Outdoor Unit Model	Indoor Unit Model	Controller
<p>LSU240HLV LSU300HLV LSU360HLV</p> 	<p>LSN240HLV LSN300HLV LSN360HLV</p> 	<p>AKB74055401</p> 



GENERAL DATA

Single Zone High Efficiency Unit Specifications

Table 3: Single Zone High Efficiency Unit Specifications

Type	Single Zone High Efficiency Units			
System Model Number (IDU/ODU)	LS091HSV3 (LSN091HSV3/ LSU091HSV3)	LS121HSV3 (LSN121HSV3/ LSU121HSV3)	LS181HSV3 (LSN181HSV3/ LSU181HSV3)	LS240HSV3 (LSN240HSV3/ LSU240HSV3)
Nominal Cooling Capacity (Btu/h)	9,000	11,200	18,200	22,000
Cooling Power Input ¹ (kW)	0.67	0.89	1.4	1.7
Nominal Heating Capacity (Btu/h) ¹	10,800	13,300	22,000	27,600
Heating Power Input ¹ (kW)	0.70	1.0	1.7	2.3
Cooling COP	3.90	3.66	3.69	3.66
EER	13.3	12.5	12.6	12.5
SEER	21.5	21.5	20.5	20.0
HSPF	11.0	11.0	9.7	10.2
Power Supply (V/Hz/Ø)	208-230/60/1			
Outdoor Unit Operating Range²				
Cooling (°F DB)	14-118			
Heating (°F WB)	-4-75			
Indoor Unit Operating Range²				
Cooling (°F)	64-90			
Heating (°F)	60-86			
Unit Data				
Refrigerant Type ³	R410A			
Refrigerant Control	EEV			
IDU Sound Pressure ⁴ dB(A) (H/M/L)	38/33/24	39/33/24	45/40/35	46/43/39
ODU Sound Pressure ⁴ dB(A)	45	45	53	54
Power/Communication Cable ⁵ (No. x AWG)	4 x 18			
IDU Net/Shipping Weight (lbs)	23/28	23/28	32/41	36/42
ODU Net/Shipping Weight (lbs)	75/79	75/79	123/131	128/137
Compressor				
Compressor Type (Qty)	Rotary (1)	Rotary (1)	Twin Rotary (1)	Twin Rotary (1)
Fan				
IDU Type (Qty)	Cross Flow (1)			
ODU Type (Qty)	Propeller (1)			
Motor/Drive	Brushless Digitally Controlled/Direct			
Airflow Rate				
IDU Max/H/M/L (CFM)	388/335/272/212	423/353/272/212	735/622/509/399	883/742/629/424
ODU Max (CFM)	1,165	1,165	2,119	2,119

EEV: Electronic Expansion Valve IDU: Indoor Unit ODU: Outdoor Unit

¹Power Input is rated at high speed.

²Low Ambient Wind Baffle Kit allows operation down to 0°F in cooling mode.

³Take appropriate actions at the end of HVAC equipment life to recover, recycle, reclaim or destroy R410A refrigerant according to applicable regulations (40 CFR Part 82, Subpart F) under section 608 of CAA.

⁴Sound Pressure levels are tested in an anechoic chamber under ISO Standard 1996.

⁵All power/communication cables to be minimum 18 AWG, 4-conductor, stranded, shielded and must comply with applicable and national code.

Power wiring is field supplied and must comply with the applicable local and national codes

This unit comes with a dry helium charge.

This data is rated 0 ft above sea level with 24.6 of refrigerant line per indoor unit and a 0 ft level difference outdoor and indoor units.

Cooling capacity rating obtained with air entering the indoor unit at 80°F dry bulb (DB) and 67°F wet bulb (WB) and outdoor ambient conditions of 95°F dry bulb (DB) and 75°F wet bulb (WB). Heating capacity rating obtained with air entering the indoor unit at 70°F dry bulb (DB) and 59°F wet bulb (WB) and outdoor ambient conditions of 47°F dry bulb (DB) and 43°F wet bulb (WB).

GENERAL DATA

Single Zone High Efficiency Unit Specifications

Table 4: Single Zone High Efficiency Unit Specifications Continued

Type	Single Zone High Efficiency Units			
System Model Number (IDU/ODU)	LS091HSV3 (LSN091HSV3/ LSU091HSV3)	LS121HSV3 (LSN121HSV3/ LSU121HSV3)	LS181HSV3 (LSN181HSV3/ LSU181HSV3)	LS240HSV3 (LSN240HSV3/ LSU240HSV3)
<i>Piping</i>				
Liquid Line (in, OD)	1/4	1/4	3/8	3/8
Vapor Line (in, OD)	3/8	3/8	5/8	5/8
Condensation Line (OD, ID)	27/32, 5/8	27/32, 5/8	27/32, 5/8	27/32, 5/8
Additional Refrigerant Charge (oz/ft)	0.22	0.22	0.38	0.38
Max Pipe Length ⁶ (ft)	65.6	65.6	98.4	98.4
Piping Length ⁶ (no add'l refrigerant, ft)	41.0	41.0	24.6	24.6
Max Elevation Difference (ft)	32.8	32.8	49.2	49.2

EEV: Electronic Expansion Valve IDU: Indoor Unit ODU: Outdoor Unit

⁶Piping lengths are equivalent.

Power wiring is field supplied and must comply with the applicable local and national codes

This unit comes with a dry helium charge.

This data is rated 0 ft above sea level with 24.6 of refrigerant line per indoor unit and a 0 ft level difference outdoor and indoor units.

Cooling capacity rating obtained with air entering the indoor unit at 80°F dry bulb (DB) and 67°F wet bulb (WB) and outdoor ambient conditions of 95°F dry bulb (DB) and 75°F wet bulb (WB). Heating capacity rating obtained with air entering the indoor unit at 70°F dry bulb (DB) and 59°F wet bulb (WB) and outdoor ambient conditions of 47°F dry bulb (DB) and 43°F wet bulb (WB).



GENERAL DATA

Single Zone Standard Specifications

Table 5: Single Zone Standard Unit Specifications

Type	Single Zone Standard Units	
System Model Number (IDU/ODU)	LS307HV3 (LSN307HV3/LSU307HV3)	LS360HV3 (LSN360HV3/LSU360HV3)
Nominal Cooling Capacity (Btu/h)	30,000	33,000
Cooling Power Input ¹ (kW)	3.0	4.0
Nominal Heating Capacity (Btu/h) ¹	32,000	35,200
Heating Power Input ¹ (kW)	3.1	3.8
Cooling COP	2.93	2.40
EER	10.0	8.2
SEER	18.0	16.1
HSPF	9.5	9.9
Power Supply (V/Hz/Ø)	208-230/60/1	208-230/60/1
Outdoor Unit Operating Range		
Cooling (°F DB)	14-118	14-118
Heating (°F WB)	-4-75	-4-75
Indoor Unit Operating Range		
Cooling (°F)	64-90	64-90
Heating (°F)	60-86	60-86
Unit Data		
Refrigerant Type ²	R410A	R410A
Refrigerant Control	EEV	EEV
IDU Sound Pressure ³ dB(A) (H/M/L)	49/44/39	49/44/39
ODU Sound Pressure ³ dB(A)	55	55
Power/Communication Cable ⁴ (No. x AWG)	4 x 18	4 x 18
IDU Net/Shipping Weight (lbs)	36/42	36/42
ODU Net/Shipping Weight (lbs)	128/137	128/137
Compressor		
Compressor Type (Qty)	Twin Rotary (1)	Twin Rotary (1)
Fan		
IDU Type (Qty)	Cross Flow	Cross Flow
ODU Type (Qty)	Propeller	Propeller
Motor/Drive	Brushless Digitally Controlled/Direct	
Airflow Rate		
IDU Max/H/M/L (CFM)	883/770/629/424	883/795/629/424
ODU Max (CFM)	2,119	2,119

EEV: Electronic Expansion Valve IDU: Indoor Unit ODU: Outdoor Unit

¹Power Input is rated at high speed.

²Take appropriate actions at the end of HVAC equipment life to recover, recycle, reclaim or destroy R410A refrigerant according to applicable regulations (40 CFR Part 82, Subpart F) under section 608 of CAA.

³Sound Pressure levels are tested in an anechoic chamber under ISO Standard 1996.

⁴All power/communication cables to be minimum 18 AWG, 4-conductor, stranded, shielded and must comply with applicable and national code.

Power wiring is field supplied and must comply with the applicable local and national codes

This unit comes with a dry helium charge.

This data is rated 0 ft above sea level with 24.6 of refrigerant line per indoor unit and a 0 ft level difference outdoor and indoor units.

Cooling capacity rating obtained with air entering the indoor unit at 80°F dry bulb (DB) and 67°F wet bulb (WB) and outdoor ambient conditions of 95°F dry bulb (DB) and 75°F wet bulb (WB).

Heating capacity rating obtained with air entering the indoor unit at 70°F dry bulb (DB) and 59°F wet bulb (WB) and outdoor ambient conditions of 47°F dry bulb (DB) and 43°F wet bulb (WB).

GENERAL DATA

Single Zone Standard Specifications

Table 6: Single Zone Standard Unit Specifications Continued

Type	Single Zone Standard Units	
System Model Number (IDU/ODU)	LS307HV3 (LSN307HV3/LSU307HV3)	LS360HV3 (LSN360HV3/LSU360HV3)
<i>Piping</i>		
Liquid Line (in, OD)	3/8	3/8
Vapor Line (in, OD)	5/8	5/8
Condensation Line (OD/ID)	27/32, 5/8	27/32, 5/8
Additional Refrigerant Charge (oz/ft)	0.38	0.38
Max Pipe Length ⁵ (ft)	98.4	98.4
Piping Length ⁵ (no add'l refrigerant, ft)	24.6	24.6
Max Elevation Difference (ft)	49.2	49.2

EEV: Electronic Expansion Valve IDU: Indoor Unit ODU: Outdoor Unit

⁵Piping lengths are equivalent.

Power wiring is field supplied and must comply with the applicable local and national codes

This unit comes with a dry helium charge.

This data is rated 0 ft above sea level with 24.6 of refrigerant line per indoor unit and a 0 ft level difference outdoor and indoor units.

Cooling capacity rating obtained with air entering the indoor unit at 80°F dry bulb (DB) and 67°F wet bulb (WB) and outdoor ambient conditions of 95°F dry bulb (DB) and 75°F wet bulb (WB). Heating capacity rating obtained with air entering the indoor unit at 70°F dry bulb (DB) and 59°F wet bulb (WB) and outdoor ambient conditions of 47°F dry bulb (DB) and 43°F wet bulb (WB).



GENERAL DATA

Single Zone Extended Pipe Unit Specifications

Table 7: Single Zone Extended Pipe Unit Specifications

Type	Single Zone Extended Pipe Units		
System Model Number (IDU/ODU)	LS240HLV (LSN240HLV/ LSU240HLV)	LS300HLV (LSN300HLV/ LSU300HLV)	LS360HLV (LSN360HLV/ LSU360HLV)
Nominal Cooling Capacity (Btu/h)	22,000	30,000	33,000
Cooling Power Input ¹ (kW)	1.7	3.0	4.0
Nominal Heating Capacity (Btu/h) ¹	27,000	32,000	35,200
Heating Power Input ¹ (kW)	2.3	3.1	3.8
Cooling COP	3.66	2.93	2.40
EER	12.5	10.0	8.2
SEER	21.0	18.5	16.5
HSPF	11	10	10
Power Supply (V/Hz/Ø)	208-230/60/1		
Outdoor Unit Operating Range			
Cooling (°F DB)	14-118		
Heating (°F WB)	-4-75		
Indoor Unit Operating Range			
Cooling (°F)	64-90		
Heating (°F)	60-86		
Unit Data			
Refrigerant Type ²	R410A		
Refrigerant Control	EEV		
IDU Sound Pressure ³ dB(A) (H/M/L)	49/44/40	49/44/40	49/44/40
ODU Sound Pressure ³ dB(A)	55	55	55
Power/Communication Cable ⁴ (No. x AWG)	4 x 18		
IDU Net/Shipping Weight (lbs)	40/46	40/46	40/46
ODU Net/Shipping Weight (lbs)	125/133	125/133	125/133
Compressor			
Compressor Type (Qty)	Twin Rotary (1)	Twin Rotary (1)	Twin Rotary (1)
Fan			
IDU Type (Qty)	Cross Flow		
ODU Type (Qty)	Propeller		
Motor/Drive	Brushless Digitally Controlled/Direct		
Airflow Rate			
IDU Max/H/M/L (CFM)	848/706/530/459	848/706/530/459	848/706/530/459
ODU Max (CFM)	2,119	2,119	2,119

EEV: Electronic Expansion Valve IDU: Indoor Unit ODU: Outdoor Unit

¹Power Input is rated at high speed.

²Take appropriate actions at the end of HVAC equipment life to recover, recycle, reclaim or destroy R410A refrigerant according to applicable regulations (40 CFR Part 82, Subpart F) under section 608 of CAA.

³Sound Pressure levels are tested in an anechoic chamber under ISO Standard 1996.

⁴All power/communication cables to be minimum 18 AWG, 4-conductor, stranded, shielded and must comply with applicable and national code.

Power wiring is field supplied and must comply with the applicable local and national codes

This unit comes with a dry helium charge.

This data is rated 0 ft above sea level with 24.6 of refrigerant line per indoor unit and a 0 ft level difference outdoor and indoor units.

Cooling capacity rating obtained with air entering the indoor unit at 80°F dry bulb (DB) and 67°F wet bulb (WB) and outdoor ambient conditions of 95°F dry bulb (DB) and 75°F wet bulb (WB).

Heating capacity rating obtained with air entering the indoor unit at 70°F dry bulb (DB) and 59°F wet bulb (WB) and outdoor ambient conditions of 47°F dry bulb (DB) and 43°F wet bulb (WB).

GENERAL DATA

Single Zone Extended Pipe Unit Specifications

Table 8: Single Zone Extended Pipe Unit Specifications Continued

Type	Single Zone Extended Pipe Units		
System Model Number (IDU/ODU)	LS240HLV (LSN240HLV/ LSU240HLV)	LS300HLV (LSN300HLV/ LSU300HLV)	LS360HLV (LSN360HLV/ LSU360HLV)
<i>Piping</i>			
Liquid Line (in, OD)	3/8	3/8	3/8
Vapor Line (in, OD)	5/8	5/8	5/8
Condensation Line (OD, ID)	27/32, 5/8	27/32, 5/8	27/32, 5/8
Additional Refrigerant Charge (oz/ft)	0.38	0.38	0.38
Max Pipe Length ⁵ (ft)	164	164	164
Piping Length ⁵ (no add'l refrigerant, ft)	24.6	24.6	24.6
Max Elevation Difference (ft)	98.4	98.4	98.4

EEV: Electronic Expansion Valve IDU: Indoor Unit ODU: Outdoor Unit

⁵Piping lengths are equivalent.

Power wiring is field supplied and must comply with the applicable local and national codes

This unit comes with a dry helium charge.

This data is rated 0 ft above sea level with 24.6 of refrigerant line per indoor unit and a 0 ft level difference outdoor and indoor units.

Cooling capacity rating obtained with air entering the indoor unit at 80°F dry bulb (DB) and 67°F wet bulb (WB) and outdoor ambient conditions of 95°F dry bulb (DB) and 75°F wet bulb (WB).
Heating capacity rating obtained with air entering the indoor unit at 70°F dry bulb (DB) and 59°F wet bulb (WB) and outdoor ambient conditions of 47°F dry bulb (DB) and 43°F wet bulb (WB).



ELECTRICAL DATA

Table 9: Single Zone High Efficiency Unit Electrical Data

Model Number	Nom. Tons	Compressor Qty	Compressor (A) Cool/Heat	Fan Qty	ODU Fan (A)	MCA (A)	MOP (A)
LSU091HSV3	3/4	1	8.7/8.7	1	0.40	10	15
LSU121HSV3	1	1	8.7/8.7	1	0.40	10	15
LSU181HSV3	1-1/2	1	15.4/15.4	1	0.25	19	25
LSU240HSV3	1-3/4	1	15.4/15.4	1	0.25	19	25

Table 10: Single Zone Standard Unit Electrical Data

Model Number	Nom. Tons	Compressor Qty	Compressor (A) Cool/Heat	Fan Qty	ODU Fan (A)	MCA (A)	MOP (A)
LSU307HV3	2-1/2	1	15.4/15.4	1	0.25	19	25
LSU360HV3	2-3/4	1	15.4/15.4	1	0.25	19	25

Table 11: Single Zone Extended Pipe Unit Electrical Data

Model Number	Nom. Tons	Compressor Qty	Compressor (A) Cool/Heat	Fan Qty	ODU Fan (A)	MCA (A)	MOP (A)
LSU240HLV	1-3/4	1	17.3/17.3	1	0.25	23	35
LSU300HLV	2-1/2	1	17.3/17.3	1	0.25	23	35
LSU360HLV	2-3/4	1	17.3/17.3	1	0.25	23	35



OUTDOOR UNIT DIMENSIONS

LSU091HSV3, LSU121HSV3

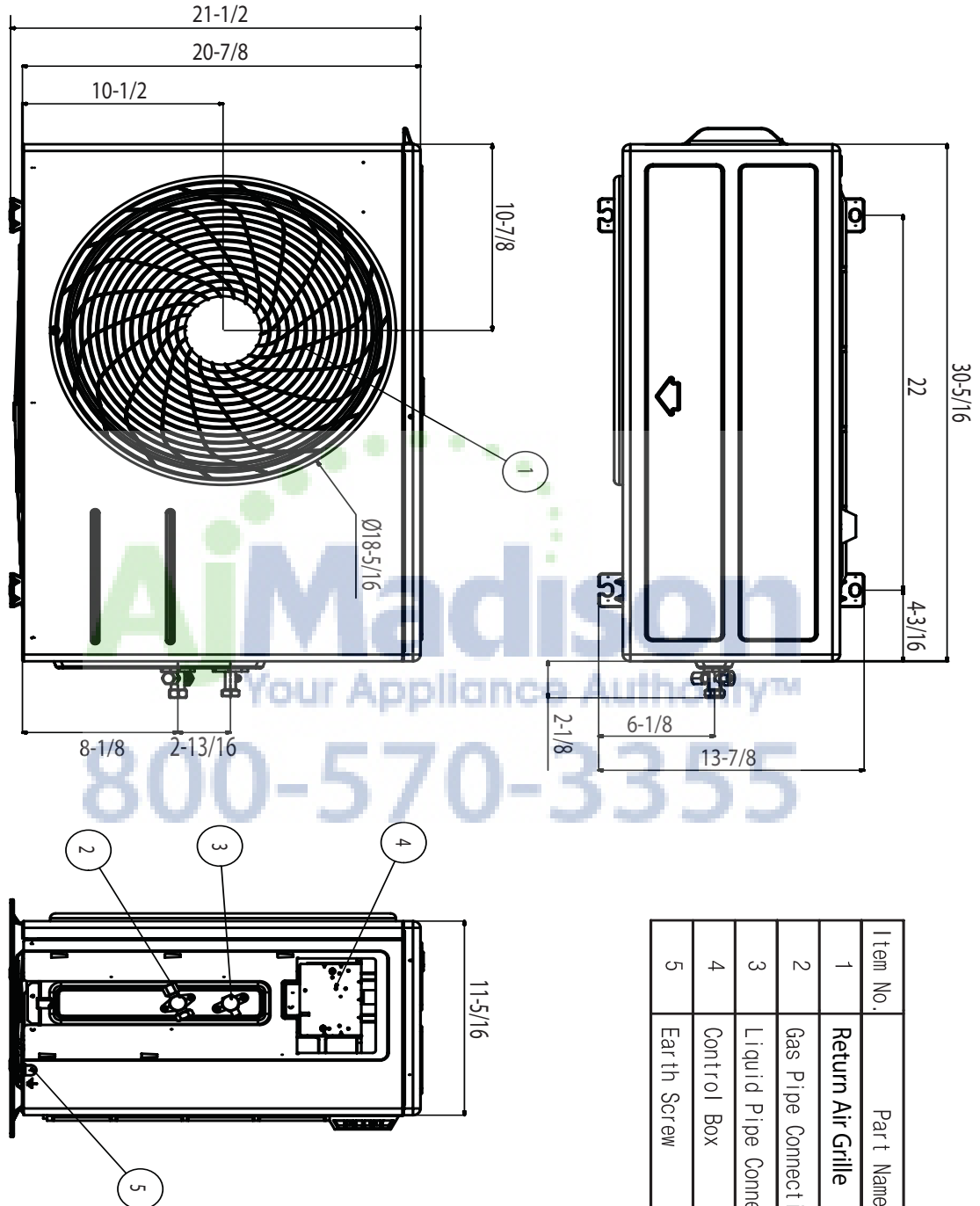

Unit: inch

Item No.	Part Name	Remarks
1	Return Air Grille	
2	Gas Pipe Connection Port	
3	Liquid Pipe Connection Port	
4	Control Box	
5	Earth Screw	

Product Data

OUTDOOR UNIT DIMENSIONS

LSU181HSV3, LSU240HSV3, LSU307HV3, LSU360HV3

Item No.	Part Name	Remarks
1	Return Air Grille	
2	Gas pipe connection	
3	Liquid pipe connection	
4	Power & Transmission connection	
5	Earth screw	
6	SVC valve cover	

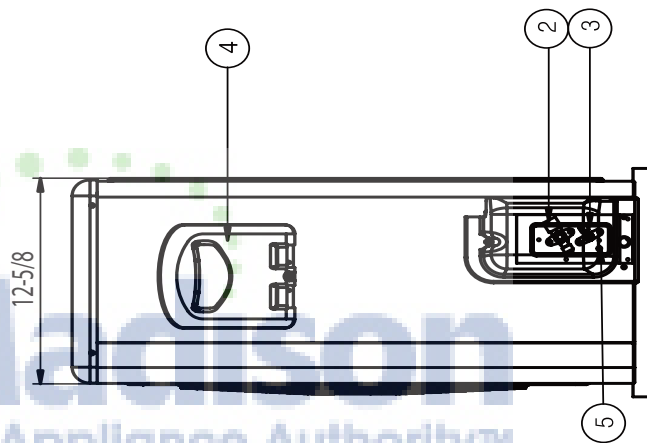
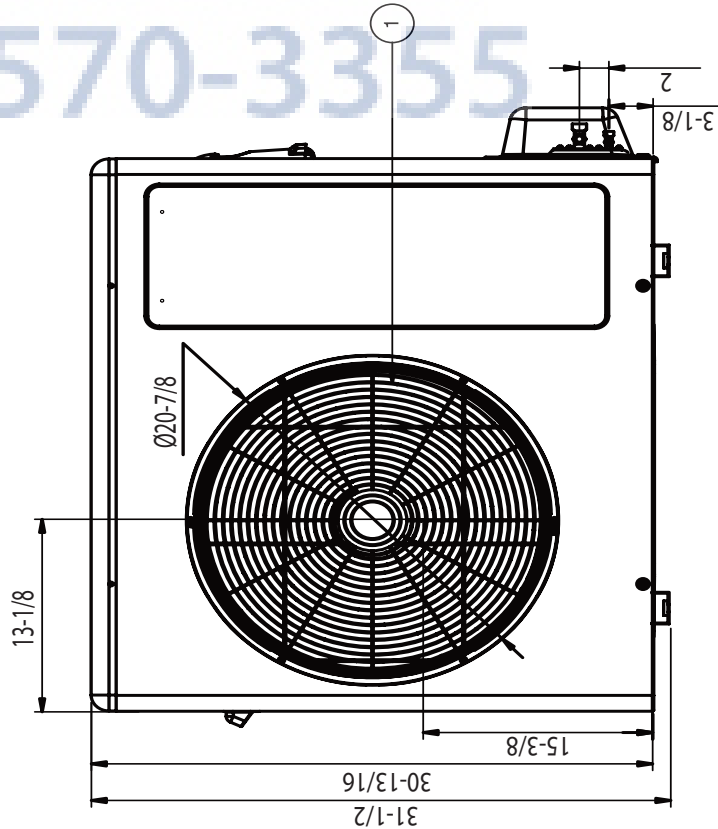
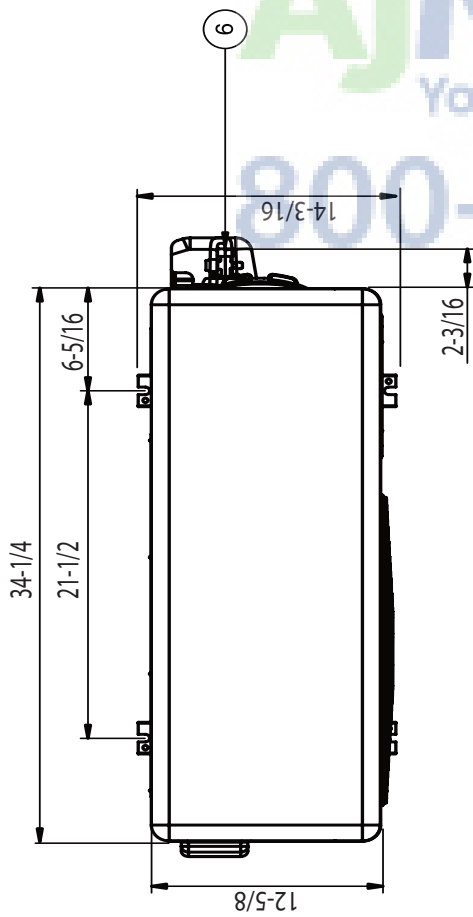

Unit: inch

AjMacalson
Your Appliance Authority™
800-570-3355

OUTDOOR UNIT DIMENSIONS

LSU240HLV, LSU300HLV, LSU360HLV

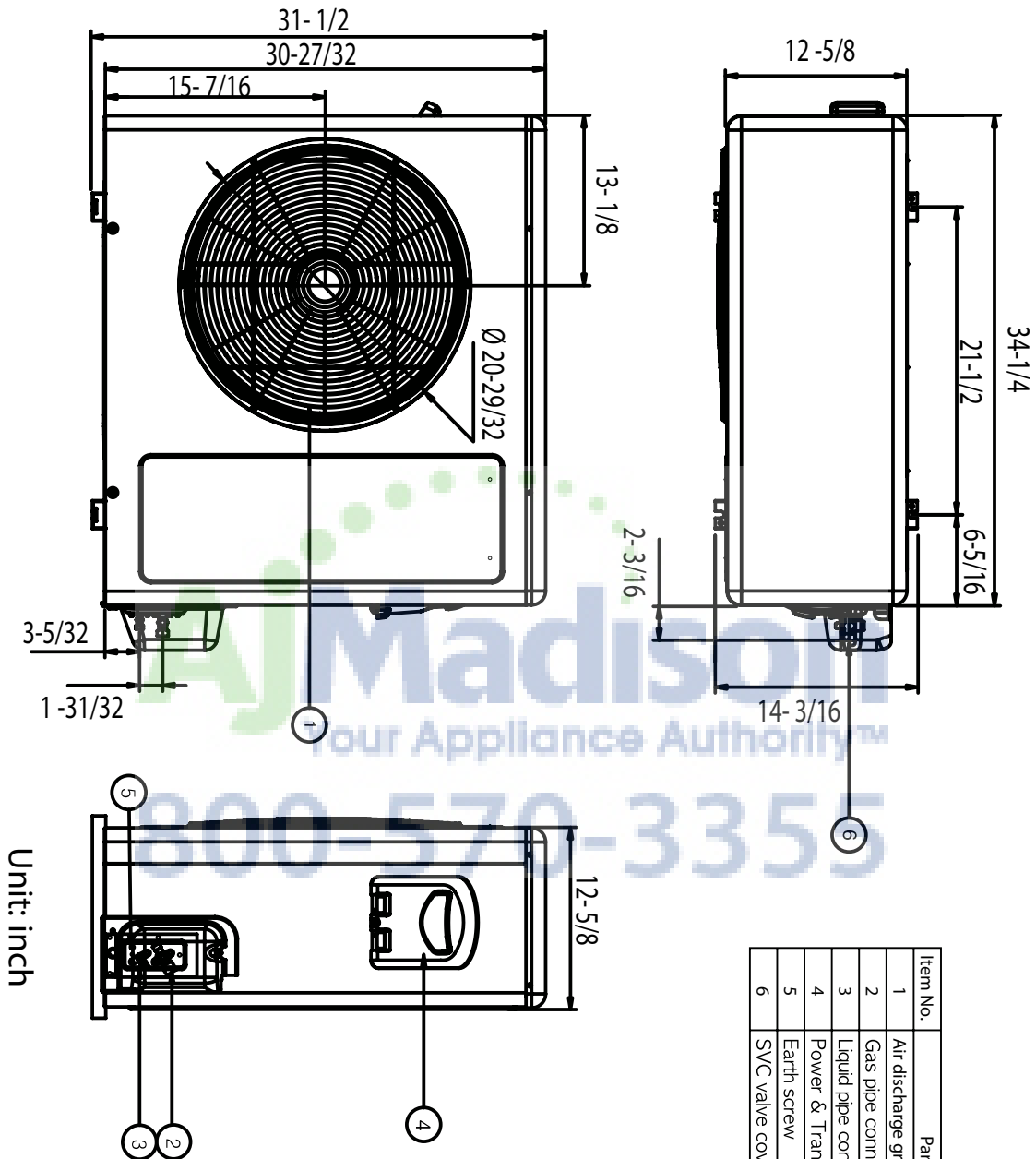

Item No.	Part Name	Remarks
1	Air discharge grille	
2	Gas pipe connection	
3	Liquid pipe connection	
4	Power & Transmission connection	
5	Earth screw	
6	SVC valve cover	

Product Data

INDOOR UNIT DIMENSIONS

LSN091HSV3, LSN121HSV3

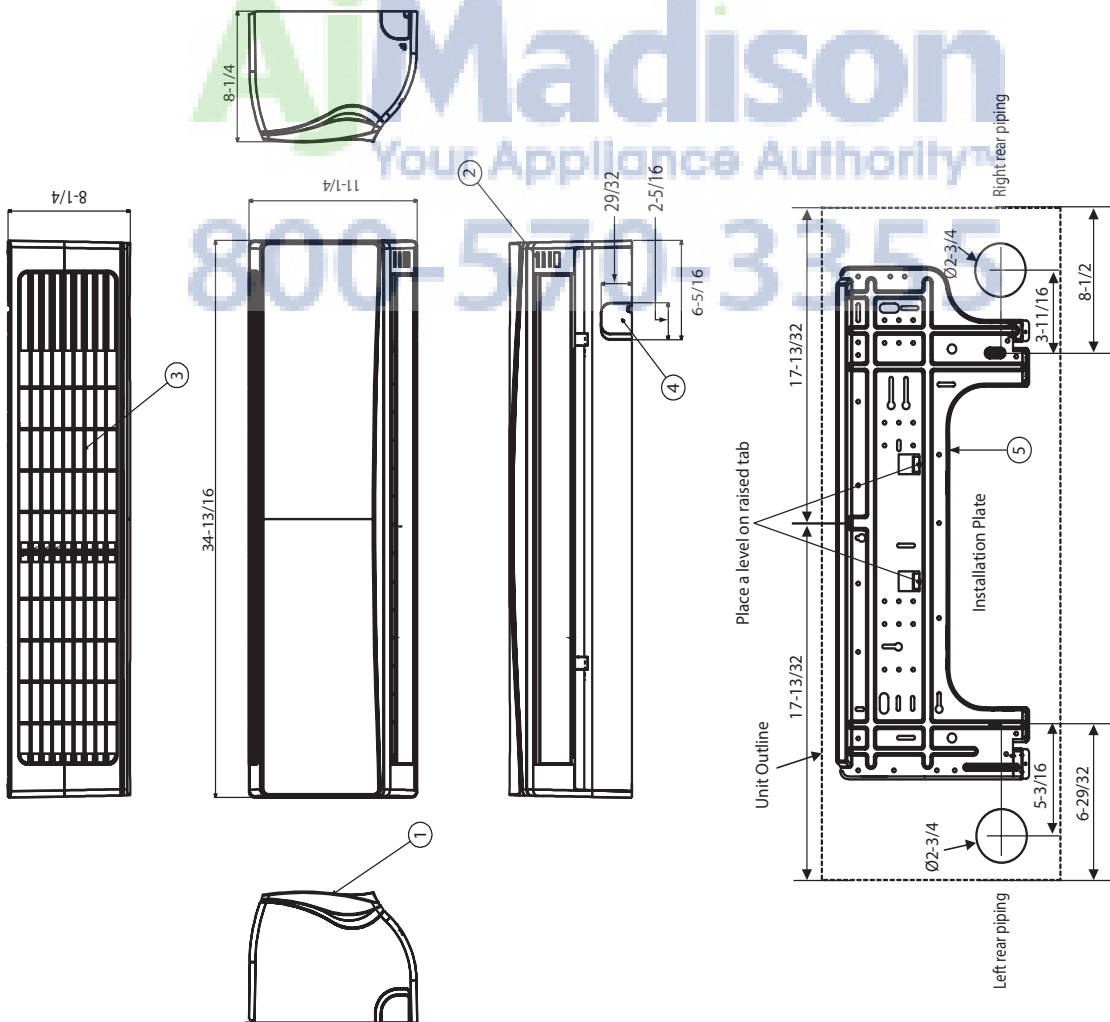

Item No.	Part Name	Remarks
1	Front Panel	
2	Display & Signal Receiver	
3	Return Air Grille	
4	Knockout hole	For pipe and cable
5	Installation Plate	

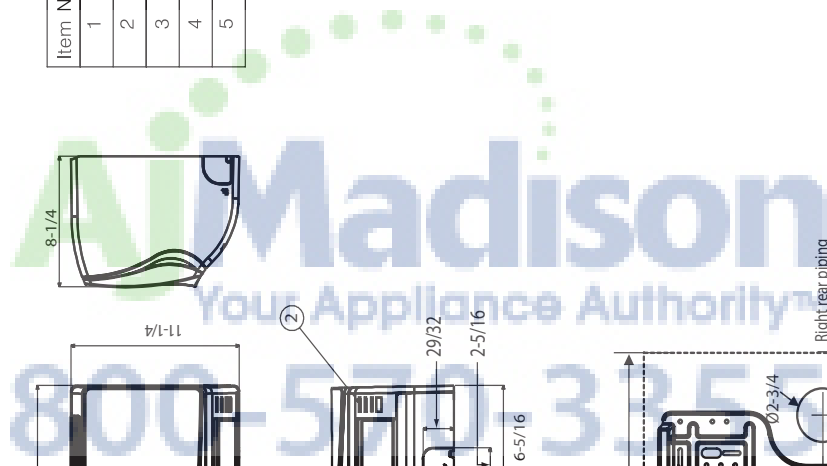

Unit: inch

INDOOR UNIT DIMENSIONS

LSN181HSV3

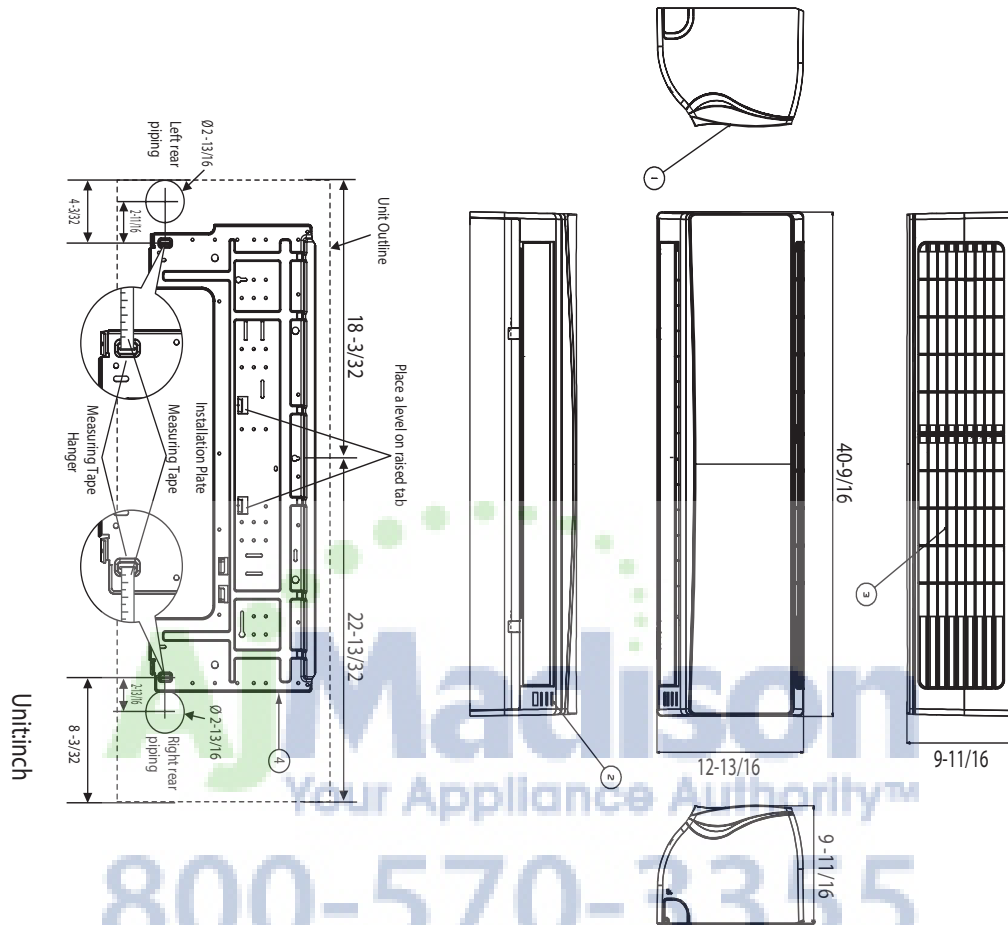

Unitinch

Product Data

Item No.	Part Name	Remark
1	Front Panel	
2	Display & Signal Receiver	
3	Air Suction Grille	
4	Installation Plate	

INDOOR UNIT DIMENSIONS

LSN240HSV3, LSN307HV3, LSN360HV3

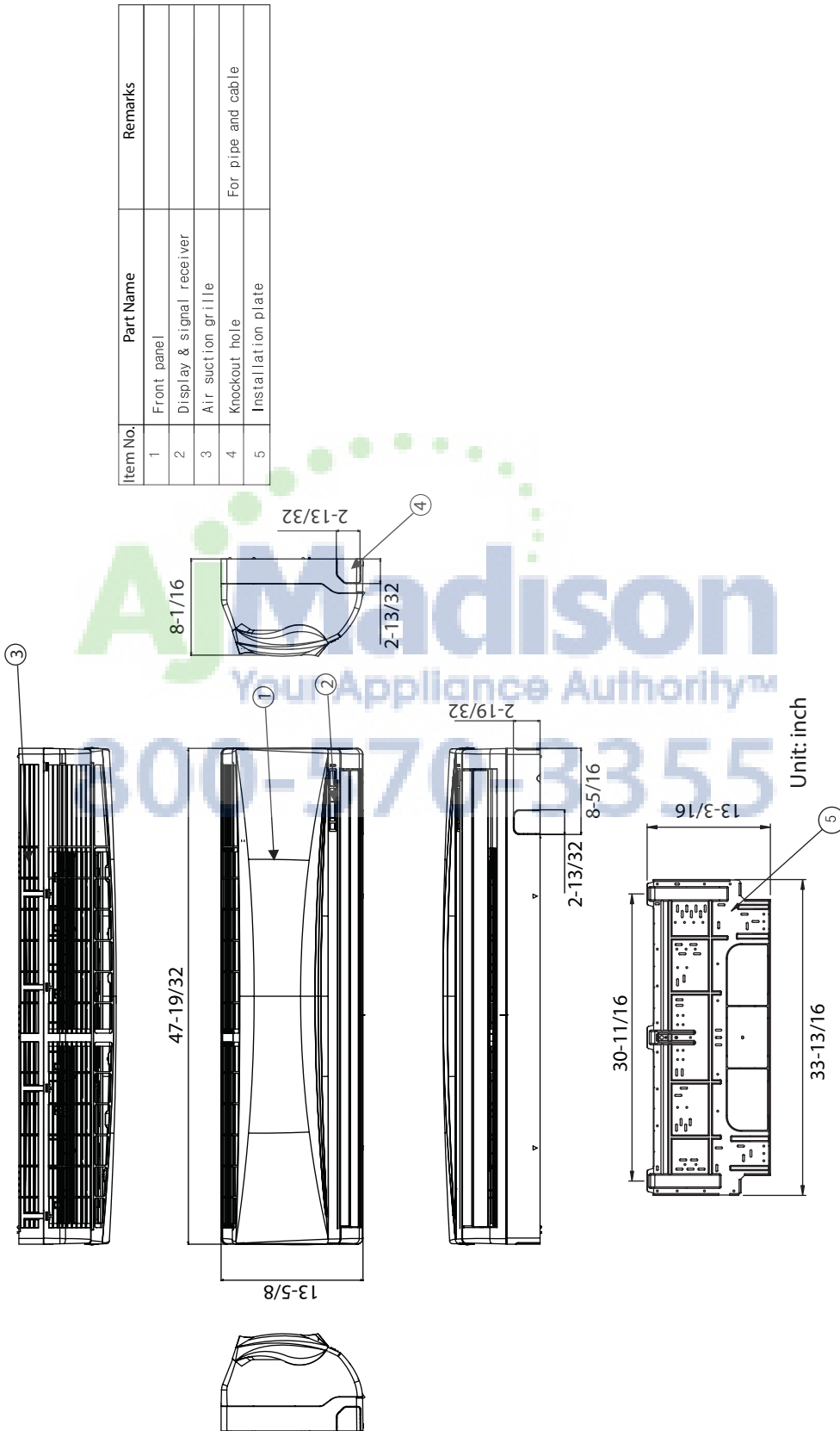

Item No.	Part Name	Remarks
1	Front panel	
2	Display & signal receiver	
3	Air suction grille	
4	Knockout hole	For pipe and cable
5	Installation plate	

Due to our policy of continuous product innovation, some specifications may change without notification.
 © LG Electronics U.S.A., Inc., Englewood Cliffs, NJ. All rights reserved. "LG" is a registered trademark of LG Corp.

INDOOR UNIT DIMENSIONS

LSN240HLV, LSN300HLV, LSN360HLV

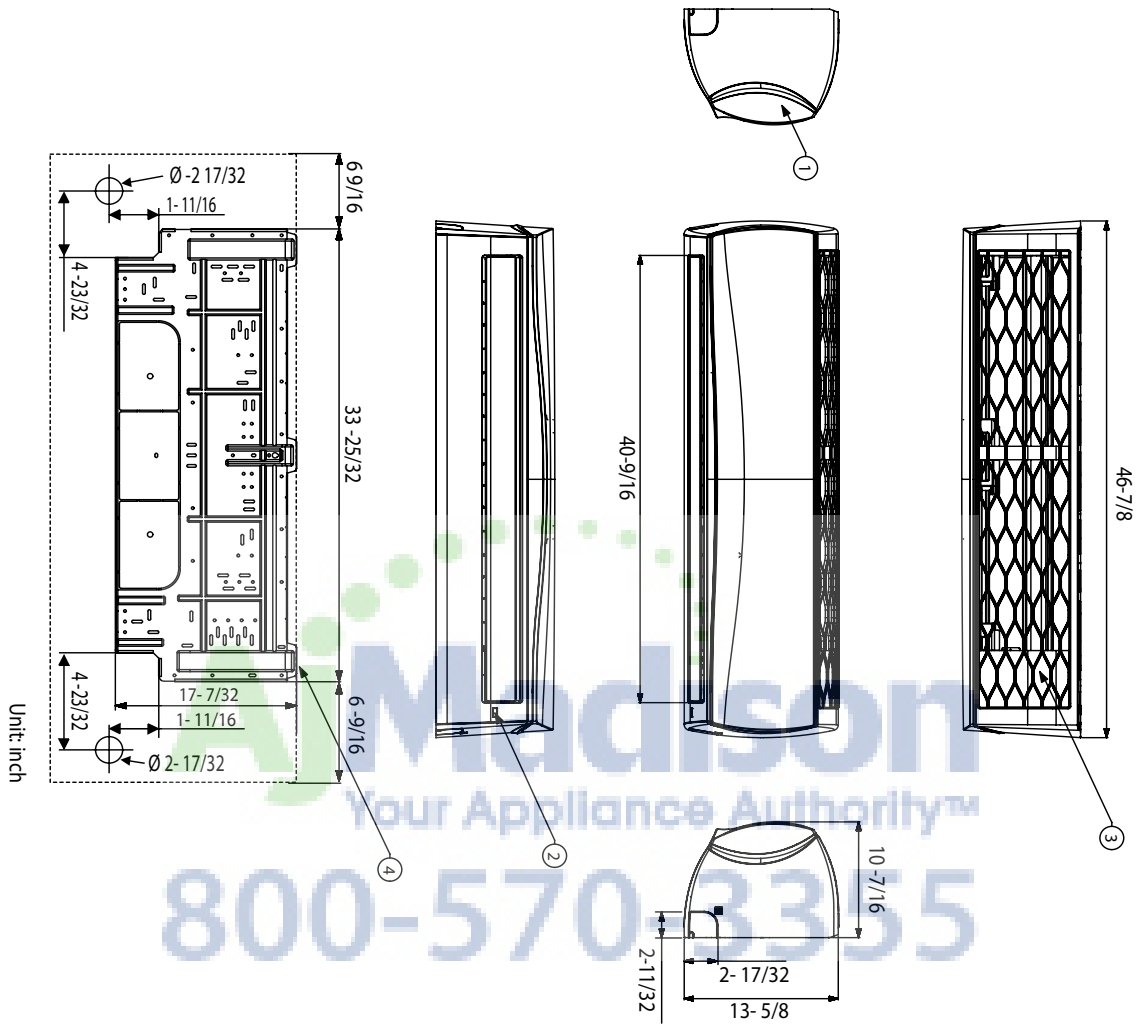

Item No.	Part Name	Remarks
1	Front Panel	
2	Display & Signal Receiver	
3	Air Suction Grille	
4	Installation Plate	

Product Data

Madison
Your Appliance Authority™
800-570-3355

OUTDOOR UNIT ACOUSTIC DATA

Figure 1: Outdoor Unit Sound Levels

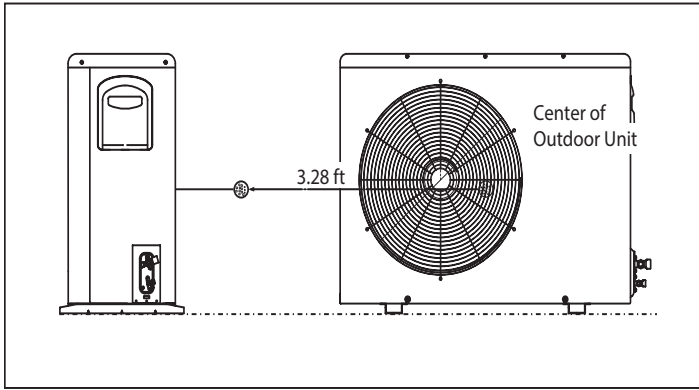

Table 12: Outdoor Unit Acoustic Data

Model	H
LSU091HSV3	45
LSU121HSV3	45
LSU181HSV3	53
LSU240HSV3	54
LSU307HV3	55
LSU360HV3	55
LSU240HLV	55
LSU300HLV	55
LSU360HLV	55

Figure 2: LSU091HSV3

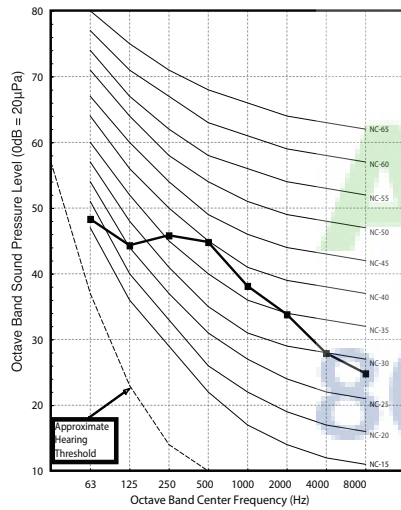

Figure 3: LSU121HSV3

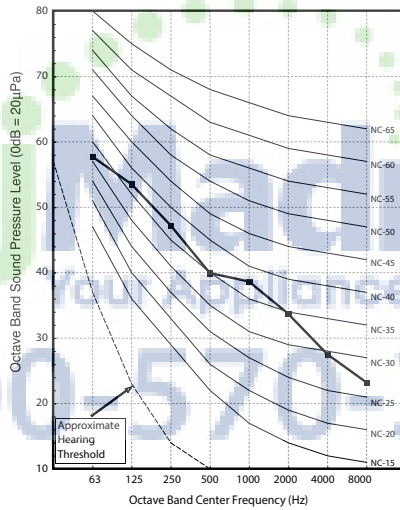

Figure 4: LSU181HSV3

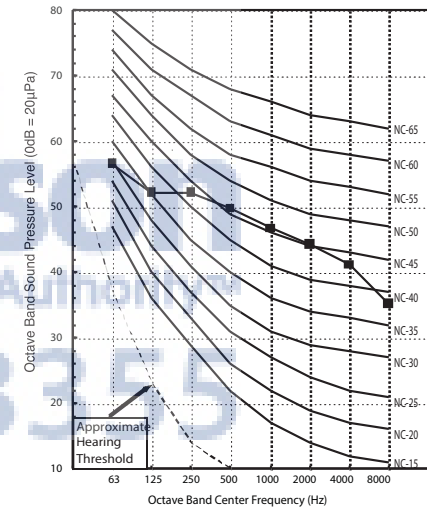

Figure 5: LSU240HSV3, LSU307HV3, LSU360HV3

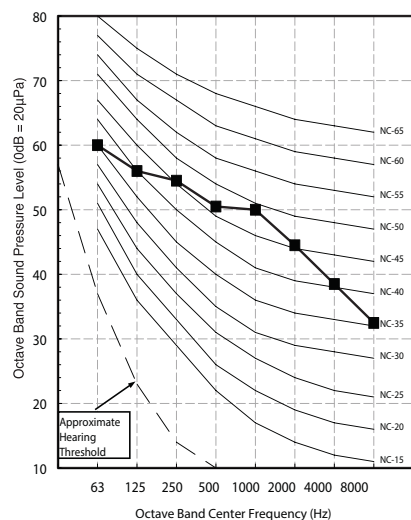
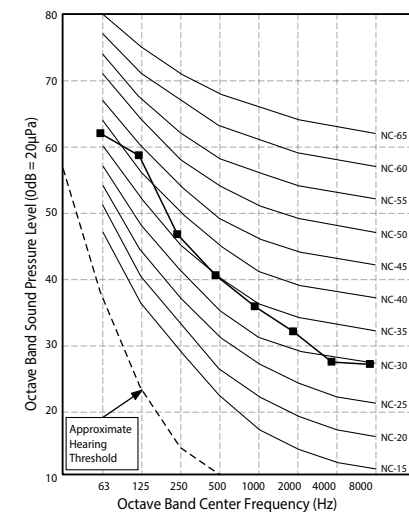

Figure 6: LSU240HLV, LSU300HLV, LSU360HLV



INDOOR UNIT ACOUSTIC DATA

Figure 7: Indoor Unit Sound Levels

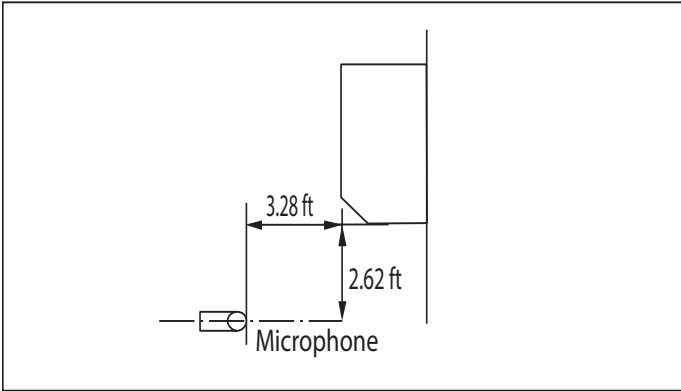

Table 13: Indoor Unit Acoustic Data

Model	H	M	L
LSN091HSV3	38	33	24
LSN121HSV3	39	33	24
LSN181HSV3	45	40	35
LSN240HSV3	46	43	39
LSN307HV3	49	44	39
LSN360HV3	49	44	39
LSN240HLV	49	44	40
LSN300HLV	49	44	40
LSN360HLV	49	44	40

Figure 8: LSN091HSV3

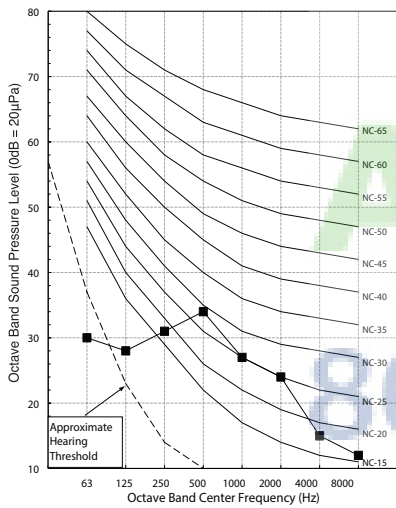

Figure 9: LSN121HSV3

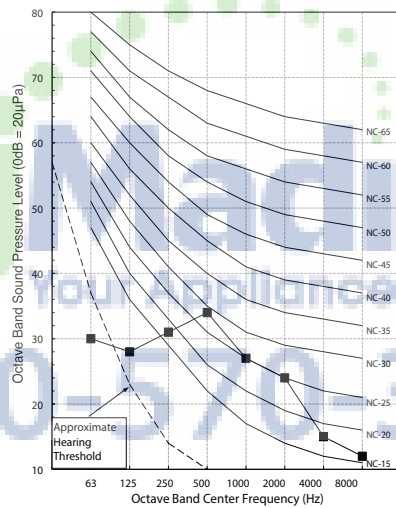

Figure 10: LSN181HSV3

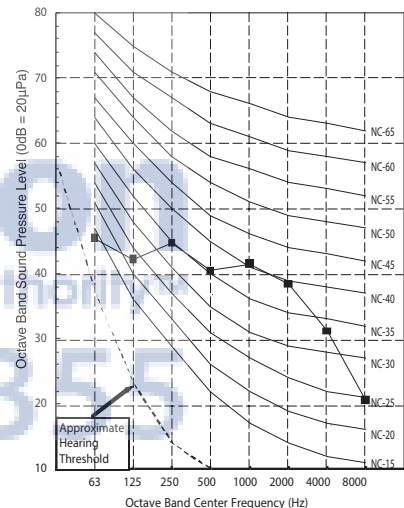

Figure 11: LSN240HSV3

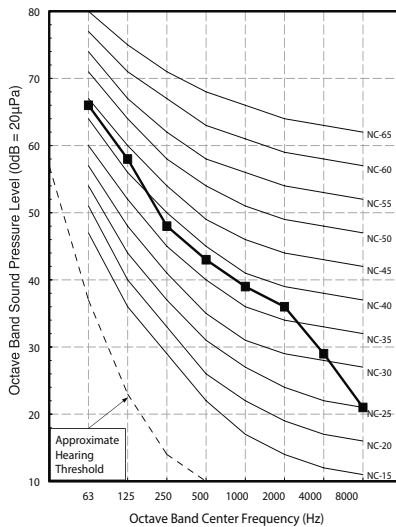

Figure 12: LSN307HSV3

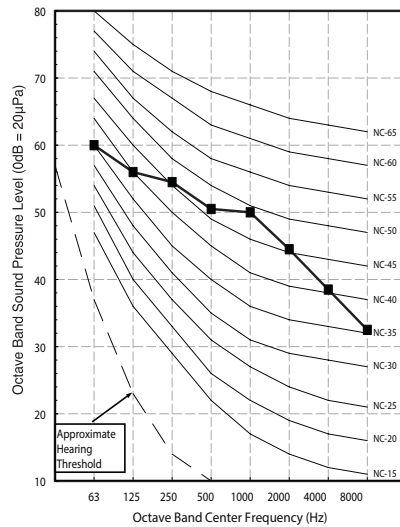
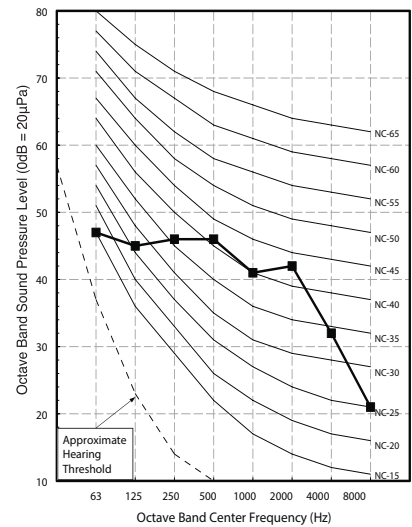

Figure 13: LSN360HSV3



INDOOR UNIT ACOUSTIC DATA

Figure 14: LSN240HLV

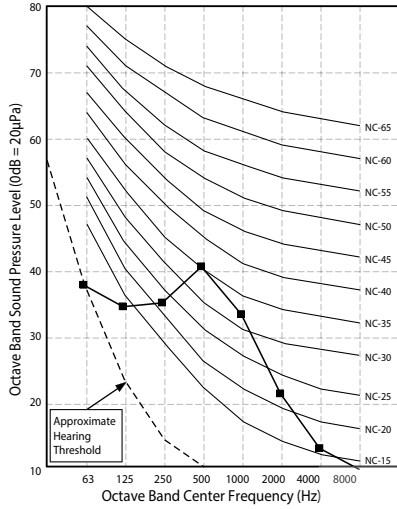

Figure 15: LSN300HLV

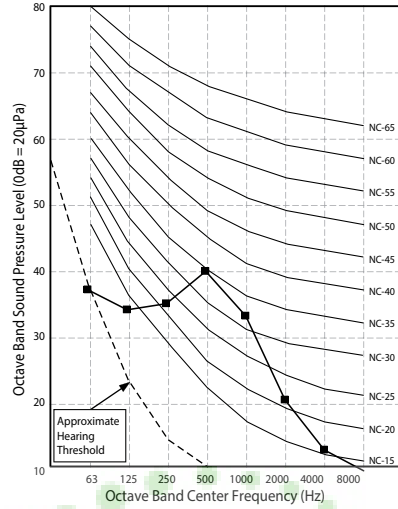
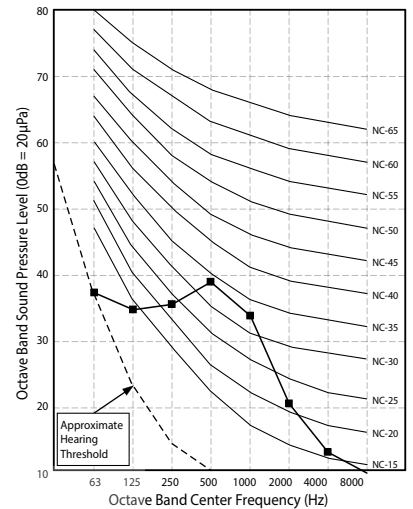
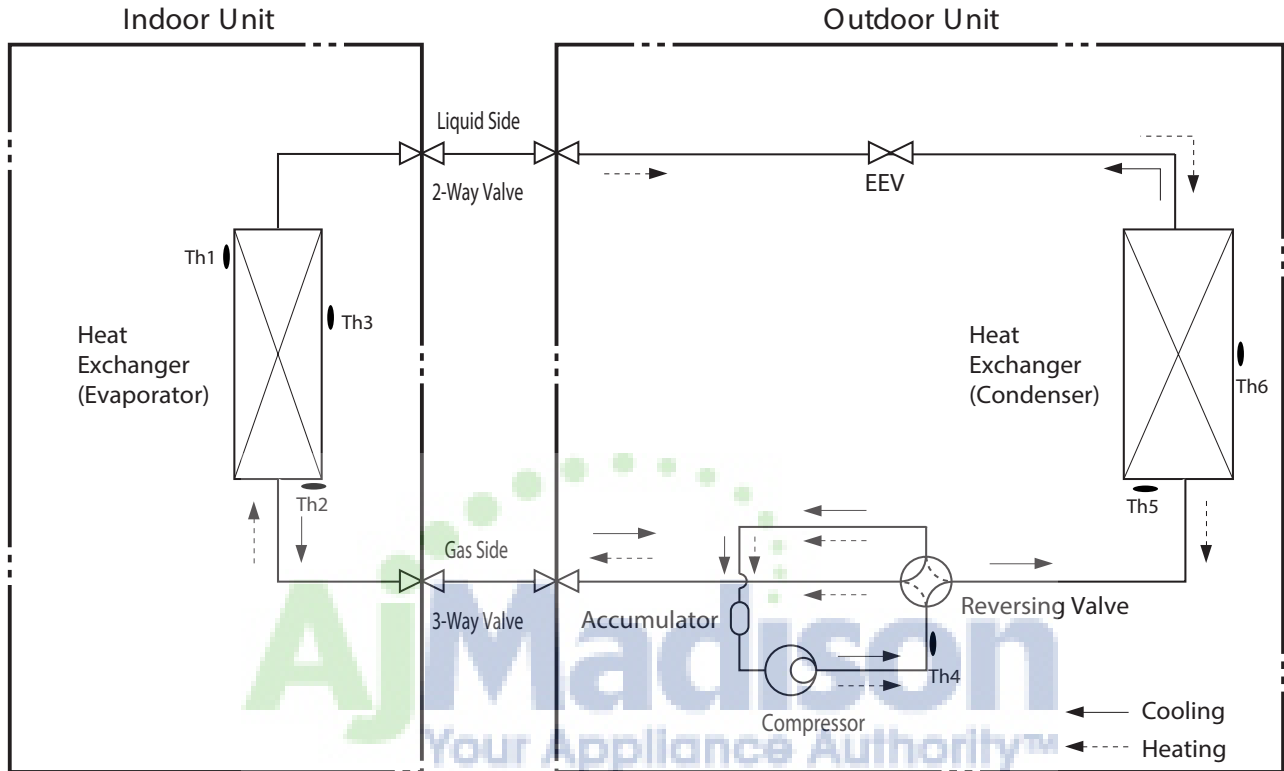

Figure 16: LSN360HLV



REFRIGERANT FLOW DIAGRAMS

LSU/LSN091HSV3, LSU/LSN121HSV3



EEV : Electronic Expansion Valve

800-570-3355

Product Data

LOC.	Description	PCB Connector
Th1	Suction air temperature thermistor	CN-TH1 (Indoor)
Th2	Water level sensor (optional)	CN-TH2 (Indoor)
Th3	Evaporating middle temperature thermistor	CN-TH3 (Indoor)
Th4	Discharge pipe temperature thermistor	CN-TH2 (Outdoor)
Th5	Condensing temperature thermistor	CN-TH1 (Outdoor)
Th6	Outdoor air temperature thermistor	

REFRIGERANT FLOW DIAGRAMS

LSU/LSN181HSV3

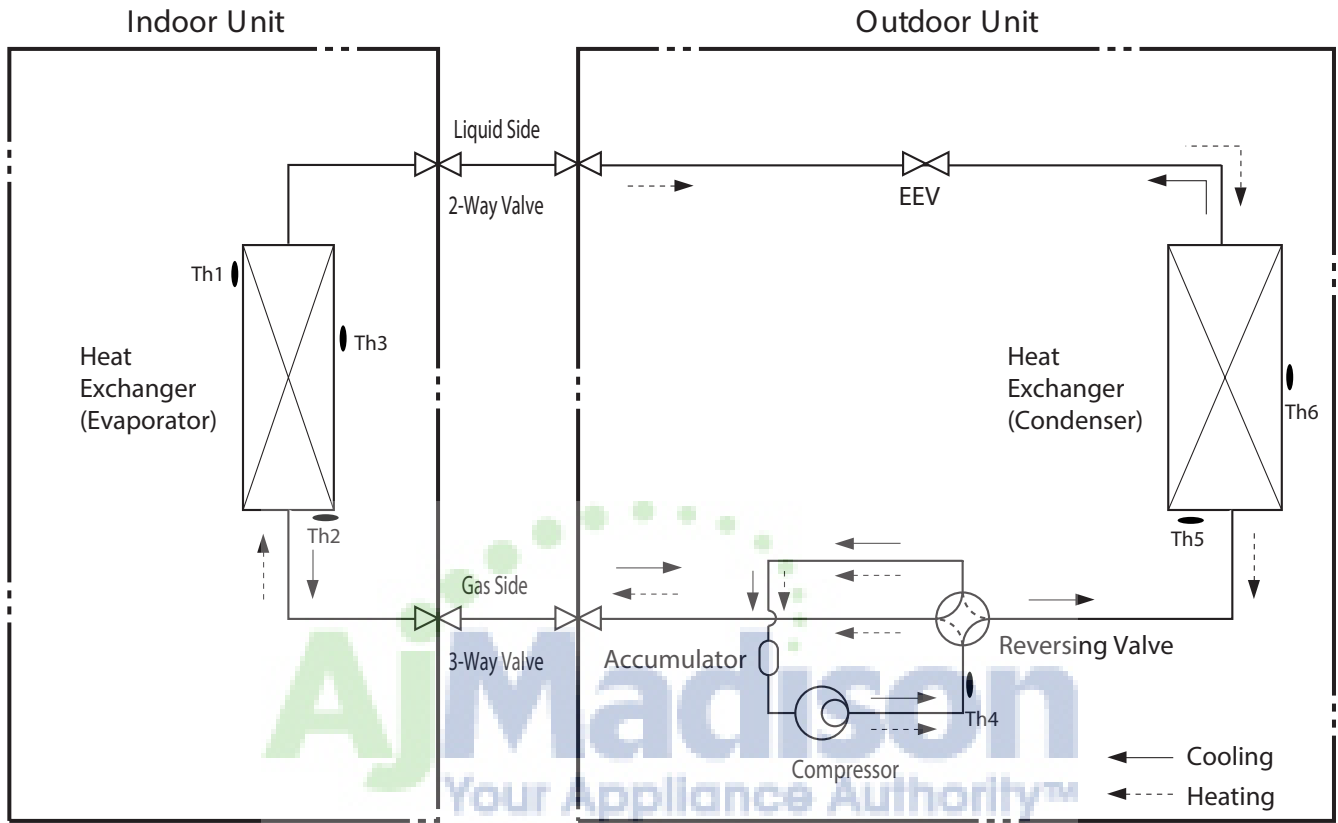

EEV : Electronic Expansion Valve

800-570-3355

LOC.	Description	PCB Connector
Th1	Suction air temperature thermistor	CN-TH1 (Indoor)
Th2	Water level sensor (optional)	
Th3	Evaporating outlet temperature thermistor + water level sensor	CN-TH2 (Indoor)
Th4	Evaporating middle temperature thermistor	CN-TH3 (Indoor)
Th5	Discharge pipe temperature thermistor	CN-TH3 (Outdoor)
Th6	Suction pipe temperature thermistor	
Th7	Condensing temperature thermistor	CN-TH2 (Outdoor)
Th8	Outdoor air temperature thermistor	CN-TH4 (Outdoor)
Th9	Condensing middle temperature thermistor	

REFRIGERANT FLOW DIAGRAMS

LSU/LSN240HSV3, LSU/LSN307HV3, LSU/LSN360HV3

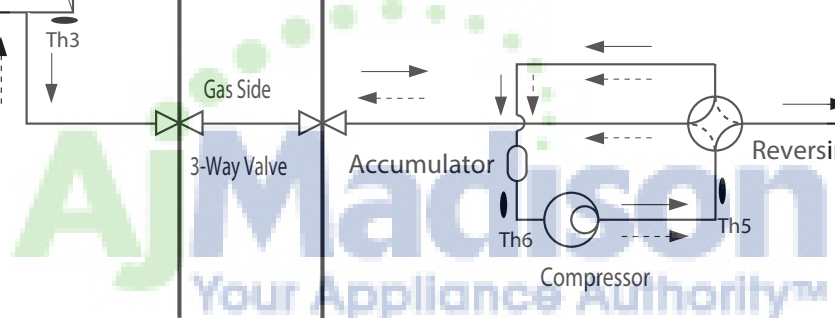
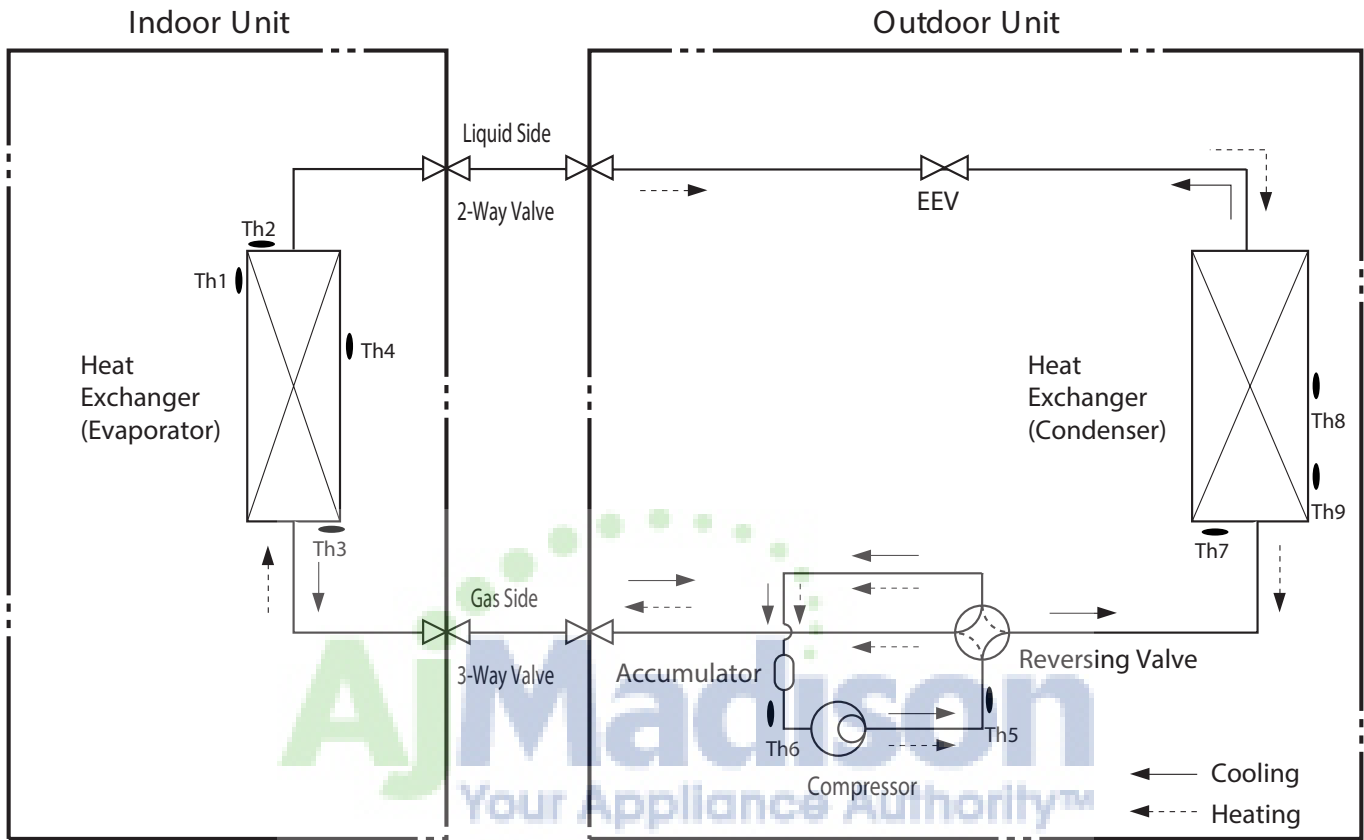

800-570-3355

Product Data

LOC.	Description	PCB Connector
Th1	Suction air temperature thermistor	CN-TH1 (Indoor)
Th2	Water level sensor (optional)	
Th3	Evaporating outlet temperature thermistor + water level sensor	CN-TH2 (Indoor)
Th4	Evaporating middle temperature thermistor	CN-TH3 (Indoor)
Th5	Discharge pipe temperature thermistor	CN-TH3 (Outdoor)
Th6	Suction pipe temperature thermistor	
Th7	Condensing temperature thermistor	CN-TH2 (Outdoor)
Th8	Outdoor air temperature thermistor	
Th9	Condensing middle temperature thermistor	CN-TH4 (Outdoor)

REFRIGERANT FLOW DIAGRAMS

LSU/LSN240HLV, LSU/LSN300HLV, LSU/LSN360HLV

Single Zone High Efficiency, Standard and Extended Pipe Wall Mount Engineering Manual

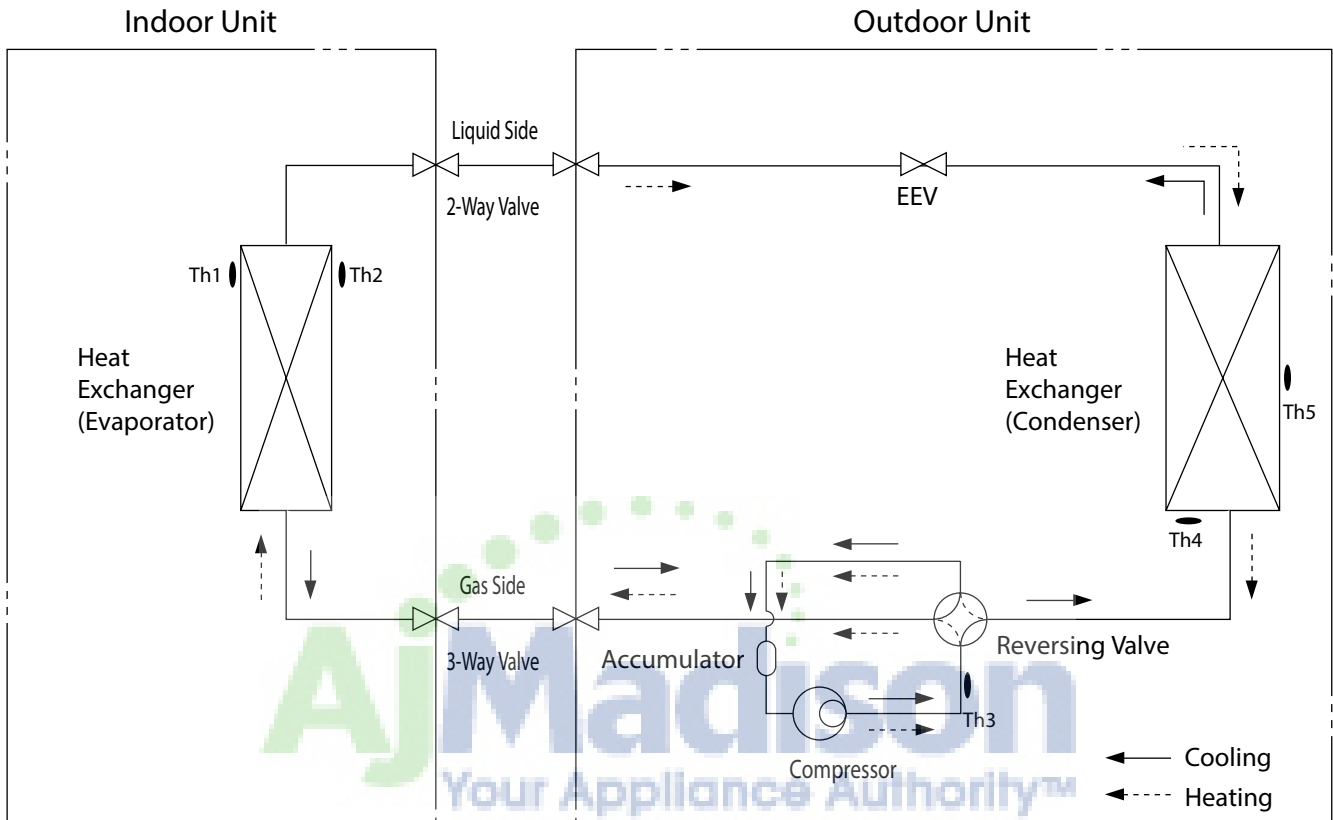

800-570-3355

LOC.	Description	PCB Connector
Th1	Suction air temperature thermistor	CN-TH1 (Indoor)
Th2	Evaporating middle temperature thermistor	CN-TH3 (Indoor)
Th3	Discharge pipe temperature thermistor	CN-TH3 (Outdoor)
Th4	Condensing temperature thermistor	CN-TH2 (Outdoor)
Th5	Outdoor air temperature thermistor	

WIRING DIAGRAMS

LSN091HSV3, LSN121HSV3

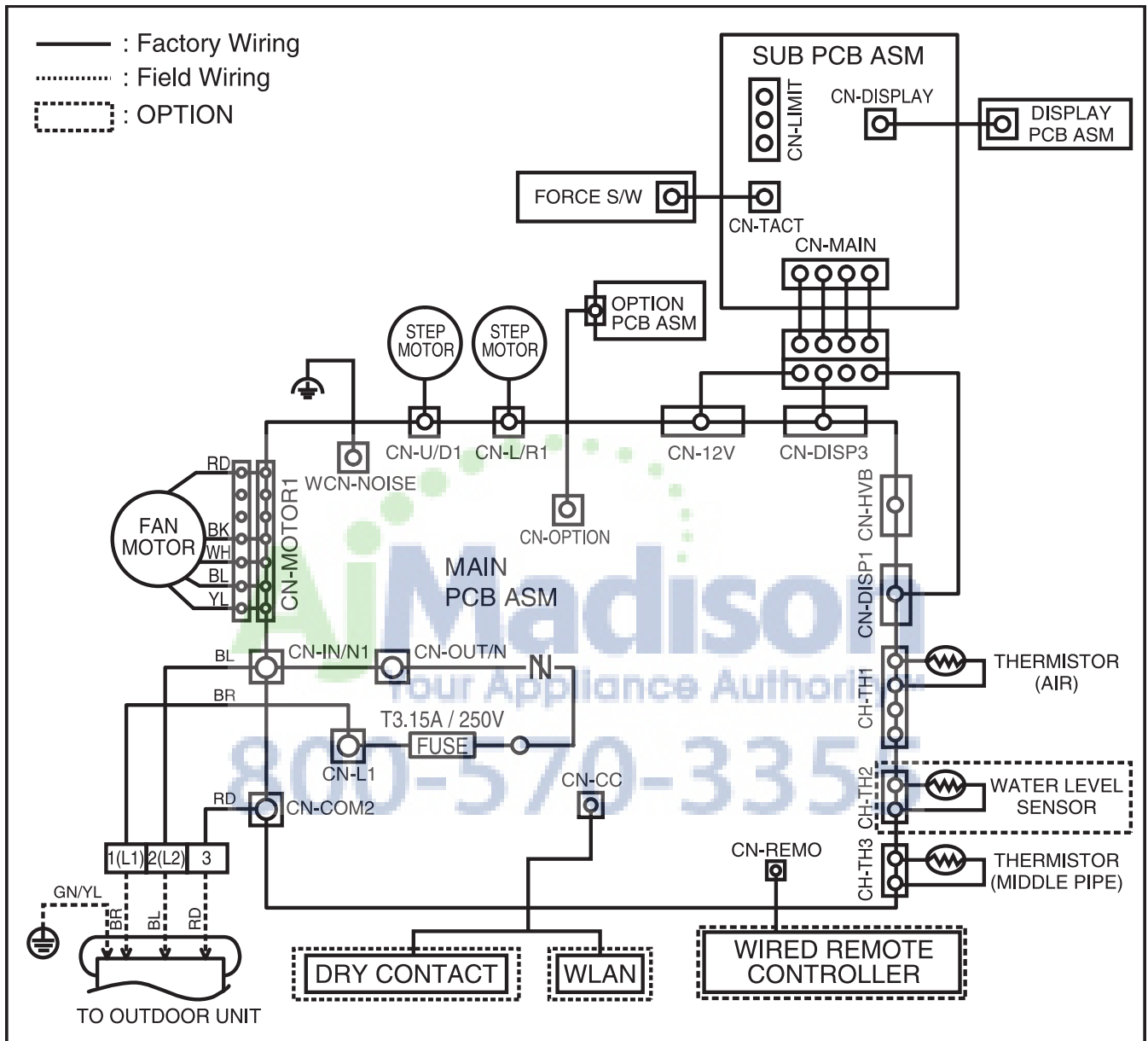

Product Data

WIRING DIAGRAMS

LSN181HSV3

Single Zone High Efficiency, Standard and Extended Pipe Wall Mount Engineering Manual

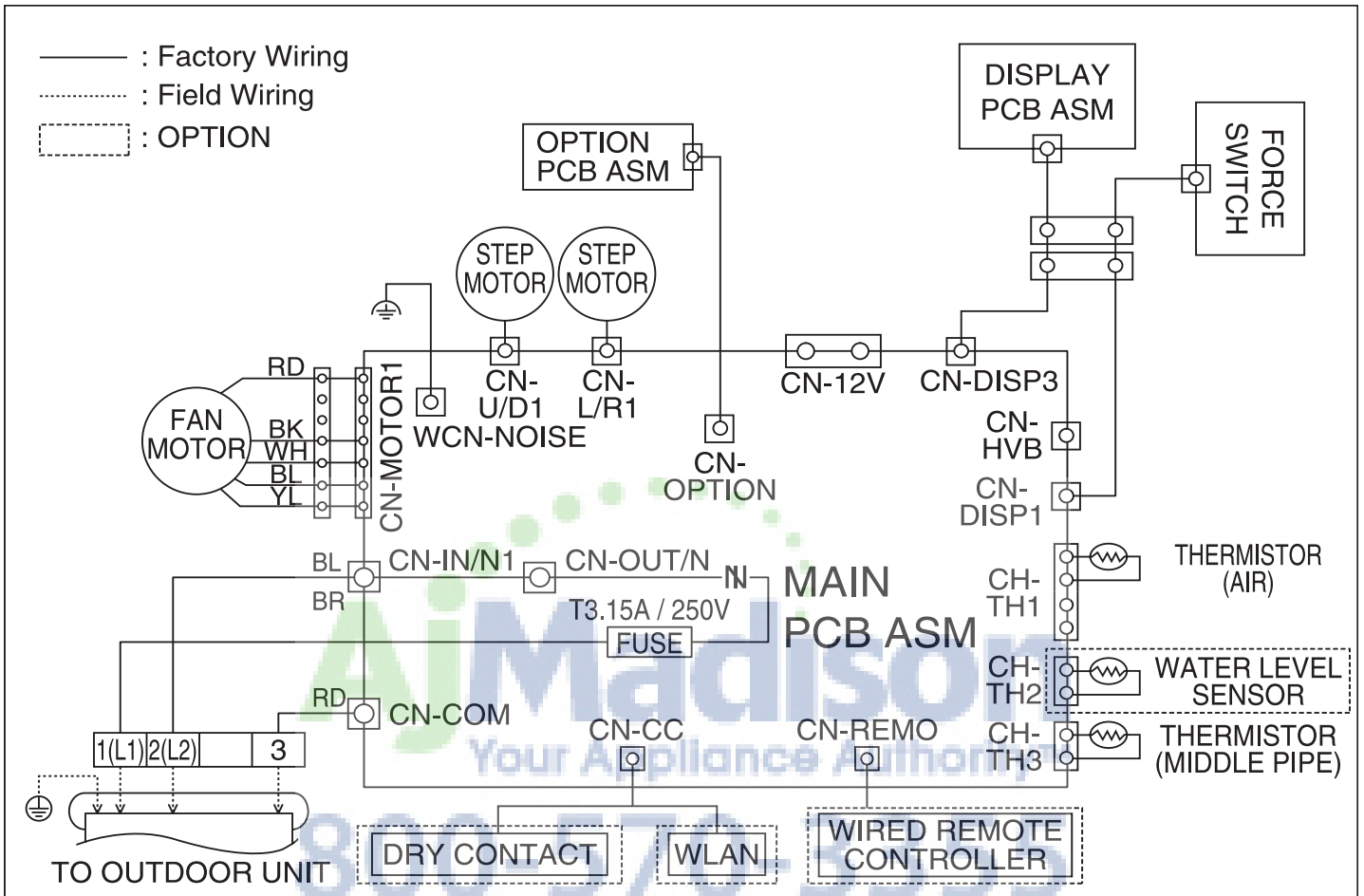

WIRING DIAGRAMS

LSN240HSV3, LSN307HV3, LSN360HV3

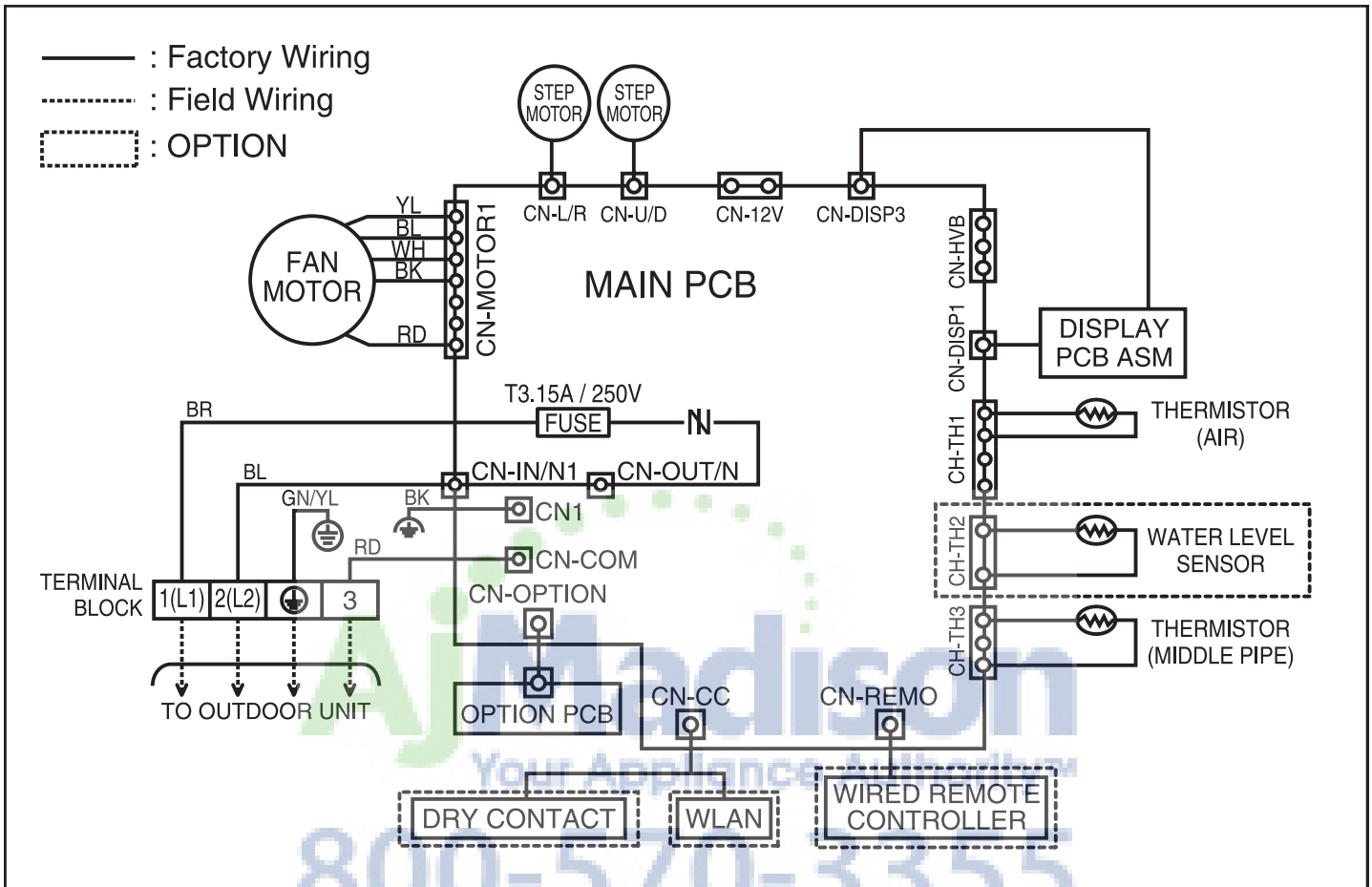

Product Data

800-570-3355

WIRING DIAGRAMS

LSN240HLV, LSN300HLV, LSN360HLV

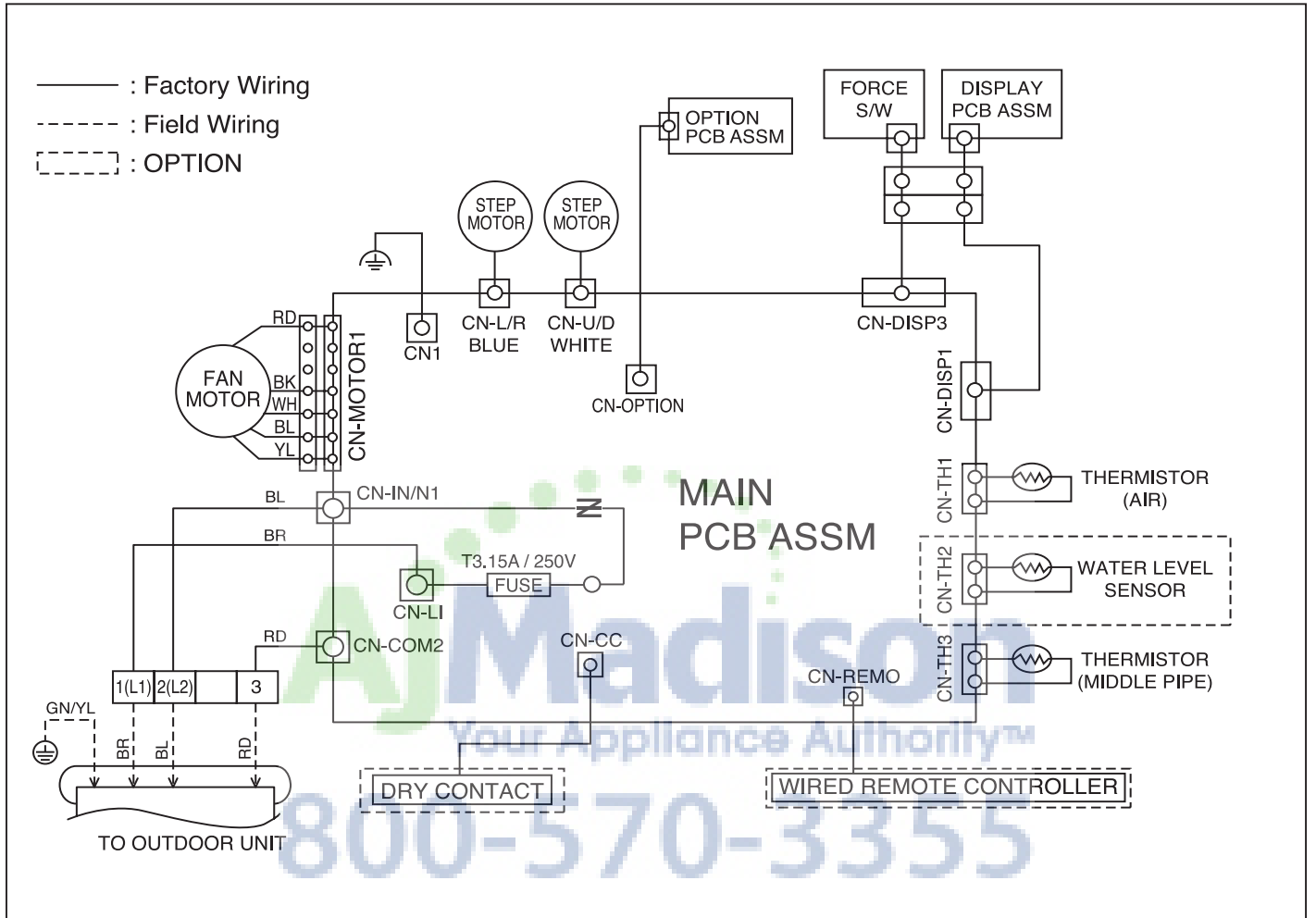

WIRING DIAGRAMS

LSU091HSV3, LSU121HSV3

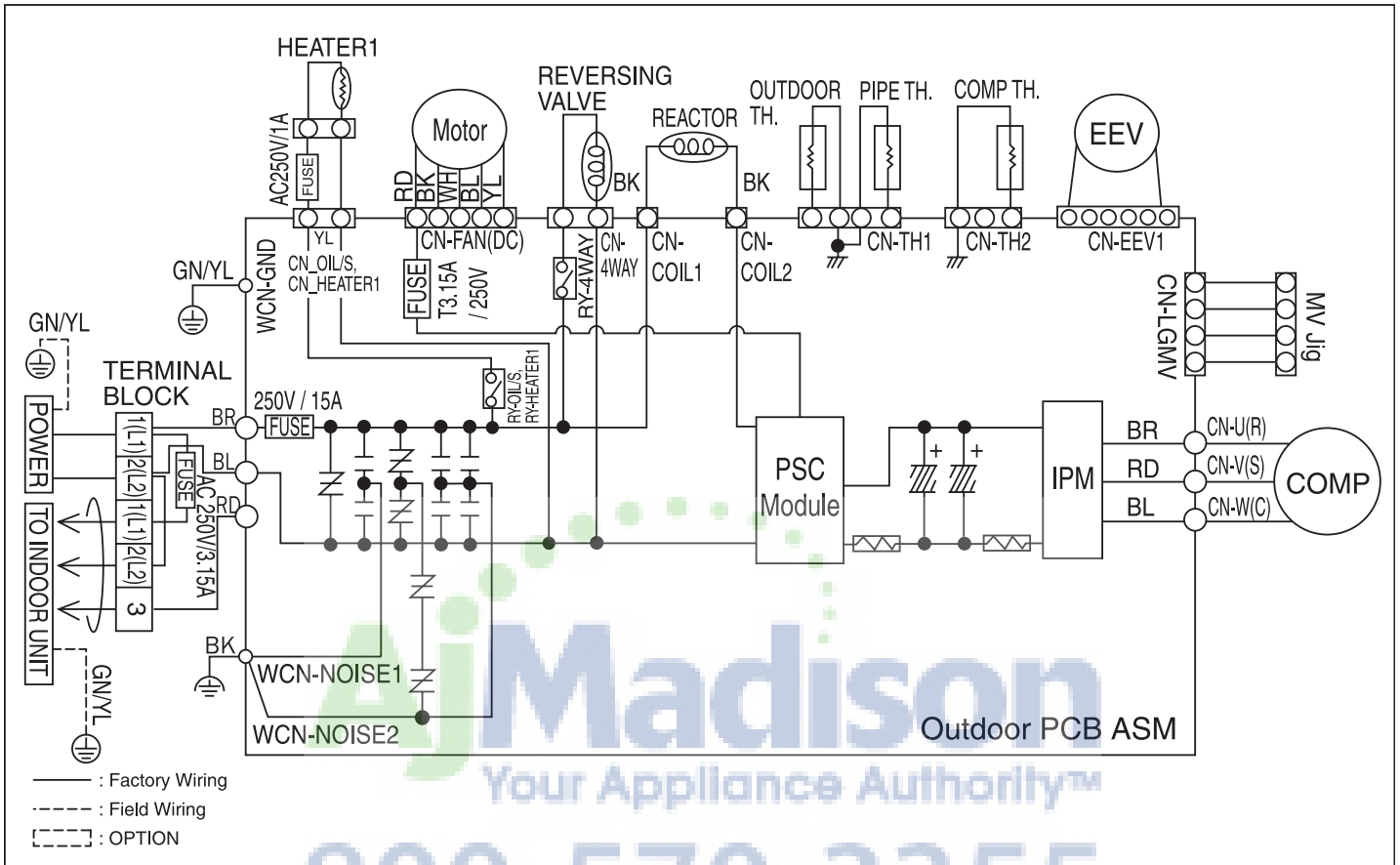

Product Data

Madison
 Your Appliance Authority™
 800-570-3355

WIRING DIAGRAMS

LSU181HSV3, LSU240HSV3, LSU307HV3, LSU360HV3

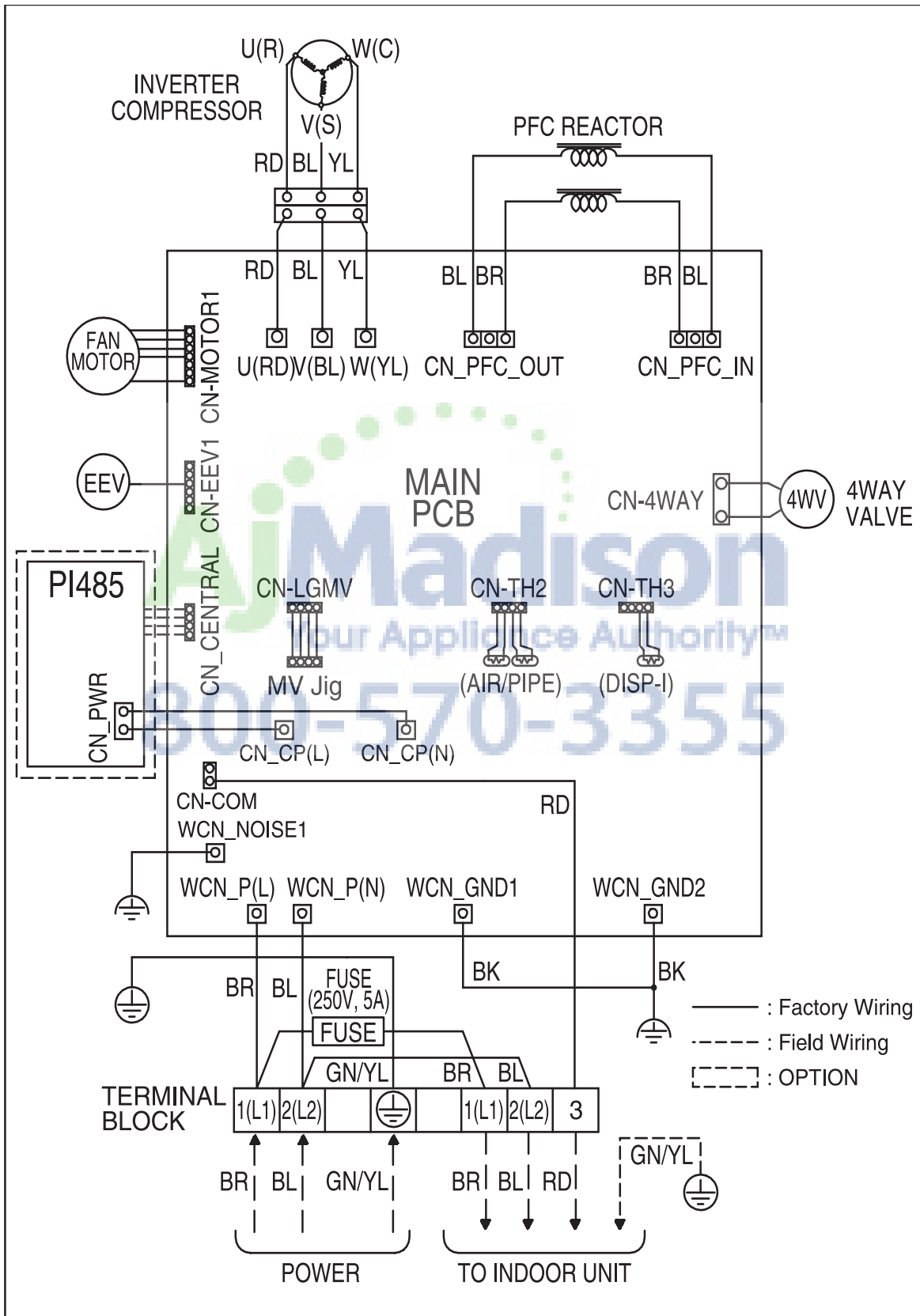

WIRING DIAGRAMS

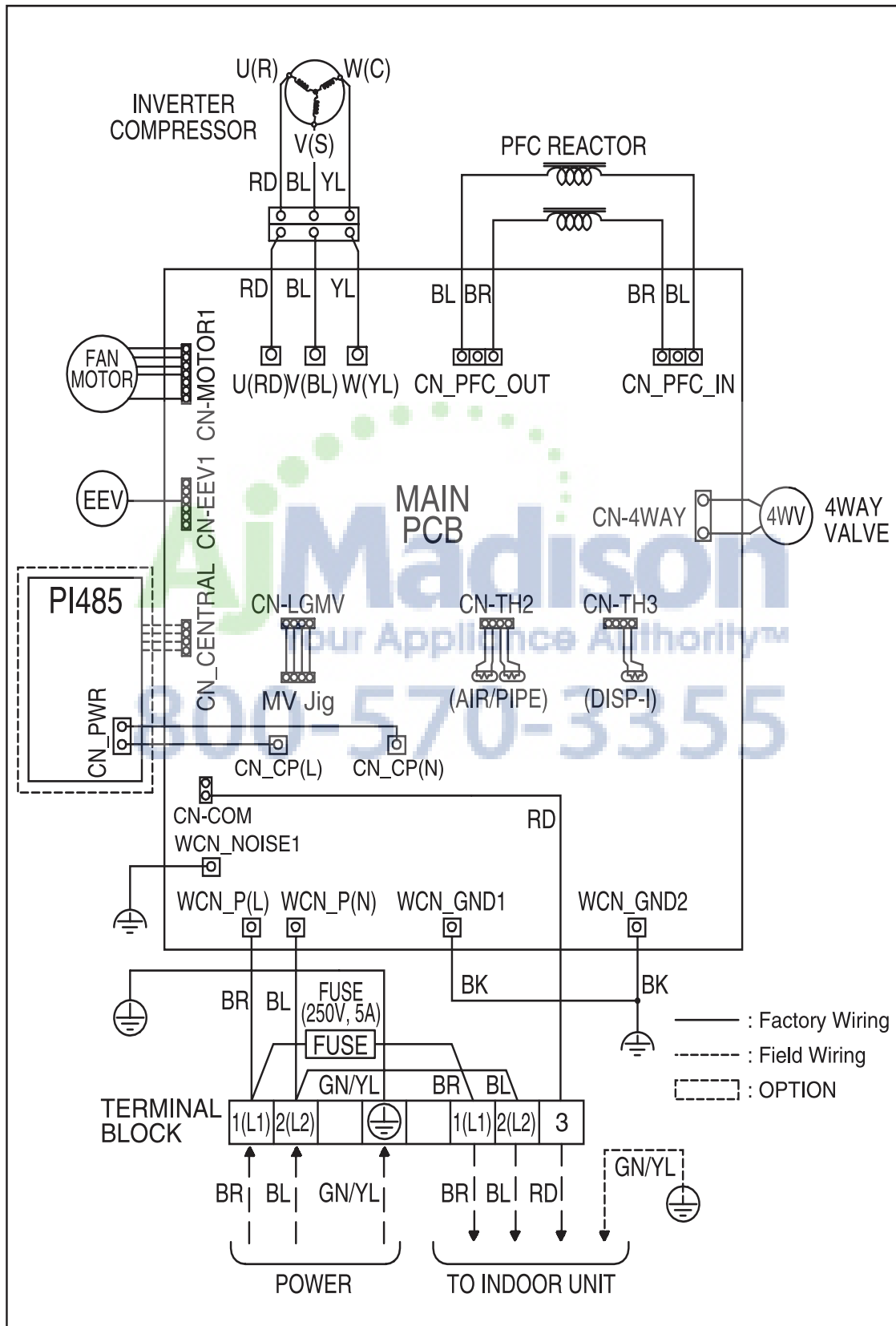

LSU240HLV, LSU300HLV, LSU360HLV



Product Data

ACCESSORIES

Table 14: Optional Zone Controllers

Zone Controller	Name	Model No.	Case Color	Max Wire Length (ft)	Description
	Simple Controller with mode selection	PQRCVCL0Q	Black	164	Allows control of indoor unit on/off, operation mode, fan speed, and temperature setpoint for up to 16 indoor units.
		PQRCVCL0QW	White		
	Simple Controller without mode selection	PQRCHCA0Q	Black	164	Allows control of indoor unit on/off, fan speed, and temperature setpoint for up to 16 indoor units.
		PQRCHCA0QW	White		
	LG Programmable Thermostat	PREMTB10U	White	164	Allows control of indoor unit on/off, operation mode, occupied and unoccupied temperature setpoints, fan speed, and airflow direction for up to 16 indoor units. Programmable schedule with 5 events per day with control of occupied/unoccupied, on/off, mode, setpoints and fan speed. Advanced functions include two setpoint autochangeover, minimum difference between setpoints, setback and timed override.



Before specifying or placing an order, refer to the V-Net Network Solution Engineering Product Data Book and review the detailed technical data provided to fully understand the capabilities and limitations of these devices.

Table 15: Summary Data—Zone Controller Communication Cables

Communication Cable	Name	Model No.	Wire Length (ft)	Description
	Wired Remote/Group Control Extension Cable	PZCWRC1	32	Increases the distance between a remote controller and an indoor unit or between indoor units in a control group.

Before specifying or placing an order, refer to the V-Net Network Solution Engineering Product Data Book and review the detailed technical data provided to fully understand the capabilities and limitations of these devices.

Table 16: Summary Data—Specialty Application Devices

Specialty Application Device	Name	Model No.	Connect to	Application	Binary Signals Input/Output	Description
	Dry Contact Unit 24 VAC	PQDSB1	Indoor Unit	On/Off, Run Status, Error Status	1/2	Enables the indoor unit to be controlled and monitored by third party controls using binary inputs and outputs.
	Dry Contact Unit for Communication	PQDSBCGCD0		On/Off, Mode, Controller Lock, Power Save, Run Status, Error Status	2/2	
	Dry Contact Unit for Thermostat	PQDSBNGCM1		On/Off, Thermo On/Off, Mode, Fan Speed, Run Status, Error Status	---	
	PI-485 V-net Control Integration Board ¹	PMNFP14A0	Outdoor Unit	---	---	Control integration to LG V-net controls (AC Smart Premium, ACP, BACnet, LonWorks, etc.)
	Digital Output (DO) Kit	PQNFP00T0	Comm Bus	On/Off	0/1	One 25 amp DPST normally open relay. Used with central controller to control third party device manually or by schedule.

¹The PI-485 is only available for use with models 18,000 Btu/h and larger.

Before specifying or placing an order, refer to the V-Net Network Solution Engineering Product Data Book and review the detailed technical data provided to fully understand the capabilities and limitations of these devices.

800-570-3355

ACCESSORIES

LG Monitoring View (LGMV) Diagnostic Software and Cable

(PRCTSL1 and PRCTFE1)

LGMV software allows the service technician or commissioning agent to connect a computer USB port to the outdoor unit main printed circuit board (PCB) using an accessory cable without the need for a separate interface device. The main screen for LGMV shall allow user to view the following real time data on one screen:

- Actual inverter compressor speed
- Target inverter compressor speed
- Actual outdoor fan speed
- Target outdoor unit fan speed
- Actual superheat
- Inverter compressor current value
- Outdoor air temperature
- Actual high pressure/saturation temperature
- Actual low pressure/saturation temperature
- Suction temperature
- Inverter compressor discharge temperature
- Outdoor coil pipe temperature
- Liquid line pipe temperature
- Inverter compressor operation indicator light
- Four-way reversing valve operation
- indicator light
- Pressure graph showing actual low pressure and actual high pressure levels
- Error code display
- Operating mode indicator
- Total number of connected indoor units (for multi zone systems)
- Communication indicator lights
- Unit error code
- Indoor unit capacity
- Indoor unit operating mode
- Indoor unit fan speed
- Indoor unit room temperature
- Indoor unit inlet pipe temperature
- Indoor unit outlet pipe temperature



Additional screens can be accessed by tabs on the main screen:

1. Cycleview: Graphic of internal components including:
 - Compressors showing actual speeds
 - EEVs
 - IDUs
 - Low and high pressures
 - Temperature and pressure sensors
 - Four-way reversing valve
 - Outdoor fans showing status and speeds
2. Setting: Converts metric values to imperial values.
3. Making Data: Recording of real time data to a separate file created to be stored on the user's computer.
4. Loading Data: Recorded data from a saved ".CSV" file can be loaded to create an LGMV session.
5. Electrical Data: The lower half of main screen is changed to show the following:
 - Inverter compressor
 - Amps
 - Volts
 - Power Hz
 - Inverter control board fan Hz

The software is available in a high version with all of the features listed above. The low version has all features as the high version without Target High Pressure and Target Low Pressure values shown on main screen.

In lieu of connecting to the ODU, user has the option to connect to IDU with the use of a USB to RS-485 connector kit. When connected through IDU, user will not be able to record data.

This software can be used to both commission new systems and troubleshoot existing systems. LGMV data can be recorded to a ".CSV" file and emailed to an LG representative to assist with diagnostic evaluations.

Recommended Minimum PC Configuration:

- CPU: Pentium® IV 1.6 GHz
- Operating System: Windows® NT/2000/XP/Vista
- Main Memory: 256 MB
- Hard Disk: 600 MB when operating
- Web Browser: Internet Explorer® 5.0

PERFORMANCE DATA

“Cooling Capacity Data” on page 44

“Heating Capacity Data” on page 47

AjMadison
Your Appliance Authority™

800-570-3355

PERFORMANCE DATA

Cooling Capacity

LSN/LSU091HSV3, LSN/LSU121HSV3, LSN/LSU181HSV3

Table 17: LSN091HSV3/LSU091HSV3 Cooling Capacities

Outdoor Air Temp. (°F DB)	Indoor Air Temperature (°F DB/ °F WB)																				
	64 / 53			68 / 57			72 / 61			77 / 64			80 / 67			86 / 72			90 / 75		
	TC	SHC	PI	TC	SHC	PI	TC	SHC	PI	TC	SHC	PI	TC	SHC	PI	TC	SHC	PI	TC	SHC	PI
14	5.51	4.83	0.29	5.92	5.19	0.30	6.33	5.56	0.31	6.75	5.92	0.32	6.94	6.08	0.33	7.57	6.64	0.34	7.99	7.00	0.35
23	5.92	5.00	0.29	6.36	5.38	0.30	6.80	5.75	0.31	7.24	6.13	0.31	7.45	6.30	0.32	8.13	6.88	0.34	8.57	7.25	0.35
59	7.10	5.37	0.33	7.63	5.78	0.34	8.16	6.18	0.35	8.69	6.58	0.36	8.94	6.77	0.37	9.75	7.39	0.39	10.29	7.79	0.40
70	8.10	6.60	0.49	8.64	7.04	0.50	9.18	7.47	0.52	9.54	7.77	0.53	9.81	7.99	0.55	10.53	8.57	0.57	11.25	9.16	0.59
75	8.00	6.62	0.50	8.54	7.07	0.52	9.08	7.52	0.53	9.45	7.83	0.55	9.72	8.05	0.57	10.40	8.61	0.59	11.16	9.24	0.61
80	7.79	6.56	0.52	8.33	7.02	0.54	8.87	7.47	0.56	9.27	7.81	0.57	9.63	8.11	0.59	10.26	8.64	0.62	10.98	9.25	0.63
85	7.58	6.59	0.56	8.12	7.06	0.58	8.66	7.52	0.60	9.09	7.90	0.61	9.45	8.21	0.63	10.13	8.80	0.66	10.82	9.40	0.68
90	7.37	6.63	0.58	7.91	7.12	0.60	8.45	7.60	0.62	8.91	8.01	0.64	9.27	8.34	0.66	9.99	8.99	0.69	10.60	9.53	0.71
95	7.15	6.66	0.60	7.68	7.15	0.62	8.22	7.65	0.64	8.75	8.15	0.66	9.00	8.38	0.68	9.83	9.15	0.71	10.36	9.65	0.73
100	6.96	6.55	0.61	7.50	7.05	0.63	8.03	7.56	0.65	8.57	8.06	0.67	8.88	8.36	0.69	9.64	9.07	0.72	10.17	9.57	0.74
105	6.77	6.44	0.62	7.31	6.95	0.64	7.84	7.46	0.66	8.38	7.97	0.68	8.77	8.34	0.70	9.45	8.99	0.73	9.99	9.50	0.75
110	6.59	6.38	0.63	7.12	6.90	0.65	7.66	7.42	0.67	8.19	7.94	0.69	8.58	8.31	0.71	9.26	8.98	0.74	9.80	9.49	0.76
115	6.40	6.26	0.64	6.94	6.79	0.65	7.47	7.31	0.68	8.01	7.83	0.70	8.39	8.21	0.72	9.08	8.88	0.75	9.61	9.41	0.77
118	6.21	6.12	0.64	6.75	6.65	0.66	7.20	7.10	0.68	7.74	7.63	0.70	8.10	7.98	0.72	8.78	8.65	0.75	9.27	9.14	0.78
122	5.92	5.84	0.64	6.42	6.35	0.66	6.93	6.85	0.68	7.44	7.35	0.71	7.80	7.71	0.73	8.45	8.35	0.76	8.96	8.85	0.78

Table 18: LSN121HSV3/LSU121HSV3 Cooling Capacities

Outdoor Air Temp. (°F DB)	Indoor Air Temperature (°F DB/ °F WB)																				
	64 / 53			68 / 57			72 / 61			77 / 64			80 / 67			86 / 72			90 / 75		
	TC	SHC	PI	TC	SHC	PI	TC	SHC	PI	TC	SHC	PI	TC	SHC	PI	TC	SHC	PI	TC	SHC	PI
14	6.86	6.01	0.38	7.37	6.46	0.39	7.88	6.91	0.40	8.40	7.36	0.42	8.63	7.57	0.43	9.42	8.26	0.45	9.94	8.71	0.46
23	7.36	6.23	0.38	7.91	6.69	0.39	8.46	7.16	0.40	9.01	7.63	0.41	9.27	7.84	0.43	10.12	8.56	0.44	10.67	9.03	0.46
59	8.83	6.69	0.44	9.49	7.19	0.45	10.16	7.69	0.46	10.82	8.19	0.48	11.12	8.42	0.49	12.14	9.19	0.51	12.80	9.69	0.53
70	10.08	8.21	0.64	10.75	8.75	0.66	11.42	9.30	0.68	11.87	9.67	0.70	12.21	9.94	0.73	13.10	10.67	0.76	14.00	11.40	0.78
75	9.95	8.24	0.66	10.63	8.80	0.68	11.30	9.36	0.70	11.76	9.74	0.72	12.10	10.02	0.75	12.94	10.71	0.78	13.89	11.50	0.80
80	9.69	8.16	0.69	10.36	8.73	0.71	11.04	9.30	0.73	11.54	9.72	0.76	11.98	10.10	0.78	12.77	10.76	0.81	13.66	11.51	0.84
85	9.43	8.20	0.74	10.10	8.78	0.76	10.77	9.36	0.78	11.31	9.83	0.81	11.76	10.22	0.83	12.60	10.95	0.87	13.46	11.70	0.89
90	9.17	8.25	0.77	9.84	8.85	0.79	10.51	9.46	0.82	11.09	9.97	0.84	11.54	10.38	0.87	12.43	11.18	0.90	13.19	11.87	0.93
95	8.90	8.28	0.79	9.56	8.90	0.82	10.23	9.52	0.84	10.89	10.14	0.87	11.20	10.43	0.90	12.23	11.38	0.93	12.89	12.00	0.96
100	8.66	8.15	0.81	9.33	8.78	0.83	10.00	9.40	0.86	10.66	10.03	0.88	11.05	10.40	0.91	11.99	11.29	0.95	12.66	11.91	0.98
105	8.43	8.02	0.82	9.10	8.65	0.85	9.76	9.28	0.87	10.43	9.92	0.90	10.91	10.37	0.93	11.76	11.18	0.96	12.43	11.82	0.99
110	8.20	7.94	0.83	8.86	8.59	0.85	9.53	9.23	0.88	10.20	9.88	0.91	10.68	10.35	0.94	11.53	11.17	0.97	12.19	11.82	1.00
115	7.96	7.79	0.84	8.63	8.45	0.86	9.30	9.10	0.89	9.96	9.75	0.92	10.44	10.22	0.95	11.30	11.05	0.98	11.96	11.70	1.01
118	7.73	7.62	0.84	8.40	8.28	0.87	8.96	8.83	0.90	9.63	9.49	0.93	10.08	9.94	0.95	10.92	10.76	0.99	11.54	11.37	1.02
122	7.36	7.27	0.85	7.99	7.90	0.87	8.62	8.52	0.90	9.25	9.14	0.93	9.71	9.59	0.96	10.51	10.39	1.00	11.14	11.01	1.03

Table 19: LSN181HSV3/LSU181HSV3 Cooling Capacities

Outdoor Air Temp. (°F DB)	Indoor Air Temperature (°F DB/ °F WB)																				
	64 / 53			68 / 57			72 / 61			77 / 64			80 / 67			86 / 72			90 / 75		
	TC	SHC	PI	TC	SHC	PI	TC	SHC	PI	TC	SHC	PI	TC	SHC	PI	TC	SHC	PI	TC	SHC	PI
14	11.14	9.77	0.61	11.98	10.50	0.63	12.81	11.23	0.65	13.64	11.97	0.67	14.03	12.30	0.69	15.31	13.43	0.72	16.15	14.16	0.74
23	11.96	10.12	0.61	12.86	10.88	0.63	13.75	11.64	0.65	14.65	12.39	0.67	15.06	12.74	0.69	16.44	13.91	0.72	17.34	14.67	0.74
59	14.35	10.87	0.70	15.43	11.68	0.73	16.50	12.50	0.75	17.58	13.31	0.77	18.07	13.68	0.80	19.73	14.94	0.83	20.80	15.75	0.85
70	16.38	13.34	1.04	17.47	14.23	1.07	18.56	15.12	1.10	19.29	15.71	1.14	19.84	16.15	1.17	21.29	17.34	1.22	22.75	18.52	1.26
75	16.17	13.39	1.07	17.27	14.30	1.10	18.36	15.21	1.14	19.11	15.83	1.17	19.66	16.28	1.21	21.02	17.41	1.25	22.57	18.69	1.29
80	15.75	13.27	1.11	16.84	14.19	1.15	17.93	15.11	1.18	18.75	15.79	1.22	19.47	16.41	1.26	20.75	17.48	1.31	22.20	18.70	1.35
85	15.33	13.32	1.19	16.42	14.27	1.23	17.51	15.22	1.27	18.38	15.97	1.31	19.11	16.61	1.35	20.48	17.79	1.40	21.87	19.01	1.44
90	14.91	13.41	1.24	16.00	14.39	1.28	17.08	15.37	1.32	18.02	16.21	1.36	18.75	16.86	1.40	20.20	18.17	1.46	21.44	19.28	1.50
95	14.46	13.46	1.28	15.54	14.47	1.32	16.62	15.48	1.36	17.70	16.48	1.40	18.20	16.95	1.45	19.87	18.50	1.50	20.95	19.51	1.55
100	14.08	13.25	1.30	15.16	14.26	1.34	16.24	15.28	1.38	17.32	16.30	1.43	17.96	16.90	1.47	19.49	18.34	1.53	20.57	19.36	1.58
105	13.70	13.03	1.32	14.78	14.06	1.36	15.86	15.09	1.41	16.95	16.12	1.45	17.73	16.86	1.50	19.11	18.17	1.56	20.19	19.20	1.60
110	13.32	12.91	1.34	14.40	13.96	1.38	15.49	15.00	1.42	16.57	16.05	1.47	17.35	16.81	1.51	18.73	18.15	1.57	19.82	19.20	1.62
115	12.94	12.66	1.35	14.02	13.72	1.39	15.11	14.78	1.44	16.19	15.84	1.48	16.97	16.61	1.53	18.35	17.96	1.59	19.44	19.02	1.64
118	12.56	12.38	1.36	13.65	13.45	1.41	14.56	14.35	1.45	15.65	15.43	1.49	16.38	16.14	1.54	17.75	17.49	1.60	18.75	18.48	1.65
122	11.96	11.82	1.37	12.99	12.83	1.41	14.01	13.84	1.46	15.04	14.86	1.50	15.78	15.59	1.55	17.09	16.88	1.61	18.11	17.89	1.66

DB: Dry Bulb Temperature (°F) WB: Wet Bulb Temperature (°F) TC: Total Capacity (kBtu/h)
 SHC: Sensible Capacity (kBtu/h) PI: Power Input (kW) (includes compressor, indoor fan motor and outdoor fan motor)
 1. All capacities are net, evaporator fan motor heat is deducted.
 2. Grey shading indicates reference data. When operating the unit at this temperature, these values can be different by discontinuous operation.

3. Direct interpolation is permissible. Do not extrapolate.
 Nominal capacity as rated: 0 ft. above sea level with 25 ft. of refrigerant piping.
 0 ft. level difference between outdoor and indoor units.
 Nominal cooling capacity rating obtained with air entering the indoor unit at 80°F dry bulb (DB) and 67°F wet bulb (WB), and outdoor ambient conditions of 95°F dry bulb (DB) and 75°F wet bulb (WB).



PERFORMANCE DATA

Cooling Capacity

LSN/LSU240HSV3, LSN/LSU307HV3, LSN/LSU360HV3

Table 20: LSN240HSV3/LSU240HSV3 Cooling Capacities

Outdoor Air Temp. (°F DB)	Indoor Air Temperature (°F DB/ °F WB)																				
	64 / 53			68 / 57			72 / 61			77 / 64			80 / 67			86 / 72			90 / 75		
	TC	SHC	PI	TC	SHC	PI	TC	SHC	PI	TC	SHC	PI	TC	SHC	PI	TC	SHC	PI	TC	SHC	PI
14	13.47	11.81	0.75	14.48	12.69	0.77	15.49	13.58	0.79	16.49	14.46	0.82	16.96	14.87	0.84	18.51	16.23	0.88	19.52	17.12	0.90
23	14.46	12.23	0.74	15.54	13.15	0.77	16.62	14.06	0.79	17.71	14.98	0.81	18.20	15.40	0.84	19.87	16.81	0.87	20.96	17.73	0.90
59	17.35	13.14	0.86	18.65	14.12	0.88	19.95	15.11	0.91	21.25	16.09	0.94	21.84	16.54	0.97	23.85	18.06	1.01	25.14	19.04	1.04
70	19.80	16.12	1.26	21.12	17.20	1.30	22.44	18.27	1.34	23.32	18.99	1.38	23.98	19.53	1.43	25.74	20.96	1.48	27.50	22.39	1.53
75	19.55	16.19	1.30	20.87	17.29	1.34	22.20	18.38	1.38	23.10	19.13	1.42	23.76	19.68	1.47	25.41	21.04	1.53	27.28	22.59	1.57
80	19.03	16.04	1.36	20.36	17.15	1.40	21.68	18.26	1.44	22.66	19.09	1.49	23.54	19.83	1.53	25.08	21.13	1.59	26.84	22.61	1.64
85	18.53	16.10	1.45	19.85	17.25	1.49	21.16	18.39	1.54	22.22	19.31	1.59	23.10	20.07	1.64	24.75	21.51	1.70	26.44	22.98	1.75
90	18.02	16.21	1.51	19.34	17.39	1.56	20.65	18.58	1.61	21.78	19.59	1.66	22.66	20.38	1.71	24.42	21.97	1.78	25.91	23.31	1.83
95	17.47	16.27	1.56	18.78	17.49	1.61	20.09	18.71	1.66	21.40	19.93	1.71	22.00	20.48	1.76	24.02	22.36	1.83	25.33	23.58	1.89
100	17.02	16.01	1.58	18.33	17.24	1.63	19.63	18.47	1.68	20.94	19.70	1.74	21.71	20.43	1.79	23.56	22.17	1.86	24.87	23.40	1.92
105	16.56	15.75	1.61	17.87	16.99	1.66	19.18	18.24	1.71	20.48	19.48	1.76	21.43	20.38	1.82	23.10	21.97	1.89	24.41	23.21	1.95
110	16.10	15.60	1.63	17.41	16.87	1.68	18.72	18.14	1.73	20.03	19.40	1.78	20.97	20.32	1.84	22.64	21.94	1.91	23.95	23.21	1.97
115	15.64	15.31	1.64	16.95	16.59	1.69	18.26	17.87	1.75	19.57	19.15	1.80	20.52	20.07	1.86	22.19	21.71	1.93	23.50	22.99	1.99
118	15.18	14.96	1.66	16.50	16.26	1.71	17.60	17.35	1.76	18.92	18.65	1.82	19.80	19.52	1.87	21.45	21.14	1.95	22.66	22.33	2.01
122	14.46	14.29	1.67	15.70	15.51	1.72	16.94	16.73	1.77	18.18	17.96	1.83	19.07	18.84	1.88	20.65	20.41	1.96	21.89	21.63	2.02

Table 21: LSN307HV3/LSU307HV3 Cooling Capacities

Outdoor Air Temp. (°F DB)	Indoor Air Temperature (°F DB/ °F WB)																				
	64 / 53			68 / 57			72 / 61			77 / 64			80 / 67			86 / 72			90 / 75		
	TC	SHC	PI	TC	SHC	PI	TC	SHC	PI	TC	SHC	PI	TC	SHC	PI	TC	SHC	PI	TC	SHC	PI
14	18.37	16.11	1.27	19.74	17.31	1.31	21.12	18.52	1.35	22.49	19.72	1.39	23.12	20.28	1.44	25.24	22.14	1.50	26.62	23.34	1.54
23	19.72	16.68	1.27	21.19	17.93	1.31	22.67	19.18	1.35	24.15	20.43	1.39	24.82	21.00	1.43	27.10	22.93	1.49	28.58	24.18	1.53
59	23.66	17.92	1.46	25.43	19.26	1.51	27.20	20.60	1.55	28.97	21.94	1.60	29.79	22.56	1.65	32.52	24.62	1.72	34.29	25.97	1.77
70	27.00	21.99	2.15	28.80	23.45	2.22	30.60	24.92	2.29	31.80	25.89	2.36	32.70	26.63	2.43	35.10	28.58	2.53	37.50	30.53	2.60
75	26.65	22.07	2.21	28.46	23.57	2.28	30.27	25.07	2.35	31.50	26.09	2.43	32.40	26.83	2.50	34.65	28.70	2.60	37.20	30.81	2.68
80	25.96	21.87	2.31	27.76	23.38	2.38	29.56	24.90	2.46	30.90	26.03	2.53	32.10	27.04	2.61	34.20	28.81	2.71	36.60	30.83	2.80
85	25.27	21.96	2.47	27.06	23.52	2.55	28.86	25.08	2.63	30.30	26.33	2.71	31.50	27.37	2.79	33.75	29.33	2.90	36.05	31.33	2.99
90	24.57	22.10	2.58	26.37	23.72	2.66	28.16	25.33	2.74	29.70	26.71	2.82	30.90	27.79	2.91	33.30	29.95	3.03	35.33	31.78	3.12
95	23.83	22.19	2.66	25.61	23.85	2.74	27.40	25.51	2.82	29.18	27.17	2.91	30.00	27.93	3.00	32.75	30.49	3.12	34.53	32.16	3.21
100	23.20	21.83	2.70	24.99	23.51	2.78	26.77	25.19	2.87	28.56	26.87	2.96	29.61	27.86	3.05	32.13	30.23	3.17	33.91	31.91	3.27
105	22.58	21.47	2.74	24.37	23.17	2.83	26.15	24.87	2.92	27.93	26.56	3.01	29.22	27.79	3.10	31.50	29.96	3.22	33.29	31.66	3.32
110	21.96	21.27	2.78	23.74	23.00	2.86	25.53	24.73	2.95	27.31	26.46	3.04	28.60	27.71	3.14	30.88	29.92	3.26	32.66	31.65	3.36
115	21.33	20.88	2.80	23.12	22.62	2.89	24.90	24.37	2.98	26.69	26.11	3.07	27.98	27.37	3.17	30.26	29.61	3.29	32.04	31.35	3.39
118	20.70	20.40	2.83	22.50	22.18	2.92	24.00	23.66	3.01	25.80	25.43	3.10	27.00	26.61	3.20	29.25	28.83	3.32	30.90	30.46	3.42
122	19.72	19.48	2.84	21.41	21.15	2.93	23.10	22.82	3.02	24.78	24.49	3.11	26.00	25.69	3.21	28.16	27.83	3.34	29.85	29.50	3.44

Table 22: LSN360HV3/LSU360HV3 Cooling Capacities

Outdoor Air Temp. (°F DB)	Indoor Air Temperature (°F DB/ °F WB)																				
	64 / 53			68 / 57			72 / 61			77 / 64			80 / 67			86 / 72			90 / 75		
	TC	SHC	PI	TC	SHC	PI	TC	SHC	PI	TC	SHC	PI	TC	SHC	PI	TC	SHC	PI	TC	SHC	PI
14	20.20	17.72	1.71	21.71	19.04	1.77	23.23	20.37	1.82	24.74	21.70	1.88	25.43	22.30	1.94	27.77	24.35	2.01	29.28	25.68	2.07
23	21.69	18.35	1.71	23.31	19.72	1.76	24.94	21.10	1.81	26.56	22.47	1.87	27.31	23.10	1.93	29.81	25.22	2.01	31.43	26.59	2.07
59	26.02	19.71	1.97	27.97	21.18	2.03	29.92	22.66	2.09	31.87	24.13	2.16	32.76	24.81	2.22	35.77	27.09	2.31	37.72	28.56	2.38
70	29.70	24.18	2.90	31.68	25.80	2.99	33.66	27.41	3.08	34.98	28.48	3.18	35.97	29.29	3.27	38.61	31.44	3.41	41.25	33.59	3.51
75	29.32	24.28	2.98	31.31	25.93	3.07	33.29	27.57	3.17	34.65	28.70	3.27	35.64	29.52	3.37	38.12	31.57	3.50	40.92	33.89	3.61
80	28.55	24.05	3.11	30.53	25.72	3.21	32.52	27.39	3.31	33.99	28.63	3.41	35.31	29.75	3.51	37.62	31.69	3.66	40.26	33.92	3.77
85	27.79	24.15	3.33	29.77	25.87	3.43	31.75	27.59	3.54	33.33	28.97	3.64	34.65	30.11	3.76	37.13	32.26	3.91	39.66	34.46	4.02
90	27.03	24.31	3.47	29.00	26.09	3.58	30.98	27.86	3.69	32.67	29.39	3.80	33.99	30.57	3.92	36.63	32.95	4.08	38.87	34.96	4.20
95	26.21	24.41	3.58	28.17	26.23	3.69	30.14	28.06	3.80	32.10	29.89	3.92	33.00	30.73	4.04	36.03	33.54	4.20	37.99	35.37	4.33
100	25.53	24.02	3.64	27.49	25.86	3.75	29.45	27.71	3.86	31.41	29.56	3.98	32.57	30.65	4.11	35.34	33.25	4.27	37.30	35.10	4.40
105	24.84	23.62	3.70	26.80	25.49	3.81	28.76	27.35	3.93	30.73	29.22	4.05	32.14	30.57	4.18	34.65	32.95	4.34	36.62	34.82	4.47
110	24.15	23.40	3.74	26.12	25.30	3.85	28.08	27.21	3.97	30.04	29.11	4.10	31.46	30.48	4.22	33.97	32.91	4.39	35.93	34.81	4.52
115	23.47	22.96	3.77	25.43	24.88	3.89	27.39	26.80	4.01	29.36	28.72	4.13	30.77	30.11	4.26	33.28	32.57	4.43	35.24	34.49	4.57
118	22.77	22.44	3.81	24.75	24.39	3.93	26.40	26.02	4.05	28.38	27.97	4.17	29.70	29.27	4.30	32.18	31.71	4.47	33.99	33.50	4.61
122	21.69	21.43	3.83	23.55	23.27	3.95	25.40	25.10	4.07	27.26	26.94	4.19	28.60	28.26	4.32	30.98	30.61	4.50	32.84	32.45	4.63

DB: Dry Bulb Temperature (°F) WB: Wet Bulb Temperature (°F) TC: Total Capacity (kBtu/h)
 SHC: Sensible Capacity (kBtu/h) PI: Power Input (kW) (includes compressor, indoor fan motor and outdoor fan motor)
 1. All capacities are net, evaporator fan motor heat is deducted.
 2. Grey shading indicates reference data. When operating the unit at this temperature, these values can be different by discontinuous operation.

3. Direct interpolation is permissible. Do not extrapolate.
 Nominal capacity as rated: 0 ft. above sea level with 25 ft. of refrigerant piping.
 0 ft. level difference between outdoor and indoor units.
 Nominal cooling capacity rating obtained with air entering the indoor unit at 80°F dry bulb (DB) and 67°F wet bulb (WB), and outdoor ambient conditions of 95°F dry bulb (DB) and 75°F wet bulb (WB).

Product Data



PERFORMANCE DATA

Cooling Capacity

LSN/LSU240HLV, LSN/LSU300HLV, LSN/LSU360HLV

Table 23: LSN240HLV/LSU240HLV Cooling Capacities

Outdoor Air Temp. (°F DB)	Indoor Air Temperature (°F DB/ °F WB)																				
	64 / 53			68 / 57			72 / 61			77 / 64			80 / 67			86 / 72			90 / 75		
	TC	SHC	PI	TC	SHC	PI	TC	SHC	PI	TC	SHC	PI	TC	SHC	PI	TC	SHC	PI	TC	SHC	PI
14	12.81	9.92	0.75	14.04	10.87	0.77	14.83	11.48	0.79	15.83	12.26	0.82	16.74	12.96	0.84	17.41	13.48	0.88	18.86	14.60	0.90
17	12.92	10.00	0.75	14.39	11.14	0.77	15.21	11.77	0.79	16.24	12.57	0.82	17.37	13.45	0.84	18.08	14.00	0.88	19.34	14.97	0.90
23	14.31	11.08	0.74	15.38	11.91	0.77	16.45	12.74	0.79	17.52	13.57	0.81	18.85	14.59	0.84	19.66	15.22	0.87	20.73	16.05	0.90
59	17.35	13.43	0.86	18.65	14.44	0.88	19.95	15.45	0.91	21.25	16.45	0.94	21.84	16.91	0.97	23.85	18.46	1.01	25.14	19.47	1.04
70	19.80	15.33	1.26	21.12	16.35	1.30	22.44	17.38	1.34	23.32	18.06	1.38	23.98	18.57	1.43	25.74	19.93	1.48	27.50	21.29	1.53
75	19.55	15.13	1.30	20.87	16.16	1.34	22.20	17.19	1.38	23.10	17.89	1.42	23.76	18.40	1.47	25.41	19.67	1.53	27.28	21.12	1.57
80	19.03	14.74	1.36	20.36	15.76	1.40	21.68	16.79	1.44	22.66	17.55	1.49	23.54	18.23	1.53	25.08	19.42	1.59	26.84	20.78	1.64
85	18.53	14.35	1.45	19.85	15.37	1.49	21.16	16.39	1.54	22.22	17.20	1.59	23.10	17.89	1.64	24.75	19.16	1.70	26.44	20.47	1.75
90	18.02	13.95	1.51	19.34	14.97	1.56	20.65	15.99	1.61	21.78	16.86	1.66	22.66	17.55	1.71	24.42	18.91	1.78	25.91	20.06	1.83
95	17.47	13.53	1.56	18.78	14.54	1.61	20.09	15.56	1.66	21.40	16.57	1.71	22.00	17.03	1.76	24.02	18.60	1.83	25.33	19.61	1.89
100	17.02	13.18	1.58	18.33	14.19	1.63	19.63	15.20	1.68	20.94	16.22	1.74	21.71	16.81	1.79	23.56	18.24	1.86	24.87	19.26	1.92
105	16.56	12.82	1.61	17.87	13.84	1.66	19.18	14.85	1.71	20.48	15.86	1.76	21.43	16.59	1.82	23.10	17.89	1.89	24.41	18.90	1.95
110	16.10	12.47	1.63	17.41	13.48	1.68	18.72	14.49	1.73	20.03	15.51	1.78	20.97	16.24	1.84	22.64	17.53	1.91	23.95	18.55	1.97
115	15.64	12.11	1.64	16.95	13.13	1.69	18.26	14.14	1.75	19.57	15.15	1.80	20.52	15.88	1.86	22.19	17.18	1.93	23.50	18.19	1.99
118	15.18	11.75	1.66	16.50	12.78	1.71	17.60	13.63	1.76	18.92	14.65	1.82	19.80	15.33	1.87	21.45	16.61	1.95	22.66	17.55	2.01

Table 24: LSN300HLV/LSU300HLV Cooling Capacities

Outdoor Air Temp. (°F DB)	Indoor Air Temperature (°F DB/ °F WB)																				
	64 / 53			68 / 57			72 / 61			77 / 64			80 / 67			86 / 72			90 / 75		
	TC	SHC	PI	TC	SHC	PI	TC	SHC	PI	TC	SHC	PI	TC	SHC	PI	TC	SHC	PI	TC	SHC	PI
14	17.47	13.52	1.27	19.14	14.82	1.31	20.22	15.65	1.35	21.59	16.72	1.39	22.82	17.67	1.44	23.74	18.38	1.50	25.72	19.91	1.54
17	17.62	13.64	1.27	19.63	15.20	1.31	20.73	16.05	1.35	22.14	17.15	1.40	23.69	18.34	1.44	24.66	19.10	1.50	26.37	20.42	1.54
23	19.51	15.10	1.27	20.97	16.24	1.31	22.43	17.37	1.35	23.89	18.50	1.39	25.70	19.90	1.43	26.81	20.76	1.49	28.27	21.89	1.53
59	23.66	18.32	1.46	25.43	19.69	1.51	27.20	21.06	1.55	28.97	22.43	1.60	29.79	23.06	1.65	32.52	25.18	1.72	34.29	26.55	1.77
70	27.00	20.91	2.15	28.80	22.30	2.22	30.60	23.69	2.29	31.80	24.62	2.36	32.70	25.32	2.43	35.10	27.18	2.53	37.50	29.04	2.60
75	26.65	20.64	2.21	28.46	22.04	2.28	30.27	23.44	2.35	31.50	24.39	2.43	32.40	25.09	2.50	34.65	26.83	2.60	37.20	28.80	2.68
80	25.96	20.10	2.31	27.76	21.49	2.38	29.56	22.89	2.46	30.90	23.93	2.53	32.40	24.86	2.61	34.20	26.48	2.71	36.60	28.34	2.80
85	25.27	19.56	2.47	27.06	20.95	2.55	28.86	22.35	2.63	30.30	23.46	2.71	31.50	24.39	2.79	33.75	26.13	2.90	36.05	27.91	2.99
90	24.57	19.03	2.58	26.37	20.42	2.66	28.16	21.80	2.74	29.70	23.00	2.82	30.90	23.93	2.91	33.30	25.78	3.03	35.33	27.36	3.12
95	23.83	18.45	2.66	25.61	19.83	2.74	27.40	21.21	2.82	29.18	22.60	2.91	30.00	23.23	3.00	32.75	25.36	3.12	34.53	26.74	3.21
100	23.20	17.97	2.70	24.99	19.35	2.78	26.77	20.73	2.87	28.56	22.11	2.96	29.61	22.93	3.05	32.13	24.88	3.17	33.91	26.26	3.27
105	22.58	17.48	2.74	24.37	18.87	2.83	26.15	20.25	2.92	27.93	21.63	3.01	29.22	22.63	3.10	31.50	24.39	3.22	33.29	25.77	3.32
110	21.96	17.00	2.78	23.74	18.38	2.86	25.53	19.76	2.95	27.31	21.15	3.04	28.60	22.14	3.14	30.88	23.91	3.26	32.66	25.29	3.36
115	21.33	16.52	2.80	23.12	17.90	2.89	24.90	19.28	2.98	26.69	20.66	3.07	27.98	21.66	3.17	30.26	23.43	3.29	32.04	24.81	3.39
118	20.70	16.03	2.83	22.50	17.42	2.92	24.00	18.58	3.01	25.80	19.98	3.10	27.00	20.91	3.20	29.25	22.65	3.32	30.90	23.93	3.42

Table 25: LSN360HLV/LSU360HLV Cooling Capacities

Outdoor Air Temp. (°F DB)	Indoor Air Temperature (°F DB/ °F WB)																				
	64 / 53			68 / 57			72 / 61			77 / 64			80 / 67			86 / 72			90 / 75		
	TC	SHC	PI	TC	SHC	PI	TC	SHC	PI	TC	SHC	PI	TC	SHC	PI	TC	SHC	PI	TC	SHC	PI
14	19.21	14.88	1.71	21.05	16.30	1.77	22.24	17.22	1.82	23.75	18.39	1.88	25.10	19.44	1.94	26.12	20.22	2.01	28.29	21.90	2.07
17	19.38	15.00	1.72	21.59	16.72	1.77	22.81	17.66	1.82	24.36	18.86	1.88	26.06	20.17	1.94	27.13	21.00	2.02	29.01	22.46	2.08
23	21.46	16.62	1.71	23.07	17.86	1.76	24.67	19.10	1.81	26.28	20.35	1.87	28.27	21.89	1.93	29.49	22.84	2.01	31.10	24.08	2.07
59	26.02	20.15	1.97	27.97	21.66	2.03	29.92	23.17	2.09	31.87	24.68	2.16	32.76	25.37	2.22	35.77	27.70	2.31	37.72	29.20	2.38
70	29.70	23.00	2.90	31.68	24.53	2.99	33.66	26.06	3.08	34.98	27.09	3.18	35.97	27.85	3.27	38.61	29.90	3.41	41.25	31.94	3.51
75	29.32	22.70	2.98	31.31	24.24	3.07	33.29	25.78	3.17	34.65	26.83	3.27	35.64	27.60	3.37	38.12	29.51	3.50	40.92	31.68	3.61
80	28.55	22.11	3.11	30.53	23.64	3.21	32.52	25.18	3.31	33.99	26.32	3.41	35.31	27.34	3.51	37.62	29.13	3.66	40.26	31.17	3.77
85	27.79	21.52	3.33	29.77	23.05	3.43	31.75	24.58	3.54	33.33	25.81	3.64	34.65	26.83	3.76	37.13	28.75	3.91	39.66	30.71	4.02
90	27.03	20.93	3.47	29.00	22.46	3.58	30.98	23.99	3.69	32.67	25.30	3.80	33.99	26.32	3.92	36.63	28.36	4.08	38.87	30.09	4.20
95	26.21	20.30	3.58	28.17	21.82	3.69	30.14	23.33	3.80	32.10	24.85	3.92	33.00	25.55	4.04	36.03	27.89	4.20	37.99	29.41	4.33
100	25.53	19.76	3.64	27.49	21.28	3.75	29.45	22.80	3.86	31.41	24.32	3.98	32.57	25.22	4.11	35.34	27.36	4.27	37.30	28.88	4.40
105	24.84	19.23	3.70	26.80	20.75	3.81	28.76	22.27	3.93	30.73	23.79	4.05	32.14	24.89	4.18	34.65	26.83	4.34	36.62	28.35	4.47
110	24.15	18.70	3.74	26.12	20.22	3.85	28.08	21.74	3.97	30.04	23.26	4.10	31.46	24.36	4.22	33.97	26.30	4.39	35.93	27.82	4.52
115	23.47	18.17	3.77	25.43	19.69	3.89	27.39	21.21	4.01	29.36	22.73	4.13	30.77	23.83	4.26	33.28	25.77	4.43	35.24	27.29	4.57
118	22.77	17.63	3.81	24.75	19.16	3.93	26.40	20.44	4.05	28.38	21.97	4.17	29.70	23.00	4.30	32.18	24.91	4.47	33.99	26.32	4.61

DB: Dry Bulb Temperature (°F) WB: Wet Bulb Temperature (°F) TC: Total Capacity (kBtu/h)
 SHC: Sensible Capacity (kBtu/h) PI: Power Input (kW) (includes compressor, indoor fan motor and outdoor fan motor)

1. All capacities are net, evaporator fan motor heat is deducted.
2. Direct interpolation is permissible. Do not extrapolate.

Nominal capacity as rated: 0 ft. above sea level with 25 ft. of refrigerant piping.
 0 ft. level difference between outdoor and indoor units.
 Nominal cooling capacity rating obtained with air entering the indoor unit at 80°F dry bulb (DB) and 67°F wet bulb (WB), and outdoor ambient conditions of 95°F dry bulb (DB) and 75°F wet bulb (WB).



PERFORMANCE DATA

Heating Capacity LSN/LSU091HSV3, LSN/LSU121HSV3

Table 26: LSN091HSV3/LSU091HSV3 Heating Capacities

Outdoor Air Temp.		Indoor Air Temperature (°F DB/ °F WB)													
°F DB	°F WB	60		64		68		70		72		75		86	
		TC	PI	TC	PI	TC	PI	TC	PI	TC	PI	TC	PI	TC	PI
-3	-4	5.49	0.50	5.32	0.50	5.27	0.50	5.21	0.49	5.17	0.49	5.07	0.49	4.95	0.49
0	-1	5.97	0.55	5.79	0.55	5.73	0.55	5.68	0.54	5.63	0.54	5.52	0.54	5.39	0.54
6	5	6.32	0.58	6.13	0.57	6.07	0.57	6.01	0.57	5.96	0.57	5.84	0.56	5.70	0.56
10	9	6.60	0.60	6.40	0.59	6.33	0.59	6.27	0.59	6.22	0.59	6.10	0.58	5.95	0.58
16	14	6.81	0.60	6.60	0.60	6.53	0.60	6.47	0.59	6.42	0.59	6.29	0.59	6.14	0.59
19	17	6.94	0.62	6.73	0.62	6.67	0.62	6.60	0.61	6.55	0.61	6.42	0.60	6.27	0.60
24	23	7.62	0.64	7.39	0.63	7.32	0.63	7.25	0.62	7.19	0.62	7.05	0.62	6.88	0.62
32	30	9.15	0.67	8.88	0.66	8.79	0.66	8.70	0.66	8.63	0.66	8.46	0.65	8.26	0.65
41	38	10.51	0.70	10.20	0.69	10.09	0.69	9.99	0.68	9.92	0.68	9.72	0.68	9.49	0.68
43	40	10.85	0.70	10.53	0.70	10.42	0.70	10.32	0.69	10.24	0.69	10.03	0.68	9.79	0.68
47	43	11.36	0.71	11.02	0.71	10.91	0.71	10.80	0.70	10.72	0.70	10.50	0.69	10.25	0.69
53	50	11.48	0.72	11.13	0.71	11.02	0.71	10.91	0.71	10.82	0.71	10.61	0.70	10.36	0.70
59	55	11.74	0.73	11.38	0.72	11.27	0.72	11.16	0.71	11.07	0.71	10.85	0.71	10.59	0.71
64	60	11.99	0.74	11.63	0.74	11.51	0.74	11.39	0.73	11.31	0.73	11.08	0.72	10.82	0.72
70	66	12.22	0.75	11.85	0.75	11.73	0.75	11.61	0.74	11.52	0.74	11.29	0.73	11.02	0.73
75	71	12.39	0.76	12.01	0.76	11.89	0.76	11.77	0.75	11.68	0.75	11.45	0.74	11.18	0.74
78	75	12.50	0.77	12.12	0.76	12.00	0.76	11.88	0.76	11.79	0.76	11.55	0.75	11.28	0.75

Table 27: LSN121HSV3/LSU121HSV3 Heating Capacities

Outdoor Air Temp.		Indoor Air Temperature (°F DB/ °F WB)													
°F DB	°F WB	60		64		68		70		72		75		86	
		TC	PI	TC	PI	TC	PI	TC	PI	TC	PI	TC	PI	TC	PI
-3	-4	7.23	0.70	7.01	0.70	6.94	0.70	6.87	0.69	6.82	0.69	6.68	0.68	6.52	0.68
0	-1	7.87	0.77	7.63	0.76	7.56	0.76	7.48	0.76	7.42	0.76	7.28	0.75	7.10	0.75
6	5	8.33	0.81	8.08	0.80	8.00	0.80	7.92	0.79	7.86	0.79	7.70	0.78	7.52	0.78
10	9	8.70	0.83	8.43	0.82	8.35	0.82	8.27	0.82	8.20	0.82	8.04	0.81	7.85	0.81
16	14	8.97	0.84	8.70	0.83	8.61	0.83	8.53	0.82	8.46	0.82	8.29	0.82	8.09	0.82
19	17	9.15	0.87	8.88	0.86	8.79	0.86	8.70	0.85	8.63	0.85	8.46	0.84	8.26	0.84
24	23	9.90	0.89	9.60	0.88	9.50	0.88	9.41	0.87	9.34	0.87	9.15	0.86	8.93	0.86
32	30	11.57	0.94	11.22	0.93	11.11	0.93	11.00	0.93	10.92	0.93	10.70	0.92	10.44	0.92
41	38	13.06	0.99	12.67	0.98	12.54	0.98	12.42	0.97	12.32	0.97	12.07	0.96	11.79	0.96
43	40	13.44	1.00	13.03	0.99	12.90	0.99	12.77	0.98	12.67	0.98	12.42	0.97	12.12	0.97
47	43	14.00	1.02	13.57	1.01	13.43	1.01	13.30	1.00	13.20	1.00	12.93	0.99	12.63	0.99
53	50	14.14	1.03	13.71	1.02	13.57	1.02	13.43	1.01	13.33	1.01	13.06	1.00	12.75	1.00
59	55	14.46	1.04	14.02	1.03	13.88	1.03	13.74	1.02	13.63	1.02	13.36	1.01	13.04	1.01
64	60	14.76	1.06	14.32	1.05	14.17	1.05	14.03	1.04	13.92	1.04	13.64	1.03	13.32	1.03
70	66	15.04	1.08	14.59	1.07	14.44	1.07	14.30	1.06	14.19	1.06	13.90	1.04	13.57	1.04
75	71	15.25	1.09	14.79	1.08	14.64	1.08	14.50	1.07	14.39	1.07	14.10	1.06	13.76	1.06
78	75	15.39	1.10	14.93	1.09	14.78	1.09	14.63	1.08	14.52	1.08	14.23	1.07	13.89	1.07

DB: Dry Bulb Temperature (°F) WB: Wet Bulb Temperature (°F) TC: Total Capacity (kBtu/h)
 PI: Power Input (kW) (includes compressor, indoor fan motor and outdoor fan motor)
 1. All capacities are net, evaporator fan motor heat is deducted.
 2. Direct interpolation is permissible. Do not extrapolate.

Nominal capacity as rated: 0 ft. above sea level with 25 ft. of refrigerant piping.
 0 ft. level difference between outdoor and indoor units.
 Nominal cooling capacity rating obtained with air entering the indoor unit at 80°F dry bulb (DB) and 67°F wet bulb (WB), and outdoor ambient conditions of 95°F dry bulb (DB) and 75°F wet bulb (WB).

PERFORMANCE DATA

Heating Capacity

LSN/LSU181HSV3, LSN/LSU240HSV3

Table 28: LSN181HSV3/LSU181HSV3 Heating Capacities

Outdoor Air Temp.		Indoor Air Temperature (°F DB/ °F WB)													
°F DB	°F WB	60		64		68		70		72		75		86	
		TC	PI	TC	PI	TC	PI	TC	PI	TC	PI	TC	PI	TC	PI
-3	-4	11.22	1.17	10.88	1.16	10.77	1.16	10.67	1.15	10.58	1.15	10.37	1.14	10.12	1.14
0	-1	12.22	1.29	11.85	1.28	11.73	1.28	11.61	1.26	11.52	1.26	11.29	1.25	11.02	1.25
6	5	12.93	1.35	12.53	1.33	12.41	1.33	12.29	1.32	12.19	1.32	11.95	1.31	11.66	1.31
10	9	13.50	1.39	13.09	1.38	12.95	1.38	12.83	1.36	12.73	1.36	12.47	1.35	12.17	1.35
16	14	13.92	1.40	13.50	1.39	13.36	1.39	13.23	1.38	13.13	1.38	12.87	1.36	12.56	1.36
19	17	14.21	1.45	13.77	1.43	13.64	1.43	13.50	1.42	13.40	1.42	13.13	1.41	12.82	1.41
24	23	15.58	1.50	15.11	1.49	14.96	1.49	14.81	1.47	14.69	1.47	14.40	1.46	14.06	1.46
32	30	18.68	1.62	18.11	1.61	17.93	1.61	17.75	1.59	17.61	1.59	17.26	1.57	16.85	1.57
41	38	21.43	1.73	20.78	1.71	20.57	1.71	20.37	1.69	20.21	1.69	19.80	1.68	19.33	1.68
43	40	22.12	1.76	21.45	1.74	21.23	1.74	21.02	1.72	20.86	1.72	20.44	1.70	19.95	1.70
47	43	23.15	1.80	22.45	1.78	22.22	1.78	22.00	1.76	21.83	1.76	21.39	1.74	20.88	1.74
53	50	23.38	1.81	22.67	1.80	22.44	1.80	22.22	1.78	22.05	1.78	21.61	1.76	21.09	1.76
59	55	23.91	1.83	23.19	1.81	22.95	1.81	22.73	1.80	22.55	1.80	22.10	1.78	21.57	1.78
64	60	24.42	1.87	23.68	1.85	23.44	1.85	23.21	1.83	23.03	1.83	22.57	1.81	22.03	1.81
70	66	24.89	1.89	24.13	1.88	23.89	1.88	23.65	1.86	23.47	1.86	23.00	1.84	22.45	1.84
75	71	25.23	1.92	24.47	1.90	24.22	1.90	23.98	1.88	23.80	1.88	23.32	1.86	22.76	1.86
78	75	25.46	1.94	24.69	1.92	24.44	1.92	24.20	1.90	24.02	1.90	23.53	1.88	22.97	1.88

Table 29: LSN240HSV3/LSU240HSV3 Heating Capacities

Outdoor Air Temp.		Indoor Air Temperature (°F DB/ °F WB)													
°F DB	°F WB	60		64		68		70		72		75		86	
		TC	PI	TC	PI	TC	PI	TC	PI	TC	PI	TC	PI	TC	PI
-3	-4	15.55	1.63	15.07	1.61	14.92	1.61	14.77	1.60	14.66	1.60	14.37	1.58	14.02	1.58
0	-1	16.92	1.79	16.41	1.77	16.24	1.77	16.08	1.75	15.96	1.75	15.64	1.74	15.27	1.74
6	5	17.91	1.87	17.36	1.85	17.19	1.85	17.02	1.83	16.89	1.83	16.55	1.81	16.15	1.81
10	9	18.69	1.93	18.13	1.91	17.94	1.91	17.77	1.89	17.63	1.89	17.28	1.87	16.86	1.87
16	14	19.28	1.95	18.70	1.93	18.51	1.93	18.33	1.91	18.19	1.91	17.82	1.89	17.40	1.89
19	17	19.68	2.01	19.08	1.99	18.89	1.99	18.70	1.97	18.56	1.97	18.18	1.95	17.75	1.95
24	23	21.12	2.07	20.48	2.05	20.27	2.05	20.07	2.03	19.92	2.03	19.52	2.01	19.05	2.01
32	30	24.36	2.22	23.62	2.20	23.38	2.20	23.15	2.18	22.97	2.18	22.51	2.15	21.98	2.15
41	38	27.24	2.35	26.41	2.32	26.15	2.32	25.89	2.30	25.69	2.30	25.17	2.28	24.58	2.28
43	40	27.96	2.38	27.11	2.36	26.84	2.36	26.57	2.33	26.37	2.33	25.84	2.31	25.23	2.31
47	43	29.04	2.43	28.16	2.40	27.88	2.40	27.60	2.38	27.39	2.38	26.84	2.36	26.20	2.36
53	50	29.33	2.45	28.44	2.43	28.15	2.43	27.88	2.40	27.66	2.40	27.11	2.38	26.46	2.38
59	55	30.00	2.48	29.09	2.45	28.80	2.45	28.51	2.43	28.29	2.43	27.72	2.40	27.07	2.40
64	60	30.64	2.52	29.71	2.50	29.41	2.50	29.12	2.48	28.90	2.48	28.32	2.45	27.64	2.45
70	66	31.22	2.56	30.27	2.54	29.97	2.54	29.67	2.51	29.44	2.51	28.85	2.49	28.17	2.49
75	71	31.66	2.60	30.70	2.57	30.38	2.57	30.08	2.55	29.85	2.55	29.25	2.52	28.56	2.52
78	75	31.95	2.62	30.98	2.60	30.66	2.60	30.36	2.57	30.13	2.57	29.52	2.54	28.82	2.54

DB: Dry Bulb Temperature (°F) WB: Wet Bulb Temperature (°F) TC: Total Capacity (kBtu/h)
 PI: Power Input (kW) (includes compressor, indoor fan motor and outdoor fan motor)

1. All capacities are net, evaporator fan motor heat is deducted.
2. Direct interpolation is permissible. Do not extrapolate.

Nominal capacity as rated: 0 ft. above sea level with 25 ft. of refrigerant piping.
 0 ft. level difference between outdoor and indoor units.

Nominal cooling capacity rating obtained with air entering the indoor unit at 80°F dry bulb (DB) and 67°F wet bulb (WB), and outdoor ambient conditions of 95°F dry bulb (DB) and 75°F wet bulb (WB).

PERFORMANCE DATA

Heating Capacity LSN/LSU307HV3, LSN/LSU360HV3

Table 30: LSN307HV3/LSU307HV3 Heating Capacities

Outdoor Air Temp.		Indoor Air Temperature (°F DB/ °F WB)													
°F DB	°F WB	60		64		68		70		72		75		86	
		TC	PI	TC	PI	TC	PI	TC	PI	TC	PI	TC	PI	TC	PI
-3	-4	18.62	2.04	18.06	2.02	17.87	2.02	17.70	2.00	17.56	2.00	17.21	1.98	16.80	1.98
0	-1	20.27	2.24	19.66	2.22	19.46	2.22	19.26	2.20	19.12	2.20	18.73	2.18	18.29	2.18
6	5	21.45	2.34	20.80	2.32	20.59	2.32	20.38	2.30	20.23	2.30	19.82	2.27	19.35	2.27
10	9	22.39	2.42	21.71	2.39	21.49	2.39	21.28	2.37	21.12	2.37	20.69	2.35	20.20	2.35
16	14	23.10	2.44	22.40	2.42	22.17	2.42	21.95	2.40	21.78	2.40	21.35	2.37	20.84	2.37
19	17	23.57	2.52	22.86	2.49	22.62	2.49	22.40	2.47	22.23	2.47	21.78	2.45	21.26	2.45
24	23	25.12	2.62	24.36	2.59	24.12	2.59	23.88	2.57	23.69	2.57	23.22	2.54	22.67	2.54
32	30	28.62	2.84	27.75	2.81	27.47	2.81	27.20	2.79	26.99	2.79	26.45	2.76	25.82	2.76
41	38	31.73	3.04	30.77	3.01	30.46	3.01	30.15	2.98	29.92	2.98	29.32	2.95	28.63	2.95
43	40	32.51	3.09	31.52	3.06	31.20	3.06	30.89	3.03	30.66	3.03	30.04	3.00	29.33	3.00
47	43	33.67	3.16	32.65	3.13	32.32	3.13	32.00	3.10	31.76	3.10	31.12	3.07	30.38	3.07
53	50	34.01	3.19	32.98	3.16	32.64	3.16	32.32	3.13	32.07	3.13	31.43	3.10	30.68	3.10
59	55	34.78	3.23	33.73	3.19	33.39	3.19	33.06	3.16	32.80	3.16	32.14	3.13	31.38	3.13
64	60	35.52	3.29	34.45	3.26	34.10	3.26	33.76	3.22	33.50	3.22	32.83	3.19	32.05	3.19
70	66	36.20	3.34	35.10	3.30	34.74	3.30	34.40	3.27	34.14	3.27	33.45	3.24	32.66	3.24
75	71	36.70	3.38	35.59	3.35	35.23	3.35	34.88	3.32	34.61	3.32	33.92	3.28	33.11	3.28
78	75	37.04	3.41	35.92	3.38	35.55	3.38	35.20	3.35	34.93	3.35	34.23	3.31	33.42	3.31

Table 31: LSN360HV3/LSU360HV3 Heating Capacities

Outdoor Air Temp.		Indoor Air Temperature (°F DB/ °F WB)													
°F DB	°F WB	60		64		68		70		72		75		86	
		TC	PI	TC	PI	TC	PI	TC	PI	TC	PI	TC	PI	TC	PI
-3	-4	20.28	2.35	19.67	2.32	19.47	2.32	19.28	2.30	19.13	2.30	18.74	2.28	18.30	2.28
0	-1	22.08	2.58	21.41	2.55	21.19	2.55	20.98	2.53	20.82	2.53	20.41	2.50	19.92	2.50
6	5	23.36	2.69	22.66	2.67	22.43	2.67	22.20	2.64	22.03	2.64	21.59	2.61	21.08	2.61
10	9	24.39	2.78	23.65	2.75	23.41	2.75	23.18	2.73	23.00	2.73	22.54	2.70	22.01	2.70
16	14	25.16	2.81	24.40	2.78	24.15	2.78	23.91	2.75	23.73	2.75	23.25	2.73	22.70	2.73
19	17	25.68	2.90	24.90	2.87	24.64	2.87	24.40	2.84	24.21	2.84	23.73	2.81	23.16	2.81
24	23	27.42	3.05	26.59	3.02	26.32	3.02	26.06	2.99	25.86	2.99	25.34	2.96	24.74	2.96
32	30	31.36	3.41	30.41	3.37	30.10	3.37	29.80	3.34	29.57	3.34	28.98	3.31	28.29	3.31
41	38	34.85	3.72	33.80	3.68	33.45	3.68	33.12	3.65	32.87	3.65	32.21	3.61	31.44	3.61
43	40	35.73	3.80	34.64	3.76	34.29	3.76	33.95	3.72	33.69	3.72	33.02	3.69	32.23	3.69
47	43	37.04	3.92	35.92	3.88	35.55	3.88	35.20	3.84	34.93	3.84	34.23	3.80	33.42	3.80
53	50	37.41	3.96	36.28	3.92	35.91	3.92	35.55	3.88	35.28	3.88	34.57	3.84	33.75	3.84
59	55	38.26	4.00	37.10	3.96	36.73	3.96	36.36	3.92	36.08	3.92	35.36	3.88	34.52	3.88
64	60	39.08	4.07	37.89	4.03	37.51	4.03	37.14	3.99	36.85	3.99	36.11	3.95	35.25	3.95
70	66	39.82	4.13	38.61	4.09	38.22	4.09	37.84	4.05	37.55	4.05	36.80	4.01	35.92	4.01
75	71	40.37	4.19	39.15	4.15	38.75	4.15	38.37	4.11	38.07	4.11	37.31	4.07	36.42	4.07
78	75	40.74	4.23	39.51	4.19	39.11	4.19	38.72	4.15	38.42	4.15	37.65	4.11	36.76	4.11

DB: Dry Bulb Temperature (°F) WB: Wet Bulb Temperature (°F) TC: Total Capacity (kBtu/h)
PI: Power Input (kW) (includes compressor, indoor fan motor and outdoor fan motor)

1. All capacities are net, evaporator fan motor heat is deducted.
2. Direct interpolation is permissible. Do not extrapolate.

Nominal capacity as rated: 0 ft. above sea level with 25 ft. of refrigerant piping.
0 ft. level difference between outdoor and indoor units.

Nominal cooling capacity rating obtained with air entering the indoor unit at 80°F dry bulb (DB) and 67°F wet bulb (WB), and outdoor ambient conditions of 95°F dry bulb (DB) and 75°F wet bulb (WB).

PERFORMANCE DATA

Heating Capacity

LSN/LSU240HLV, LSN/LSU300HLV

Table 32: LSN240HLV/LSU240HLV Heating Capacities

Outdoor Air Temp.		Indoor Air Temperature (°F DB/ °F WB)													
°F DB	°F WB	60		64		68		70		72		75		86	
		TC	PI	TC	PI	TC	PI	TC	PI	TC	PI	TC	PI	TC	PI
-3	-4	16.29	1.59	15.86	1.57	15.72	1.57	15.59	1.56	15.49	1.56	15.22	1.54	14.91	1.54
-0.4	-1	17.53	1.74	17.07	1.73	16.92	1.73	16.77	1.71	16.66	1.71	16.37	1.69	16.04	1.69
6	5	18.43	1.82	17.93	1.80	17.77	1.80	17.62	1.79	17.50	1.79	17.20	1.77	16.84	1.77
10	9	19.14	1.88	18.62	1.86	18.46	1.86	18.30	1.84	18.17	1.84	17.85	1.82	17.48	1.82
16	14	19.67	1.90	19.14	1.88	18.97	1.88	18.81	1.86	18.68	1.86	18.35	1.84	17.96	1.84
19	17	20.03	1.96	19.49	1.94	19.31	1.94	19.06	1.92	19.01	1.92	18.68	1.90	18.29	1.90
24	23	21.74	2.03	21.20	2.01	21.02	2.01	20.77	1.99	20.72	1.99	20.39	1.97	19.99	1.97
32	30	23.73	2.19	23.19	2.17	23.01	2.17	22.76	2.15	22.72	2.15	22.38	2.13	21.99	2.13
41	38	26.01	2.34	25.47	2.31	25.29	2.31	25.04	2.29	24.99	2.29	24.66	2.27	24.26	2.27
43	40	26.58	2.37	26.04	2.35	25.86	2.35	25.61	2.33	25.56	2.33	25.22	2.30	24.83	2.30
47	43	29.04	2.43	28.16	2.40	27.88	2.40	27.00	2.38	27.39	2.38	26.84	2.36	26.20	2.36
53	50	29.33	2.45	28.44	2.43	28.15	2.43	27.88	2.40	27.66	2.40	27.11	2.38	26.46	2.38
59	55	30.00	2.48	29.09	2.45	28.80	2.45	28.51	2.43	28.29	2.43	27.72	2.40	27.07	2.40
64	60	30.64	2.52	29.71	2.50	29.41	2.50	29.12	2.48	28.90	2.48	28.32	2.45	27.64	2.45
70	66	31.22	2.56	30.27	2.54	29.97	2.54	29.67	2.51	29.44	2.51	28.85	2.49	28.17	2.49
75	71	31.66	2.60	30.70	2.57	30.38	2.57	30.08	2.55	29.85	2.55	29.25	2.52	28.56	2.52
78	75	31.95	2.62	30.98	2.60	30.66	2.60	30.36	2.57	30.13	2.57	29.52	2.54	28.82	2.54

Table 33: LSN300HLV/LSU300HLV Heating Capacities

Outdoor Air Temp.		Indoor Air Temperature (°F DB/ °F WB)													
°F DB	°F WB	60		64		68		70		72		75		86	
		TC	PI	TC	PI	TC	PI	TC	PI	TC	PI	TC	PI	TC	PI
-3	-4	18.88	2.07	18.39	2.05	18.23	2.05	18.07	2.03	17.95	2.03	17.65	2.01	17.29	2.01
-0.4	-1	20.33	2.27	19.79	2.25	19.62	2.25	19.45	2.23	19.32	2.23	18.98	2.20	18.59	2.20
6	5	21.36	2.37	20.79	2.35	20.61	2.35	20.43	2.33	20.29	2.33	19.94	2.30	19.52	2.30
10	9	22.19	2.45	21.59	2.43	21.40	2.43	21.21	2.40	21.07	2.40	20.70	2.38	20.27	2.38
16	14	22.81	2.47	22.19	2.45	22.00	2.45	21.80	2.43	21.66	2.43	21.27	2.40	20.83	2.40
19	17	23.22	2.55	22.60	2.53	22.39	2.53	22.10	2.50	22.05	2.50	21.65	2.48	21.20	2.48
24	23	25.20	2.65	24.58	2.62	24.37	2.62	24.08	2.59	24.03	2.59	23.64	2.57	23.18	2.57
32	30	27.51	2.86	26.89	2.83	26.68	2.83	26.39	2.80	26.34	2.80	25.95	2.77	25.49	2.77
41	38	30.15	3.04	29.53	3.01	29.32	3.01	29.03	2.98	28.98	2.98	28.59	2.95	28.13	2.95
43	40	30.81	3.09	30.19	3.06	29.98	3.06	29.69	3.03	29.64	3.03	29.25	3.00	28.79	3.00
47	43	33.67	3.16	32.65	3.13	32.32	3.13	32.00	3.10	31.76	3.10	31.12	3.07	30.38	3.07
53	50	34.01	3.19	32.98	3.16	32.64	3.16	32.32	3.13	32.07	3.13	31.43	3.10	30.68	3.10
59	55	34.78	3.23	33.73	3.19	33.39	3.19	33.06	3.16	32.80	3.16	32.14	3.13	31.38	3.13
64	60	35.52	3.29	34.45	3.26	34.10	3.26	33.76	3.22	33.50	3.22	32.83	3.19	32.05	3.19
70	66	36.20	3.34	35.10	3.30	34.74	3.30	34.40	3.27	34.14	3.27	33.45	3.24	32.66	3.24
75	71	36.70	3.38	35.59	3.35	35.23	3.35	34.88	3.32	34.61	3.32	33.92	3.28	33.11	3.28
78	75	37.04	3.41	35.92	3.38	35.55	3.38	35.20	3.35	34.93	3.35	34.23	3.31	33.42	3.31

DB: Dry Bulb Temperature (°F) WB: Wet Bulb Temperature (°F) TC: Total Capacity (kBtu/h)
 PI: Power Input (kW) (includes compressor, indoor fan motor and outdoor fan motor)

1. All capacities are net, evaporator fan motor heat is deducted.
2. Direct interpolation is permissible. Do not extrapolate.

Nominal capacity as rated: 0 ft. above sea level with 25 ft. of refrigerant piping.
 0 ft. level difference between outdoor and indoor units.

Nominal cooling capacity rating obtained with air entering the indoor unit at 80°F dry bulb (DB) and 67°F wet bulb (WB), and outdoor ambient conditions of 95°F dry bulb (DB) and 75°F wet bulb (WB).



PERFORMANCE DATA

Heating Capacity LSN/LSU360HLV

Table 34: LSN360HLV/LSU360HLV Heating Capacities

Outdoor Air Temp.		Indoor Air Temperature (°F DB/ °F WB)													
°F DB	°F WB	60		64		68		70		72		75		86	
		TC	PI	TC	PI	TC	PI	TC	PI	TC	PI	TC	PI	TC	PI
-3	-4	20.77	2.56	20.23	2.53	20.05	2.53	19.88	2.51	19.75	2.51	19.41	2.48	19.02	2.48
-0.4	-1	22.36	2.81	21.77	2.78	21.58	2.78	21.39	2.76	21.25	2.76	20.88	2.73	20.45	2.73
6	5	23.50	2.94	22.87	2.91	22.67	2.91	22.47	2.88	22.32	2.88	21.93	2.85	21.48	2.85
10	9	24.41	3.03	23.75	3.00	23.54	3.00	23.34	2.97	23.18	2.97	22.77	2.94	22.30	2.94
16	14	25.09	3.07	24.41	3.04	24.20	3.04	23.98	3.01	23.82	3.01	23.40	2.98	22.91	2.98
19	17	25.55	3.16	24.86	3.13	24.63	3.13	24.31	3.10	24.25	3.10	23.82	3.07	23.32	3.07
24	23	27.72	3.28	27.03	3.24	26.81	3.24	26.49	3.21	26.43	3.21	26.00	3.18	25.50	3.18
32	30	30.26	3.54	29.57	3.50	29.35	3.50	29.03	3.47	28.97	3.47	28.54	3.43	28.04	3.43
41	38	33.17	3.77	32.48	3.73	32.26	3.73	31.93	3.70	31.87	3.70	31.44	3.66	30.94	3.66
43	40	33.89	3.83	33.21	3.79	32.98	3.79	32.66	3.75	32.60	3.75	32.17	3.72	31.67	3.72
47	43	37.04	3.92	35.92	3.88	35.55	3.88	35.20	3.84	34.93	3.84	34.23	3.80	33.42	3.80
53	50	37.41	3.96	36.28	3.92	35.91	3.92	35.55	3.88	35.28	3.88	34.57	3.84	33.75	3.84
59	55	38.26	4.00	37.10	3.96	36.73	3.96	36.36	3.92	36.08	3.92	35.36	3.88	34.52	3.88
64	60	39.08	4.07	37.89	4.03	37.51	4.03	37.14	3.99	36.85	3.99	36.11	3.95	35.25	3.95
70	66	39.82	4.13	38.61	4.09	38.22	4.09	37.84	4.05	37.55	4.05	36.80	4.01	35.92	4.01
75	71	40.37	4.19	39.15	4.15	38.75	4.15	38.37	4.11	38.07	4.11	37.31	4.07	36.42	4.07
78	75	40.74	4.23	39.51	4.19	39.11	4.19	38.72	4.15	38.42	4.15	37.65	4.11	36.76	4.11

DB: Dry Bulb Temperature (°F) WB: Wet Bulb Temperature (°F) TC: Total Capacity (kBtu/h)
PI: Power Input (kW) (includes compressor, indoor fan motor and outdoor fan motor)

1. All capacities are net, evaporator fan motor heat is deducted.
2. Direct interpolation is permissible. Do not extrapolate.

Nominal capacity as rated: 0 ft. above sea level with 25 ft. of refrigerant piping.
0 ft. level difference between outdoor and indoor units.

Nominal cooling capacity rating obtained with air entering the indoor unit at 80°F dry bulb (DB) and 67°F wet bulb (WB), and outdoor ambient conditions of 95°F dry bulb (DB) and 75°F wet bulb (WB).





APPLICATION GUIDELINES

“Equipment Selection Procedure” on page 54

“Building Ventilation Design Guide” on page 57

“Placement Considerations” on page 59

AirMacalson
Your Appliance Authority™
800-570-3355

EQUIPMENT SELECTION PROCEDURE

Cooling / Heating Correction Factors

For the Single Zone High Efficiency, Single Zone Standard and Single Zone Extended Pipe systems, calculate the equivalent length of the liquid line from the outdoor unit to the indoor unit. Also, determine the elevation difference of the indoor unit above or below the outdoor unit. Find corresponding cooling or heating capacity correction factors as shown in Figures 17-22. Multiply the correction factors by the cooling or heating capacity obtained from the capacity tables using design conditions. The resultant is the NET cooling or heating capacity.

Figure 17: LS091HSV3, LS121HSV3 Cooling Coefficient Factor

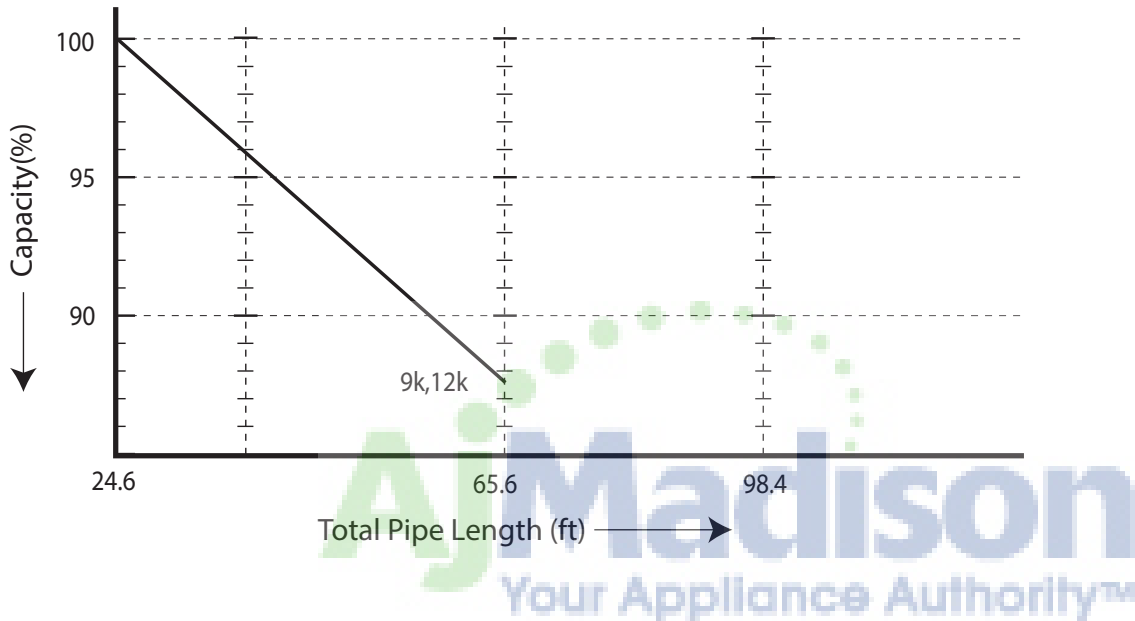
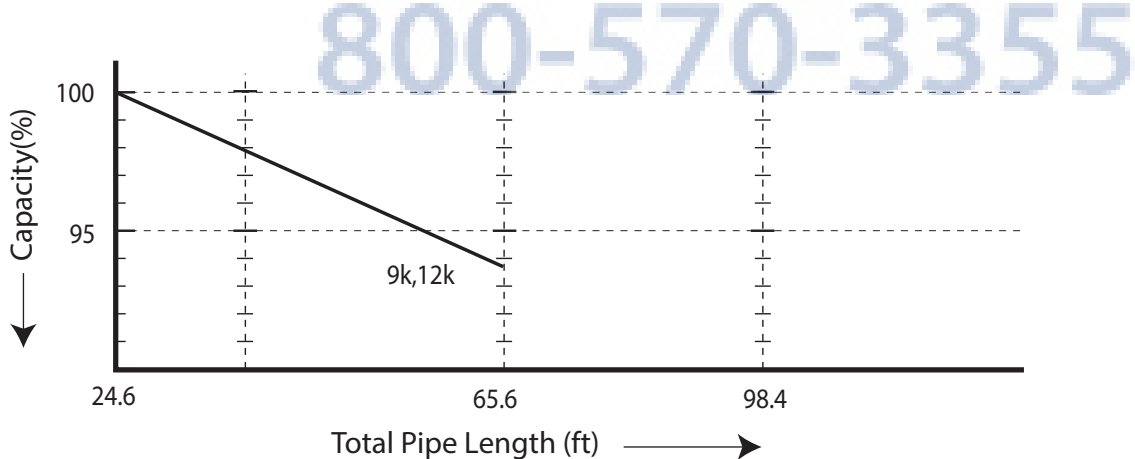

Figure 18: LS091HSV3, LS121HSV3 Heating Coefficient Factor



EQUIPMENT SELECTION PROCEDURE

Figure 19: LS181HSV3, LS240HSV3, LS307HV3, LS360HV3 Cooling Coefficient Factor

Cooling

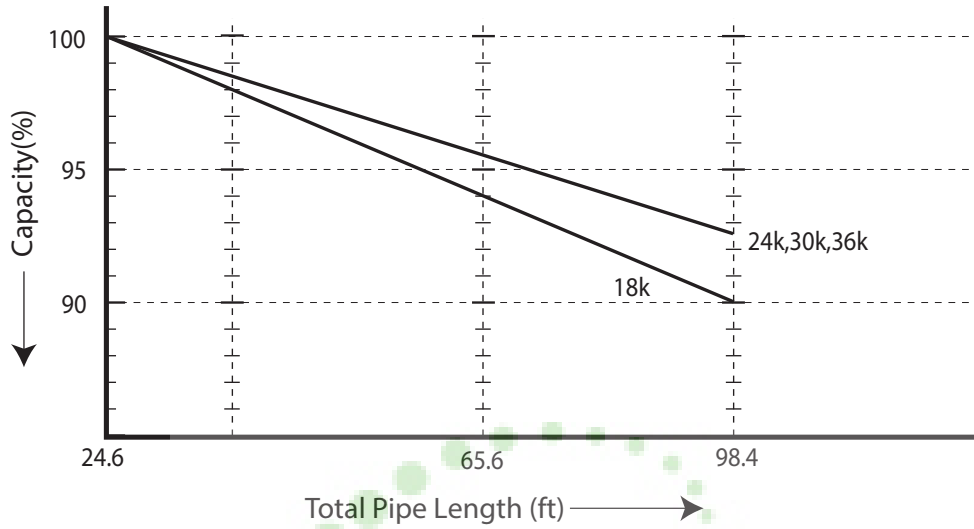
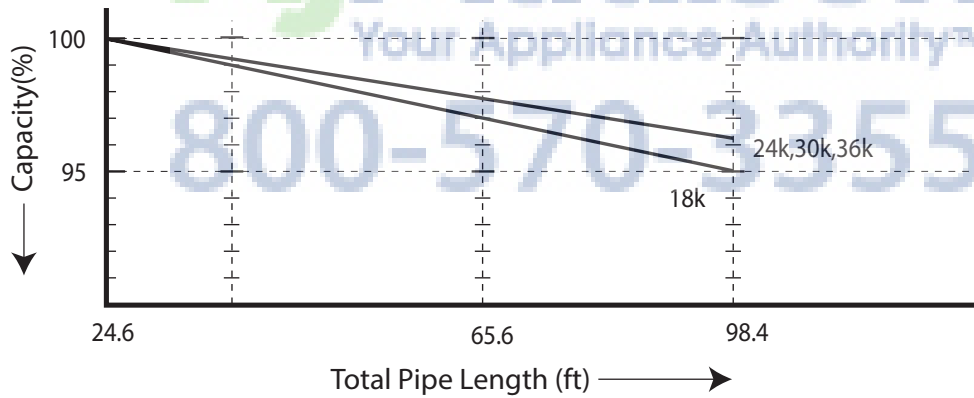

Figure 20: LS181HSV3, LS240HSV3, LS307HV3, LS360HV3 Heating Coefficient Factor

Heating



EQUIPMENT SELECTION PROCEDURE

Figure 21: LS240HLV, LS300HLV, LS360HLV Cooling Coefficient Factor
Cooling

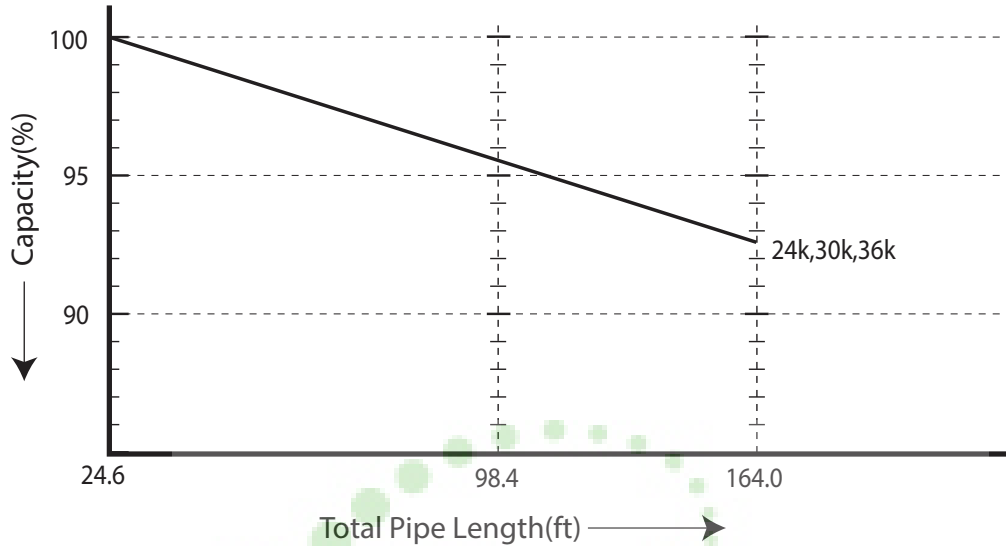
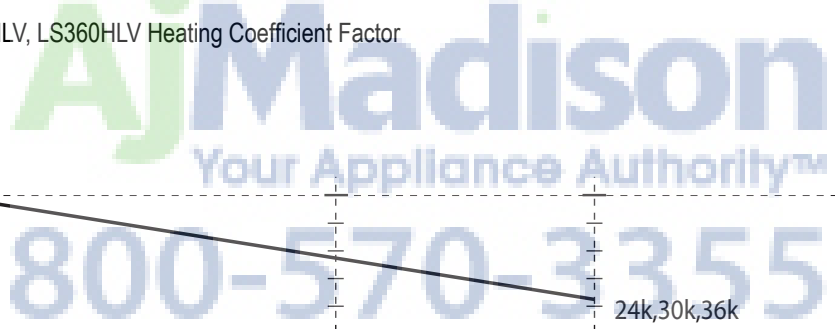
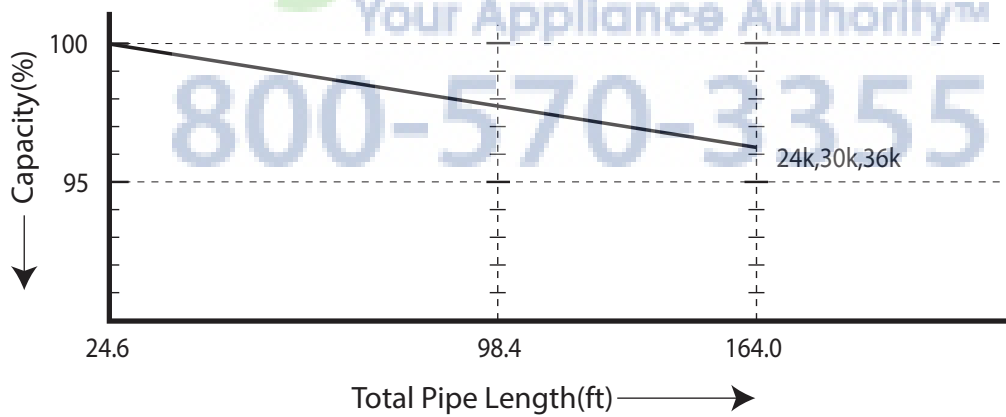

Figure 22: LS240HLV, LS300HLV, LS360HLV Heating Coefficient Factor
Heating



BUILDING VENTILATION DESIGN GUIDE

Building Ventilation Design Guide

ASHRAE 62.1 and local codes specify the minimum volume of outdoor air that must be provided to an occupied space. Outdoor air is required to minimize adverse health effects, and it provides acceptable indoor air quality for building occupants. The three methods of accomplishing this with single zone systems are summarized here.

Note

Although we believe that these building ventilation methods have been portrayed accurately, none of the methods have been tested, verified, or evaluated by LG Electronics, U.S.A., Inc.,. In all cases, the designer, installer, and contractor should understand if the suggested method is used, it is used at their own risk. LG Electronics U.S.A., Inc., takes no responsibility and offers no warranty, expressed or implied, of merchantability or fitness of purpose if this method fails to perform as stated or intended.

• For a complete copy of Standard 62.1-2010, refer to the American Standard of Heating and Air Conditioning Engineers (ASHRAE) website at www.ashrae.org.

• For more information on how to properly size a ventilation air pretreatment system, refer to the article, "Selecting DOAS Equipment with Reserve Capacity" by John Murphy, published in the ASHRAE Journal, April 2010.

Method 1: Decoupled Dedicated Outdoor Air System (DDOAS)

Provide a separate, dedicated outdoor-air system designed to filter, condition, and dehumidify ventilation air and deliver it directly to the conditioned space through a separate register or grille. This approach requires a separate independent ventilation duct system not associated with single systems (Figure 23).

Note

LG recommends using the DDOAS method in all installations.

Advantages

- Does not add additional heating or cooling loads to indoor units.
- May be used with all single zone systems.
- If the outdoor air unit fails, the resulting untreated air will be readily noticed by the occupants.
- The outdoor air unit may supply "neutral" air to the occupant space even when the single zone system indoor unit fan changes speed or cycles on and off. DDOAS controls do not have to be interlocked with the single zone system.
- In lieu of installing localized smaller outside air treatment equipment throughout the building, this method centralizes the ventilation air source making service and filter changes easier and less disruptive for the building occupants.

- Indoor unit operation and performance will not be affected by the condition of outdoor air.
- Third-party demand control ventilation controls are more readily accommodated.

Disadvantages

- Ceiling space is required to accommodate ductwork between the centralized outdoor air unit and ceiling diffusers.

Note

Methodology illustrations are for examples only and do not depict actual indoor units for the specific outdoor unit pairing. These are generic illustrations to show ventilation design only.

Figure 23: Decoupled Dedicated Outdoor System Diagram

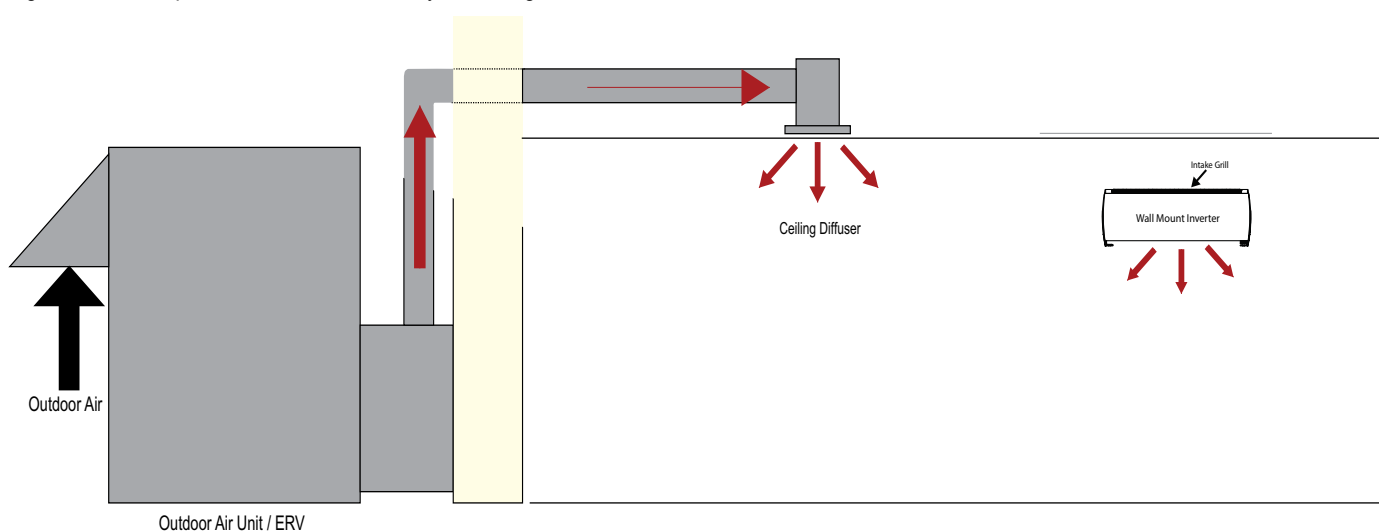

BUILDING VENTILATION DESIGN GUIDE

Method 2: Unconditioned Outdoor Air (Non-Ducted, Natural Ventilation)

Natural ventilation devices, such as operable windows or louvers may be used to ventilate the building when local code permits. The open area of a window or the free area of a louver must meet the minimum percentage of the net occupied floor area. Refer to Figure 8.

Advantages

- Occupants control the volume of the ventilation air manually.
- Useful for historic buildings that have no ceiling space available for outdoor air ductwork.
- May be used with all single zone systems.

Figure 24: Unconditioned Outdoor Air (Non-Ducted)



Disadvantages

- In some locations, it may be difficult to control humidity levels when windows are open.
- Thermal comfort levels may be substandard when windows are open.
- Indoor units may have to be oversized to account for the added heating and cooling loads when windows are open.
- Provides outdoor air to perimeter spaces only. Additional mechanical ventilation system may be required to satisfy requirements for interior spaces.
- Outdoor air loads may be difficult to calculate since the quantity of outdoor air is not regulated.
- May affect indoor unit proper operation when open.

Note

Methodology illustrations are for examples only and do not depict actual indoor units for the specific outdoor unit pairing. These are generic illustrations to show ventilation design only.

Method 3: Unconditioned Outdoor Air (Non-Ducted, Fan Assisted Ventilation)

When approved by local codes, the fan assisted ventilation method uses exhaust fans to remove air from the building, and outdoor air is drawn into occupied spaces through a wall louver or gravity roof intake hood. Supply fans can also be used to push the outdoor air into the space and building positive pressure will vent the exhaust air through louvers or roof-mounted exhaust hoods. Outdoor air is neither cooled nor heated before entering the building. Refer to Figure 24.

Note

This may result in loss of building pressurization control, increasing infiltration loads with adverse effects.

Advantages

- Outdoor air may be manually controlled by the occupant or automatic controls may be installed to open/close outdoor air dampers or to turn on/off ventilation fans.
- Useful for large open spaces like warehouses, garages, and workshops.
- Outdoor air volume is a known quantity. Air loads may be easier to calculate since fans will regulate the amount of outdoor air.
- May be used with all single zone systems.

Note

Methodology illustrations are for examples only and do not depict actual indoor units for the specific outdoor unit pairing. These are generic illustrations to show ventilation design only.

Disadvantages

- In some locations of the country, it may be difficult to control humidity levels while outdoor air louvers/hoods are opened.
- Thermal comfort levels may be substandard when louvers/hoods are opened.
- Indoor units may have to be oversized to account for the added heating/cooling loads when louvers/hoods are open.
- Hot, cold, and/or humid areas may be present if the outdoor air is not evenly distributed to the different spaces.

Figure 25: Unconditioned Outdoor Air Fan Assisted Ventilation

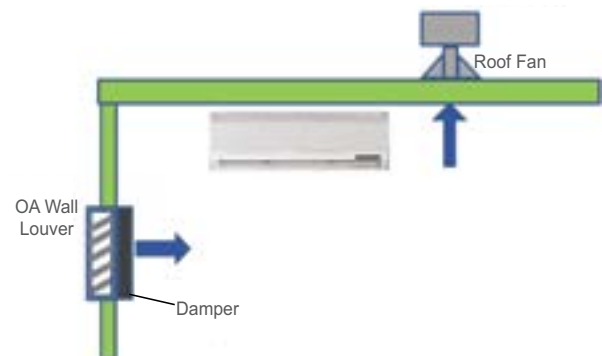

PLACEMENT CONSIDERATIONS

Selecting the Best Location

Select a location for installing the outdoor unit that will meet the following conditions:

- Where the unit will not be subjected to direct thermal radiation from other heat sources.
- Where operating sound from the unit will not disturb inhabitants of surrounding buildings.
- Where the unit will not be exposed to direct, strong winds.
- Where there is enough strength to bear the weight of the unit.
- Include space for drainage to ensure condensate flows properly out of the unit when it is in heating mode.
- Include enough space for air flow and for service access.
- To avoid the possibility of fire, do not install the unit in an area where combustible gas may generate, flow, stagnate, or leak.
- Do not install the unit in a location where acidic solution and spray (sulfur) are often used.
- Do not use the unit in environments where oil, steam, or sulfuric gas are present.
- Install a fence to prevent vermin from crawling into the unit or unauthorized individuals from accessing it.

To ensure the outdoor unit operates properly, certain measures are required in locations where there is a possibility of heavy snowfall or severe windchill or cold:

1. Prepare for severe winter wind chills and heavy snowfall, even in areas of the country where these are unusual phenomena.
2. Position the outdoor unit so that its airflow fans are not buried by direct, heavy snowfall. If snow piles up and blocks the airflow, the system may malfunction.
3. Remove any snow that has accumulated 3-15/16 inches or more on the top of the outdoor unit.
4. Place the outdoor unit on a raised platform at least 19-11/16 inches higher than the average annual snowfall for the area. In environments where there is a possibility of heavy snow, the frame height must be more than two (2) times the amount of average annual snowfall, and should not exceed the width of the outdoor unit. If the frame width is wider than the outdoor unit, snow may accumulate.
5. Install a snow protection hood.
6. To prevent snow and heavy rain from entering the outdoor unit, install the suction and discharge ducts facing away from direct winds.
7. Additionally, the following conditions should be taken into considerations when the unit operates in defrost mode:
 - If the outdoor unit is installed in a highly humid environment (near an ocean, lake, etc.), ensure that the site is well-ventilated and has a lot of natural light. (Example: Install on a rooftop.)
 - Sidewalks or parking lots near the outdoor unit may accumulate moisture after unit operates in defrost mode that can turn to ice.

The indoor unit may take longer to provide heat, or heating performance will be reduced in winter if the unit is installed:

1. In a narrow, shady location.
2. Near a location that has a lot of ground moisture.
3. In a highly humid environment.
4. In an area in which condensate does not drain properly.

PLACEMENT CONSIDERATIONS

Outdoor Unit Installation

General Mounting

Securely attach the outdoor unit to a condenser pad, base rails, or another mounting platform that is securely anchored to the ground or building structure. Attach the outdoor unit with a bolt and nut on a concrete or rigid mount. See Figure 26. Refer to the applicable installation manual and follow applicable local codes for clearance, mounting, anchor and vibration attenuation requirements.

Note

All referenced materials are to be field-supplied. Images are not to scale.

Mounting Platform

The underlying structure or foundation must be designed to support the weight of the unit. Avoid placing the unit in a low lying area where water may accumulate. When installing the outdoor unit on the wall, or roof top, anchor the mounting base securely to account for wind, earthquake or vibration.

Tie-Downs and Wind Restraints

The strength of the Duct-free Split Single Zone Inverter system frame is adequate to be used with field-provided wind restraint tie-downs. The overall tie-down configuration must be approved by a local professional engineer. Always refer to local code when designing a wind restraint system.

Snow and Ice Conditions

In climates that experience snow build-up, place the unit on a raised platform to ensure condenser airflow. The raised support platform must be high enough to allow the unit to remain above possible snow drifts. Mount the unit on a field-provided snow stand at a minimum height that is equal to the average annual snowfall plus 20 inches. Design the mounting base to prevent snow accumulation on the platform in front or back of the unit case. If necessary, provide a field fabricated hood to keep snow and ice and/or drifting snow from accumulating on the coil surfaces. Use inlet and discharge duct or hoods to prevent snow or rain from accumulating on the fan inlet and outlet guards. Best practice prevents snow from accumulating on top of the unit. Consider tie-down requirements in case of high winds or where required by local codes.

Note

When deciding on a location to place the outdoor unit, be sure to choose an area where run-off from defrost will not accumulate and freeze on sidewalks or driveways.

Ambient Air Conditions

Avoid exposing the outdoor unit to steam, combustible gases, or other corrosive elements. Avoid exposing the unit to discharge from boiler stacks, chimneys, steam relief ports, other air conditioning units, kitchen vents, plumbing vents, and other sources of extreme temperature, gases, or substances that may degrade performance or cause damage to the unit.

When installing multiple outdoor units, avoid placing units where the discharge of one outdoor unit will blow into the inlet side of an adjacent unit.

Figure 26: Outdoor Unit Mounting Methods

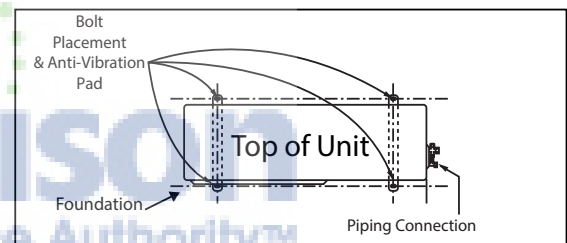
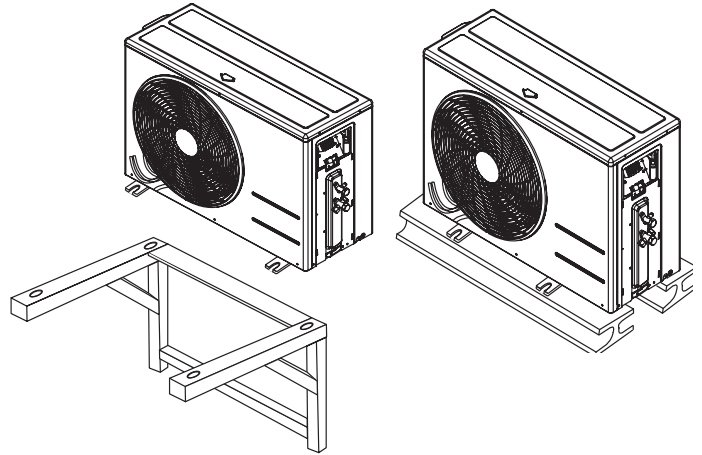

PLACEMENT CONSIDERATIONS

Outdoor Unit Installation

Outdoor Unit Clearance

Proper clearance through the outdoor coil is critical for proper unit operation. When installing the outdoor unit, consider service, inlet and outlet and minimum allowable space requirements as illustrated in the diagrams below.

Specific clearance requirements in the diagram below are for the single zone wall mount systems. Figure 27 shows the overall minimum clearances that must be observed for safe operation and adequate airflow around the outdoor unit.

Figure 27: Outdoor Unit Clearances

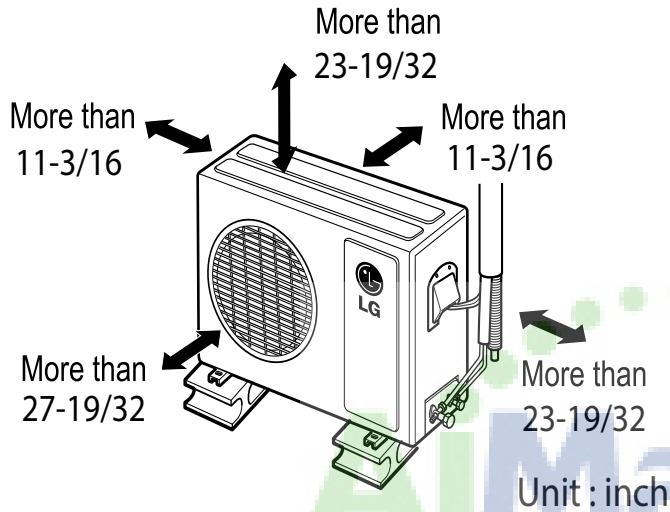
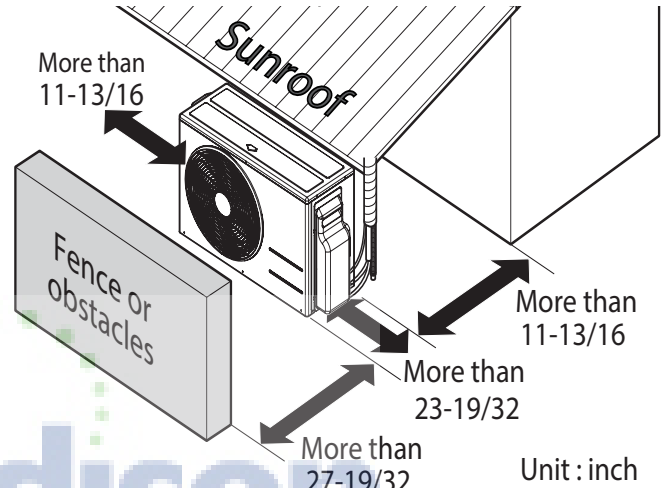

Figure 28: Outdoor Unit Sunroof/Awning Clearances



When placing the outdoor unit under an overhang, awning, sunroof or other "roof-like structure, observe the clearance requirements (as shown in Figure 27) for height in relation to the unit. This clearance ensures that heat radiation from the condenser is not restricted around the unit.

Adhere to all clearance requirements if installing the unit on a roof. Be sure to level the unit and ensure that the unit is adequately anchored. Consult local codes for rooftop mounting requirements.

Note
Do not place the unit where animals and/or plants will be in the path of the warm air, or where the warm air and/or noise will disturb neighbors.



REFRIGERANT PIPING DESIGN AND BEST LAYOUT PRACTICES

“Refrigerant Piping Design” on page 64

“Installation & Best Layout Practices” on page 66

“Electrical Connections” on page 71

800-570-3355

REFRIGERANT PIPING DESIGN

Design Guideline Summary

Device Connection Limitations

Single zone systems consist of one outdoor unit and one indoor unit. One of the most critical elements of a single zone system is the refrigerant piping. Tables 35-37 list pipe length limits that must be followed in the design of a Single Zone Wall Mount refrigerant pipe system. Refer to Figure 29 for maximum length and elevation of piping

Table 35: Single Zone High Efficiency Refrigerant Piping System Limitations.

Pipe Length (ELF = Equivalent Length of pipe in Feet)	Longest total equivalent piping length	LS091HSV3	LS121HSV3	LS181HSV3	LS240HSV3
		65.6	65.6	98.4	98.4
	Distance between fittings and indoor units or outdoor units	≥20 inches	≥20 inches	≥20 inches	≥20 inches
Elevation (All Elevation Limitations are Measured in Actual Feet)	If outdoor unit is above indoor unit	32.8	32.8	49.2	49.2
	If outdoor unit is below indoor unit	32.8	32.8	49.2	49.2
Additional Refrigerant Needed (oz/ft)		0.22	0.22	0.38	0.38

Table 36: Single Zone Standard Refrigerant Piping System Limitations.

Pipe Length (ELF = Equivalent Length of pipe in Feet)	Longest total equivalent piping length	LS307HV3	LS360HV3
		98.4	98.4
	Distance between fittings and indoor units or outdoor units	≥20 inches	≥20 inches
Elevation (All Elevation Limitations are Measured in Actual Feet)	If outdoor unit is above indoor unit	49.2	49.2
	If outdoor unit is below indoor unit	49.2	49.2
Additional Refrigerant Needed (oz/ft)		0.38	0.38

Table 37: Single Zone Extended Pipe Refrigerant Piping System Limitations.

Pipe Length (ELF = Equivalent Length of pipe in Feet)	Longest total equivalent piping length	LS240HLV	LS300HLV	LS360HLV
		164.0	164.0	164.0
	Distance between fittings and indoor units or outdoor units	≥20 inches	≥20 inches	≥20 inches
Elevation (All Elevation Limitations are Measured in Actual Feet)	If outdoor unit is above indoor unit	98.4	98.4	98.4
	If outdoor unit is below indoor unit	98.4	98.4	98.4
Additional Refrigerant Needed (oz/ft)		0.38	0.38	0.38

Figure 29: Single Zone System Layout

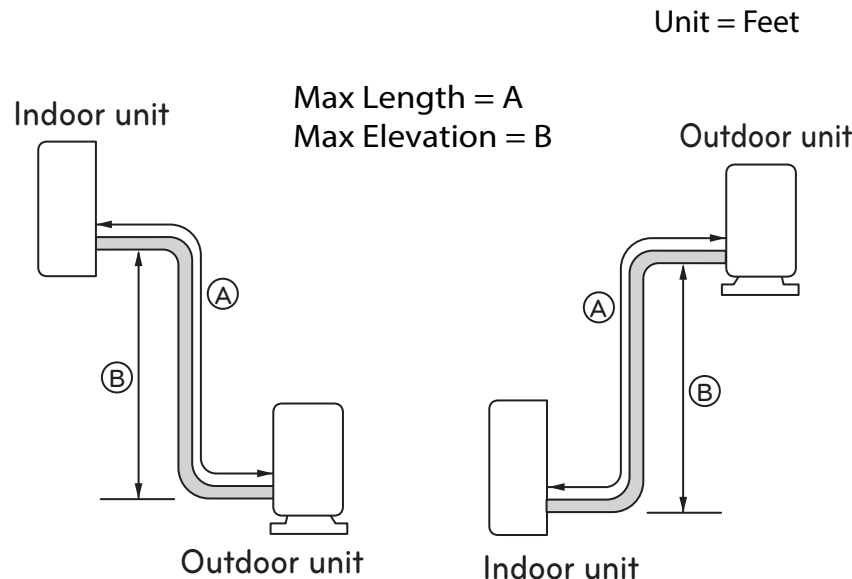

REFRIGERANT PIPING DESIGN

Selecting Field-Supplied Copper Tubing

Table 38: Linear Thermal Expansion of Copper Tubing in Inches.

Pipe Length ¹	Fluid Temperature °F																			
	35°	40°	45°	50°	55°	60°	65°	70°	75°	80°	85°	90°	95°	100°	105°	110°	115°	120°	125°	130°
10	0.04	0.04	0.05	0.06	0.06	0.07	0.08	0.08	0.09	0.09	0.10	0.10	0.11	0.11	0.11	0.12	0.13	0.14	0.15	0.15
20	0.08	0.08	0.10	0.12	0.13	0.14	0.15	0.16	0.17	0.18	0.19	0.20	0.21	0.22	0.22	0.23	0.26	0.28	0.29	0.30
30	0.12	0.12	0.15	0.18	0.20	0.21	0.23	0.24	0.26	0.27	0.29	0.30	0.32	0.33	0.32	0.35	0.39	0.42	0.44	0.45
40	0.16	0.16	0.20	0.24	0.26	0.28	0.30	0.32	0.34	0.36	0.38	0.40	0.42	0.44	0.43	0.46	0.52	0.56	0.58	0.60
50	0.20	0.20	0.25	0.30	0.33	0.35	0.38	0.40	0.43	0.45	0.48	0.50	0.53	0.55	0.54	0.58	0.65	0.70	0.73	0.75
60	0.24	0.24	0.30	0.36	0.39	0.42	0.45	0.48	0.51	0.54	0.57	0.60	0.63	0.66	0.65	0.69	0.78	0.84	0.87	0.90

¹Pipe length baseline temperature = 0°F. "Expansion of Carbon, Copper and Stainless Steel Pipe," *The Engineers' Toolbox*, www.engineeringtoolbox.com.

Figure 30: Coiled Expansion Loops and Offsets.

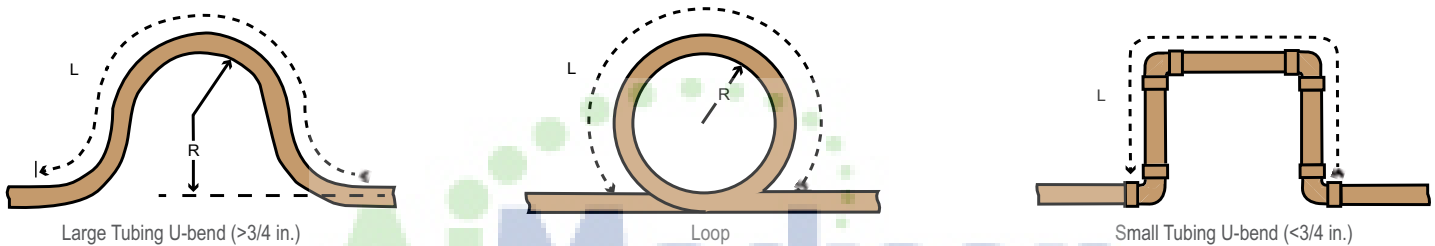

Table 39: Radii of Coiled Expansion Loops and Developed Lengths of Expansion Offsets.

Anticipated Linear Expansion (LE) (inches)		Nominal Tube Size (OD) inches			
		1/4	3/8	1/2	3/4
1/2	R ¹	6	7	8	9
	L ²	38	44	50	59
1	R ¹	9	10	11	13
	L ²	54	63	70	83
1-1/2	R ¹	11	12	14	16
	L ²	66	77	86	101
2	R ¹	12	14	16	19
	L ²	77	89	99	117
2-1/2	R ¹	14	16	18	21
	L ²	86	99	111	131
3	R ¹	15	17	19	23
	L ²	94	109	122	143
3-1/2	R ¹	16	19	21	25
	L ²	102	117	131	155
4	R ¹	17	20	22	26
	L ²	109	126	140	166

¹R = Centerline Length of Pipe.

²L = Centerline Minimum Radius (inches).

INSTALLATION & LAYOUT BEST PRACTICES

Refrigerant Piping System Layout

Definitions

Physical Pipe Length: Actual length of straight segment(s) of pipe.

Equivalent Pipe Length: Actual length of pipe plus equivalent lengths of elbows, Y-branches, and valves.

Layout Procedure

1. Draft a one-line diagram of the proposed piping system connecting outdoor unit to heat recovery and indoor units. Follow the pipe limitations listed on page 64.
2. Calculate the physical length of each pipe segment and note it on the drawing.
3. Calculate the equivalent pipe length of each pipe segment.

Using Elbows

Field-supplied elbows are allowed as long as they are designed for use with R410A refrigerant. The designer, however, should be cautious with the quantity and size of fittings used, and must account for the additional pressure losses in equivalent pipe length calculation. The equivalent pipe length of each elbow must be added to each pipe segment. See Table 40 for equivalent lengths.

Table 40: Equivalent Piping Length for Piping Components.

Component	Size (Inches)				
	1/4	3/8	1/2	5/8	3/4
Elbow (ft.)	0.5	0.6	0.7	0.8	1.2

Field-Provided Isolation Ball Valves

It is acceptable to install field-supplied ball valves with Schrader ports at the indoor unit. Full-port isolation ball valves with Schrader ports (positioned between valve and indoor unit) rated for use with R410A refrigerant should be used on both the liquid and vapor lines.

If valves are not installed and the indoor unit needs to be removed or repaired, the entire system must be shut down and evacuated. Position valves with a minimum distance of three (3) to six (6) inches of pipe on either side of the valve. Valves must be easily accessible for service. If necessary, install drywall access doors or removable ceiling panels, and position the valves to face the access door or ceiling panel opening. Mount valves with adequate space between them to allow for placement of adequate pipe insulation around the valves. Recommended best practice is to clearly label and document locations of all service valves. The equivalent pipe length of each ball valve must be added to each pipe segment.

Obstacles

When an obstacle, such as an I-beam or concrete T, is in the path of the planned refrigerant pipe run, it is best practice to route the pipe over the obstacle. If adequate space is not available to route the insulated pipe over the obstacle, then route the pipe under the obstacle. In either case, it is imperative the horizontal section of pipe above or below the obstacle be a minimum of three (3) times greater than the longest vertical rise (or fall) distance. Refer to Figure 31.

Figure 31: Installing Piping Above and Below an Obstacle

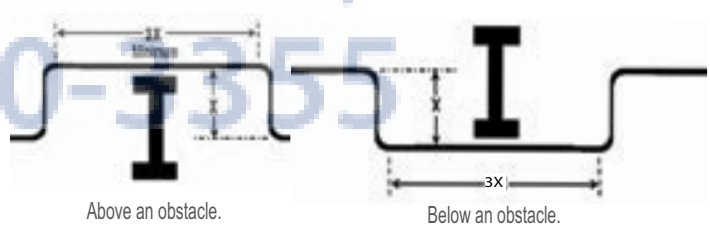

REFRIGERANT PIPING DESIGN

Refrigerant Piping System Layout

In-line Refrigeration Components

Components such as oil traps, solenoid valves, filter-dryers, sight glasses, tee fittings, and other after-market accessories are not permitted on the refrigerant piping system between the outdoor unit and the indoor unit. Single Zone Wall Mount systems are provided with redundant systems that assure oil is properly returned to the compressor. Sight-glasses and solenoid valves may cause vapor to form in the liquid stream. Over time, dryers may deteriorate and introduce debris into the system. The designer and installer should verify the refrigerant piping system is free of traps, sagging pipes, sight glasses, filter dryers, etc.

No Pipe Size Substitutions

Using a different size is prohibited and may result in a system malfunction or failure to work at all.

Pipe Supports

A properly installed pipe system should be adequately supported to avoid pipe sagging. Sagging pipes become oil traps that lead to equipment malfunction.

Pipe supports should never touch the pipe wall; supports shall be installed outside (around) the primary pipe insulation jacket (see Figure 31). Insulate the pipe first because pipe supports shall be installed outside (around) the primary pipe insulation jacket. Clevis hangers should be used with shields between the hangers and insulation. Field provided pipe supports should be designed to meet local codes. If allowed by code, use fiber straps or split-ring hangers suspended from the ceiling on all-thread rods (fiber straps or split ring hangers can be used as long as they do not compress the pipe insulation). Place a second layer of insulation over the pipe insulation jacket to prevent chafing and compression of the primary insulation within the confines of the support pipe clamp.

A properly installed pipe system will have sufficient supports to avoid pipes from sagging during the life of the system. As necessary, place supports closer for segments where potential sagging could occur. Maximum spacing of pipe supports shall meet local codes. If local codes do not specify pipe support spacing, pipe shall be supported:

- Maximum of five feet (5') on center for straight segments of pipe up to 3/4" outside diameter size.

Whenever the pipe changes direction, place a hanger within twelve (12) inches on one side and within twelve to nineteen (12 to 19) inches of the bend on the other side as shown in Figure 32.

Figure 32: Pipe Hanger Details.

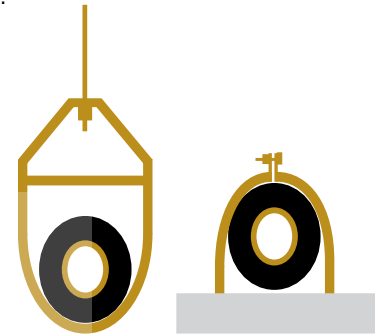

Figure 33: Typical Pipe Support Location—Change in Pipe Direction.

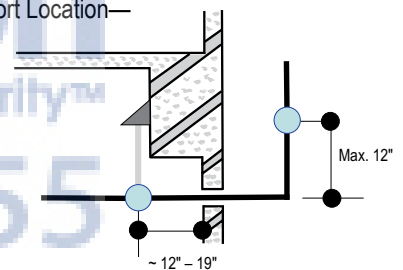
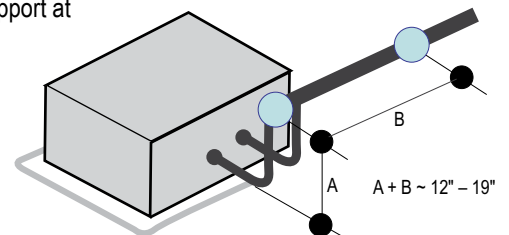

Figure 34: Pipe Support at Indoor Unit.



INSTALLATION & LAYOUT BEST PRACTICES

Refrigerant Piping System Layout

Pipe Sleeves at Penetrations

LG requires that all pipe penetrations through walls, floors, and pipes buried underground be properly insulated and routed through an appropriate wall sleeve of sufficient size to prevent compression of refrigerant pipe insulation and free movement of the pipe within the sleeve. Underground refrigerant pipe shall be routed inside a protective sleeve to prevent insulation deterioration. Refer to Figure 35.

Figure 35: Pipe Sleeve Options.

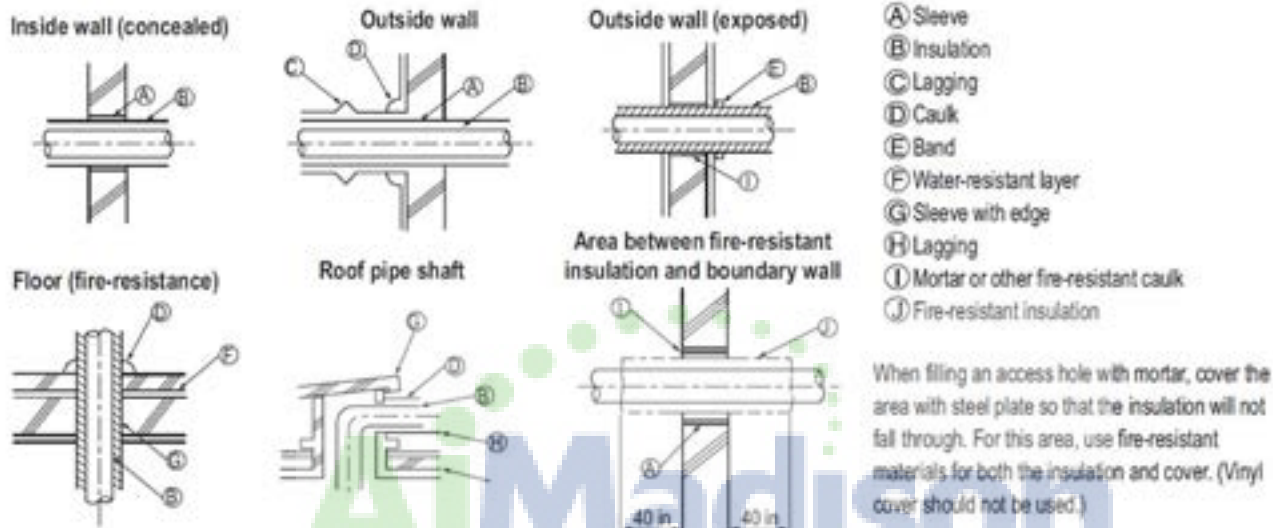

Note
Diameter of penetrations shall be determined by pipe diameter plus the thickness of the insulation.

Underground Refrigerant Piping

Refrigerant pipe installed underground should be routed inside a vapor tight protective sleeve to prevent insulation deterioration and water infiltration. Refrigerant pipe installed inside underground casing must be continuous without any joints. Underground refrigerant pipe must be located at a level **below the frost line**.

Table 41: Utility Conduit Sizes.

Liquid Pipe ¹	Vapor Pipe ¹		
	3/8 (1-1/8 ^{2,3})	1/2 (2.0 ^{2,4})	5/8 (2-1/8 ^{2,4})
1/4 (1.0) ³	4	4	4
3/8 (1-1/8) ³	4	4	4

¹OD pipe diameter in inches; Values in parenthesis () indicate OD of pipe with insulation jacket.

²Diameter of pipe with insulation. Thickness of pipe insulation is typical. Actual required thickness may vary based on surrounding ambient conditions and should be calculated and specified by the design engineer.

³Insulation thickness (value in parenthesis) = 3/8 inch.

⁴Insulation thickness (value in parenthesis) = 1 inch.

Figure 36: Typical Arrangement of Refrigerant Pipe and Cable(s) in a Utility Conduit.

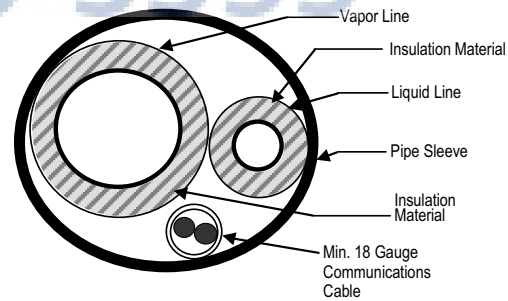

Table 42: Heat Pump Unit Refrigerant Pipe Connections (All Brazed Type)

Model	Liquid Conn. (inches)	Vapor Conn. (inches)
LSU091HSV3, LSU121HSV3	1/4	3/8
LSU181HSV3, LSU240HSV3	3/8	5/8
LSU307HV3, LSU360HV3	3/8	5/8
LSU240HLV, LSU300HLV, LSU360HLV	3/8	5/8

INSTALLATION & LAYOUT BEST PRACTICES

Piping Connection

Single Zone Wall Mount Outdoor Unit Connections

1. Remove the tubing cover by loosening the fastening screws. See Figure 37.
2. Align the center of the refrigerant pipe and corresponding connection as shown in Figure 38.
3. Place a couple of drops of refrigerant oil on the opening rim of the flare before assembling. Ensure you do not add any contaminants. Tighten the flare nut initially by hand.
4. Finish tightening the flare nut with a torque wrench until the wrench clicks. See Figure 39.

Note

When tightening the flare nut with a torque wrench, ensure the direction for tightening follows the arrow on the wrench.

Table 43: Torque Wrench Tightening

Outside Diameter (inches)	Torque (lbs-ft)
1/4	13-18
3/8	24.6-30.4
1/2	39.8-47.7
5/8	45.6-59.3
3/4	71.6-87.5

Figure 38: Pipe Attachment

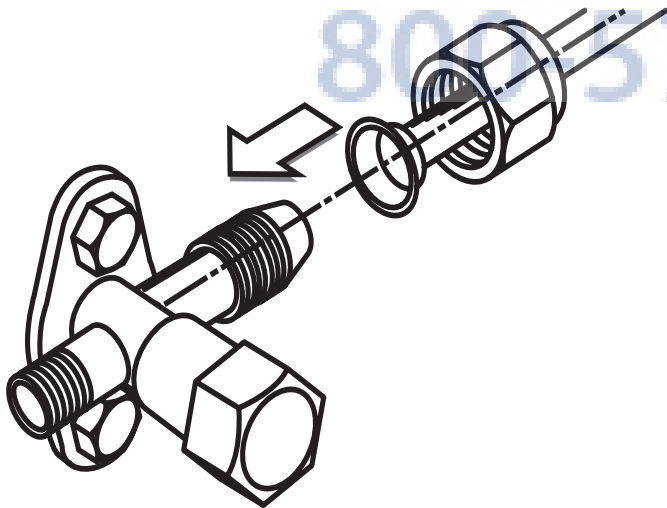

Figure 37: Outdoor Unit Connection Cover Removal

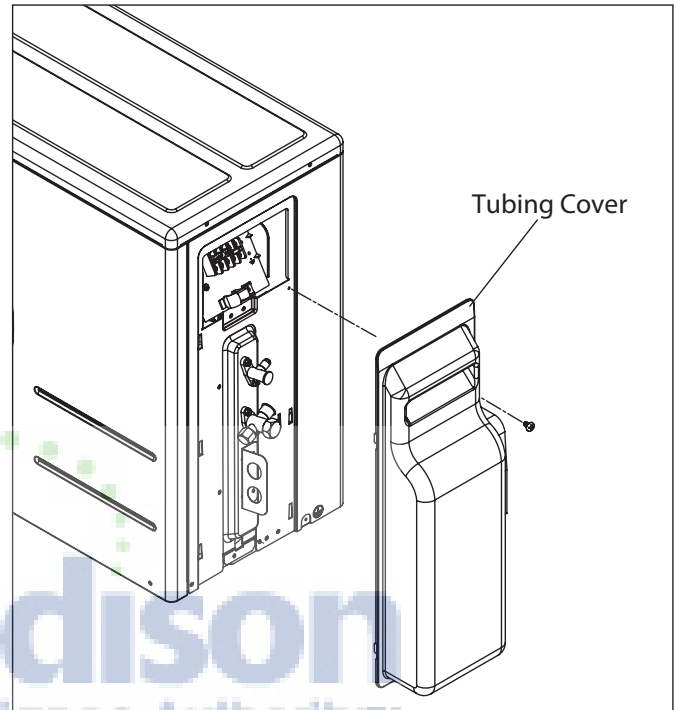
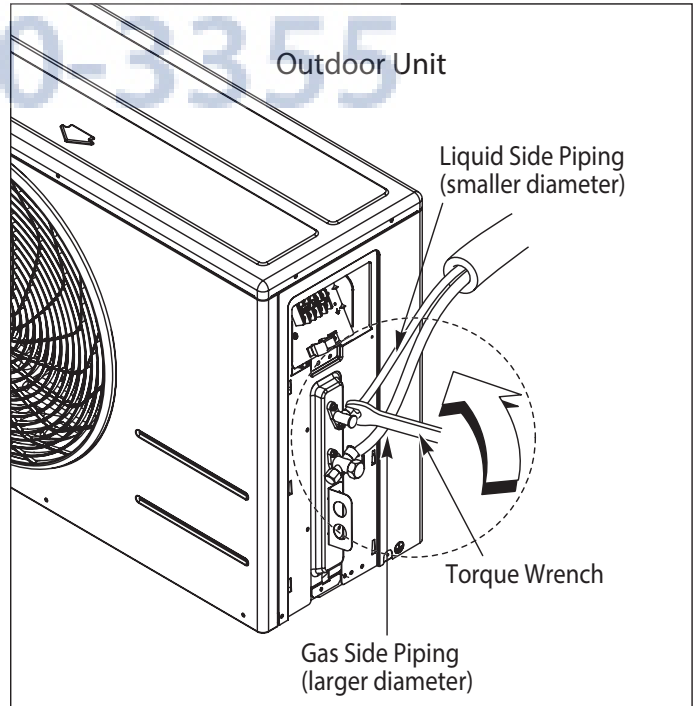

Figure 39: Heat Pump Outdoor Unit Piping Connection



INSTALLATION & LAYOUT BEST PRACTICES

Refrigerant Piping System Layout

Installation of Refrigerant Piping / Brazing Practices

Note

It is imperative to keep the piping system free of contaminants and debris such as copper burrs, slag, or carbon dust during installation.

All joints are brazed in the field. Duct-free Split Single Zone Inverter refrigeration system components contain very small capillary tubes, small orifices, electronic expansion valves, oil separators, and heat exchangers that can easily become blocked. Proper system operation depends on the installer using best practices and utmost care while assembling the piping system.

- While brazing, use a dry nitrogen purge operating at a minimum pressure of three (3) psig and maintain a steady flow.
- Blow clean all pipe sections with dry nitrogen prior to assembly.
- Use a tubing cutter, do not use a saw to cut pipe. De-burr and clean all cuts before assembly.
- Store pipe stock in a dry place. Keep pipe capped and clean.
- Use adapters to assemble different sizes of pipe.
- Do not use flux, soft solder, or anti-oxidant agents.
- Use a 15% silver phosphorous copper brazing alloy to avoid overheating and produce good flow.
- Protect isolation valves, electronic expansion valves, and other heat-sensitive control components from excessive heat with a wet rag or a heat barrier spray product

Figure 40: Refrigerant Pipe Brazing.

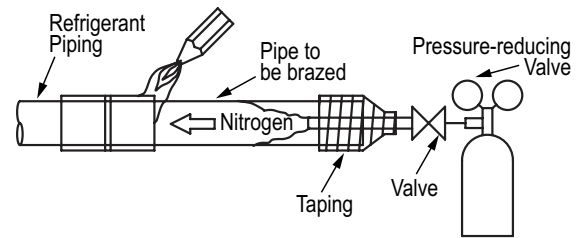

Refrigerant Piping System Insulation

All refrigerant piping including Y-branch and Header connections, field-provided isolation ball valves, service valves, and elbows shall be completely insulated using closed cell pipe insulation. The liquid and vapor lines must be insulated separately.

To prevent heat loss/heat gain through the refrigerant piping, all refrigerant piping including liquid lines and vapor lines shall be insulated separately. Insulation shall be a minimum 1/2" thick, and thickness may need to be increased based on ambient conditions and local codes.

All insulation joints shall be glued with no air gaps. Insulation material shall fit snugly against the refrigeration pipe with no air space between it and the pipe. Insulation passing through pipe hangers, inside conduit, and/or sleeves must not be compressed. Protect insulation inside hangers and supports with a second layer. All pipe insulation exposed to the sun and outdoor elements shall be properly protected with PVC, aluminum vapor barrier, or alternatively placed in a weather-resistant enclosure such as a pipe rack with a top cover; and meet local codes.

The design engineer should perform calculations to determine if the factory-supplied insulation jackets are sufficient to meet local codes and avoid sweating. Add additional insulation if necessary. Mark all pipes at the point where the insulation jacket ends. Remove the jacket. Install field provided insulation on the run-out and main truck pipes first. Peel the adhesive glue protector slip from the insulation jacketed and install the clam-shell jacket over the fitting.

Outdoor Electrical Connection

1. Remove the control cover from the unit by loosening the fastening screw. Refer to Figure 41.
2. Take off the caps on the conduit panel.
3. Connect both the power supply and low voltage lines to the corresponding terminals on the terminal block. See Figures 43-46.
4. Be sure to ground the unit by following local codes.
5. Allow for enough length (add several inches) for each wiring.
6. Secure the cable with the cord clamp.
7. Secure conduit tubes with lock nuts.
8. Reattach the control cover to the original position with the fastening screw.

Note

Always use a circuit breaker or time delay fuse when connecting electrical wiring to the unit.

⚠ WARNING

- Comply with local codes while running wire from the indoor unit to the outdoor unit.
- Ensure you connect the wire firmly.
- Separately wire the high and low voltage lines.
- Use heat-proof electrical wire capable of withstanding temperatures up to 167°F.
- Use outdoor and waterproof connection cable rated up to 300V for the connection between the indoor and outdoor unit.
- Do not allow wire to touch refrigerant tubing, the compressor or any moving parts.

Figure 41: Outdoor Unit Connection

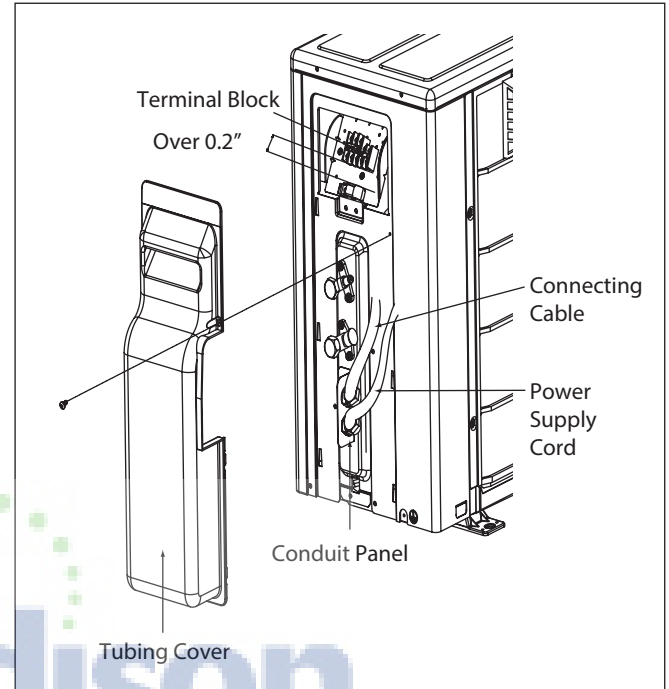
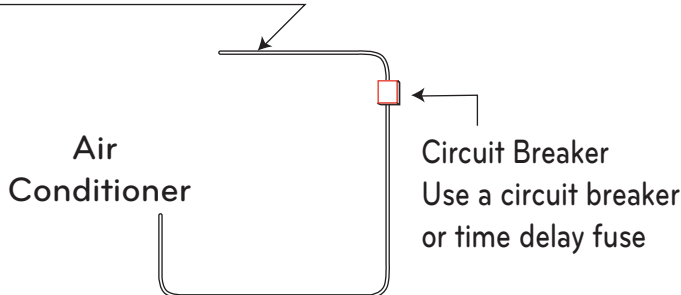

Figure 42: Circuit Breaker

Main Power Source



AiMadison
 Appliance Authority™
 800-570-3355

ELECTRICAL CONNECTIONS

Figure 43: Terminal Block Wiring Diagram - LSU091HSV3, LSU121HSV3

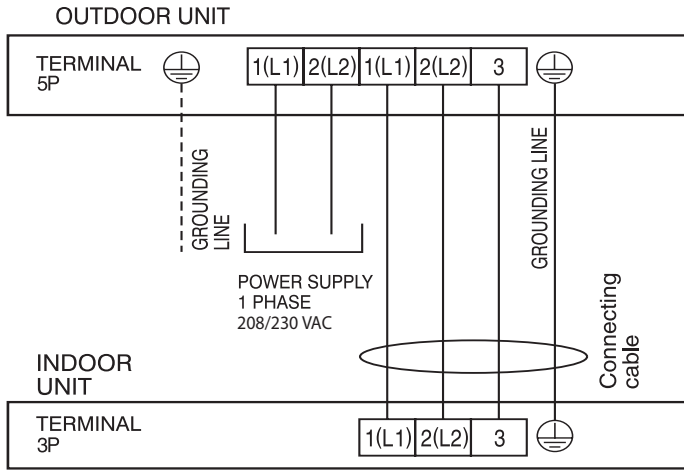

Figure 44: Terminal Block Wiring Diagram - LSU181HSV3, LSU240HSV3

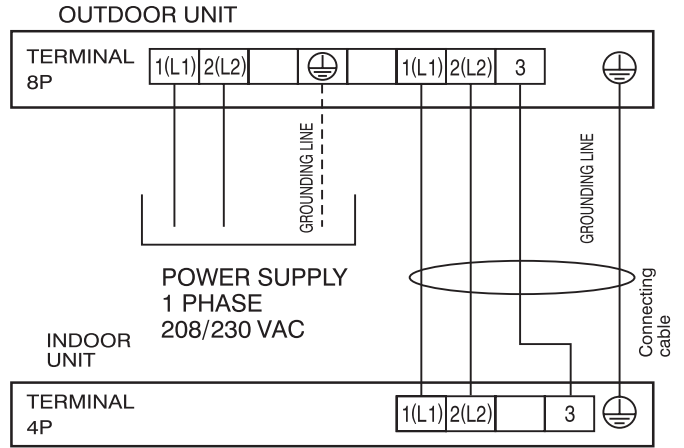

Figure 45: Terminal Block Wiring Diagram - LSU307HV3, LSU360HV3

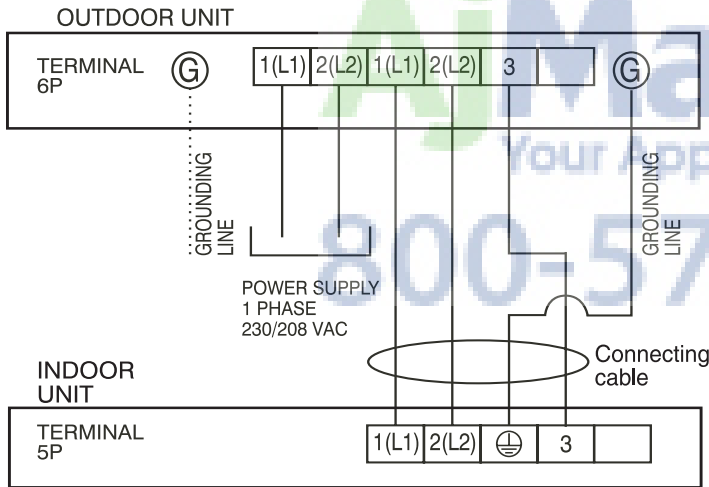
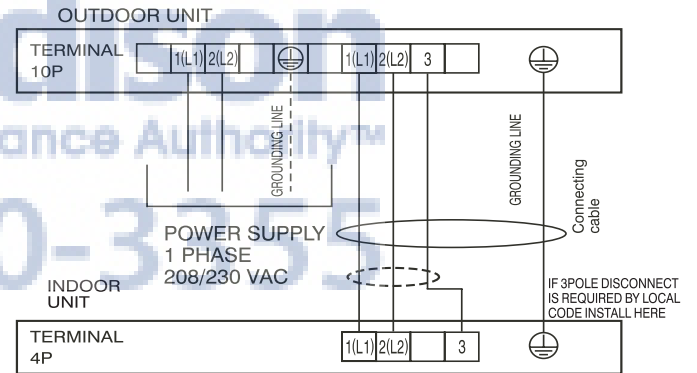

Figure 46: Terminal Block Wiring Diagram - LSU240HLV, LSU300HLV, LSU360HLV



TECHNICAL DATA

“Mechanical Specifications” on page 74

“Acronyms” on page 75



MECHANICAL SPECIFICATIONS

General

LG Single Zone High Efficiency, Single Zone Standard and Single Zone Extended Pipe systems are comprised of a single outdoor unit connected to a single indoor unit with a single refrigerant circuit.

These single zone systems can operate in either cooling or heating mode. These systems are capable of changing mode within a maximum time of three (3) minutes to ensure temperature can be properly maintained.

LG components are manufactured in a facility registered to ISO 9001 and ISO 14001, which is a set of standards applying to environmental protection set by the International Organization for Standardization (ISO). The units are listed by Intertek Electrical Testing Laboratories (ETL) and bear the ETL label. Wiring in these units are in accordance with the National Electrical Code (NEC).

Temperature Ranges

Outdoor Unit

Operating ranges for outdoor units of 14°F to 118°F DB for cooling and -4°F to 75°F WB for heating.

Indoor Unit

Operating ranges for indoor units of 64°F to 90°F WB for cooling and 60°F to 86°F DB for heating.

Installing an optional Low Ambient Wind Baffle Kit will allow operation down to 0°F in cooling mode for all single zone systems.

Casing / Frame

Outdoor unit is constructed with pre-coated metal (PCM).

Indoor unit is constructed of heavy duty Acrylonitrile Butadiene Styrene (ABS) and High Impact Polystyrene (HIPS) plastic.

Refrigerant System

The refrigeration system consists of a single refrigeration circuit and uses R410A refrigerant. The outdoor unit is provided with factory

installed components, including a refrigerant strainer, four-way reversing valve, electronic controlled expansion valve (EEV), high and low side charging ports, service valves, and interconnecting piping.

Refrigeration Oil Control

Heat pump outdoor units have a centrifugal oil separator and controls to ensure sufficient oil supply is maintained, and that oil does not travel with the refrigerant.

Compressors

The outdoor unit is equipped with one hermetic digitally controlled inverter driven rotary (9k/12k Btu/h systems) or twin rotary (18k/24k/30k/36k Btu/h systems) compressor to modulate capacity (modulation in 1 Hz increments).

Frequency ranges for the outdoor units are as follows:

LSU091HSV3, LSU121HSV3, LSU181HSV3 = 15-100 Hz

LSU240HSV3 = 20-100 Hz

LSU307HV3, LSU360HV3 = 20-100 Hz

LSU240HLV, LSU300HLV, LSU360HLV = 10-100 Hz.

Overcurrent protection and vibration isolation are integrated with the compressor.

Outdoor Unit Coil

Heat pump outdoor unit coils are made of a nonferrous construction with louvered fins on copper tubing, and are protected with an integral coil guard. Coil fans have a factory applied corrosion resistant GoldFin™ material with hydrophilic coating.

Fans and Motors

The outdoor unit includes one direct fan drive, variable speed variable speed propeller type fan.

The Brushless Digitally Controlled (BLDC) fan motor shall have inherent protection, permanently lubricated bearings, and variable speed with a maximum speed up to

950 rpm. Raised guards are provided to limit contact with moving parts.

The outdoor unit has horizontal discharge airflow.

Electrical

These units are available in 208-230V, 60 Hz, 1-phase power supply. These units are capable of operating within voltage limits of $\pm 10\%$ rated voltage, and include overcurrent protection.

Controls

These units are factory wired with necessary electrical components, integral microprocessors, printed circuit boards, thermistors, sensors, terminal blocks, and lugs for power wiring.

Microprocessor-based algorithms provide component protection, soft-start capability, refrigeration system pressure, temperature, defrost, and ambient control.

ACRONYMS

Table 44: Table of Acronyms.

ABS	Acrylonitrile Butadiene Styrene	H/M/L	High/Medium/Low
AC	Air Conditioner	HVAC	Heating, , Ventilation and Air Conditioning
ACP	Advanced Control Platform	IDU	Indoor Unit
ASHRAE	American Society of Heating, Refrigeration, and Air Conditioning	ISO	International Organization for Standardization
AWG	American Wire Gauge	kW	Kilo Watts
BLDC	Brushless Digitally Controlled/Direct	LED	Light Emitting Diode
Btu/h	British Thermal Units per hour	MBh	Thousands BTUs per hour
BUS	Binary Unit System	MCA	Maximum Circuit Ampacity
CFM	Cubic Feet per Minute	MOP	Maximum Overcurrent Protection
COP	Coefficient Of Performance	ODU	Outdoor Unit
CR	Combination Ratio	PCB	Printed Circuit Board
DB	Dry Bulb	PCM	Pre-Coated Metal
dB(A)	Decibels with "A" frequency weighting	PDI	Power Distribution Indicator
DDOAS	Decoupled Dedicated Outdoor Air	PI	Power Input
DO	Digital Output	PTAC	Packaged Terminal Air Conditioner
DPST	Double-Pole Single-Throw (switch)	PVC	Polyvinyl Chloride
EEV	Electronic Expansion Valve	USB	Universal Serial BUS
ELF	Equivalent Length in Feet	VAC	Voltage Alternating Current
ESP	External Static Pressure	VAV	Variable Air Volume
ETL	Electronic Testing Laboratories	VRF	Variable Refrigerant Flow
HIPS	High Impact Polystyrene	WB	Wet Bulb

Inverter



LG Electronics
Commercial Air Conditioning Division
11405 Old Roswell Road
Alpharetta, Georgia 30009
www.lghvac.com
www.lg-dfs.com

LG Electronics Commercial Products Support
1-888-865-3026 USA
Follow the prompts for commercial A/C products.