

LIEBHERR

Design Guide 2008
Fully Integrated Models 24" and 48"

Liebherr's engineering excellence in Germany provides the largest selection of freezers, refrigerators and wine refrigerators worldwide.

Liebherr appliances consistently specializes in the manufacturing of high quality freezers and refrigerators. With more than 300 basic models, we have the widest selection in the world. Liebherr appliances feature premium quality, numerous innovative product ideas and advanced design. Liebherr freezers and refrigerators are manufactured at three modern production plants:

Liebherr Marica in Bulgaria, Liebherr-Hausgeräte Ochsenhausen GmbH in Germany and the Liebherr-Hausgeräte Lienz GmbH in Austria.

We produce more than 2.3 million quality freezers, refrigerators and wine refrigerators each year, and these are sold all over the world. Liebherr-Hausgeräte Ochsenhausen GmbH in Germany makes over 1,100,000 appliances a year and employs 1,900 people. The Liebherr-Hausgeräte Lienz GmbH manufactures more than 700,000 freezers and refrigerators and employs 1,500 people.

The appliances for the North American market are produced in Austria and in Germany.

Liebherr is committed to the protection of the environment and recognizes it as a critical priority. To guarantee an optimum and consistent implementation, all ecological aspects were observed and integrated into the quality control of Liebherr in compliance with DIN EN ISO 9001.

Liebherr's Commitment to the Environment

The components of Liebherr products can be recycled when the necessary resources are applied. A concern for the environment and a desire to protect resources has led to increased levels of recycling year after year. When Liebherr manufactures products, it is essential that the recyclable recovery rate of the materials we use constantly increases.

Recycling is a common goal among all manufacturers, municipalities and recycling companies to protect our environment. Protecting the environment and producing products which have a low impact on the environment, is one of Liebherr's core values. Whether you are replacing a unit or starting fresh, remember to dispose of your old appliance in an environmentally safe and friendly manner.

Introduction

LIEBHERR WARRANTY PLAN

FULL TWO YEAR WARRANTY - For two years from the date of original purchase, your Liebherr Warranty covers all parts and labor to repair or replace any part of the product which proves to be defective in materials or workmanship.

FULL FIVE YEAR WARRANTY - For five years from the date of original purchase, your Liebherr Warranty covers all parts and labor to repair or replace any components that prove to be defective in materials or workmanship in the sealed system. The "Sealed System" means only the compressor, condenser, evaporator, drier and all connecting tubing.

LIMITED 6TH THROUGH 12TH YEAR WARRANTY - From the 6th through 12th year from the date of original purchase, your Liebherr Warranty covers all parts that prove to be defective in materials or workmanship in the sealed system (parts only).



Customer Service

If your appliance is not working properly, or if the temperature display reads "F0" to "F5", please call the numbers listed below.

Give the **fault number displayed**, together with the **Type Designation, Service Number** and **Appliance Number (Serial Number)**

from the model plate, to ensure prompt, accurate servicing. The model plate is located inside the appliance.

Leave the appliance door closed until the customer service technician arrives to minimize any further cold loss.

For Service and Parts in the U.S.: Liebherr Service Center

15545 N. 77th Street
Scottsdale, AZ 85260

Phone: (480) 998-0141
Fax: (480) 998-7877
Toll Free: **1-866-LIEBHERR or
1-866-543-2437**

www.liebherr-appliances.com

For Service and Parts in Canada: Euro-Line Appliances

2278 Speers Rd.
Oakville, Ontario, L6L 2X8

Phone: (905) 829-3980
Fax: (905) 829-3985
Toll Free: **1-888-Liebherr,
1-888-543-2437**

www.euro-parts.ca

Contents

General Remarks

| | |
|----------------------------------|-----|
| Safety Warnings | I |
| Electrical Requirements & Safety | II |
| IceMaker (if equipped) | III |
| Area Requirements | IV |
| Safety Regulations | V |

Fully Integrated Models

| | |
|--|---|
| 24" and 48" Models: HC 1001 / HC 1050, SBS 20H0 HC 1011 / HC 1060, SBS 20H1 | 1 |
| Ventilation Requirements | 3 |
| Kitchen Cabinet Base Grille | 4 |
| Unit Dimensions | 5 |
| Kitchen Cabinet Doors | 6 |
| Definition of the Door Panel Heights | 7 |

General Remarks

I. Safety Warnings

PLEASE READ AND FOLLOW THESE INSTRUCTIONS

This design guide contains Warning and Caution statements. This information is important for safe and efficient installation.

This design guide is not replacing the use and care manual which contains important information on how to use Liebherr appliances.

Always read and follow all Warning and Caution statements!

WARNING

States a hazard that may cause serious injury or death if precautions are not followed.

CAUTION

Signals a situation where minor injury or product damage may occur if you do not follow instructions.

DANGER

States a hazard that will cause serious injury or death if precautions are not followed.

IMPORTANT

This highlights information that is especially relevant to a problem-free installation.

Make sure incoming voltage is the same as the unit rating.

To reduce the risk of fire, electric shock, or personal injury, the installation work and electrical wiring must be done by a qualified electrician in accordance with all applicable codes and standards, including fire rated construction.

To the Installer

It is very important that the guidelines and instructions are followed in this design guide to ensure proper installation and operation of the unit. The Installation Guidelines section contains important information for making sure the installation is correct. Read and understand all the information and installation guidelines in this manual before the unit is installed.

It is also very important to **know** the Safety Information.

General Remarks

II. Electrical Requirements & Safety

A 115 Volt, 60 Hz, 15 Amp (20 Amp for side-by-side installation) fused electrical supply is required. Connect an undercounter wine cabinet to a 115 VAC, 10 amp (15 Amp for side-by-side installations) circuit that is controlled by a circuit breaker or fuse.

We recommend using a dedicated circuit for these appliances to prevent electrical overload. Comply with the National Electrical Code as well as local codes and ordinances when installing the receptacle.

WARNING

Do not ground to a gas pipe. Check with a qualified electrician if you are not sure the appliance is properly grounded. Do not have a fuse in the neutral or grounding circuit.

WARNING

ELECTROCUTION HAZARD

Electrical Grounding Required. This appliance is equipped with a three-prong(grounding) polarized plug for your protection against possible shock hazards.

- **DO NOT remove the round grounding prong from the plug.**
- **DO NOT use a two-prong grounding adapter.**
- **DO NOT use an extension cord to connect power to the unit.**
- **DO NOT use a power cord that is frayed or damaged.**

III. IceMaker (if equipped)

The icemaker is located in the freezer compartment. It must be connected to the water supply to function properly. The appliance must be level for the icemaker to function properly.

The water pressure must be between 21.8-87.0 psi (1.5-6 bar). Use a 1/4" OD copper line (not supplied) to connect the water supply to the solenoid valve.

If you have hard water, we recommend you install a water softener. Also, a filter must be installed if the water contains solids such as sand. All equipment and devices used to supply the water to the appliance must comply with the current regulations for your geographical area.

Safety Instructions and Warnings

- Do not attach the water source while the appliance is connected to an electrical outlet.
- A shut-off valve, must be installed between the hose line and the main water supply so that the water supply can be stopped if necessary. Do not install the shut-off valve behind the refrigeration unit.
- The connection to the water supply may only be made by a trained and licensed plumber.
- The water quality must comply with the drinking water regulations for the geographical area where the appliance is located.
- The icemaker is designed exclusively to make ice cubes in quantities needed by a household and may only be operated with water appropriate for this purpose.
- All repairs and work on the icemaker may only be done by customer service personnel or other trained personnel.
- The manufacturer cannot accept liability for damage caused by equipment or water lines between the solenoid valve and the water supply.

General Remarks

IV. Area Requirements

Verify the following:

- Floors can support refrigerator's weight plus approximately 1200 pounds (544 kg) of food weight. Not all Liebherr products are designed for 1200 pounds (544 kg) of food. Some units are smaller and total weights may vary.
- Finished kitchen floor height is level. Refrigerator must be shimmed to the floor level, or levelled, to make sure, air vents are not obstructed.
- Remove anything attached to the rear or side walls that can obstruct refrigerator opening.
- Cutout dimensions are accurate.
- Electrical outlet is in correct location.

Do not install this unit next to any other refrigerator or freezer except another Liebherr model. Liebherr models are designed to allow side by side installation. They are equipped with a heating system to eliminate condensation when units are installed side by side. Installing this unit next to any other refrigerator or freezer can cause condensation or cause damage to the Liebherr unit.



CAUTION

To protect the refrigerator from possible damage, allow the appliance to stand 1/2 to 1 hour in place before turning the electricity on. This allows the refrigerant and system lubrication to reach equilibrium.

Blocking For Safety

The anti-tip brackets must be installed to prevent the unit from tipping after it is installed.

V. Safety Regulations

The appliance complies with UL250 and CAN/CSA-C 22,2 No. 63 and is designed to cool, freeze, store food as well as make ice (if equipped). It is designed as a household appliance. If used commercially, the relevant regulations on commercial use must be observed.

The appliance is set to operate within specific ambient temperature limits according to its climate rating. These temperature limits should not be exceeded. The correct climate rating for your appliance is indicated on the model plate.

This is explained as follows:

| Climate Rating | Set for Ambient Temperatures of |
|----------------|---------------------------------|
| SN | 50°F to 90°F (10°C to 32°C) |
| N | 61°F to 90°F (16°C to 32°C) |
| ST | 61°F to 101°F (16°C to 38°C) |
| T | 61°F to 110°F (16°C to 43°C) |
| SN-ST | 50°F to 101°F (10°C to 38°C) |
| SN-T | 50°F to 110°F (10°C to 43°C) |

- The refrigerant circuit has been tested for leaks.

24" and 48" Models: HC 1001 / HC 1050, SBS 20H0 HC 1011 / HC 1060, SBS 20H1

Integrated units are the most stylish option available - they're totally out of sight, fully concealed behind a cabinet door. Installed in a tall kitchen cupboard, the refrigerator door simply opens in unison with the cupboard door.

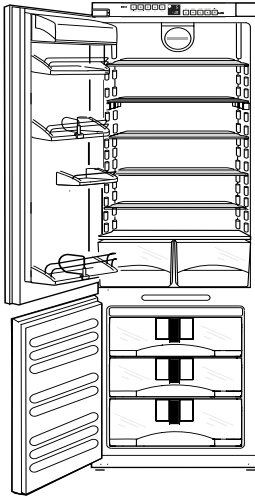

HC 1001 / HC 1011

| | |
|---------------------------|-------------------|
| Energy Star: | qualified |
| Energy consumption p. a.: | 407 kWh |
| Energy Supply: | 115V/60Hz/180W |
| Total capacity: | 9.3 cu ft (266 L) |
| Refrigerator: | 7.0 cu ft (200 L) |
| Freezer: | 2.3 cu ft (66 L) |
| Climate Rating: | SN-T |
| Door hinges: | left / reversable |

- Automatic refrigerator defrosting
- Automatic freezer compartment defrosting
- HC 1011 with soft closing system and LED-lighting

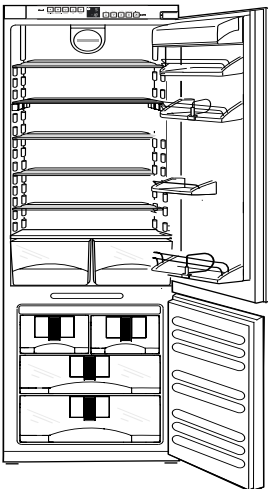

HC 1050 / HC 1060

| | |
|---------------------------|--------------------|
| Energy Star: | qualified |
| Energy consumption p. a.: | 407 kWh |
| Energy Supply: | 115V/60Hz/180W |
| Total capacity: | 9.3 cu ft (266 L) |
| Refrigerator: | 7.0 cu ft (200 L) |
| Freezer: | 2.3 cu ft (66 L) |
| Ice cube capacity: | 2.2 pd./24h |
| Ice cube stock: | 3.3 pd. |
| Climate Rating: | SN-T |
| Door hinges: | right / reversable |

- Automatic refrigerator defrosting
- Automatic freezer compartment defrosting
- Automatic IceMaker can be switched off
- HC 1060 with soft closing system and LED-lighting

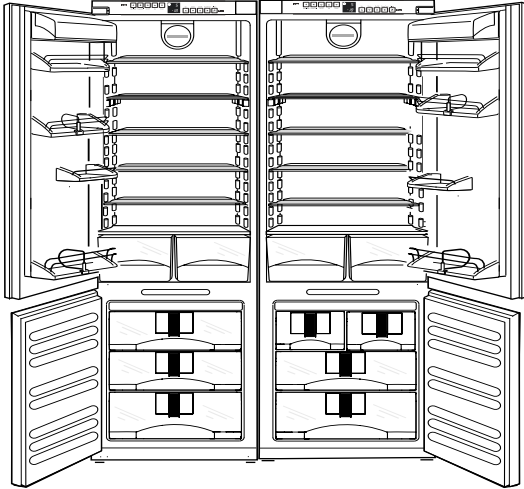

SBS 20H0 (HC 1001 & HC 1050)

| | |
|--------------------|--------------------|
| Energy Supply: | 115V/60Hz/360W |
| Total capacity: | 18.6 cu ft (532 L) |
| Refrigerator: | 14.0 cu ft (400 L) |
| Freezer: | 4.6 cu ft (132 L) |
| Ice cube capacity: | 2.2 pd./24h |
| Ice cube stock: | 3.3 pd. |
| Climate Rating: | SN-T |
| Door hinges: | left / right |

- Automatic refrigerator defrosting
- Automatic freezer compartment defrosting
- Automatic IceMaker can be switched off

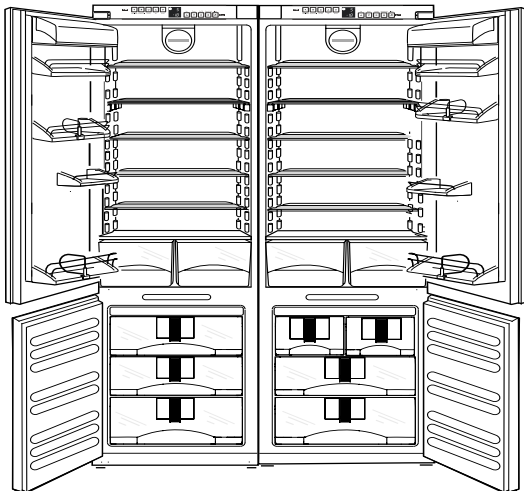

SBS 20H1 (HC 1011 & HC 1060)

| | |
|--------------------|--------------------|
| Energy Supply: | 115V/60Hz/360W |
| Total capacity: | 18.6 cu ft (532 L) |
| Refrigerator: | 14.0 cu ft (400 L) |
| Freezer: | 4.6 cu ft (132 L) |
| Ice cube capacity: | 2.2 pd./24h |
| Ice cube stock: | 3.3 pd. |
| Climate Rating: | SN-T |
| Door hinges: | left / right |

- Automatic refrigerator defrosting
- Automatic freezer compartment defrosting
- Automatic IceMaker can be switched off
- SBS 20H1 with soft closing system and LED-lighting

Ventilation Requirements

This is a fully integrated refrigerator-freezer which means that it is fully enclosed by a kitchen cabinet. This type of cabinet must be carefully constructed using the correct dimensions and it must provide suitable ventilation to ensure proper appliance operation.

Kitchen Cabinet Airflow

1. The following ventilation dimensions must be observed:

There must be a ventilation space at least 31 in.² (200 cm²) at the airflow inlet (1) and at the airflow outlet (2).

The top ventilation space can be directed in one of the following ways:

- A) Directly over the appliance (2) with either an optional factory air vent or custom made one using the template supplied with the unit.
- B) Above the cabinet and below the ceiling (3).
- C) Through a vent installed in a soffit (4).

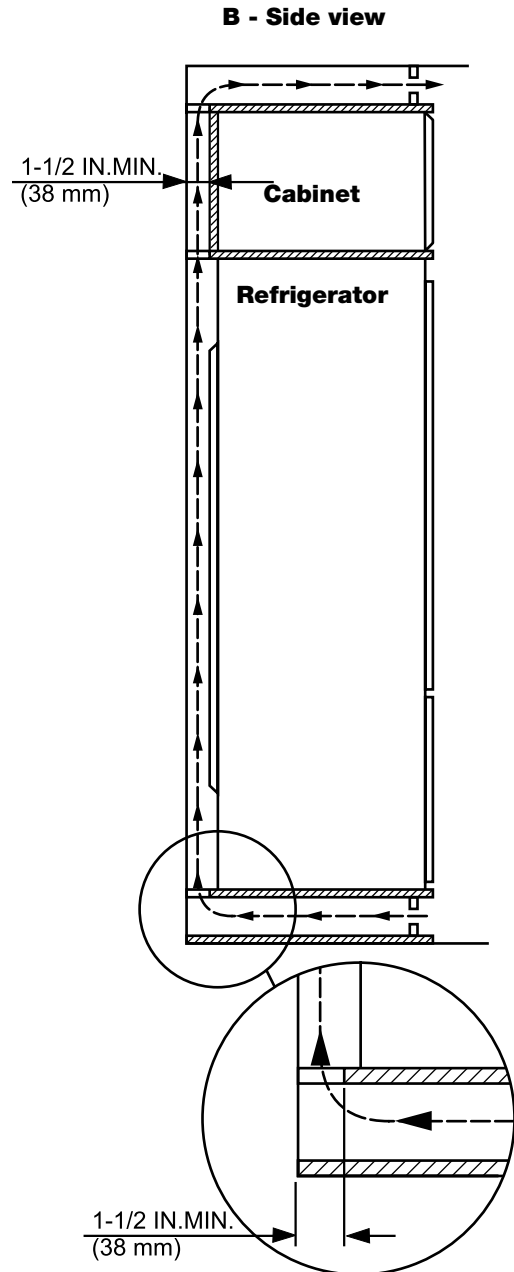
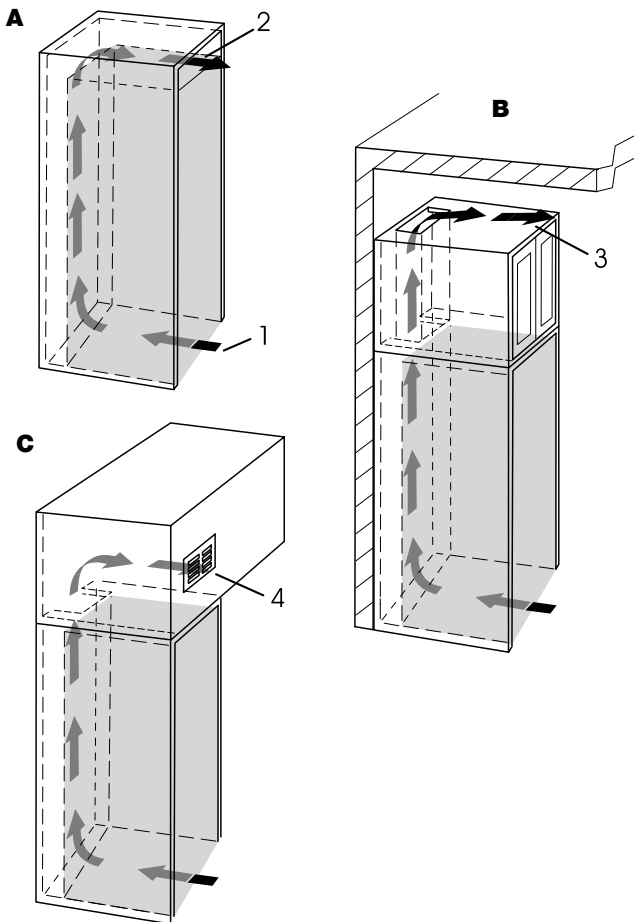

A minimum space of 1 1/2" is required when a cabinet is built above and/or underneath.

Kitchen Cabinet Base Grille

Ventilation through the cabinet base at the bottom can be achieved by installing the provided ventilation grille (3) or via a ventilation opening of at least 31 in.² (200 cm²).

When using the provided ventilation grille (3), please proceed as follows:

- In the cabinet base, cut out a ventilation opening that is 17-23/32 in. (450 mm) in width and 2-7/32 in. (56 mm) in height.
- Insert ventilation (3) grille into the cabinet base cut-out (1).
- From the back side, slide the snap-fits (2) into the grille until the hooks make contact with the cabinet base.
- Completely mount cabinet base (with ventilation grille and snap-fits) to kitchen cabinet.

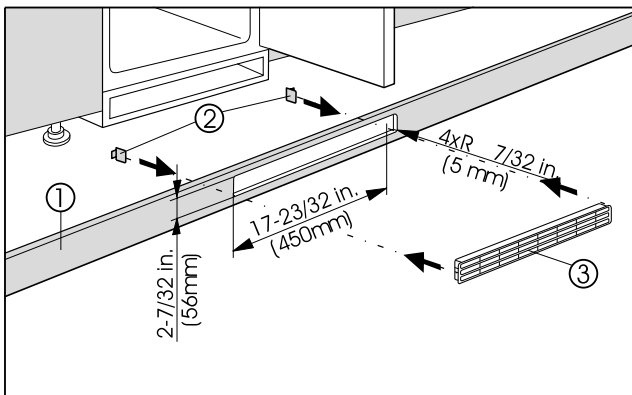

Unit Dimensions

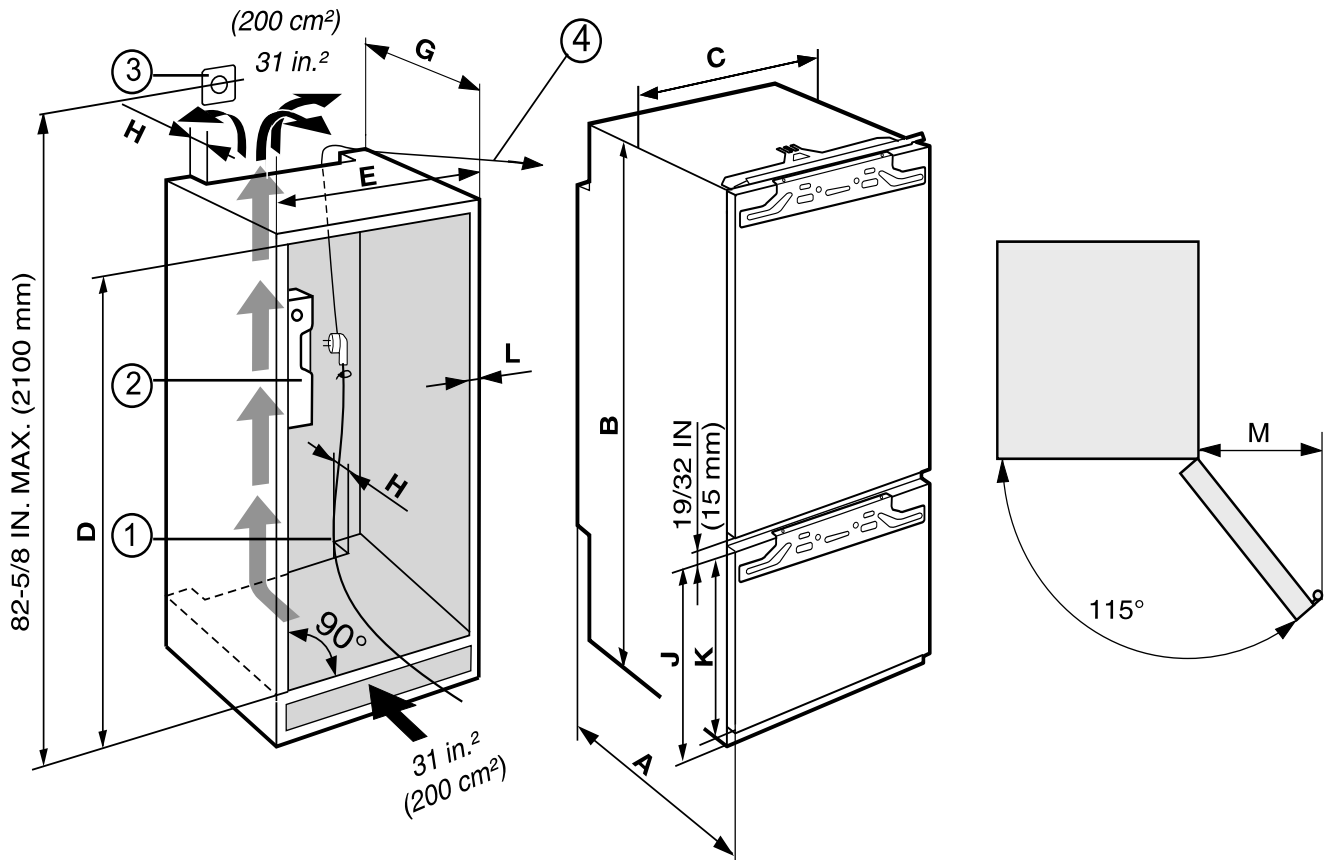

- | | |
|--|---|
| <p>A 21-7/32" (539 mm)</p> <p>B 69-43/64" (1769,5 mm)</p> <p>C 21-15/16" (557 mm)</p> <p>D 69-3/4" - 70-25/64" (1772 - 1788 mm)</p> <p>E 24" (609,6 mm, American Style Cabinet) 23-5/8" (600 mm, European Style Cabinet)</p> <p>G 21-21/32" (550 mm)</p> <p>H 1-1/2" (38 mm)</p> <p>J 27-23/64" (695 mm)</p> <p>K 24-3/4" (629 mm)</p> <p>L max. 3/4" (19 mm)</p> <p>M 9-21/32" (245 mm) Follow the distance M to the wall to allow the drawers to be pulled out properly.</p> | <p>① Power cord</p> <p>② Level</p> <p>③ Electrical outlet, The top of the electric outlet must be located within 82-5/8 in. (2100 mm) (Figure 2) from the top of the base in the cabinet.</p> <p>④ Fish line for power cord</p> |
|--|---|

Kitchen Cabinet Doors

Designing the Kitchen Cabinet Doors

You will need two doors for the kitchen cabinet, one on top for the refrigerator compartment, and one on the bottom for the freezer compartment. In general, the doors have these characteristics:

- The doors should be at least 5/8 in. (16 mm) thick to allow the connecting rails to be fastened to them.
- With both doors closed, there should be a minimum of 1/8 in. (3 mm) between the upper and lower doors(2). Also, there should be a 1/8 in. (3 mm) clearance between the upper door and the cabinet door(1) above it (if any).
- The top edge of the upper door (1) and lower door (2) should be even with the doors of adjoining cabinet(s), if any.
- The position of the joint between the kitchen cabinet doors must be level with the position of the joint between the appliance doors (2).
- Adjust the door alignment before installing the appliance. It is impossible to adjust the door with the appliance installed.
- Check the installation dimensions according to Section "Unit Dimensions".
- Do not load the door with more than 35 lbs (16kg) of food.
- Before assembling the unit door, make sure that the permitted weight for the unit doors is not exceeded. Otherwise damage to the hinges and malfunctions arising from this cannot be ruled out.

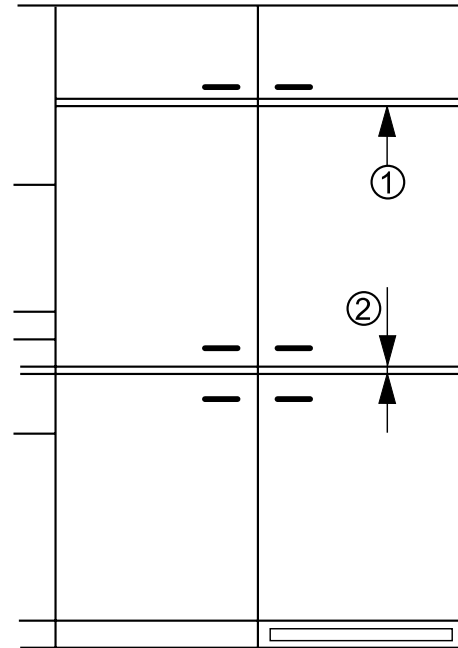

| | Maximum weight of unit door |
|--------------------------|-----------------------------|
| Fridge compartment door | 30.5 lbs (14 kg) |
| Freezer compartment door | 26.5 lbs (12 kg) |

Definition of the Door Panel Heights:

1. Start with the lower door of the freezer compartment:
The freezer door height is 24-24/32" (629 mm). In order to cover the lower part of the appliance, increase the height of the panel to 27-23/64" (695 mm).
2. To cover the face side of the floor board (a) add the thickness of the floor board (usually 3/4" (19 mm)).
Thus, the minimum height of the freezer door panel is:
 $27-23/64" + 3/4" = 28-7/64"$
(695 mm + 19 mm = 714 mm)
3. Without door panels on the unit, there is a gap of 19/32" (15mm) between the freezer door and the refrigerator door.
After the installation of the cabinet doors, the gap between the two doors will only be around 1/8" (3mm).
4. If there is other furniture standing close to the refrigerator cabinet (See also previous page) this furniture typically has a gap between two drawers or two doors. Depending on your kitchen, these gaps are approximately 1/8" (3 mm) wide.
5. In this case, the maximum height of the freezer door panel is:
 $27-23/64" + 3/4" + 19/32" - 1/8" = 28-19/32"$
(695 mm + 19 mm + 15 mm - 3 mm = 726 mm)
Where as the minimum height of the freezer door panel is:
 $27-23/64" + 3/4" = 28-7/64"$
(695 mm + 19 mm = 714 mm)
Of course, the final door height depends on the gap position of the cabinets that stand to the left and right of the refrigerator cabinet.
6. The height of the refrigerator door panel is:
The total opening of the cabinet (i.e. 70-25/64" (1788 mm)) plus the thickness of the top as well as the floor board (usually 3/4" (19 mm)) minus the height of the freezer door panel (xxx" (xxx mm)) and subtract the width of the gap (approximately 1/8" (3 mm)):
 $70-25/64" + 3/4" + 3/4" - xxx" - 1/8" = 71-49/64" - xxx"$
(1788 mm + 19 mm + 19 mm - xxx mm - 3 mm = 1823mm – xxx mm)

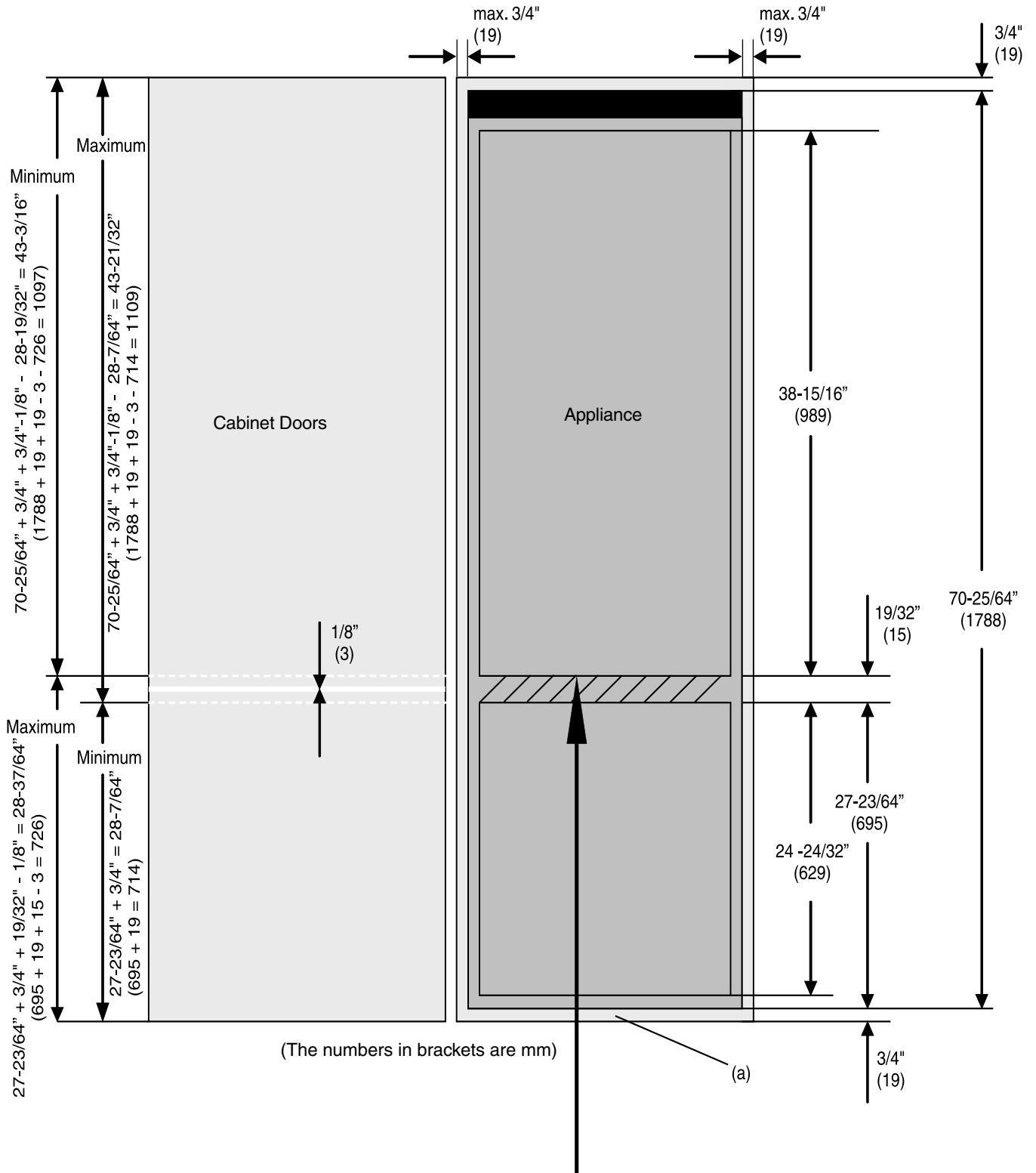

The gap between refrigerator and freezer door must lie within the crosshatched area.

LIEBHERR

Design Guide 2008