

Kräus[®]

INSTALLATION GUIDE

Crespo™ Single Lever Flex Commercial Style Kitchen Faucet

KPF-2730

Congratulations on the purchase of your new Kraus plumbing fixture!

Please keep the box and packaging materials until your product is completely installed. If you have any questions, require technical assistance, or have any problems with your product:



DO NOT RETURN TO STORE

**Please contact our Customer Service Team
1-800-775-0703 / customerservice@kraususa.com**

Have the model number available, and retain a copy of your receipt with purchase date for reference.

If for any reason this product does not meet your expectations, please be sure to repack this product in the original box and packaging material to avoid damage during transit.

Prior to Installation:

- Make sure you have all necessary parts by checking the diagram and parts list. If any part is missing or damaged, please contact Kraus Customer Service at 800-775-0703 for a replacement
- Turn off the hot and cold water supply at the angle stops and turn on the old faucet to release any built up pressure. Remove existing faucet. Clean sink or countertop to remove any debris, plumber's putty, or silicone
- Place bucket under angle stops. Turn on to flush any debris prior to installing new plumbing. Shut off angle stops
- Pre-drilled hole size requirement: 1-3/8" (min) – 1-1/2" (max)
- Max countertop thickness without deck plate: 1-1/2"
- Max countertop thickness with deck plate: 1"
- 1, 2, or 3 hole installation

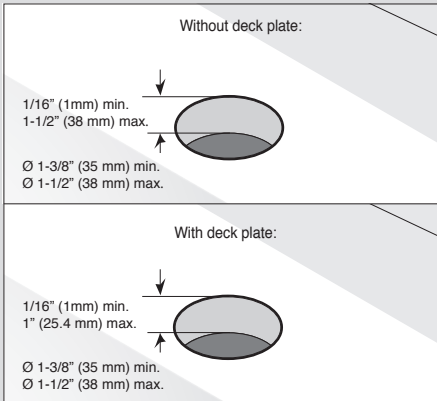

Tools you will need:



Adjustable Wrench

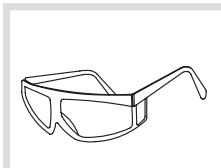

Safety Goggles

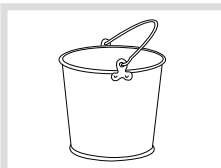

Bucket

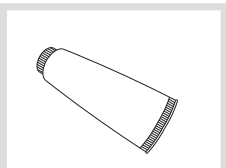

Silicone Sealant

Diagram and Parts List

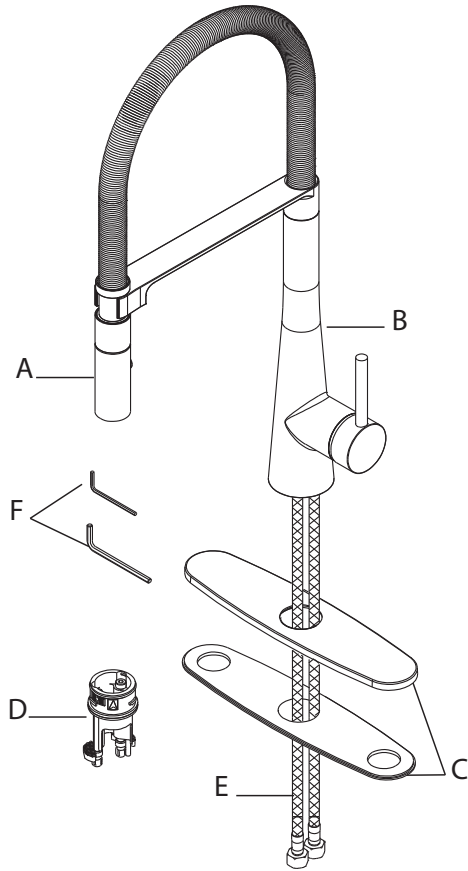

A. Spray Head

B. Faucet Body

C. Deck & Putty Plate

D. Base

E. Hot & Cold Waterlines

F. Hex Wrench Set

F1. 2.5mm

F2. 4mm

Faucet Dimensions

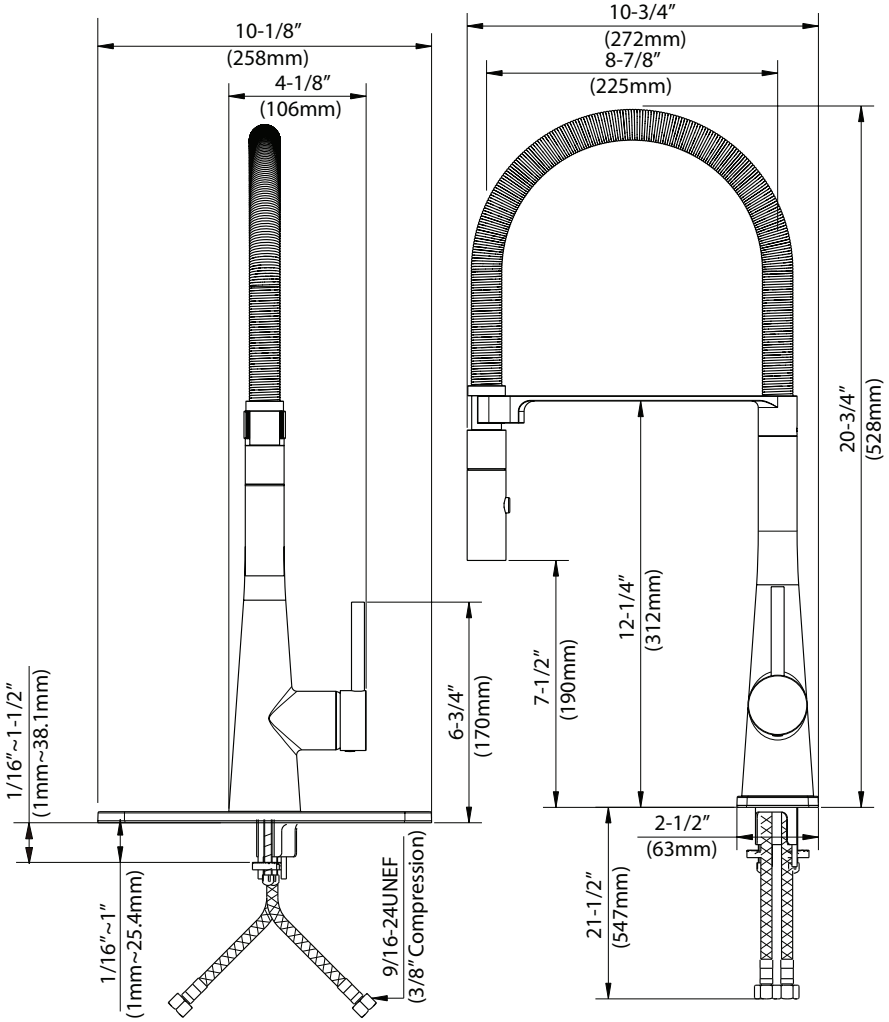

Step 1A: Install base without deck & putty plate

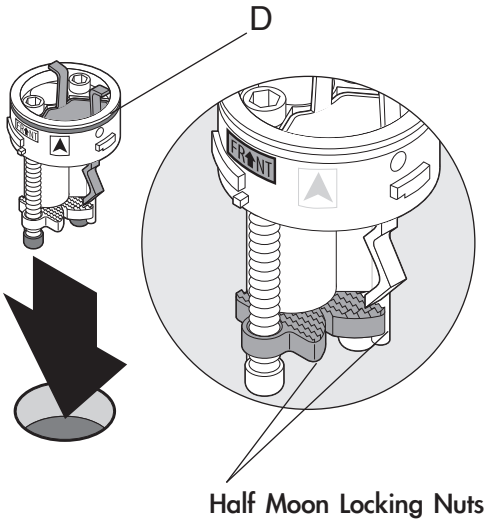

Insert base (D) into sink or countertop with “FR↑NT” facing forward. Tighten screws on base (D) with 4mm hex wrench (F) until base is secure on sink or countertop

Installer Tip: Rotate the two half-moon shaped locking nuts inward before inserting base (D) into sink or countertop

Step 1B: Install base with deck & putty plate

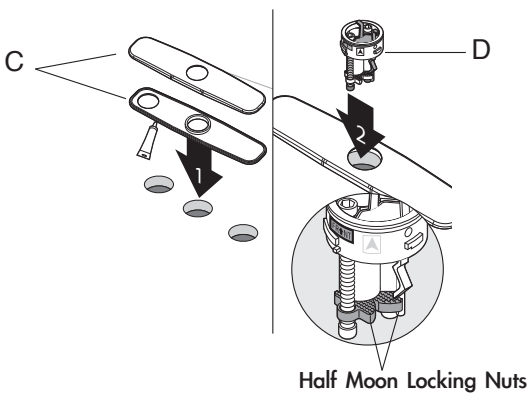

Place a bead of clear silicone sealant (not included) around the edge of the putty plate (C). Secure deck & putty plate (C) on sink or countertop. Insert base (D) into hole of deck & putty plate (C) with “FR↑NT” facing forward. Tighten screws on base (D) with 4mm hex wrench (F) until base is secure on deck & putty plate (C)

Installer Tip: Rotate the two half-moon shaped locking nuts inward before inserting base (D) into deck plate (C)

Step 2: Install faucet

Insert hot & cold waterlines (E), one by one, in large hole of base

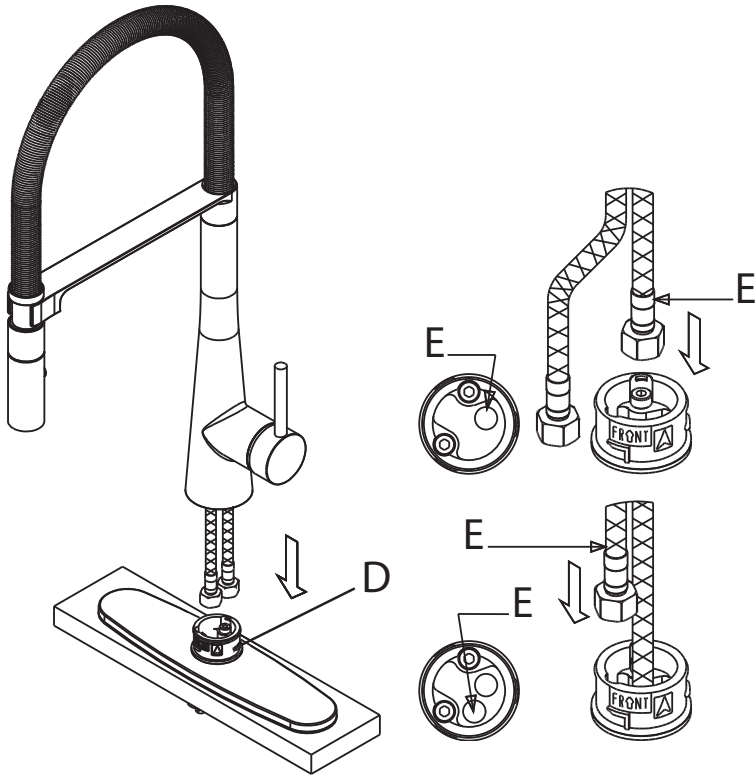

Step 3: Secure faucet

Align arrow on faucet body (B) with arrow on base (D). Attach faucet body (B) to base (D) and turn counter-clockwise. Secure faucet body (B) by tightening the set screw with 2.5mm hex wrench (J)

Installer Tip: Please loosen set screw from faucet body (B) prior to securing to base (D)

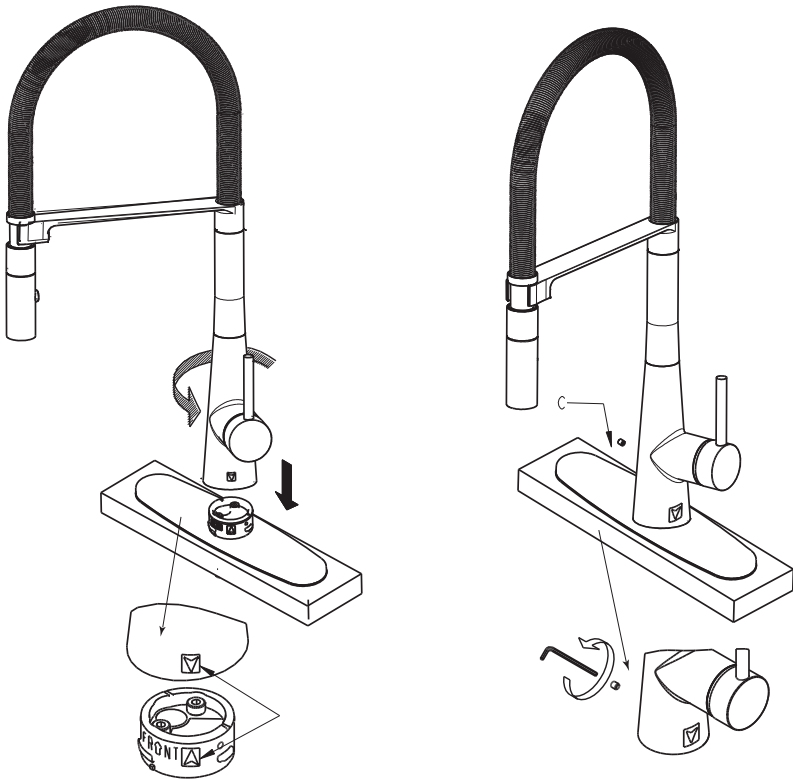

Note: "▲" on base should be in alignment with "▼" on faucet body. Rotate faucet counterclockwise to secure on base.

Step 4: Connect waterlines to main valve

Thread hot & cold waterlines (E) onto angle stops. Tighten with adjustable wrench until snug. Turn on the angle stops and check for leaks (DO NOT TURN FAUCET ON)

Installer Tip: Use two wrenches when securing waterlines to angle stops to prevent kinking, as shown in picture

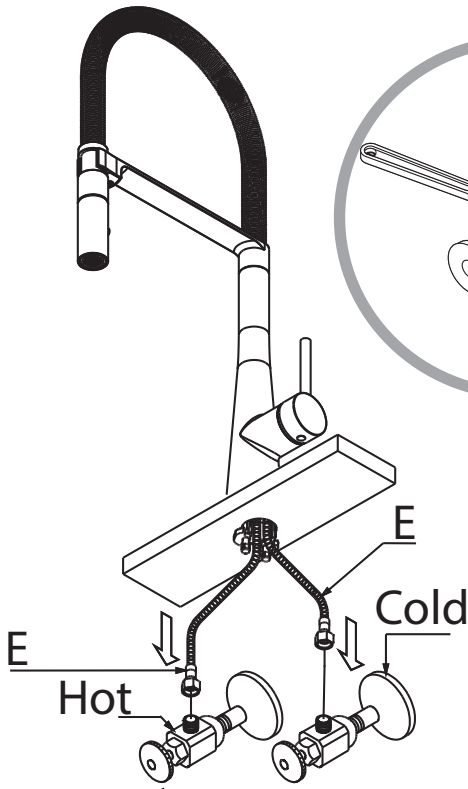

Step 5: Connect quick connect

Remove spray head (A). Hold tip of spray hose. Turn faucet on for 1 minute to flush any debris. Reconnect spray head (A)

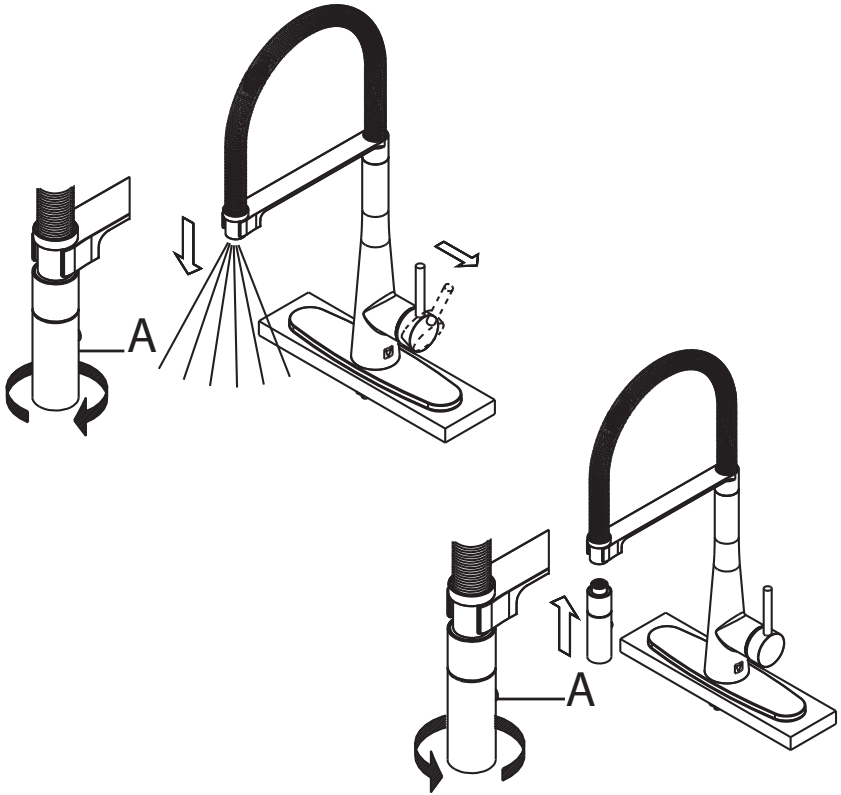

Replacement Part List

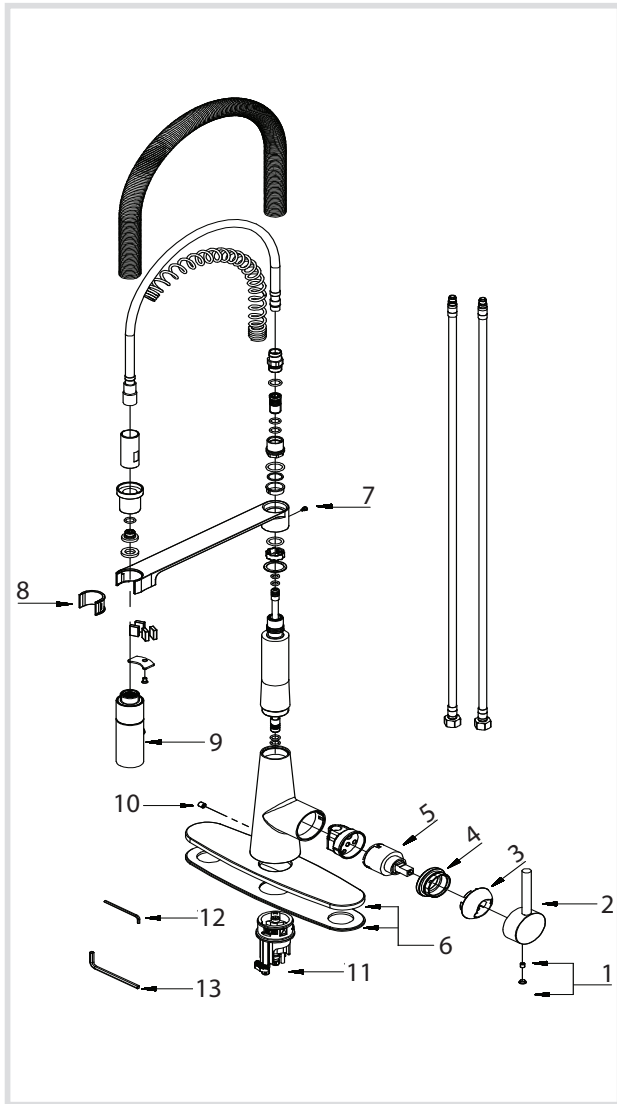

1. A Index Button
B Set Screw
2. Metal Handle
3. Cartridge Cover
4. Locking Nut
5. Cartridge
6. Cover & Putty Plate
7. Set Screw
8. Clip
9. Spray Head
10. Set Screw
11. Base
12. Hex Wrench 2.5mm
13. Hex Wrench 4mm

Trouble - Shooting

If you have followed the instructions carefully and your faucet still does not work properly, take the following corrective steps:

PROBLEM	CAUSE	ACTION
Water will not shut off completely	Cartridge(5) may need to be adjusted or replaced	Remove index button (1A). Loosen set screw (1B) with 2.5mm hex wrench (12). Remove metal handle (2). Remove cartridge cover (3) by hand only. Remove locking nut (4) with an adjustable wrench. Remove ceramic disc cartridge (5). Check for cracks
Leaking from between spray head and hose	Washer may be missing or not seated correctly in hose	Make sure washer is present and seated correctly in hose

Care & Maintenance

*To keep the product clean & shining, follow the steps below:

1. Rinse with clean water & dry with a soft cloth
2. Do not clean with soaps, acid, polish, abrasives, or harsh cleaners
3. Do not use cloth with a coarse surface
4. Unscrew the aerator and clean when necessary

*This installation manual is subject to change without further notice.

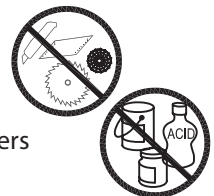

Codes / Standards Applicable:



NSF/ANSI Standard 61 certified by IAPMO
NSF/ANSI Standard 372 certified by IAPMO



Meets ASME A112.18.1M/A112.18.1
1.75gpm 6.6L/min maximum

FAUCET WARRANTY

Kraus products are manufactured and tested to the highest quality standards by Kraus USA Inc. ("Kraus"). Kraus extends this warranty to the original purchaser for personal household use of the "Faucet" in its original location. The warranty is non-transferable.

Kraus warrants the structure and finish of the product to be free from defects in material and workmanship under normal usage for the lifetime of the product. The warranty commences from the initial date of purchase by the owner or trade professional, from an authorized Kraus dealer, through the lifetime of the original owner or end-user.

Kraus warrants the mechanical component (**sprayhead assembly**) of the product to be free from defects in material and workmanship under normal usage for a period of one (1) year. The warranty commences from the initial date of purchase by the owner or trade professional, from an authorized Kraus dealer, through the one (1) year term of the original owner or end-user.

Kraus warrants the mechanical component (**cartridge**) of the product to be free from defects in material and workmanship under normal usage for a period of five (5) years. The warranty commences from the initial date of purchase by the owner or trade professional, from an authorized Kraus dealer, through the five (5) year term of the original owner or end-user.

Any product reported to the authorized dealer or to Kraus as being defective within the warranty period will be repaired or replaced with a product of equal value at the option of Kraus. This warranty extends to the original owner or end-user, and is not transferable to a subsequent owner.

RESTRICTIONS

This warranty does not cover antediluvian, discontinued, or display products, whether such items are purchased at discount outlets, unauthorized dealers, and/or sold on clearance.

This warranty does not cover instances of negligence, misuse, abuse, improper installation, carelessness, accident, hard water or mineral deposits, exposure to corrosive materials, misapplication, damages caused by improper maintenance, alteration of the product, or failure to follow care or installation instructions enclosed with your product. Avoid using abrasive cleaners such as powders, bleach, ammonia, alcohol, or chlorine. Avoid using abrasive pads, steel wool, or wire brushes, as these will damage and wear down the finish.

This warranty does not apply to Products that have not been installed or operated in accordance with instructions supplied by Kraus and all applicable rules, regulations, and legislation pertaining to such installations.

This warranty does not apply unless the Kraus product is installed by a fully insured and licensed trade professional. Kraus insists that such professionals have experience in the installation of bathroom and kitchen manufactured goods.

This warranty does not cover labor charges or costs of removal and reinstallation of said product. This warranty does not allow recovery of incidental or consequential damages, such as loss of use, delay, property damage, or other consequential damages, and Kraus accepts no liability for such damages.

This warranty does not cover Marine or Outdoor Installation.

Except as otherwise provided above, Kraus makes no warranties, expressed or implied, including warranties of

merchantability and fitness for a particular purpose, or compliance with any code.

Shipping charges will be covered for the first (1) year of the warranted replacement part or product (HI, AK, and Puerto Rico shipping charges may apply). International shipping fees are not included.

COMMERCIAL WARRANTY

Kraus extends the above warranty for a period of one (1) year to purchasers of products for industrial, commercial, and business use.

All incidental or consequential damages are specifically excluded. No additional warranties, express or implied, are given, including but not limited to any implied warranty of merchantability or fitness for a particular purpose.

Some states do not allow the exclusion or limitation of incidental or consequential damages or limitations on how long an implied warranty lasts, so the above limitations or exclusions may not apply to you.

This warranty gives you specific legal rights, and you may also have other rights which vary from state to state.

If you are a homeowner please contact a Kraus Customer Service Representative at:

Kraus USA, Inc.
12 Harbor Park Drive
Port Washington, NY 11050
Toll-free 800-775-0703
Customerservice@kraususa.com

If you are a plumbing contractor or trade professional please contact a Kraus Pro Representative at:

Kraus USA, Inc.
12 Harbor Park Drive
Port Washington, NY 11050
516-801-8955
Proservice@kraususa.com

If you are an Authorized Partner please contact a Partner Support Representative at:

Kraus USA, Inc.
12 Harbor Park Drive
Port Washington, NY 11050
516-801-8954
Partnersupport@kraususa.com

In requesting warranty service, please be ready to provide:

1. Proof of purchase.
2. A description of the problem.

Download the Kraus Care & Maintenance Guide at:

<http://www.kraususa.com/maintenance>

IMPORTANT

Register Your Kraus Product

Activate Your Warranty

Access Premium Customer Support

Get Product Information

REGISTER TODAY

<http://www.kraususa.com/registration>



Kräus[®]
www.kraususa.com