



USER MANUAL

ICE NUGGET MAKER

KoolMore Built-in Residential Pearl Ice Nugget maker

Model: KM-BIM66-NSS

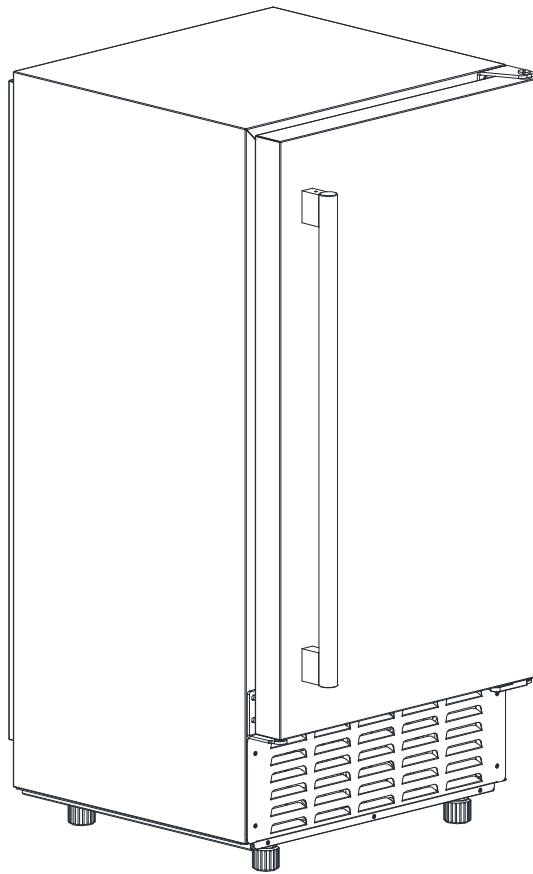

Before using, please read the operating instructions carefully to ensure proper application and achieve satisfactory results.

For any service-related issues, please contact us:



718-576-6342



support@koolmore.com

***Stay informed with the latest information
for your KoolMore Appliance.***

**If you need any assistance or have questions, our customer
support team is here to help.**

SAFETY

- When using electrical appliances, basic safety precautions should be followed to reduce the risk of fire, electric shock, and injury to persons or property. Read all instructions before using any appliance.
- Use this appliance only for its intended purpose as described in this owner's manual. This ice-maker must be properly installed in accordance with the installation instructions before it is used.
- This unit must be positioned so that the plug is accessible. Do not run cord over carpeting or other heat insulators. Do not cover the cord. Keep cord away from traffic areas, and do not submerge in water. No other appliance should be plugged into the same outlet, and be sure that the plug is fully inserted into the receptacle.
- We do not recommend the use of extension cords as it may overheat and cause a risk of fire. If you must use an extension cord, use No.18AWG minimum size and rated no less than 1875 watts.
- If the supply cord is damaged, it must be replaced by the manufacturer or its service agent or a similarly qualified person in order to avoid a hazard.
- Remove power plug or disconnect from the mains before cleaning or servicing the appliance. NOTE: If for any reason this product requires readjustment, reprogramming and manual restart then technician or a similarly qualified person is to do service, to avoid being electrocuted or to let technical happen potentially the service.
- Never unplug you unit by pulling on the power cord. Always grasp the plug firmly and pull straight out from the outlet.
- Do not use your unit outdoors. Keep the unit away from direct sunlight and make sure that.
- there is at least 6 inches of space between the back of your unit and wall and keep the front free. Keep ventilation opening in the appliance enclosure or in the built-in structure, clear of obstruction.
- Do not tip over the unit which will cause abnormal noisy and make the ice-cube size abnormal. And seriously, it may cause water leakage from the unit.
- If the unit is brought in from outside in the winter season, give it a few hours to warm up to room temperature before plugging it in.
- Do not use other liquid to make the ice-cube other than water.
- Do not clean your ice maker with flammable fluids. The fumes can create a fire hazard or explosion.

WARNING: This appliance must be earthed. Use the proper power source according to the nameplate.

WARNING: Keep ventilation openings, in the appliance enclosure or in the built-in structure, clear of obstruction.

WARNING: Do not damage the refrigerant circuit.

WARNING: This appliance is not intended for use by persons (including children) with reduced physical, sensory

or mental capabilities, or lack of experience and knowledge, unless they have been given supervision or instruction concerning use of the appliance by a person responsible for their safety.

WARNING: Children should be supervised to ensure that they do not play with the appliance.

WARNING: This appliance must be earthed. And use the 110-120V/60Hz earthed power supply.

WARNING: Do not store explosive substances such as aerosol cans with a flammable propellant in this appliance.

DANGER – Risk Of Fire or Explosion. Flammable Refrigerant Used. Do Not Use Mechanical Devices To Defrost Ice Maker. Do Not Puncture Refrigerant Tubing.

CAUTION – Risk Of Fire Or Explosion. Flammable Refrigerant Used. Consult Repair Manual/Owner’s Guide Before Attempting To Install or Service This Product. All Safety Precautions Must be Followed.

CAUTION – Risk Of Fire Or Explosion. Dispose Of Property In Accordance With Federal Or Local Regulations. Flammable Refrigerant Used.

CAUTION – Risk Of Fire Or Explosion Due To Puncture Of Refrigerant Tubing; Follow Handling Instructions Carefully. Flammable Refrigerant Used.

The ice maker should be installed in accordance with the safety standard for Refrigeration Systems, ASHRAE15. The ice maker shall not be installed in corridors or hallways of public buildings.

If the unit is with problem need to be maintained, that replacing with like components and that servicing shall be done by factory authorized service personnel, so as to minimize the risk of possible ignition due to incorrect parts or improper service.

WARNING: Keep ventilation openings, in the appliance enclosure or in the built-in structure, clear of obstruction.

WARNING: This appliance is intended to be used in household and similar applications such as
E.g., staff kitchen areas in shops, offices and other working environments;
E.g., farmhouses and by clients in hotels, motels and other residential type environments;
E.g., bed and breakfast type environments;
E.g., catering and similar non-retail applications.

To avoid a hazard due to instability of the appliance, it must be placed at an even or flat surface.

The wires in this mains lead are colored in accordance with the following code:

Green or Green with a strip yellow Grounding
Blue or White Neutral
Brown or Black..... Live

INSTALLATION

UNPACKING YOUR ICE MAKER

1. Remove the exterior and interior packaging. Check if all the accessories are inside or not including the instruction manual, ice scoop, white water inlet pipe, the water draining pipe, the quick connector (connecting a 1/4-inch connector with a 1/2-inch one), etc. If any parts are missing, please contact our customer service.
2. Remove the tapes for fixing the door and inner cabinet, ice scoop, etc. Roughly clean the inner cabinet & ice scoop with wet cloth.

Put the ice maker on a level & flat floor, without direct sunlight and other sources of heat (i.e.: stove, furnace, radiator). Make sure that there is at least 50cm gap between the air outlet and the obstacles, and at least 5 cm between the wall.

Allow 4 hours for the refrigerant fluid to settle before plugging the ice maker in if the unit maybe fall upside down during shipping or transportation.

The appliance must be positioned so that the plug is accessible.

WARNING: connect to the potable water supplying only. Only use drinking water.

INSTALL THE HANDLE

1. Open the attachment and locate the two screws, Then screw in the screw hole.
2. Find the door handle and align it with the screw hole.
3. Find the hexagonal screw and tighten it in the specified position.

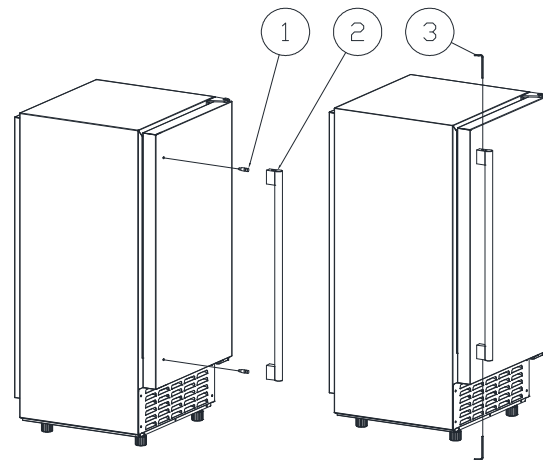

INSTALLATION LOCATION REQUIREMENT

This unit is not for outdoor use. Keep the proper room temperature and inlet water temperature according to the above specification table. Otherwise, it will affect the ice making performance.

This unit should not be located near any heat resource.

The unit should be located on a firm & level foundation at normal counter top height.

There must be at least a 2-inch clearance at rear side for connection and a 10-inch clearance in the front to open the door and keep good air circulation.

Do not put anything on the top of the ice maker.

To ensure proper ventilation for your ice maker, the front of the unit must be completely unobstructed (at least a 16-inch free space). Allow about 0.2 inches clearance at rear, and 0.2 inches at top for proper air circulation.

When installing the ice maker under a counter, follow the recommended spacing dimensions shown above. Place electrical and water supplies and drain fixtures in the recommended locations as shown. Choose a well-ventilated area with temperatures above 50 °F and below 90 °F. This unit **MUST** be installed in an area protected from the elements, such as wind, rain, water spray, or drips.

The ice maker requires a continuous water supply with 1-8 bar pressure as required in above specification table. The temperature of the water feeding into the ice maker should be between 41°F and 77°F for proper operation.

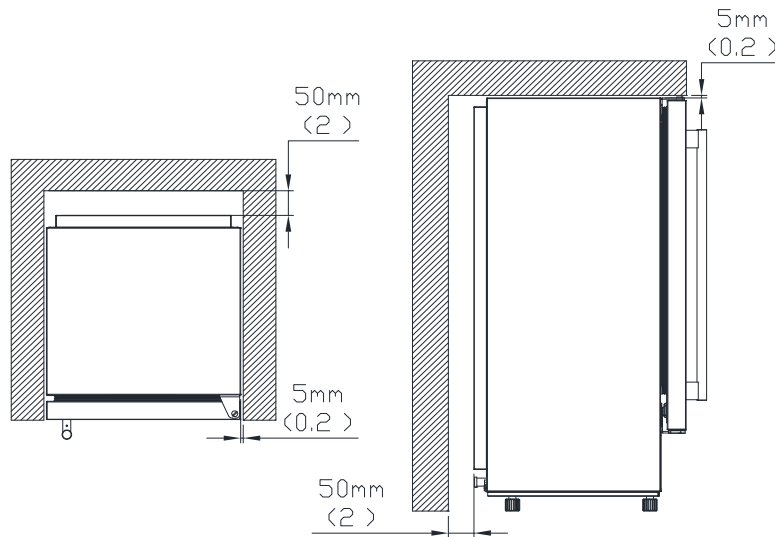

ELECTRICAL REQUIREMENT & CONNECTIONS

WARNING: THIS UNIT MUST BE EARTHED.

- Electrical Shock Hazard plug into a grounding wall outlet.
- Never remove the ground prong.
- Use separate power supply or receptacle. Never use an adapter.
- Never use an extension cord.
- Failure to follow these instructions can result in death, fire, or electrical shock.

Before you move your ice maker into its final location, it is important to make sure you have the proper electrical connection.

It is recommended that a separate circuit, serving only your ice maker, be provided. Use receptacles that cannot be turned off by a switch or pull chain. If the supply cord or plug to be replaced, it should be done by a qualified service engineer.

This appliance requires a standard 110-120Volt, 60Hz electrical outlet with good grounding means.

Recommended grounding method

For your personal safety, this appliance must be properly grounded. This appliance is equipped with a power supply cord having a grounding plug. To minimize possible shock hazard, the cord must be plugged into a mating grounding-type wall receptacle, grounded in accordance with the National Electrical Code and local codes and ordinances. If a mating wall receptacle is not available, it is the personal responsibility of the customer to have a properly grounding wall receptacle installed by a qualified electrician.

WATER CONNECTION FOR YOUR ICE MAKER

Important: Be sure to use the new hose-sets supplied with the appliance to connect to water mains and that old hose-sets should not be reused.

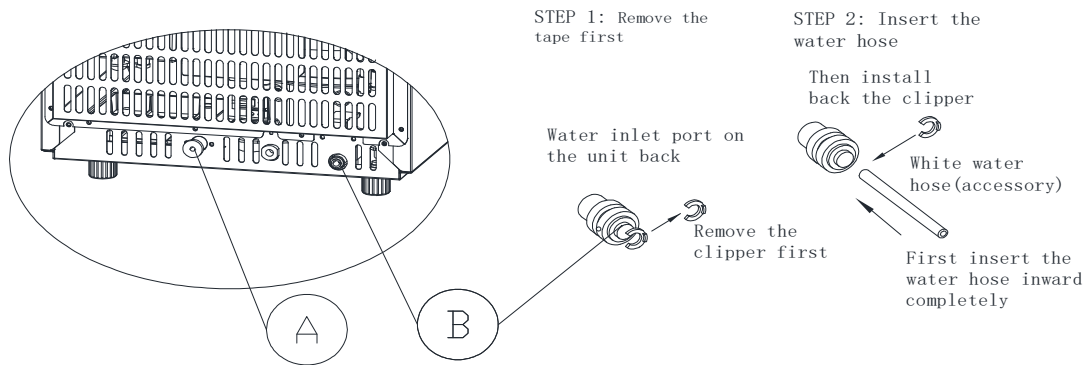

Connect the water supplying hose to the unit

Step 1: First remove the tape on the water inlet port for water supply (indicated in the following illustration "B") located at unit back, then use your other hand's finger to press the out circle.

Step 2: Insert the one end of the white water hose into the water inlet port, and push inward completely, and install back the clipper, then water hose connection is completed.

Connecting the water drain pipe

Pull out the water drainage cap with black color (indicated "A" in Fig.6), then connect the white drainage pipe included in accessory, again connect the other end of this drainage to the main water drainage pipeline.

Connect the water hose to the water faucet of the water main supply system

First, install the supplied water quick-connector to the water faucet by screw thread; Second, remove the clipper from the water quick-connector, insert the another end of the water hose into this quick-connector port completely, then install back the clipper, also this step is completed. Note: The water faucet should be supplied by the customer himself.

Important: The water pressure of main water supply system must be 0.04-0.6 MPa at least.

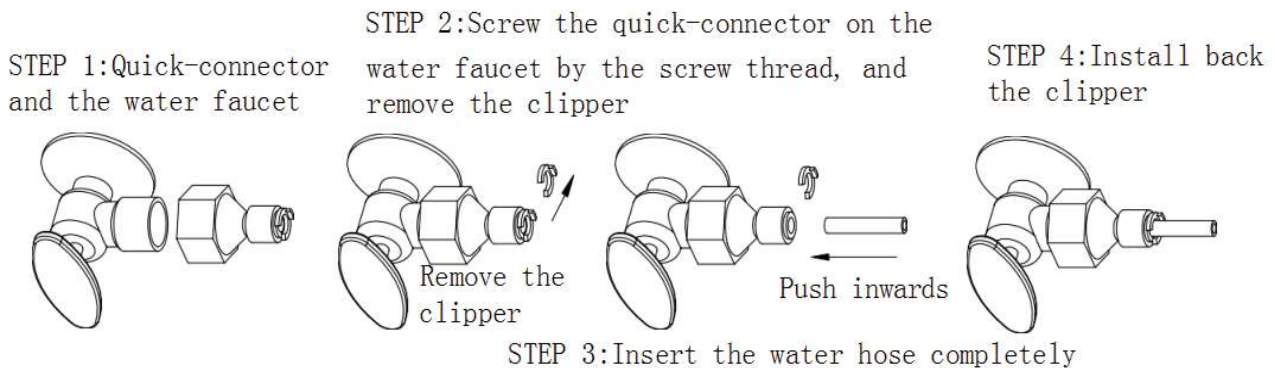

Normal Sounds

Your new ice maker may make sounds that are not familiar to you. Most of the new sounds are normal. Hard surfaces like the floor, walls and cabinets can make the sounds seem louder than they actually are. The following describes the kinds of sounds that might be new to you and what may be making them.

- You will hear a swooshing sound when the water valve opens to fill the water tank for each cycle.
- Rattling noises may come from the flow of the refrigerant or the water line. Items stored on top of the ice maker can also make noises.
- The high-efficiency compressor may make a pulsating or high-pitched sound.
- Water running from the water tank to the evaporator plate may make a splashing sound.
- Water running from the evaporator to the water tank may make a splashing sound.
- As each cycle ends, you may hear a gurgling sound due to the refrigerant flowing in your ice maker.
- You may hear air being forced over the condenser by the condenser fan. During the harvest cycle, you may hear the sound of ice cubes falling into the ice storage bin.
- When you first start the ice maker, you may hear water running continuously. The ice maker is programmed to run a rinse cycle before it begins to make ice.

Preparing the Ice Maker for Long Storage

If the ice maker will not be used for a long time, or is to be moved to another place, it will be necessary to drain out all of the water in the system.

1. Allow all of the ice cubes have been ejected from the evaporator of ice maker.
2. Turn off the unit, and unplug the power cord.
3. Shut off the water supply at the main water supply.
4. Disconnect the water supply hose from the water inlet valve.
5. Pull out the Water drain pipe of the water tank indicating "H" in above illustration to drain out the water in the water tank. When all of the water has been drained out, to reinstall back the water drain pipe of the water tank.
6. Then drain out all of the water from the water drain port located at unit back indicating "7" in above illustration.
7. Disconnect the water drain pipe to the main drain pipeline or floor drain, plug on the drain cap again.
8. Drop the door open to allow for circulation and prevent mold and mildew.
9. Leave water supply hose and power cord disconnected until ready to reuse.
10. Dry the interior & wipe the outside of the unit.
11. Put a plastic bag on the unit to resist out dust & dirty.

OPERATION

OPERATION YOUR UNIT

- Operation button and display area diagram

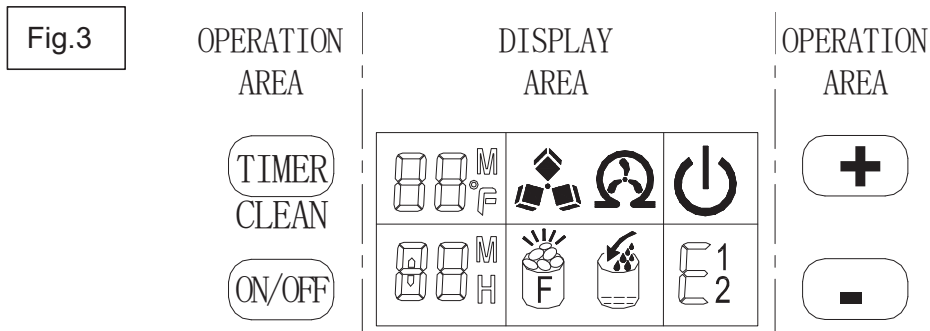







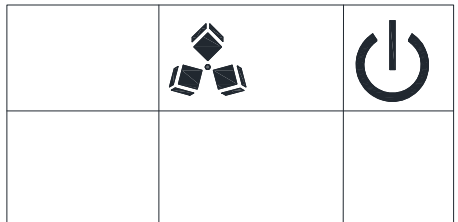



















- OPERATION OF ICE MAKING PROCESS

TIMER CLEAN	Quickly press this button once, to enter the Timer setting program; And press this button for more than 5 seconds, to enter the Cleaning program.
ON/OFF	When the unit is off, press this button to turn on the unit; And during the Self-cleaning program, or normal ice-making state, press this button to turn off the unit at once; And also if the unit is set with the Timer, press this button to cancel the Timer setting.
LCD display window	Function display panel
“+” “-”	Timer adjustment

- Symbol Description

1	Environmental temperature display. Press “+” button longer than 5s, Fahrenheit (°F) or Celsius (°C) will automatically switch.	
2	Making ice and deice symbol display <ol style="list-style-type: none"> 1. The machine is making ice when the symbol rotated 2. The machine is ice making abnormal when the symbol flash. 	

3	<p>Automatic self-cleaning symbol display.</p> <ol style="list-style-type: none"> 1. Press "TIMER CLEAN" button on control panel for more than 5 seconds, to enter the self-Cleaning program. 2. The default cleaning time is 15 minutes. 3. Press the "ON/OFF" button on control panel to cancel the self-cleaning program by force. 	<table border="1"> <tr> <td data-bbox="1032 138 1187 275"></td> <td data-bbox="1187 138 1373 275"></td> <td data-bbox="1373 138 1498 275"></td> </tr> <tr> <td data-bbox="1032 275 1187 405"></td> <td data-bbox="1187 275 1373 405"></td> <td data-bbox="1373 275 1498 405"></td> </tr> </table>						
								
4	On/off symbol display	<table border="1"> <tr> <td data-bbox="1032 405 1187 541"></td> <td data-bbox="1187 405 1373 541"></td> <td data-bbox="1373 405 1498 541"></td> </tr> <tr> <td data-bbox="1032 541 1187 669"></td> <td data-bbox="1187 541 1373 669"></td> <td data-bbox="1373 541 1498 669"></td> </tr> </table>						
								
5	<p>Error code display</p> <p>E1 No water ingress for a long time E2 means the environmental temperature sensor is damaged. E means drain pump not work.</p>	<table border="1"> <tr> <td data-bbox="1032 669 1187 793"></td> <td data-bbox="1187 669 1373 793"></td> <td data-bbox="1373 669 1498 793"></td> </tr> <tr> <td data-bbox="1032 793 1187 915"></td> <td data-bbox="1187 793 1373 915"></td> <td data-bbox="1373 793 1498 915">E¹₂</td> </tr> </table>						E ¹ ₂
								
		E ¹ ₂						
6	<p>Water flow in and water shortage display</p> <ol style="list-style-type: none"> 1. The arrow flashing indicates that the machine is adding water. 2. The whole symbol is bright to indicate that the machine is short of water. 	<table border="1"> <tr> <td data-bbox="1032 915 1187 1039"></td> <td data-bbox="1187 915 1373 1039"></td> <td data-bbox="1373 915 1498 1039"></td> </tr> <tr> <td data-bbox="1032 1039 1187 1180"></td> <td data-bbox="1187 1039 1373 1180"></td> <td data-bbox="1373 1039 1498 1180"></td> </tr> </table>						
								
								
7	<p>Ice full alarm</p> <ol style="list-style-type: none"> 1. The machine will making ice again when you take out the ice. 2. When this symbol appears and cannot be eliminated, long press the power button to force the ice for 80 minutes. 	<table border="1"> <tr> <td data-bbox="1032 1180 1187 1316"></td> <td data-bbox="1187 1180 1373 1316"></td> <td data-bbox="1373 1180 1498 1316"></td> </tr> <tr> <td data-bbox="1032 1316 1187 1451"></td> <td data-bbox="1187 1316 1373 1451"></td> <td data-bbox="1373 1316 1498 1451"></td> </tr> </table>						
								
								
8	<p>Setting display timed switch machine: 1-24 hours</p> <ol style="list-style-type: none"> 1. When the machine is running, set to shut down after 1 hour. 2. When the machine is on standby, set it to turn on after 1 hour 	<table border="1"> <tr> <td data-bbox="1032 1451 1187 1575"></td> <td data-bbox="1187 1451 1373 1575"></td> <td data-bbox="1373 1451 1498 1575"></td> </tr> <tr> <td data-bbox="1032 1575 1187 1694">0 1H</td> <td data-bbox="1187 1575 1373 1694"></td> <td data-bbox="1373 1575 1498 1694"></td> </tr> </table>				0 1H		
								
0 1H								

MAINTENANCE

CLEANING TIPS

WARNING:

Before carrying out any cleaning or maintenance operations, unplug the ice maker from the main power supply electricity. (EXCEPTION: Ice maker self-cleaning program).

Do not use any alcohol or fume for cleaning / sanitize of the ice maker. It may cause cracks on the plastic parts.

Ask a trained service person to check and clean the condenser at least once a year, in order to let the unit work properly.

This appliance must be cleaned by use of a water jet.

CAUTION

If the ice maker has been left unused for a long time, before the next use it must be thoroughly cleaned. Follow carefully any instructions provided for cleaning or use of sanitizing solution. Do not leave any solution inside the ice maker after cleaning.

Periodic cleaning and proper maintenance will ensure efficiency, top performance, hygienic, and long life. The maintenance intervals listed are based on normal conditions. You may want to shorten the intervals if you have pets, or the unit is used outdoors, or there are other special considerations.

What shouldn't be done

Never keep anything in the ice storage bin that is not ice: objects like wine and beer bottles are not only unsanitary, but also it's labels may slip off and obstruct the drain pipe.

Exterior Cleaning

The door and cabinet may be cleaned with a mild detergent and warm water solution such as 28g of dish washing liquid mixed with 7.5L of warm water. Do not use solvent-based or abrasive cleaners. Use a soft sponge and rinse with clean water. Wipe with a soft clean towel to prevent water spotting.

Stainless steel models can discolor when exposed to chlorine gas and should be cleaned. Clean stainless steel models with a mild detergent and warm water solution and a damp cloth. Never use abrasive cleaning agents.

NOTICE: Stainless steel models exposed to chlorine gas and should be cleaned, such as in areas with spas or swimming pools, may have some discoloration of stainless steel. Discoloration from chlorine gas is normal.

CLEAN THE PROCESS

Before using your ice maker, it is strongly recommended to clean it thoroughly.

1. Use both thumbs to open the transparent window. (Fig.5)
2. Repeatedly clean the water contacting inner parts.

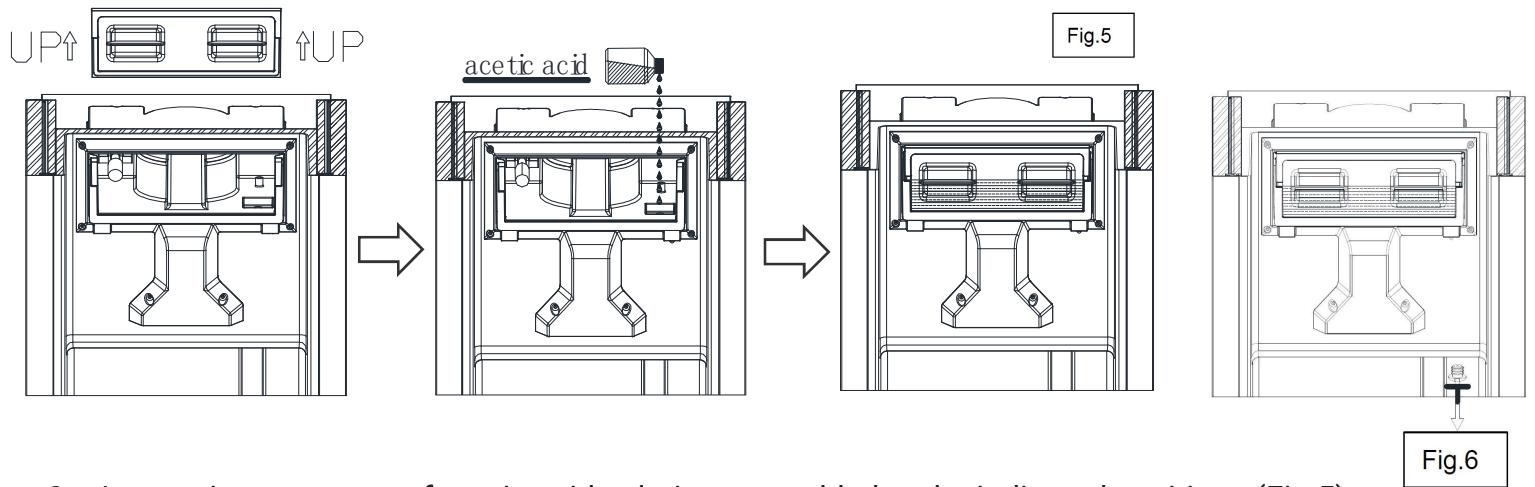

3. Appropriate amounts of acetic acid solution was added at the indicated positions.(Fig.5)
4. Reinstall the transparent windows to prevent water leakage, please ensure proper installation.
5. Press the cleaning button on the operation panel for more than 5 seconds to start the cleaning program, and the cleaning will end after 15 minutes.
6. You can pull the drain plug (Fig.6) to drain the cleaned water in the water tank.
Note:This operation step is mainly to soak the ice-making mechanism to dissolve the stubborn scale
7. Then reinstall the drain plug. (Fig.6)
8. Start the cleaning program again, end in fifteen minutes, then press the power button to start ice making.
9. Ice produced within 15 minutes is not recommended for consumption
10. The outside of the ice maker should be cleaned regularly with a mild detergent solution and warm water.
11. Dry the interior and exterior with a clean soft cloth.

INTERIOR CLEANING FOR ICE STORAGE BIN

The ice storage bin should be sanitized occasionally. Clean the bin before the ice maker is used for the first time and reused after stopping for an extended period of time. It is usually convenient to sanitize the bin after the ice making system has been cleaned, and the storage bin is empty.

1. Disconnect power to the unit.
2. Open the door and with a clean cloth, wipe down the interior with a sanitizing solution made of 28g of household bleach or chlorine and 7.5L of hot water(95°F to 115°F).
3. Rinse thoroughly with clear water. The waste water will be drained out through the drain pipe.
4. Reconnect power to the unit.

NOTICE: The ice scoop should be washed regularly. Wash it just like any other food container.

WARNING

DO NOT use solvent cleaning agents or abrasives on the interior. These cleaners may transmit taste to the ice cubes, or damage or discolor the interior.

CLEANING SUGGESTION

DAILY CLEANING

The ice shovel, door and the water dividing pipe should be cleaned by yourself per each day. At the

end of every day, rinse the ice shovel and wipe the both sides of the door with a clean cloth.

SEMI-MONTHLY CLEANING

The ice shovel, ice bin, water tank, the ice-full detecting plate and the surface of the evaporator are to be cleaned by yourself semi-monthly according to interior cleaning program.

SEMI-ANNUAL CLEANING

All the components & surfaces exposed to water or ice cubes, like ice storage bin, water tank, door, evaporator, water pump, silicone tube, water dividing pipe, etc. should be cleaned by Using

Nu-Calgon Nickle Safe Ice-machine Cleaner per each 6 months. They should be cleaned by the serviceman according to ice making assembly system cleaning program.

TROUBLESHOOTING

Problem	Possible Cause	Solution
☾ ❄️ symbol is lightening on and the arrow flashes.	Lack of Water.	Stop the ice maker, fill water, and press "ICE/CLEAN" button again to restart the unit.
	There is too much ice.	Suggest you obtain the ice-cube. Remove the probable obstacle inside or clean the inside wall of the ice storage
❄️ F" symbol is lightening and letter "F" flashes.	(No ice cube inside.)	Press "ICE/CLEAN" button for 5 seconds, it will work for 80 minutes.
E1	Ambient temperature or water temperature in inner tank is too high.	Please run the ice maker below 90 Fahrenheit degree ambient and pour colder water into tank.
	Refrigerant liquid leakage.	Press the ICE button twice, restart ice making program, if this problem show up again, verify by a qualified technician.
	Cover motor is broken	
	Pipe in the cooling system is blocked.	
Making Ice too slowly	Hot Air outlet has been blocked by something.	Hot Air outlet must be guaranteed to have more than 15 CM of ventilation distance.
	Water temperature in inner tank is too high.	Water temperature requirement between 7°C-32°C.
	Refrigeration system malfunctions.	Verify by a qualified technician.
Water leakage	Drain plug not in place	Put the drain plug in place.
	Pipe Joint in the appliance may Loose	Verify by a qualified technician.
	The seal has reached service life	Verify by a qualified technician.

CIRCUIT DIAGRAM

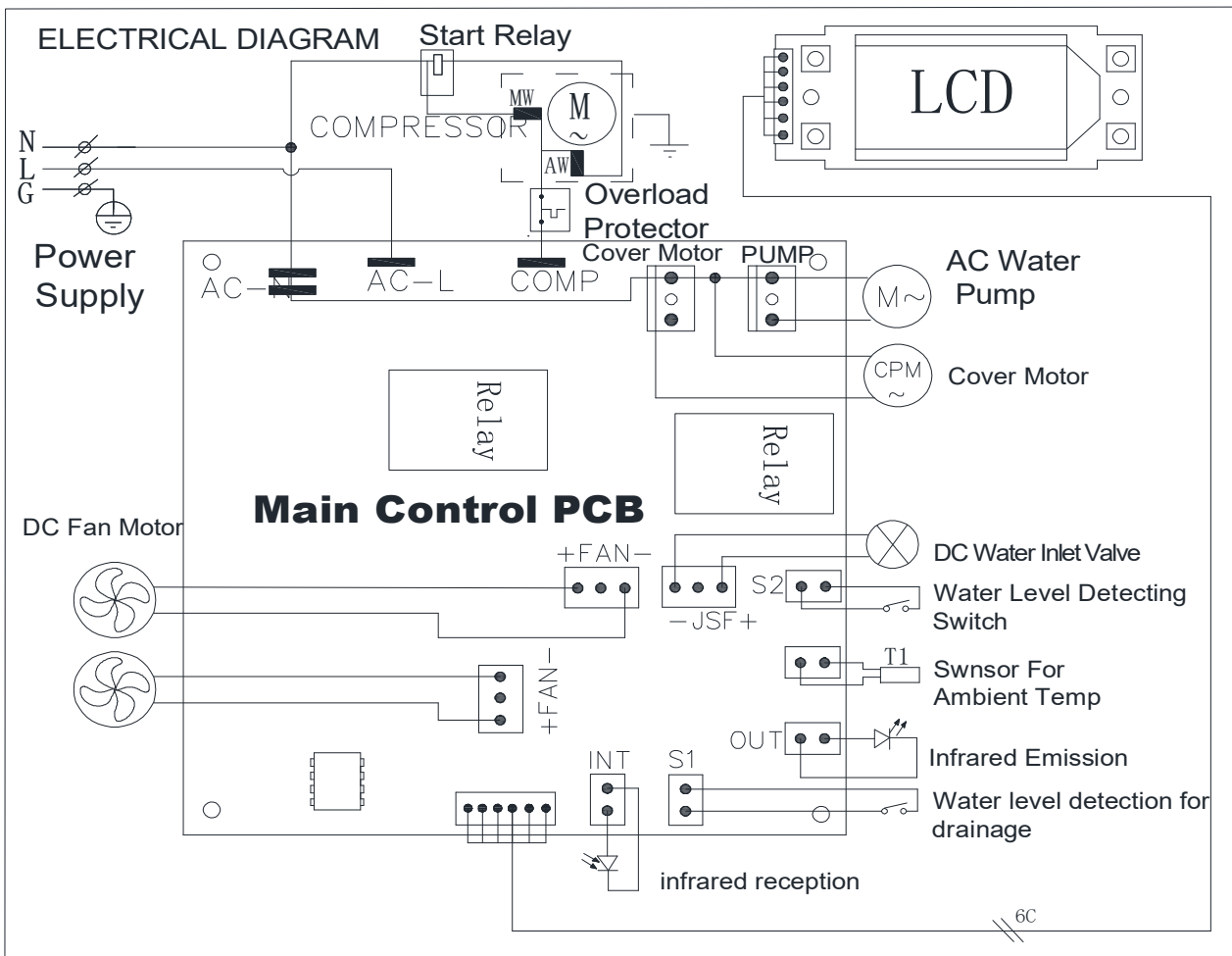

Disposal

When the unit is not to be used again, disposal of this unit's material shall be in accordance with national regulations.



WARRANTY

LIMITED WARRANTY

Koolmore Supply, Inc. extends a limited warranty to the original purchaser, guaranteeing that this Koolmore product is free from manufacturing defects in material or workmanship for one year from the date of purchase.

Should you discover any such defect within the warranty period, Koolmore Supply, Inc., reserves the right to repair or replace the product without charge, or to cover the cost of replacement parts and repair labor needed

to correct defects present at the time of purchase or resulting from regular usage, when the appliance has been

installed, operated, and maintained as per the instructions provided.

At its sole discretion, Koolmore Supply Inc. may decide to replace the product. In such an event, your replacement

appliance will carry the warranty for the remaining term of the original unit's warranty period.

This warranty is valid exclusively to the original purchaser of the product and only applicable within the United

States. The warranty commences from the date of original consumer purchase. Proof of the original purchase

date will be required to obtain service under this warranty.

Under this limited warranty, your sole and exclusive remedy will be product repair, as outlined above. All services must be provided by a Koolmore-designated service company.

To claim warranty or request repair service:

Email support@koolmore.com. Please include your name, address, phone number, warranty repair request,

and a copy of your proof of purchase receipt. Alternatively, visit koolmore.com and use the contact us page. A

Koolmore customer service representative will promptly arrange service for your appliance.

We thank you for choosing Koolmore.

WARRANTY EXCLUSIONS

This limited warranty will not cover:

1. Failure of the product to perform during power failures or interruptions, or due to inadequate electrical service.
2. Damage incurred during transportation or handling.
3. Damage caused by accidents, vermin, lightning, winds, fire, floods, or acts of God.
4. Damage resulting from accidents, alterations, misuse, abuse, improper installation, repair, or maintenance.

This includes using any external device that alters or converts the voltage or frequency of electricity.

5. Unauthorized product modifications, repairs by unauthorized centers, or use of non-approved replacement parts.

6. Abnormal cleaning and maintenance not aligned with the user's manual.

7. Use of incompatible accessories or components.

8. Any costs associated with repairs or replacements under these excluded circumstances shall be the responsibility of the consumer.

