

Miele

Operating and Installation Instructions

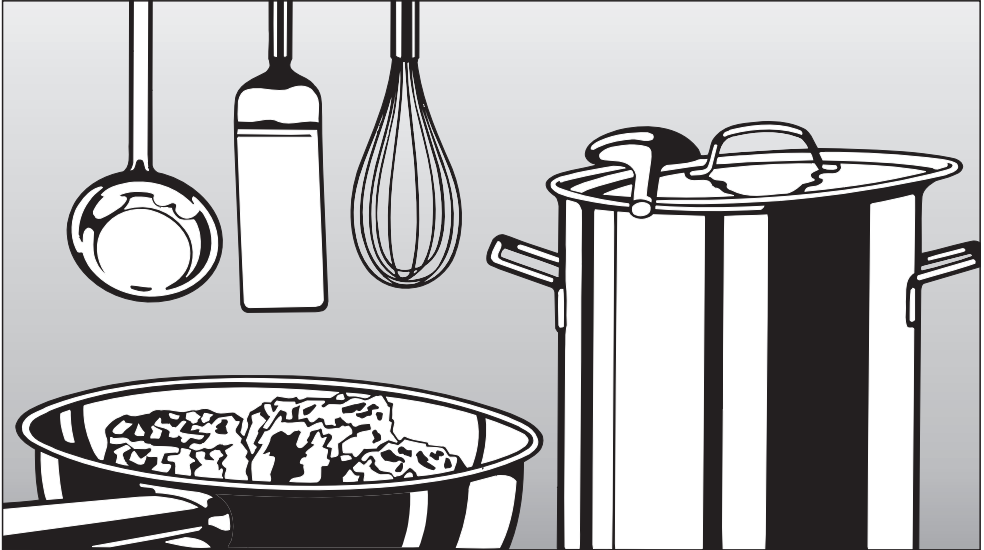

Gas Cooktop

KM 3464 / KM 3465

KM 3474 / KM 3475

KM 3484 / KM 3485



To prevent accidents and
machine damage,
read the Operating Manual
before installation or use.



M.-Nr. 06 818 490

WARNING:

If the information in this manual is not followed exactly, a fire or explosion may result causing property damage, personal injury or death.

- **Do not store or use gasoline or other flammable vapors and liquids in the vicinity of this or any other appliance.**
- **WHAT TO DO IF YOU SMELL GAS**
 - **Do not try to light any appliance.**
 - **Do not touch any electrical switch.**
 - **Do not use any phone in your building.**
 - **Immediately call your gas supplier from a neighbor's phone. Follow the gas supplier's instructions.**
 - **If you cannot reach your gas supplier, call the fire department.**
- **Installation and service must be performed by a qualified installer, service agency or the gas supplier.**
(In Massachusetts a licensed plumber / gas fitter)
- **Note to the installer:**
Please leave this instruction book with the consumer for the local electrical / gas inspector's use.

Contents

IMPORTANT SAFETY INSTRUCTIONS	5
Guide to the cooktop	9
KM 3464 / KM 3465	9
KM 3474 / KM 3475	10
KM 3484 / KM 3485	11
Before using the cooktop	12
Cleaning the cooktop	12
Using the cooktop	13
Fast-Ignition-System	13
Turning on and off / Regulating	13
Pan size	15
Suitable pans	15
Safety feature	16
Using the cooktop during a power failure	16
Cleaning and care	17
Frequently asked questions	19
Technical Service	20
IMPORTANT SAFETY INSTRUCTIONS	22
Appliance dimensions	24
KM 3464 / KM 3465	24
KM 3474 / KM 3475	25
KM 3484 / KM 3485	26
Installation	27
Setting the cooktop into place	28
Securing the cooktop	28
Electrical connection	30
Wiring diagram	31
Gas connection	32
Gas pressure regulator	33
Nominal Rating Table	34
Converting to another type of gas	35
Help protect our environment	36

IMPORTANT SAFETY INSTRUCTIONS

Installation and connection

When using your gas appliance follow basic safety precautions including the following:

- Read all instructions before using for the first time.
- Be certain your appliance is properly installed and grounded by a qualified technician.
- To guarantee the electrical safety of this appliance, continuity must exist between the appliance and an effective grounding system. It is imperative that this basic safety requirement be met. If there is any doubt, have the electrical system of the house checked by a qualified electrician. The manufacturer cannot be held responsible for damages caused by the lack, or inadequacy, of an effective grounding system.
- Install the appliance so that the power cord and gas piping do not come into contact with any portion of the cooktop which may become hot during use.
- Do not connect the appliance to the main electrical supply using an extension cord. Extension cords do not meet the safety requirements of this appliance.

■ Before servicing, turn off the gas valve and disconnect the power supply by either removing the fuse, unplugging the unit or manually “tripping” the circuit breaker.

■ This equipment has not been designed for maritime use or for use in mobile installations such as aircraft or recreational vehicles. However, under certain circumstances it may be possible for installation in these applications. Please contact the nearest Miele Dealer or the Miele Technical Service Department with specific requirements.

■ After connecting the appliance test for leaks according to the installation instructions.

■ If there is any doubt concerning installation contact Miele's Technical Service Department.

(USA) 1-800-999-1360
techserv@mieleusa.com

(CDN) 1-800-565-6435
service@miele.ca

IMPORTANT SAFETY INSTRUCTIONS

Correct usage

- Do not operate the cooktop until it is properly installed in the countertop.
- This appliance is intended for residential cooking only.
- Use the appliance only for its intended purpose. The manufacturer cannot be held responsible for damages caused by improper use of the cooktop.
- Be sure drafts do not blow flammable material toward the flames or push the flames so that they extend beyond the edges of the pan.
- Install the cooktop in a room that has sufficient ventilation.
- This appliance must not be operated outdoors.
- Do not use aluminum foil to line any part of the cooktop.
- For proper lighting and performance of the burners, keep the igniters clean and dry.
- Make sure all components of the gas burners are assembled correctly before using the cooktop.
- Ensure that any burners in use are always covered with a pan.

■ Do not use pans that extend past the burner grate. Using larger pans may cause the flames to spread out and damage the surrounding countertop or other countertop appliances.

■ For safety and stability, do not use pans with a bottom diameter smaller than the burner grate.

■ Only certain types of glass, ceramic or other glazed cookware are suitable for use on a cooktop without breaking due to the sudden temperature change.

■ Do not store aerosols, gasoline, combustibles or any other flammable materials underneath or adjacent to the cooktop.

WARNING - NEVER use this appliance as a space heater to heat or warm the room. Doing so may result in carbon monoxide poisoning and overheating.

Protection from damage

■ Do not use a steam cleaner to clean the appliance. Steam could penetrate electrical components and cause a short circuit.

■ Spills containing salt or sugar should be removed immediately.

IMPORTANT SAFETY INSTRUCTIONS

Personal safety

■ The burners become very hot when in use. Make sure that no one comes in contact with them.

■ Do not leave children unattended in an area where the appliance is in use.

■ Do not store toys or items of interest to children in cabinets above or behind the cooktop. Children climbing onto the cooktop to reach these items may become seriously injured.

■ Do not allow children to operate or play with the cooktop. Keep all pans out of the reach of children.

■ Use only dry, heat resistant potholders. Moist or damp potholders used on hot surfaces can result in steam burns. Do not let the potholder touch the hot burners. Do not use towels or other bulky items near the appliance.

■ Be aware of loose fitting or hanging garments when operating the cooktop, they may present a fire hazard.

■ Do not heat unopened food containers. Built-up pressure may cause the container to burst and result in injury.

■ Do not store items on the cooktop when not in use.

■ Do not let cooking grease or other flammable materials accumulate on the appliance.

■ Do not leave the cooktop unattended while in use. Boil-overs cause smoking, and greasy spill-overs may ignite.

■ Do not use water on grease fires. Smother any fire or flame, or use a dry chemical or foam-type extinguisher.

■ Do not flambé under an exhaust hood. Flames could be drawn up into the hood by the suction or the grease filters may ignite.

■ For safety reasons the flame should be adjusted to be the same size as the bottom of the pan or smaller. Do not use small pans with high flame settings as the flames can climb the sides of the pan.

■ Only use cooking utensils suitable for cooktop use.

■ Always position pan handles and utensils inward so they do not extend over adjacent work areas, burners or the edge of the cooktop.

■ If there is a drawer directly underneath the appliance without a wooden base in between, ensure that no aerosols, combustible liquids or other easily flammable materials are kept in it. If cutlery inserts are to be placed in the drawer, these must be made of a heat-resistant material.

IMPORTANT SAFETY INSTRUCTIONS

Damage to the appliance

■ In the event of damage or a defect, turn off the appliance immediately. Turn off the gas shut off valve and disconnect completely from the electricity supply. Contact the Miele Technical Service Department. Do not use the appliance until it has been repaired.

Ensure power is not supplied to the appliance while repair work is carried out.

■ Repairs should only be performed by qualified technicians to ensure safety. Repairs and other work by unqualified persons could be dangerous. Under no circumstance open the outer casing of the appliance.

■ While the appliance is under warranty repairs should only be performed by a Miele authorized service technician. Otherwise the warranty is void.

Further safety notes

■ When using a portable appliance near the cooktop, make sure that its power cord does not come in contact with the cooktop.

■ Do not use containers made of plastic or aluminum. They may melt at high temperatures.

■ Do not heat empty pots or pans, they may be damaged.

■ Before discarding an old appliance, disconnect it from the gas and electrical supply and cut off the power cord to prevent it from becoming a hazard.

SAVE THESE INSTRUCTIONS

KM 3464 / KM 3465

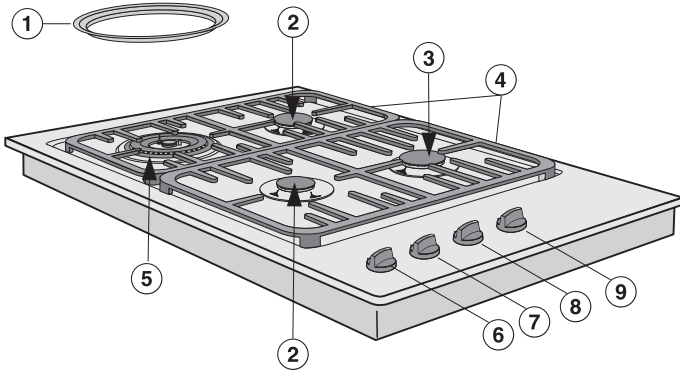

- ① Wok Ring
- ② Normal Burners
- ③ Fast Burner
- ④ Grates
(Design depends on model)
- ⑤ Wok Burner

- Control knobs:
- ⑥ Front left burner
 - ⑦ Front right burner
 - ⑧ Right rear burner
 - ⑨ Left rear burner

Guide to the cooktop

KM 3474 / KM 3475

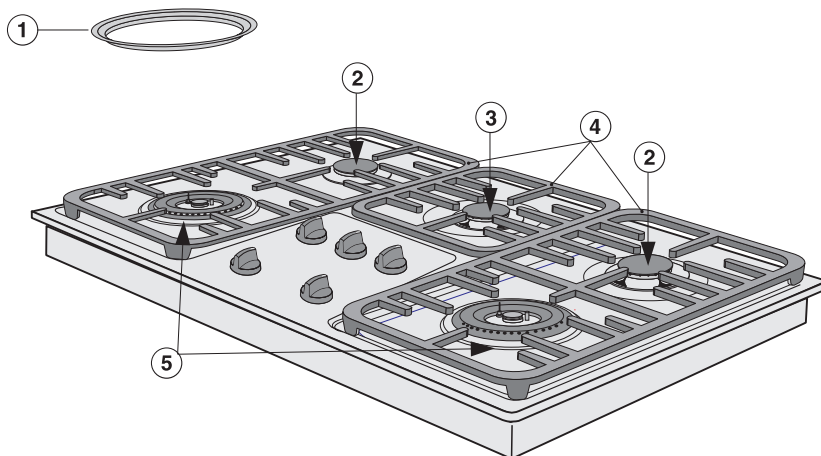

- ① Wok Ring
- ② Normal Burners
- ③ Fast Burner
- ④ Grates
(Design depends on model)
- ⑤ Wok Burners

The layout of the control knobs corresponds with the layout of the burners.

KM 3484 / KM 3485

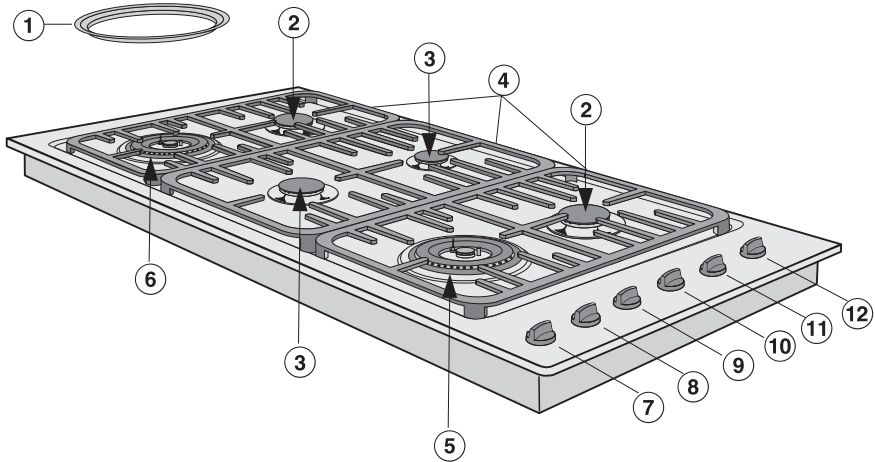

- ① Wok Ring
- ② Normal Burners
- ③ Fast Burners
- ④ Grates
(Design depends on model)
- ⑤ Wok Burner Large
- ⑥ Wok Burner Small

Control Knobs:

- ⑦ Front right burner
- ⑧ Front center burner
- ⑨ Front left burner
- ⑩ Right rear burner
- ⑪ Center rear burner
- ⑫ Left rear burner

Optional accessories

A griddle plate and simmer plate are available from your Miele dealer or Miele.

Before using the cooktop

Cleaning the cooktop

Before using for the first time clean the appliance as follows:

- Wash the gas burner assembly with a mild solution of warm water and liquid dish soap.
- Wipe dry and reassemble the parts in the proper order (see “Cleaning and care”).
- Wipe the cooktop with a damp cloth and dry thoroughly.

Metal components have a protective coating which may give off a slight odor the first time your new appliance is heated.

The harmless odor will dissipate after a short time and does not indicate a faulty connection or appliance defect.

Fast-Ignition-System

The gas cooktops are equipped with a Fast-Ignition-System which incorporates the following features:

- The control knob can be released once it is turned to the largest flame symbol.
- If the flame goes out during use, e.g. from a draft, the burner will automatically reignite.
If reignition is unsuccessful, the gas supply will automatically be shut-off (see "Safety feature").

As a result of the Fast-Ignition-System, the ignitor stays activated for a few seconds, even when the flame is already lit.

- To prevent a gas leak, the Fast-Ignition-System will click until the safety thermostat is activated.

Turning on and off / Regulating

The control knob is used to light the burner and to regulate the strength of the flame.

Normal / Fast burner

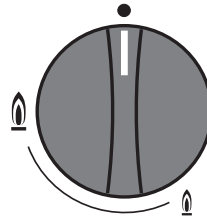

- Cooktop is turned off

🔥 Highest flame

🔥 Lowest flame

Wok burner

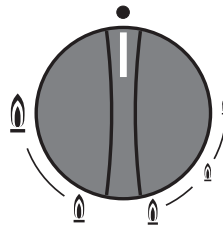

- Cooktop is turned off

🔥 Highest flame:
inner and outer burner
are both at their highest setting.

🔥 High flame:
outer burner is at the lowest setting,
inner burner is at the highest setting.

🔥 Low flame:
outer burner is turned off,
inner burner is at the highest setting.

🔥 Lowest flame:
outer burner is turned off,
inner burner is at the lowest setting.

Using the cooktop

Turning on

- To light a burner press down and turn the corresponding control knob counterclockwise to the largest flame symbol. Release the knob. The ignitor will click and ignite the gas.

The ignition process lasts about 8 - 10 seconds. The flame should light within 4 seconds. Even once the flame is lit, the ignition will continue to click for a few seconds for safety. If the burner does not light, repeat the process.

If the burner does not light on the second attempt, turn the control knob to “●” and see “Frequently asked questions”.

- Adjust the knob to the desired setting.

Regulating the wok burner

The inner and outer burners are both controlled by one control knob. There is a stop at the 6 o'clock position that requires you to press the knob down while turning it in order to get from the high flame to the low flame zone.

- To reduce the flames from a high to low setting, turn the control knob counterclockwise until you feel resistance. Press the knob down to pass the stop, then release the pressure and set the cooktop to the desired setting.

- To increase the flames from a low to high setting, turn the control knob clockwise until you reach the stop. Press the knob down to pass the stop, then release the pressure and set the cooktop to the desired setting.



Since the outer portion of the flame is much hotter than the center, the flame should be set so that it does not spread beyond the sides of the pan. Flame tips which extend beyond the sides of the pan are hazardous.

Turning off

- Turn the control knob clockwise to “●”.

This stops the flow of gas and turns off the cooktop.

The knob must only be turned left to turn the appliance on and right to turn it off.

If the knob is turned,
- on without pressing it down first,
- clockwise past the 12 o'clock position, or
- counterclockwise past the smallest flame symbol,
parts of the cooktop could be damaged. The manufacturer cannot be held responsible for these damages.

Pan size

- Set the cooktop to a high flame when using a large diameter pan and low flame when using small diameter pans.

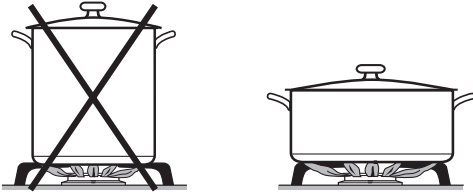

- Generally, wide / shallow pans will heat quicker and cook more evenly than narrow / tall ones.
- Using oversized pans may cause the flames to spread out and damage the surrounding countertop or other countertop appliances. The proper pan size will also improve efficiency.
- Do not use small pans with high flame settings, the flames may climb the sides of the pan.
- Pots with a smaller diameter than the pan support and pots that do not sit securely (without wobbling) are hazardous and should not be used.

Suitable pans

Unlike pans used on an electric cooktop, the bases do not need to be even for good results.

Thick pan bases will give more even results, as hot spots are reduced due to better heat distribution.

Thin pan bases will conduct the heat faster but not as evenly as thick pan bases. Stir the food frequently to prevent burning.

Wok burners

You can use a wok on these burners without any additional rings, trivets, etc.

If you wish to use the wok ring, for extra stability, attach it as shown (depending on your grates).

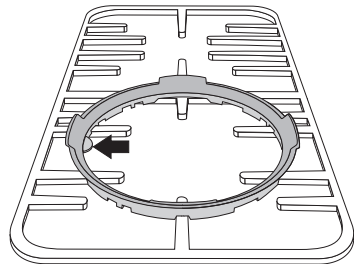

Using the cooktop

Safety feature

This appliance is equipped with an Ignition Safety Control. This control cuts the gas supply if the flame goes out and reignition is unsuccessful.

- To reignite the burner, turn the control knob to “●”, then follow the procedure outlined in “Turning on and off / Regulating”.

This safety feature is not operated by electricity, it will be active even if the appliance is in use during a power failure.

Using the cooktop during a power failure

If there is an interruption to the electrical supply the gas can be ignited using a match.

- Press down and turn the desired control knob counterclockwise to the largest flame symbol.
- While holding down the knob, light the gas at the burner with a match.
- When the flame appears, keep the control knob pressed in for 8 - 10 seconds to allow for the Ignition Safety Control to reach operating temperature.

Never use a steam cleaner to clean this cooktop. Pressurized steam could cause permanent damage to the surface and to components for which the manufacturer cannot accept responsibility.

Do not use any sharp or pointed objects which could damage the seal between the frame and the countertop.

Never use scouring agents, pads, abrasive cleaning agents, or strong cleaners, e.g. oven sprays, stain or rust removers, these could damage the surface of the appliance.

Keep the ignitor in the burner dry. If it gets wet it will not spark.

Dry your cooktop thoroughly after cleaning it to prevent lime deposits.

Spills containing salt or sugar should be cleaned immediately.

Cooktop

Let the appliance cool to a safe temperature before removing the grates.

- Clean the grates, cooktop and knobs with a sponge and a mild solution of warm water and liquid dish soap.
- Soak baked or hardened spills. Dry the cooktop and grates thoroughly after cleaning.

The stainless steel surfaces can be cleaned using a non-abrasive stainless steel cleaner.

To help prevent resoiling, a conditioner for stainless steel can also be used. Apply sparingly with even pressure.

Stainless steel colored knobs

These controls may become discolored or damaged if not cleaned regularly.

Do not use a stainless steel cleaner on the knobs.

Cleaning and care

Burners

The burners can be dismantled and cleaned when cool.

- Remove the burner parts and wash them in a solution of hot water and liquid dish soap. Dry them thoroughly. Make sure that the flame holes are clean and completely dry.
- Wipe the burner base clean with a damp cloth and then dry.
- Gently wipe the ignitor and ignition safety control with a slightly damp cloth, and then wipe dry.

Make sure that no liquid gets into the appliance.

Reassembling the normal and fast burners

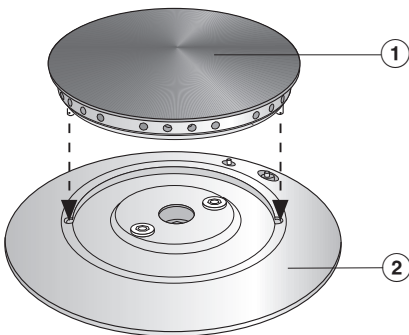

- Place the burner cap, ①, onto the burner base, ②, so that the notches fit into the holes (see arrows).

Reassembling the wok burner

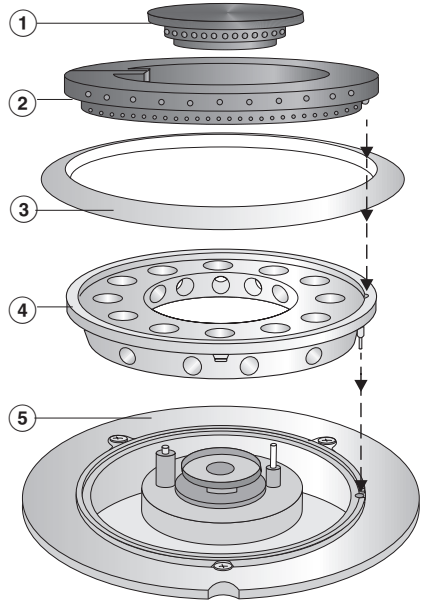

- Place the burner head, ④, onto the burner base, ⑤.
- Fit the burner ring, ③.
- Fit the large burner cap, ②, onto the burner head, ④.
- Seat the small burner cap, ①.
- Put the grates in place.

Be careful not to mix up the parts. Make sure that all the locating tabs and notches align exactly.

Frequently asked questions

 Repairs should only be carried out by an authorized technician in accordance with local and national safety regulations. Unauthorized repairs could cause injury or appliance damage. The manufacturer cannot be held responsible for unauthorized work.

The burners do not ignite after several attempts.

Possible fault	Fix
<ul style="list-style-type: none">– The burners are assembled incorrectly.– The gas valve is closed.– The burners are wet and soiled and/or the flame holes in the burners are soiled and clogged.– The igniters are wet.– The cooktop is not plugged in and the circuit breaker has tripped.	<ul style="list-style-type: none">– Reassemble the burners as shown in “Cleaning and Care - Burners”.– Open the gas valve.– Clean the burners. See “Cleaning and Care”.– Dry the igniters.– Plug the cooktop in and restore power. If lack of power is the problem, the cooktop can be lit with a match. See “Using the cooktop during a power failure”.

The flame goes out after being lit.

<ul style="list-style-type: none">– The burners are assembled incorrectly.– The flame holes in the burners are soiled and clogged.	<ul style="list-style-type: none">– Reassemble the burners as shown in “Cleaning and Care - Burners”.– Clean the burners. See “Cleaning and Care”.
---	---

The igniters no longer work.

<ul style="list-style-type: none">– Residue has been built up between the ignitor and the burner.– Make sure the ignitor is dry.	<ul style="list-style-type: none">– Clean the burners. See “Cleaning and Care”.– Dry the igniters.
---	---

The flame appears different than usual.

<ul style="list-style-type: none">– The burners are assembled incorrectly.	<ul style="list-style-type: none">– Reassemble the burners as shown in “Cleaning and Care - Burners”.
--	---

Technical Service

In the event of a fault which you cannot easily fix yourself, please contact the Miele Technical Service Department at the address on the back of this booklet.

When contacting Technical Service please quote the serial number and model of the cooktop. This information is visible on the silver data plate supplied with the cooktop.

Adhere the data plate sticker to the box below:

MieleCare

MieleCare, our Extended Service Contract program; gives you the assurance of knowing that your appliance investment is covered by 5 years of worry free ownership.

MieleCare is the only Extended Service Contract in the industry that guarantees repairs by a Miele Authorized Service Provider using genuine Miele parts. Only genuine Miele parts installed by factory trained professionals can guarantee the safety, reliability and longevity of your Miele appliance.

Please note that unless expressly approved in writing by the Miele Service department, Extended Service Contracts offered by other providers for Miele products will not be recognized by Miele. Our goal is to prevent unauthorized (and untrained) service personnel from working on your Miele products, possibly doing further damage to them, you and/or your home.

To learn more about **MieleCare** Extended Service Contracts, please contact your appliance dealer or visit us online at:

www.store.miele.com



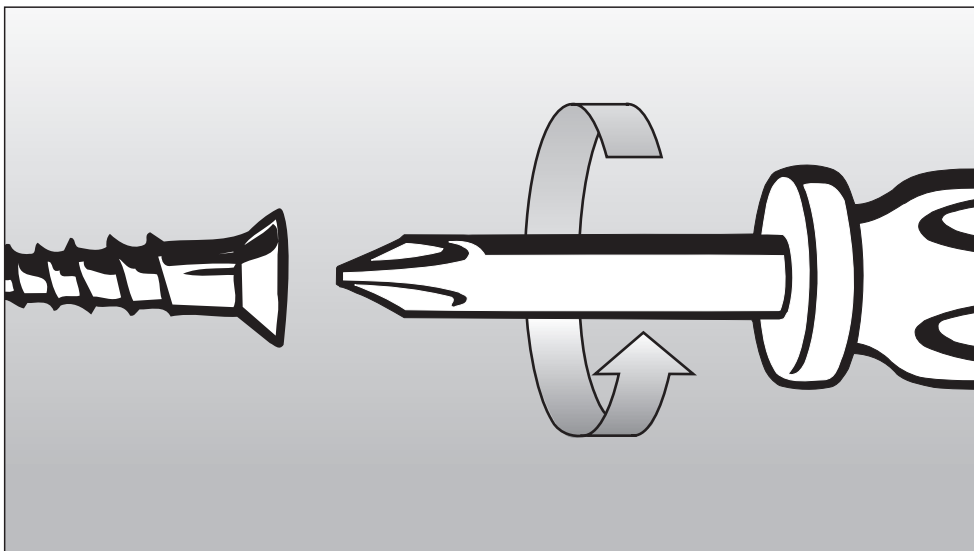

Installation Instructions

To prevent accidents
and machine damage
read these instructions
before
installation or use.

IMPORTANT SAFETY INSTRUCTIONS

Installation

The minimum distances given in these Installation instructions are to combustible surfaces, and must be observed to ensure safe operation. Failure to do so increases the risk of fire.

The cabinetry and venting hood should be installed first to prevent damage to the cooktop.

- Gas appliances should only be installed in a well ventilated area.
- The countertop must be bonded with heat resistant (212 °F/100 °C) adhesive to prevent distortion or dissolving.
- The cooktop should only be installed as shown in the illustrations while maintaining the required safety distances shown. Do not install the cooktop between two tall cabinets, this is a fire hazard.

① = indicates cooktop cut-out
② = minimum distance between cut-out and a tall cabinet:
12" (305 mm)

■ This appliance has not been designed for maritime use or for use in mobile installations such as recreational vehicles or aircraft. However, under certain conditions it may be possible for installation in these applications. Please contact the Miele Technical Service Department with specific requirements.

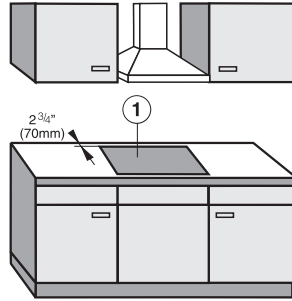

recommended

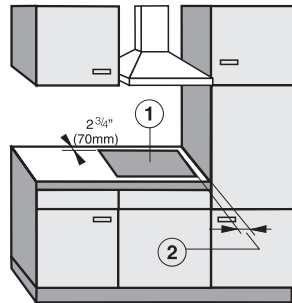

not recommended

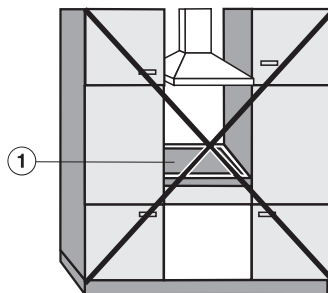

not allowed

IMPORTANT SAFETY INSTRUCTIONS

The cooktop must not be installed over a dishwasher, washer, dryer, refrigerator or freezer. Heat radiated by the cooktop may damage the appliances.

Deep fat fryers must not be installed next to gas cooktops. Gas flames can ignite splattering oil. A distance of at least 12" (305 mm) should be maintained between these two appliances. The minimum distance between two cooktops must be 4" (100 mm).

Install the appliance so that the power cord or gas piping does not come into contact with any portion of the cooktop which may become hot during use.

This appliance must be installed with its own shut off valve and the included gas pressure regulator. Both the valve and the regulator must be easily accessible to the consumer after the appliance is installed.

This appliance must be disconnected from the gas supply during any pressure testing of the system performed in excess of $\frac{1}{2}$ psi (3.5 kPa). This appliance must be isolated at test pressures equal to or less than $\frac{1}{2}$ psi (3.5 kPa).

Any pipe connections must be made using a thread sealant approved for gas connections. Failure to correctly install these items could lead to a gas leak and subsequent explosion.

Safety distances above the appliance

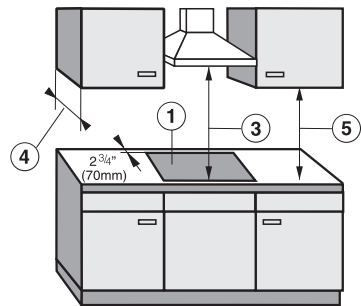

There must be a safety distance of at least 30" (760 mm), ③, between the appliance and any objects above it. The overhead cabinet depth, ④, if unprotected, must not exceed 13" (330 mm). The minimum distance of combustible surfaces located above and to the sides of the cooktop, ⑤, is 18" (457 mm).

If the cabinet manufacturer recommends a greater distance, follow that manufacturer's recommendation.

When installing the cooktop under a venting hood, always observe the minimum distance recommended by the hood manufacturer.

Keep this instruction book in a safe place for reference and pass it on to any future user.

Appliance dimensions

KM 3464 / KM 3465

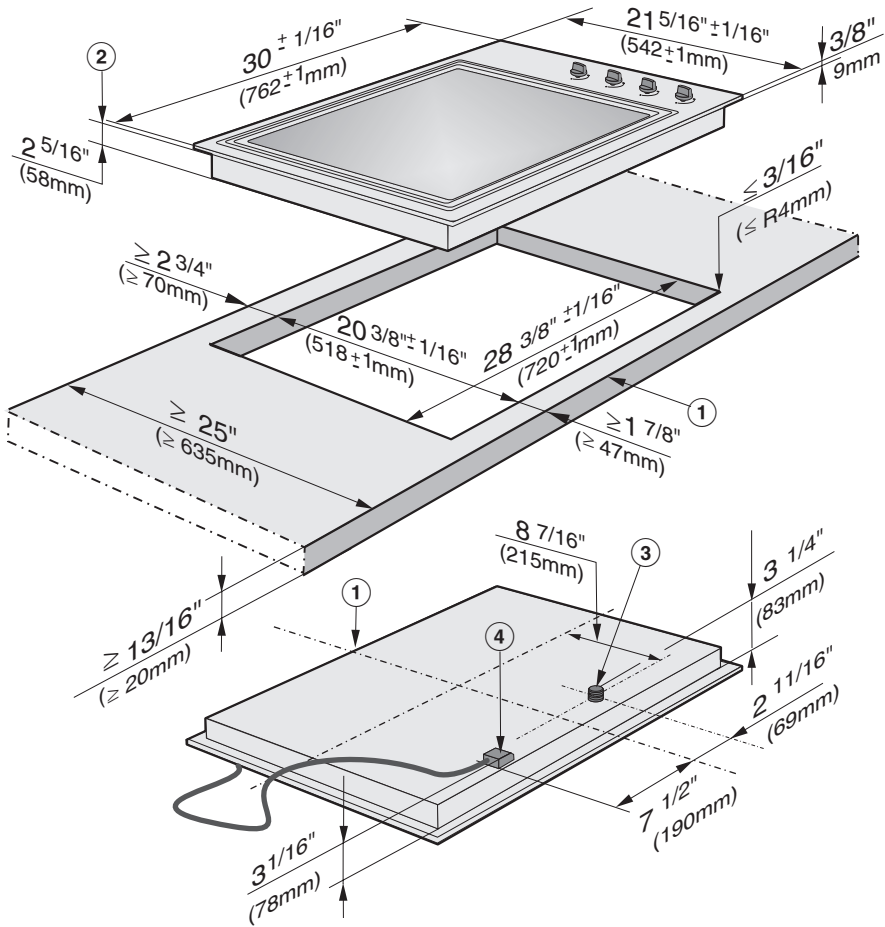

- ① Front
- ② Built-in depth
- ③ Gas connection R 1/2" NPT
- ④ Mains connection box

Appliance dimensions

KM 3474 / KM 3475

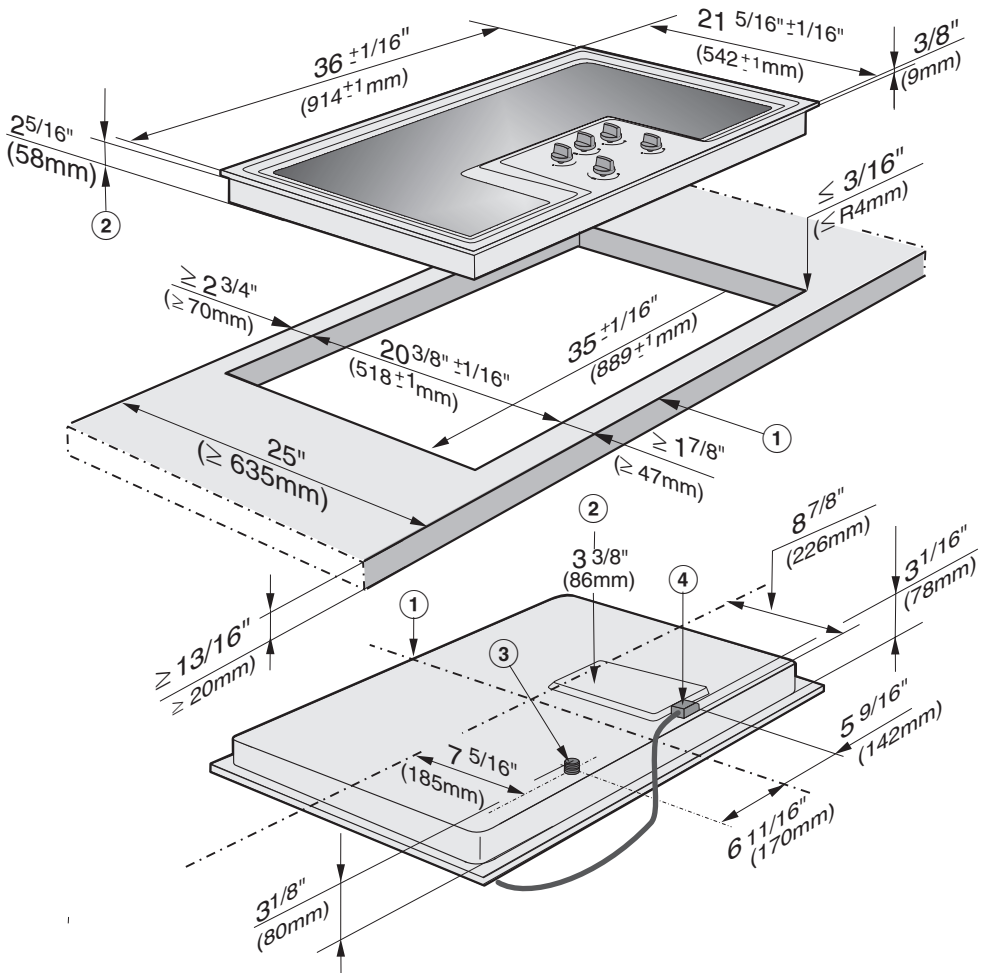

- ① Front
- ② Built-in depth
- ③ Gas connection R ½" NPT
- ④ Mains connection box

Appliance dimensions

KM 3484 / KM 3485

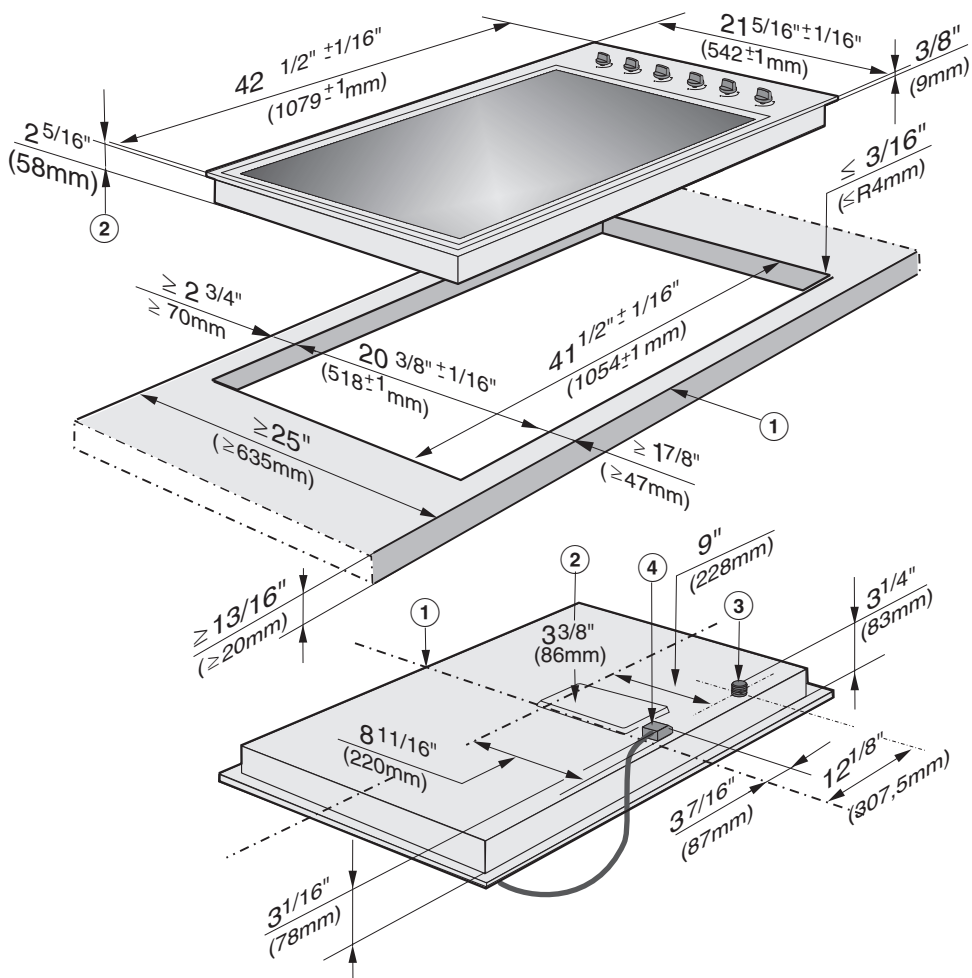

- ① Front
- ② Built-in depth
- ③ Gas connection R ½" NPT
- ④ Mains connection box

- Prepare the work top cut-out as shown in the diagram.
Remember to maintain the minimum safety distances to combustible surfaces:
 - 2 $\frac{3}{4}$ " (70 mm) between the cut-out and the back wall and
 - 12" (305 mm) between the cut-out and a side wall or tall unit to the right or left of the cut-out.(See "Important Safety instructions").
- Seal the cut surfaces with a suitable heat-resistant sealant to avoid swelling caused by moisture.

If during installation, the corners of the frame are not flush with the work top surface, the corner radius (max. $\frac{3}{16}$ " [4 mm]) can be carefully filed to fit.

Installation

Setting the cooktop into place

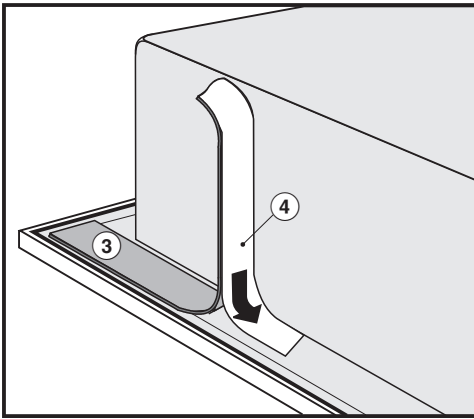

- After removing the protective backing, ④, stick the supplied seal, ③, under the edge of the cooktop.
- Screw the gas regulator onto the nipple underneath the cooktop. (See "Gas Connection - Gas pressure regulator".)
- Feed the power cord through the cut-out to the power outlet.
- Set the cooktop in the cut-out and center it.

Install the appliance so that the power cord and gas piping does not come in contact with any portion of the cooktop which may become hot during use.

Securing the cooktop

- Secure the cooktop with the included fixing bracket.

Countertop $1\frac{3}{16}$ " (20 mm)

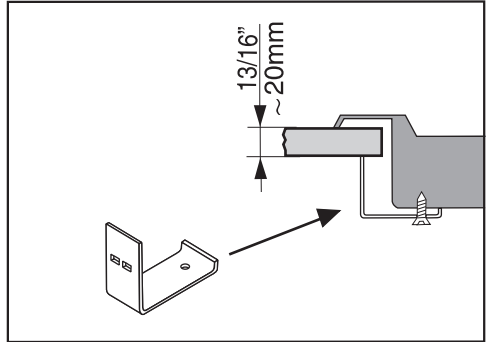

Countertop $1\frac{9}{16}$ " (40 mm)

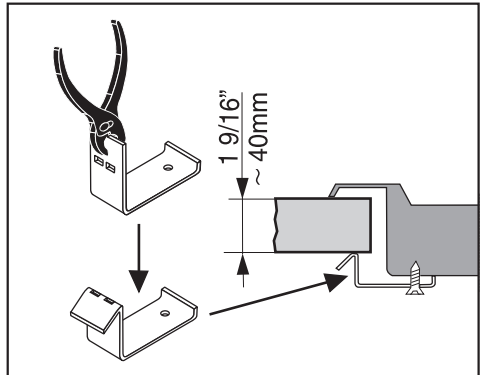

Sealing

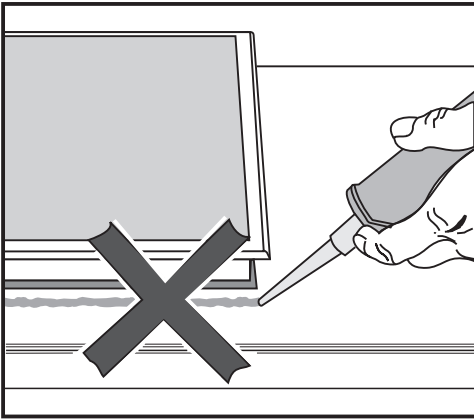

The cooktop must not be permanently sealed into the countertop when installed. The sealing strip under the edge of the cooktop provides a sufficient enough seal.

If the cooktop is sealed into position, the countertop or the appliance may be damaged if the cooktop needs to be removed for maintenance or service.

Electrical connection

This appliance must be grounded according to local or national codes.

All electrical work should be performed by a qualified electrician in accordance with local codes and with the:

- National Electrical Code ANSI / NFPA No. 70 for the USA
- or
- Canadian Electrical Code Part I for Canada (CSA Standard C 22.1).

WARNING

Disconnect the appliance from the main power supply before installation or service. To reduce the risk of electric shock, make sure that the appliance is properly grounded after installation.

This appliance is equipped with a three-prong grounding plug to prevent shock hazards. It should be plugged directly into a properly grounded outlet. Do not cut or remove the grounding prong from the plug. If the plug does not fit the outlet, have the proper outlet installed by a licensed electrician.

To guarantee the electrical safety of this appliance, continuity must exist between the appliance and an effective grounding system. It is imperative that this basic safety requirement be met. If there is any doubt, have the electrical system of the house checked by a qualified electrician.

The manufacturer cannot be held responsible for damages caused by the lack, or inadequacy, of an effective grounding system.

Power supply

The automatic ignition requires that the cooktop be connected to a 120 VAC, 60 Hz power supply. The supply line should be protected by a 15 A fuse.

Actual power consumption (during ignition only) is 25 W.

This appliance is equipped with a 4 ft. (1.2 m) long power cord that is ready for connection to the appropriate outlet.

Place the power outlet so that it is accessible after the appliance has been installed in the countertop.

Note to the installer

Please leave these instructions with the consumer or the appliance.

Wiring diagram

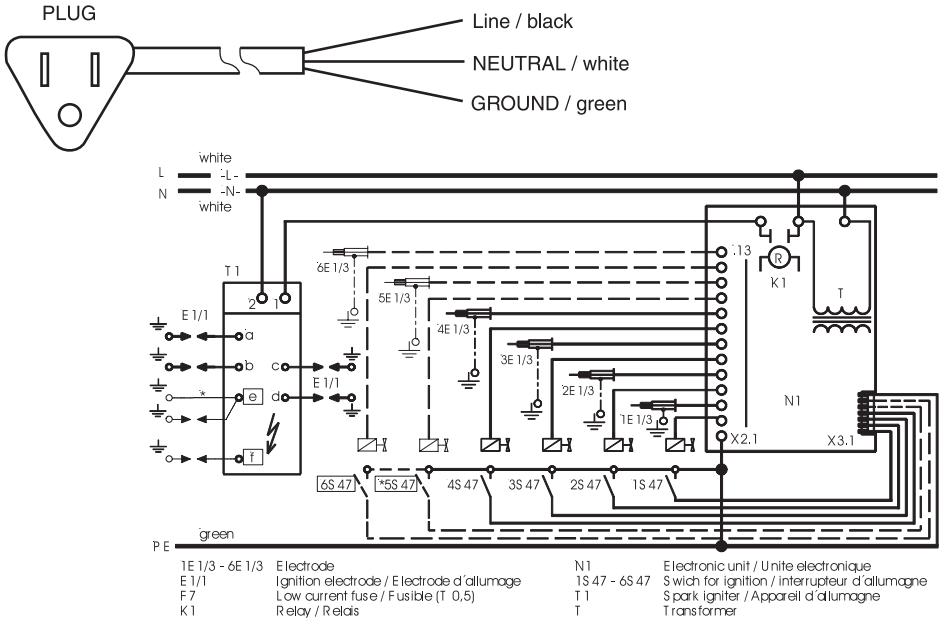

⚠ Caution: Label all wires prior to disconnection when servicing controls. Wiring errors can cause improper and dangerous operation. Verify proper operation after servicing.

Gas connection

Installation and service must be performed by a qualified installer, service agency or gas supplier.

In Massachusetts a licensed plumber / gas fitter is required.

This appliance must be installed with its own shut off valve and the included gas pressure regulator. Both the valve and the regulator must be easily accessible to the consumer to turn on or shut off the gas supply after the appliance is installed.

This appliance and its individual shut off valve must be disconnected from the gas supply during any pressure testing of that system performed in excess of $\frac{1}{2}$ psi (3.5 kPa). The appliance must be isolated from the gas supply line by closing its individual manual shut off valve at test pressures equal to or less than $\frac{1}{2}$ psi (3.5 kPa).

Any pipe connections must be made using a thread sealant approved for gas connections. Failure to correctly install these items could lead to a gas leak and subsequent explosion.

The gas connection must be made in accordance with local codes or, in the absence of local codes, with

- the National Fuel Gas Code, ANSI Z 21.1 / NFPA 54 for the USA
- or
- the current Can / CGA B 149.1 and .2 Installation Codes for gas burning appliances for Canada.

Make sure that the maximum gas supply pressure before the gas pressure regulator is never more than $\frac{1}{2}$ psi for both natural gas or LP gas.

The minimum required gas pressure to get the required gas input is
4" w.c. for natural gas
10" w.c. for LP gas.

Gas pressure regulator

A pressure regulator that is convertible from natural to LP gas (Propane) or vice versa is included with the appliance. The included regulator corresponds with the gas type of the cooktop. Verify before installing.

The adjusted pressure is:
natural gas - 4" w.c.
LP gas - 10" w.c.

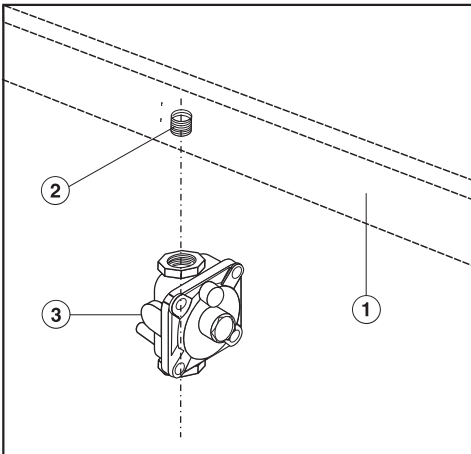

- ① Cooktop
- ② 1/2" NPT
- ③ Regulator

As shown in the above diagram, the included regulator **must** be used when connecting the Miele cooktop to your gas supply. This item has been customized by Miele to meet all applicable safety requirements. Make sure the regulator is easily accessible for adjustment after the appliance has been installed.

For convenience, an AGA or CGA approved flexible stainless steel gas hose (accordion type) may be used between the gas connection and the regulator. This will allow the appliance to be lifted out of the countertop for cleaning or servicing. Make sure that any drawers, cabinet doors, etc., do not rub on this gas hose.

Do not use any regulator unless it has been supplied by Miele. Doing so may cause a gas leak.

If there is any doubt concerning installation contact the Miele Technical Service Department:

(USA) 1-800-999-1360
techserv@mieleusa.com

(CDN) 1-800-565-6435
service@miele.ca

After connecting the appliance check all fittings for gas leaks e.g. with soapy water.

When installed properly, the flame will be steady and quiet. It will also have a sharp, blue inner core that will vary in length proportional to the burner size. Flame adjustment will not be necessary.

Gas connection

Nominal Rating Table

	KM 3464 / KM 3465		KM 3474 / KM 3475		KM 3484 / KM 3485	
	NG / LP-Gas		NG / LP-Gas		NG / LP-Gas	
Normal burner	BTU/hr	kW	BTU/hr	kW	BTU/hr	kW
Max. output	9,000	2.6	9,000	2.6	9,000	2.6
Min. output	1,700	0.50	1,700	0.50	1,700	0.5
Fast burner						
Max. output	12,000	3.5	12,000	3.5	12,000	3.5
Min. output	2,500	0.73	2,500	0.73	2,500	0.73
Wok burner left						
Max. output	15,300	4.5	15,300	4.5	15,300	4.5
Min. output	620	0.18	620	0.18	620	0.18
Wok burner right						
Max. output	-	-	15,300	4.5	16,500	4.8
Min. output	-	-	620	0.18	620	0.18
All burners						
Max. output	45,300	13.2	60,600	17.7	73,800	21.6

Converting to another type of gas

The cooktop should have been ordered for connection to either natural or LP gas.

If the cooktop is not configured for the proper type of gas connection please contact your Miele Dealer.

Help protect our environment

Disposal of packing materials

The cardboard box and packing materials are biodegradable and recyclable. Please recycle.

Disposal of an old appliance

Old appliances contain materials that can be recycled. Please contact your local recycling center about the possibility of recycling these materials.

Before discarding an old appliance, disconnect it from the gas and electrical supply and cut off the power cord to prevent it from becoming a hazard.

When contacting the Technical Service,
please quote the model and serial number
of your appliance.



Miele, Inc. (USA)

National Headquarters

9 Independence Way

Princeton, NJ 08540

Phone: 800-843-7231

609-419-9898

Fax: 609-419-4298

www.miele.com

**Technical Service & Support
Nationwide**

Phone: 800-999-1360

Fax: 888-586-8056

Miele Limited (CDN)

National Headquarters

55G East Beaver Creek Road

Richmond Hill, ON L4B 1E5

Phone: 800-643-5381

905-707-1171

Fax: 905-707-0177

www.miele.ca

info@miele.ca (general enquiries)

professional@miele.ca (commercial
enquiries)

Mielecare National Service

Phone: 800-565-6435

905-850-7456

Fax: 905-850-6651

service@miele.ca (Tech. Service)