

OUTDOOR Corner Cabinet Installation Manual MODEL# MK06SS304

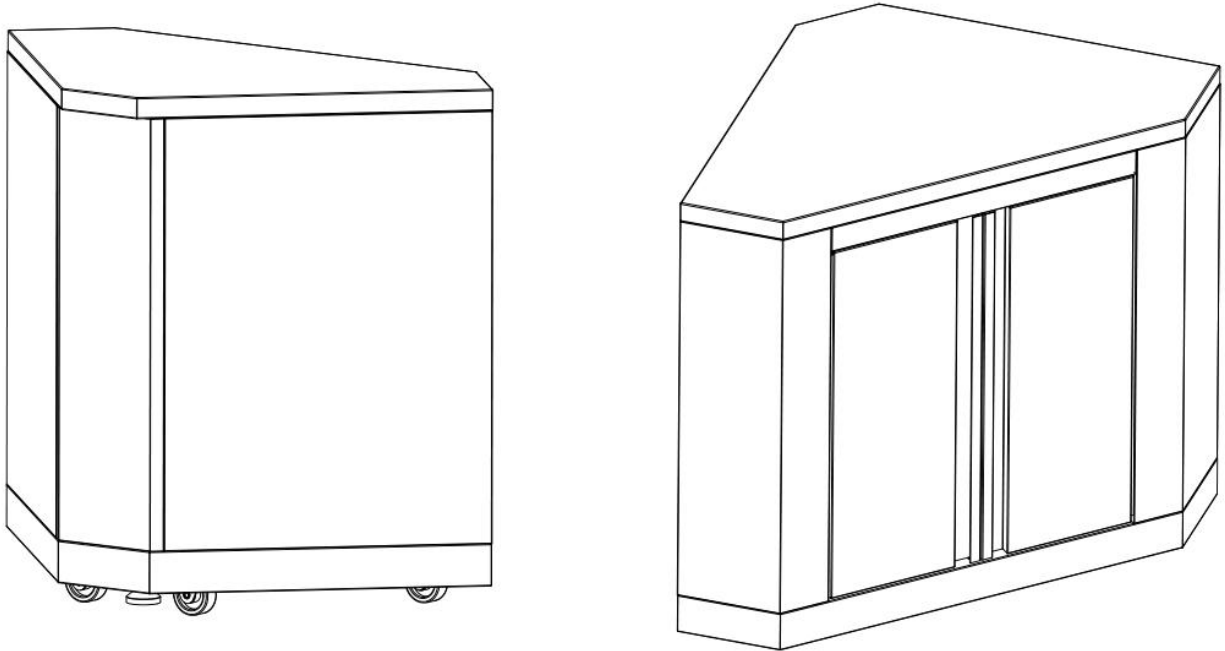

IMPORTANT:

Save for electrical inspector's use.

Installer: Leave installation instructions with the homeowner.

Homeowner: Keep installation instructions for future reference

Welcome

Thank you for purchasing our outdoor kitchen appliance! We appreciate your business and we recommend that you read this entire User's Manual before operating your new appliance for the first time.

This manual contains instructions on how to properly install and set up your new range, as well as insights into the unique features that our product offers. Please keep this manual for future reference, as it contains answers to questions that you might have as you begin to cook.

Thank you

This manual applies to the following models' series:

Model # MK06SS304 (Outdoor Corner Cabinet)

Parts Explosive Pictures

Thor Kitchen Corner Cabinet Parts Lists and Explosive Picture

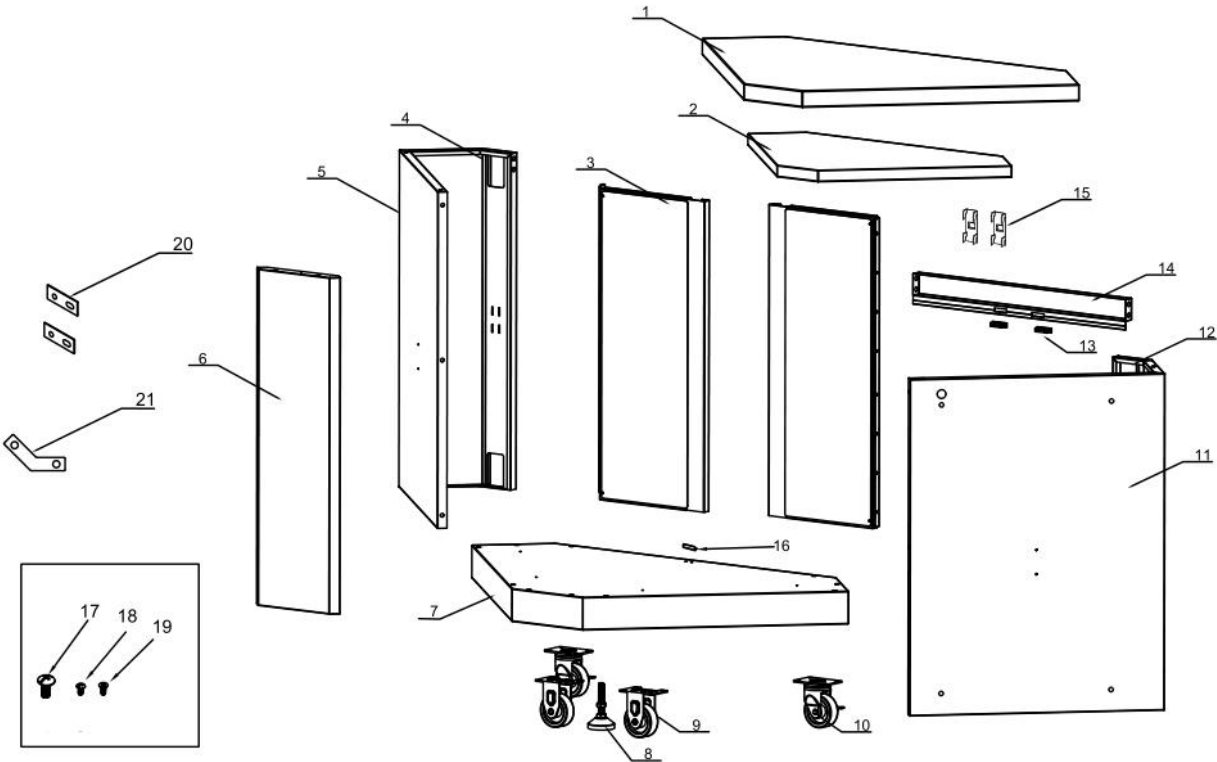

Parts List

Explosive #	Part #	Part Name	Quantity
1	20.01.008054-000-A0	Countertop welding assembly	1
2	20.01.001063-000-A0	Laminate welding assembly	1
3	22.99.009228-000-A0	Door welding assembly	2
4	20.01.001059-000-A0	Left side panel A welding assembly	1
5	20.01.001060-000-A0	Left side panel B welding assembly	1
6	20.01.001064-000-A0	Front panel welding assembly	1
7	20.01.008077-000-A0	Bottom panel welding assembly	1
8	05.01.008004-000-A0	Supporting leg	2
9	05.10.000122-000-A0	Fixed caster	2
10	05.10.000123-000-A0	Universal caster	2
11	20.01.001062-000-A0	Right side panel B welding assembly	1
12	20.01.001061-000-A0	Left side panel A welding assembly	1
13	05.12.008009-000-A0	Door magnetic	2
14	20.05.008086-000-A0	Beam welding assembly	1
15	04.04.008570-000-A0	Laminate welding holder	2
16	04.01.002596-000-A1	Door barrier strip	1
17	06.02.000093-000-A0	¼" Philips thumb head screw with anti-slip design	58
18	06.10.000042-000-A0	Philips thumb head screw	2
19	06.11.008056-000-A0	flat head screw	16
20	04.01.002580-000-A0	cabinet back connecting plate	2
21	04.01.002640-000-A0	corner cabinet front connecting plate	1

Product Dimension

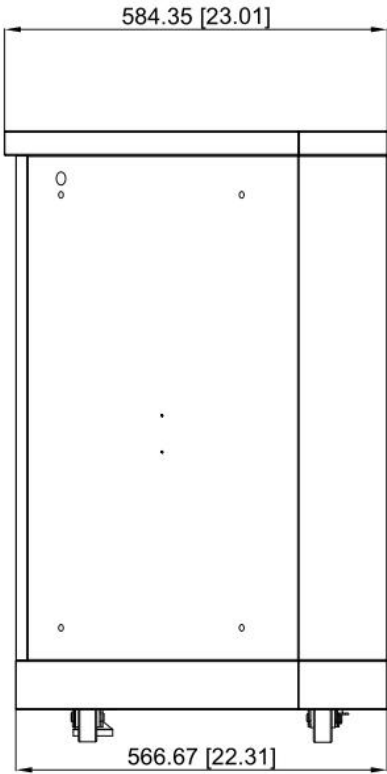
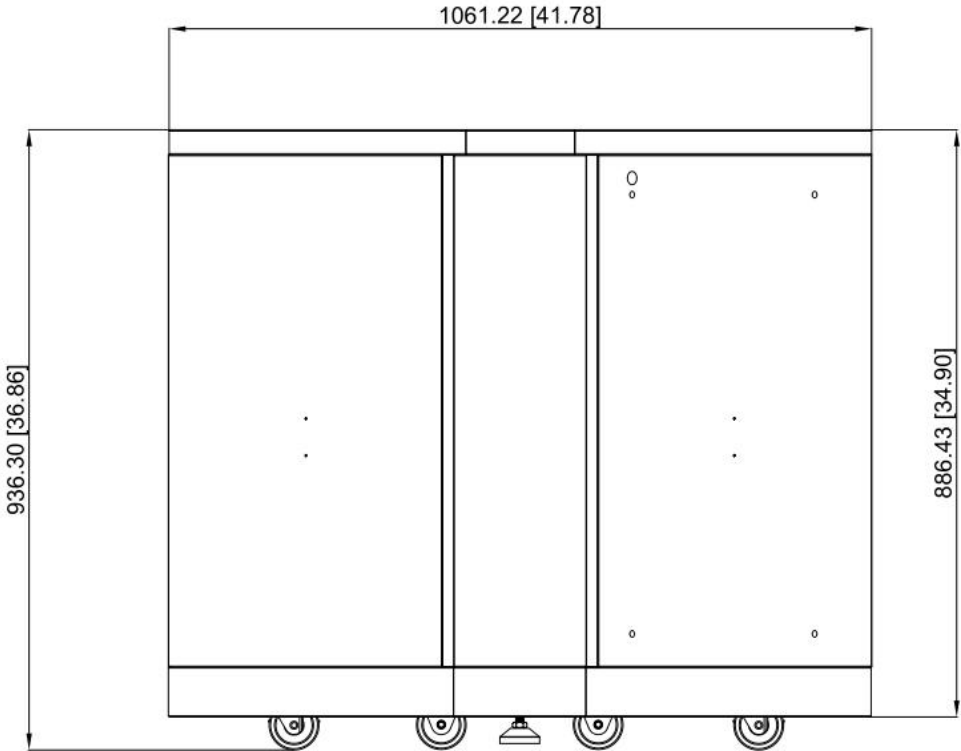

Cabinet Installation

Step 1

1. Reverse the bottom welding part (Part # 7) and put 1 pc supporting leg (Part # 8) to Part # 7. Use hand to adjust the leg to the suitable position;
2. Use 16 pcs $\frac{1}{4}$ " flat Philip's head screw (Part #17) to connect 2 pcs fixed casters (Part # 9) and 2 pcs universal casters with brake (Part # 10) to Part #7;
3. Reverse Part # 7 and use 2 pcs Philips thumb head screw (Part # 18) to install Door barrier strip (Part # 18) to Part # 7.

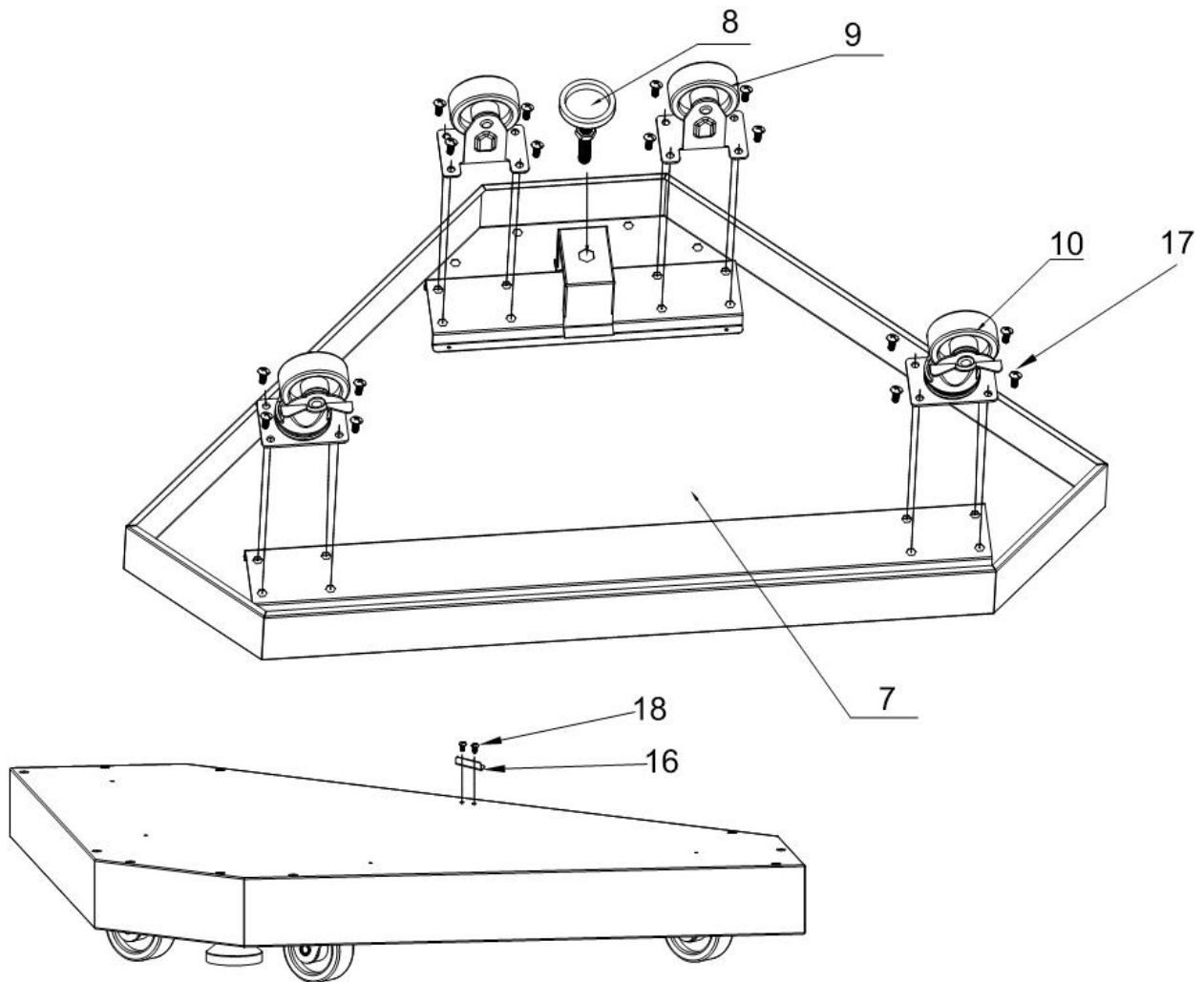

Step 2

1. Use 3 pcs $\frac{1}{4}$ " flat Philip's head screw (Part # 17) to connect left side panel A (Part # 4) to Part # 5;
2. Use 3 pcs $\frac{1}{4}$ " flat Philip's head screw (Part # 17) to connect right side panel a (Part # 12) to Part # 11;
3. Do not over-tighten all the screws until parts are lined up.

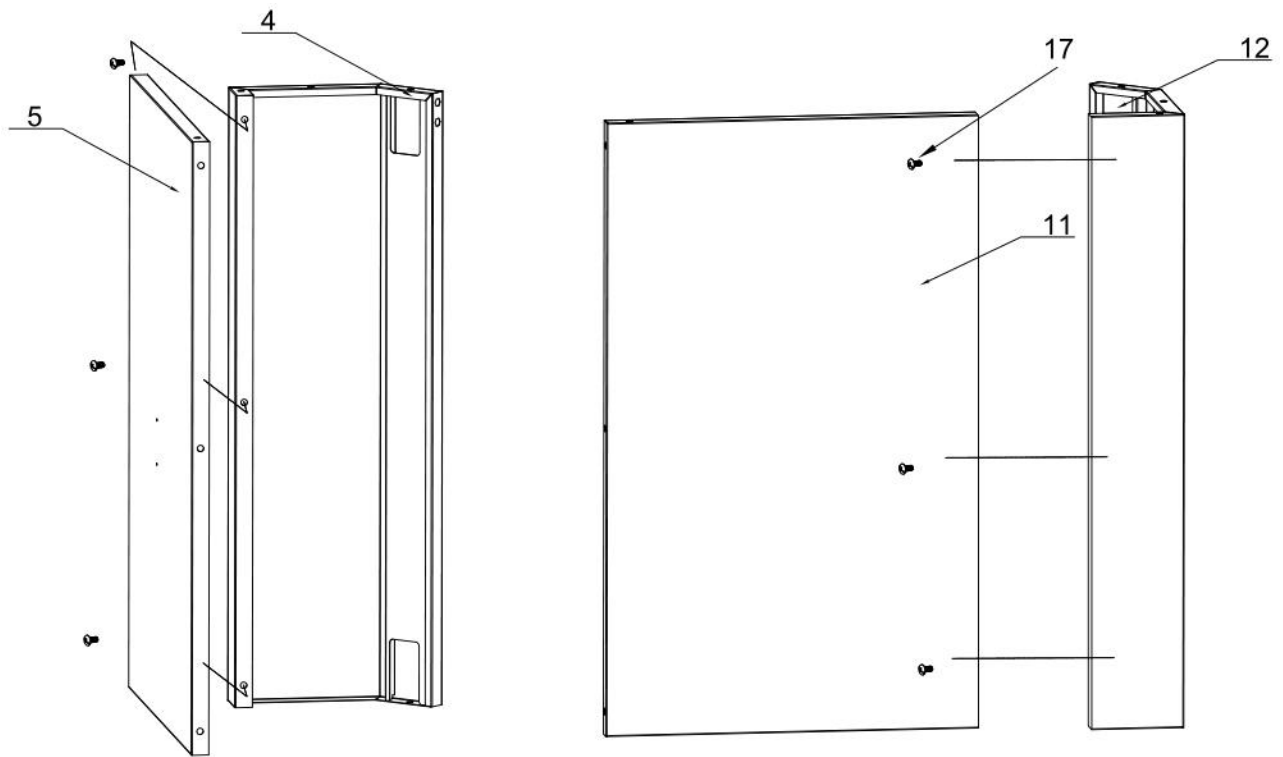

Step 3

1. Use 6 pcs $\frac{1}{4}$ " flat Philip's head screw (Part # 15) to connect front panel (Part # 6) to Part #5 and #11. Do not over-tighten all the screws until parts are lined up.

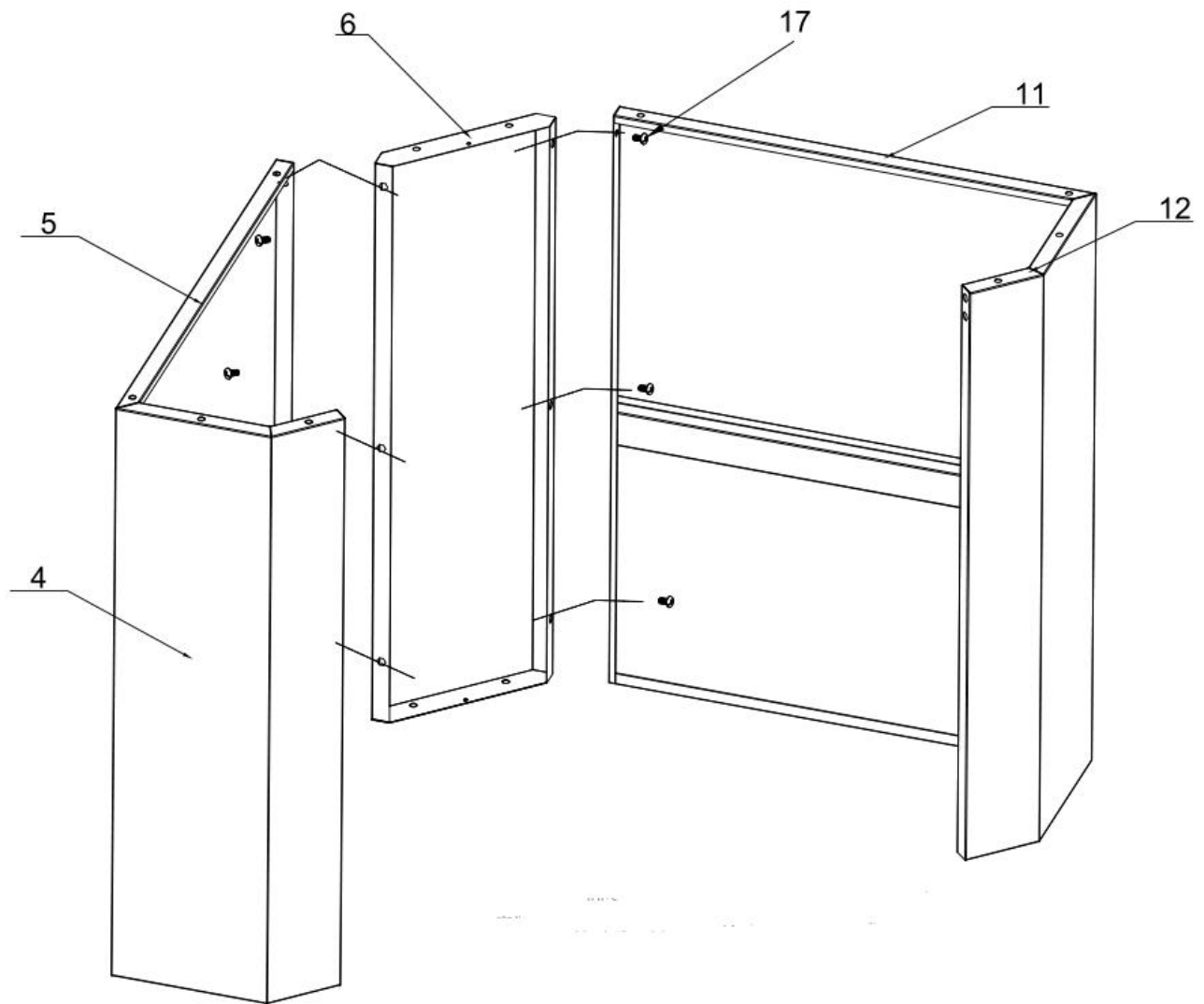

Step 4

1. Use 4 pcs Philips thumb head screw with anti-slip design (Part # 17) to connect Left side panel A welding assembly (Part # 4) and Left side panel B welding assembly (Part # 5) to Bottom panel welding assembly (Part # 7);
2. Use 4 pcs Part # 17 to connect Right side panel B welding assembly (Part # 11) and Left side panel A welding assembly (Part # 12) to Part # 7;
3. Use 2 pcs Part 17 to connect Front panel welding assembly (Part # 6) to Part # 7.
4. Do not over-tighten all the screws until parts are lined up.

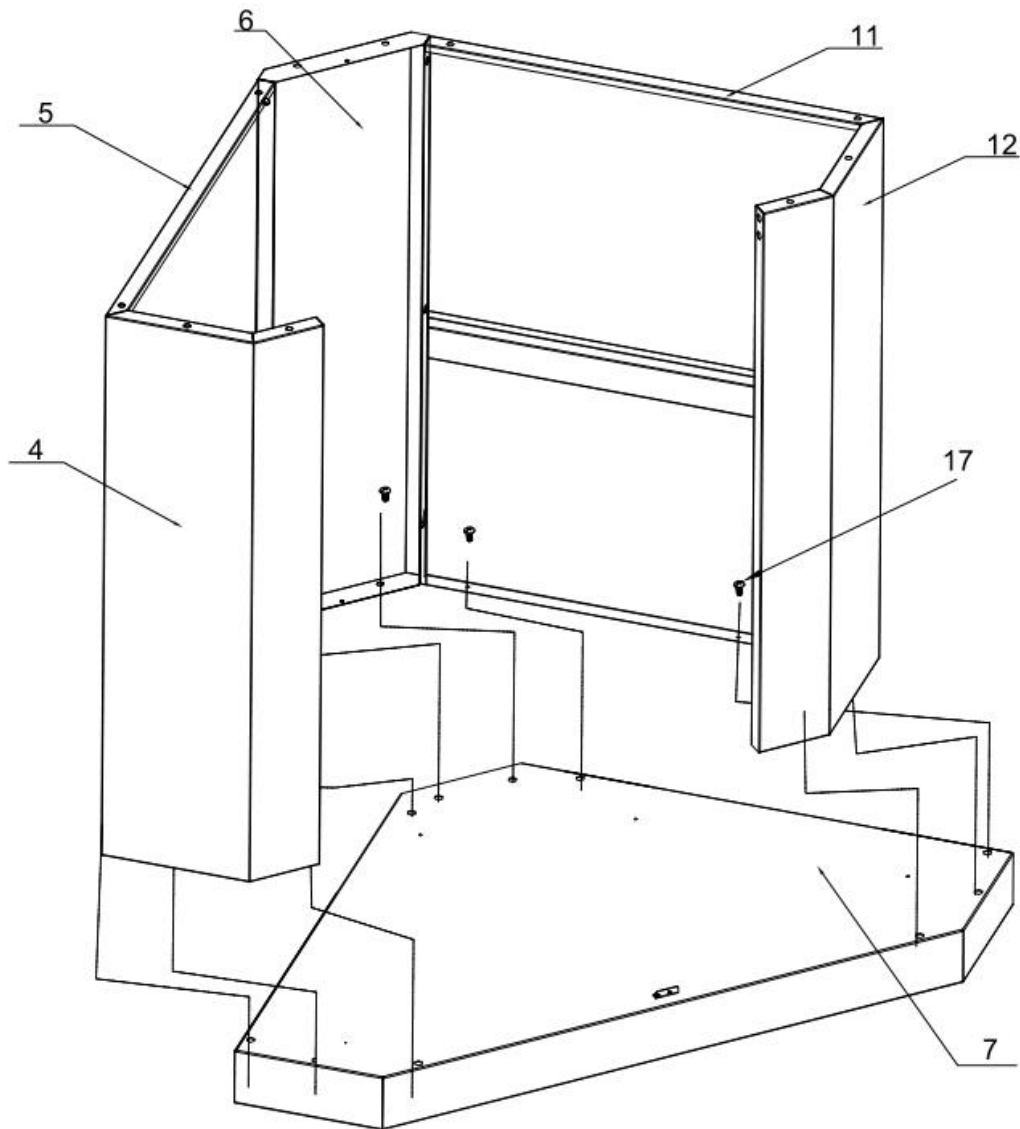

Step 5

1. Use 4 pcs Part # 17 to connect Beam welding assembly (Part # 14) to Part # 4 and Part # 12. Do not over-tighten all the screws until parts are lined up.

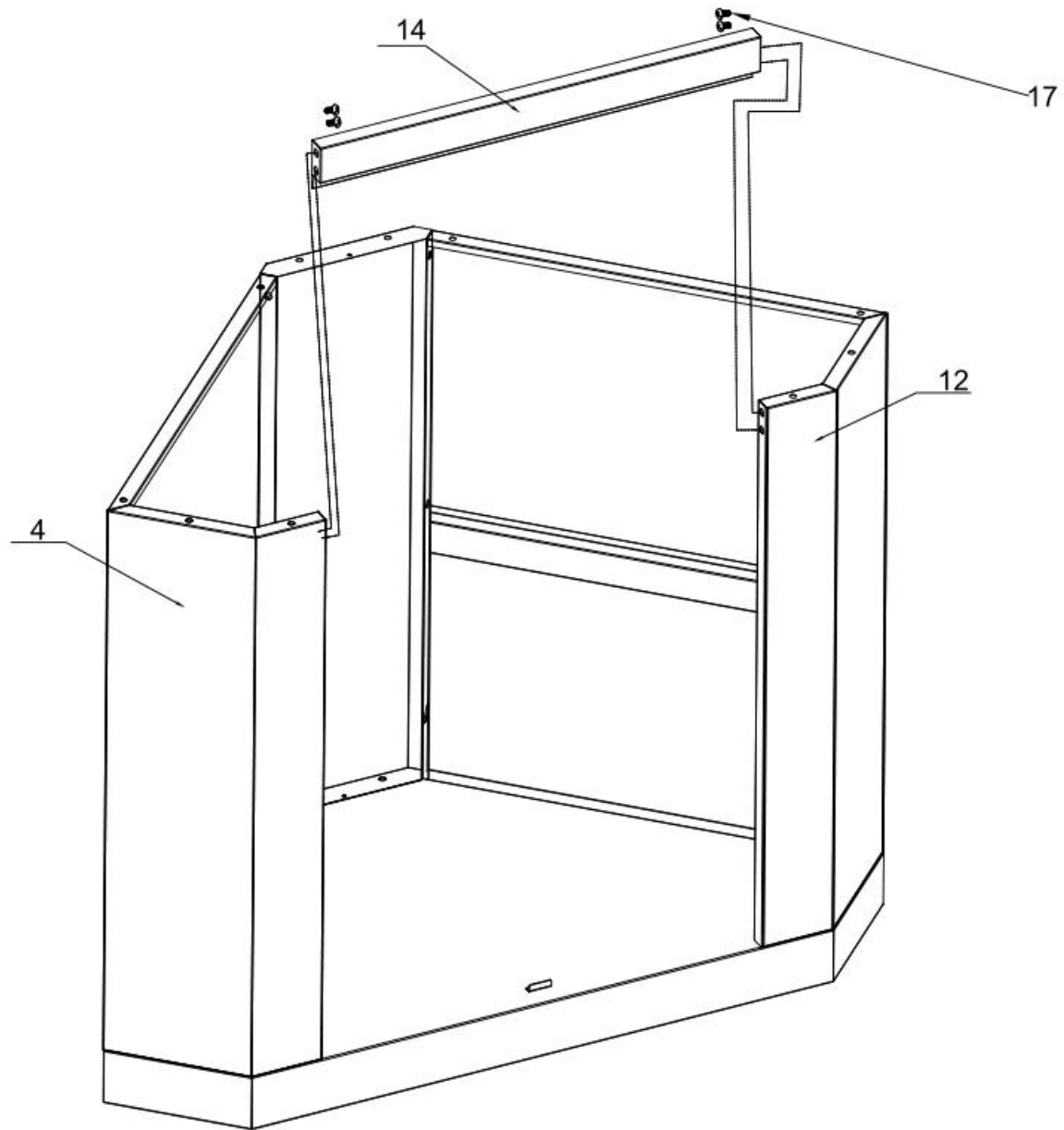

Step 6

1. Install 2 pcs Laminate welding holder (Part # 15) to Part # 4 and Part # 12, and then install Laminate welding assembly (Part # 2) on the top;
2. Use 16 pcs flat head screw (Part # 19) to install Door welding assembly (Part # 3) to Part # 4 and Part # 12.
3. Do not over-tighten all the screws until parts are lined up.

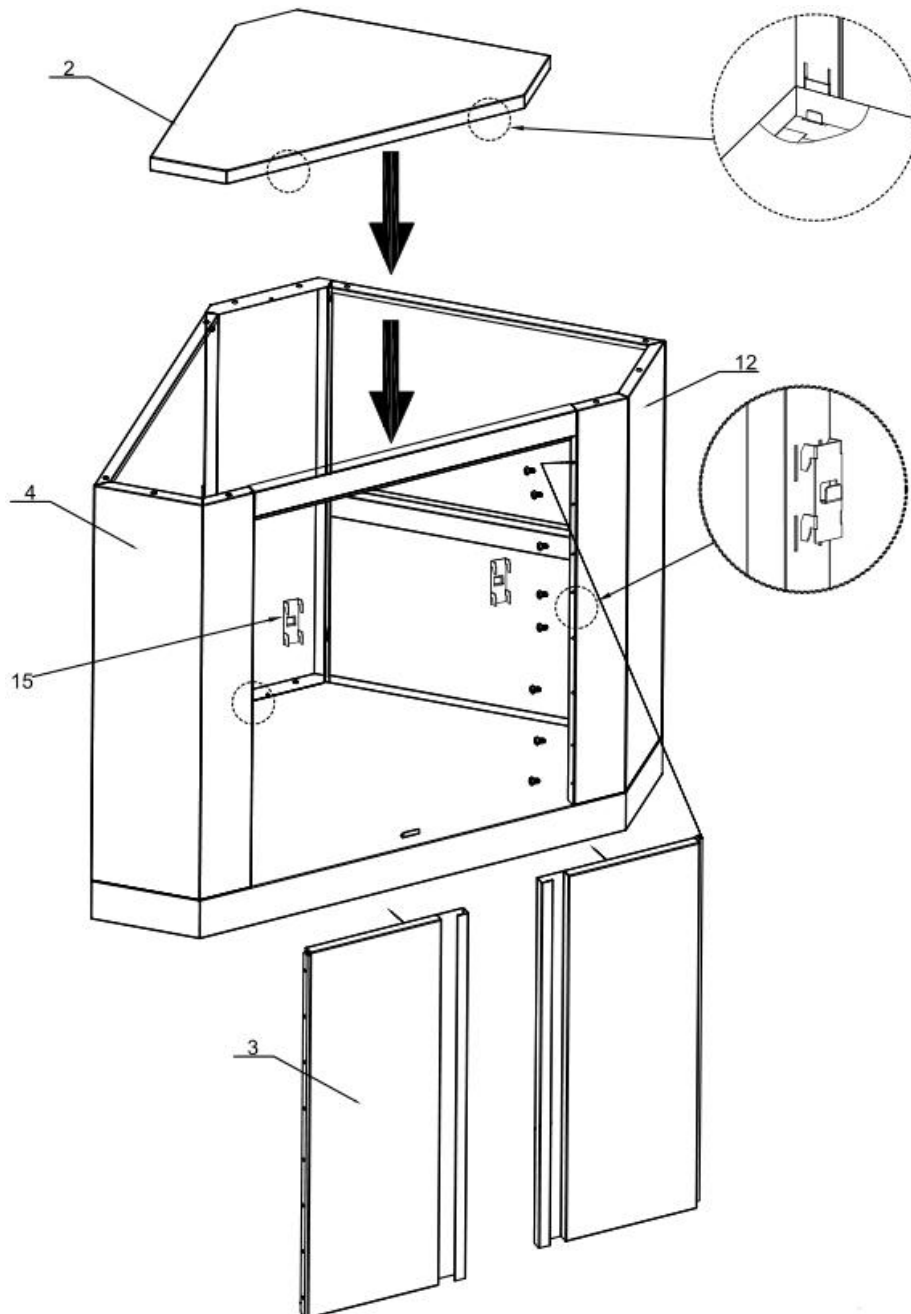

Step 7

1. Make sure Part # 2 is installed inside the cabinet first;
2. Use 10 pcs Part # 17 to Connect Countertop welding assembly (Part # 1) with Part # 4, # 5, # 6, # 11 and # 12. Do not over-tighten all the screws until parts are lined up.

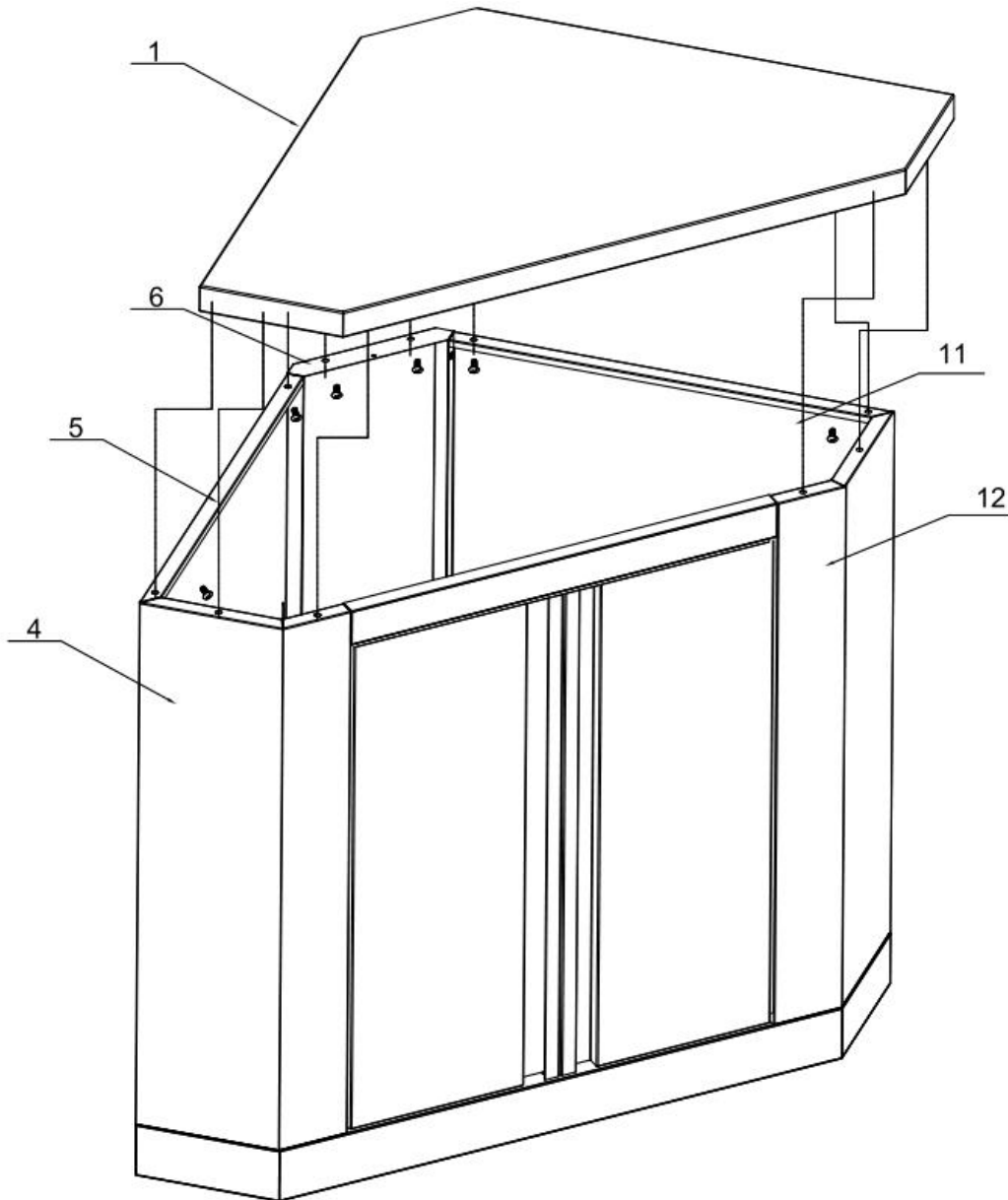

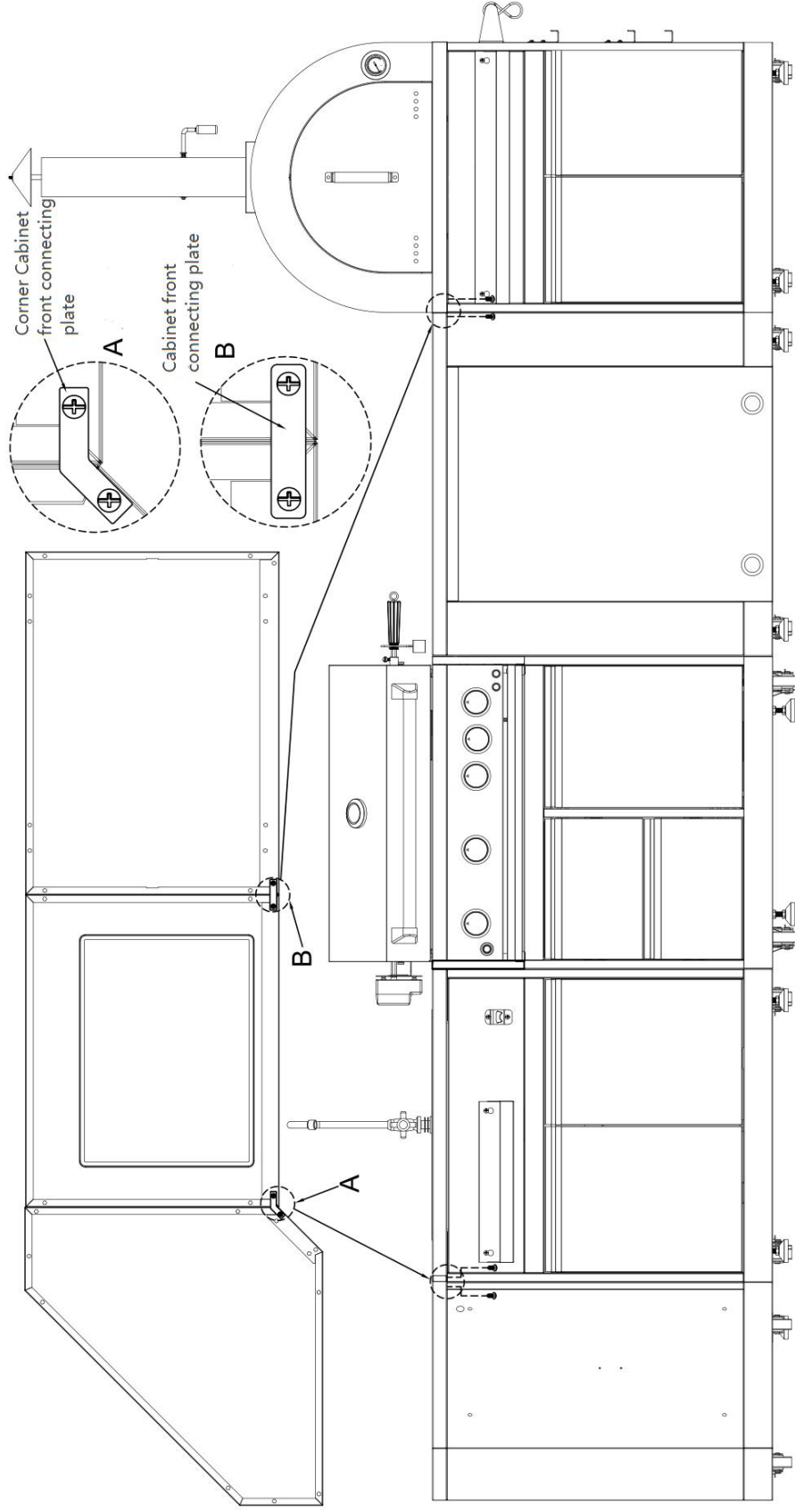

You Outdoor Cabinet could be connected with any other Our Door Cabinet models.

If you are having a Corner Cabinet and you would like to connect it to another cabinet, use corner cabinet connecting plate with 2 pcs ¼" screws (Part # 06.02.00093-000-A0) to connect both cabinets;

If you are having a Sink Cabinet, Appliance Cabinet or Pizza oven Cabinet, use cabinet connecting plate with 2 pcs ¼" screws to connect both cabinets.

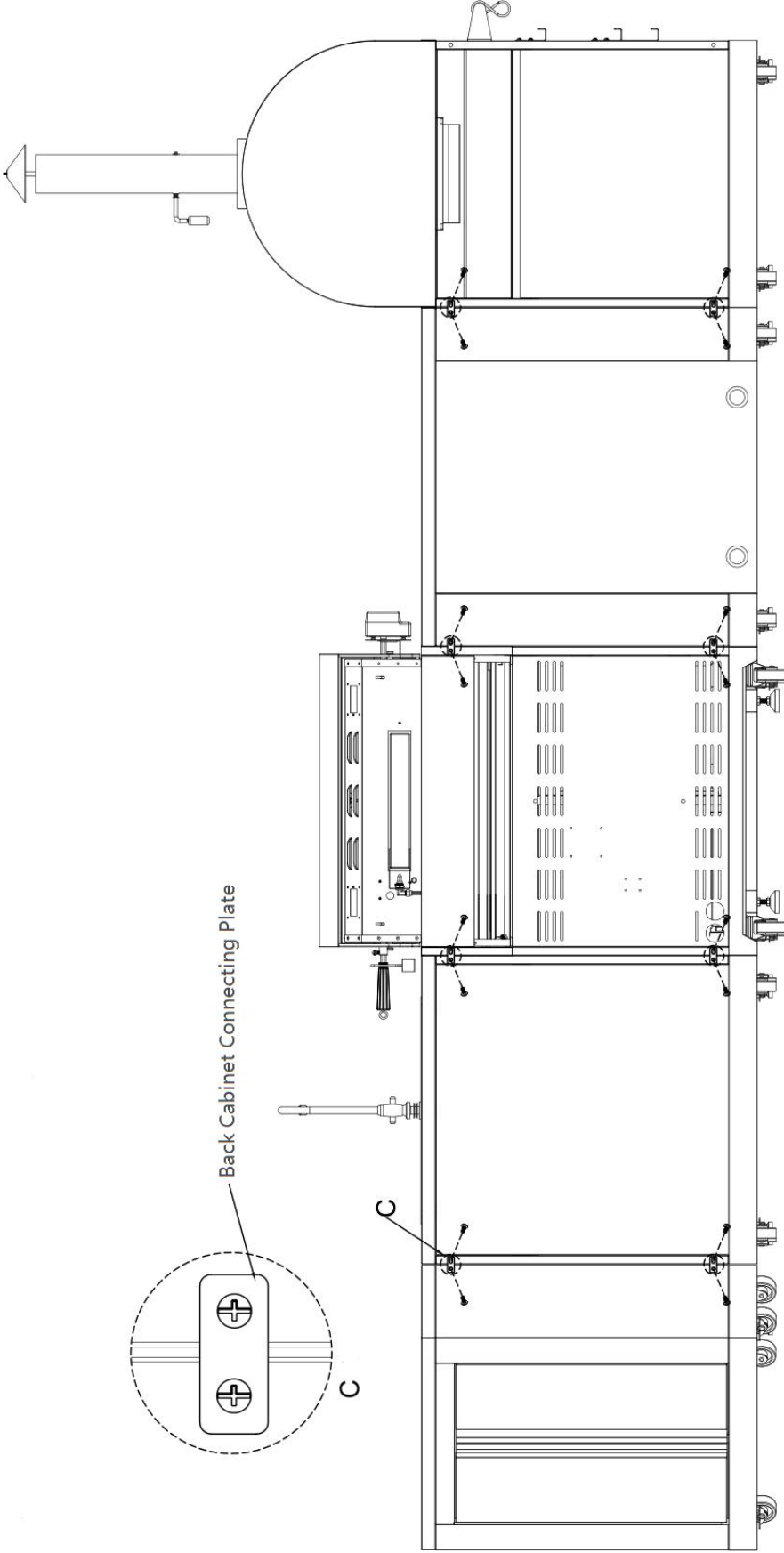

You Outdoor Cabinet could be connected with any other Our Door Cabinet models.
 For Back Panel Connections, use Back Cabinet connecting plate with 2 pcs 1/4" screws (Part # 06.02.00093-000-A0) to connect both Cabinets.