

# **Kräus<sup>®</sup>**

INSTALLATION MANUAL

## **Fireclay Workstation Farmhouse Kitchen Sink**

KFR4-33GWH

## **Congratulations on the purchase of your new Kraus® plumbing fixture!**

Please keep the box and packaging materials until your product is completely installed. If you have any questions, require technical assistance or have any problems with your product:

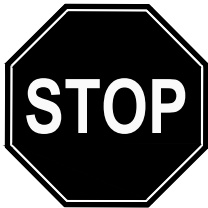

**DO NOT RETURN TO STORE**

**Please contact our Customer Service Team  
1-800-775-0703 / [customerservice@kraususa.com](mailto:customerservice@kraususa.com)**

Have the model number available and retain a copy of your receipt with purchase date for reference.

If for any reason this product does not meet your expectations, please be sure to repack this product in the original box and packaging material to avoid damage during transit.



### **Prior to Installation:**

- Inspect the sink prior to installation to make sure the sink has not been damaged during shipping.
- Observe all plumbing and building codes according to your state requirements.
- Additional floor and wall preparation may be required to avoid damaging the sink.
- Not recommended to be installed with laminate countertop.
- Note: Before installation, please check that the drain kit complies with ASME A112.18.2/CSA B125.2 and with CUPC certification.

**For technical assistance or replacement parts, please contact Kraus®**

**Customer Service and one of our representatives will be happy to help:**

Toll-Free: 800-775-0703 or [customerservice@kraususa.com](mailto:customerservice@kraususa.com)

The step-by-step guidelines in the installation instructions are a general reference for installing a Kraus Sink. Should there be any discrepancies, Kraus cannot be held liable. It is recommended to install all Kraus products by hiring a licensed professional.

### **Cleaning & Maintenance:**

---

Clean your sink on a regular basis with warm soapy water. Rinse the sink after using cleaning products. Wipe the sink surface with a soft cloth to remove any liquid residue. Do not cut food directly on the surface of the sink. Do not leave sharp objects on the surface of the sink for an extended period of time. Do not use abrasive cleaning products, sanding tools, steel wool or bleaching products as use of such products may affect product performance or void the warranty.

## Tools you will need:



**NOTE:** Specialized tools may be necessary to install Kraus® Fireclay sinks with countertop materials other than wood, marble or granite.

## Parts List

- Sink
- Strainer ST-4
- Cutting Board KCB-WS302SA

## Dimensions

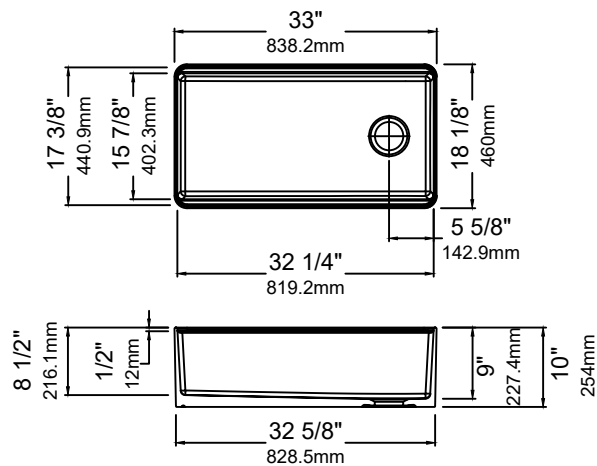

KFR4-33GWH  
33" x 18 1/8" x 10"

# 1. Measure & Build Supports

---

- Measure the actual height of apron
- Build supports on inside of cabinet based on sink measurements

## Installer Tip: Support options

- 1 1/4" Angle Irons
- (2) 2" x 4'
- 3/4" Plywood

**NOTE:** Due to the typical  $\pm 3\text{mm}$  side wall variance in manufacturing, it is recommended that you design / modify the sink cabinet to match your clients individual sink(s) need.

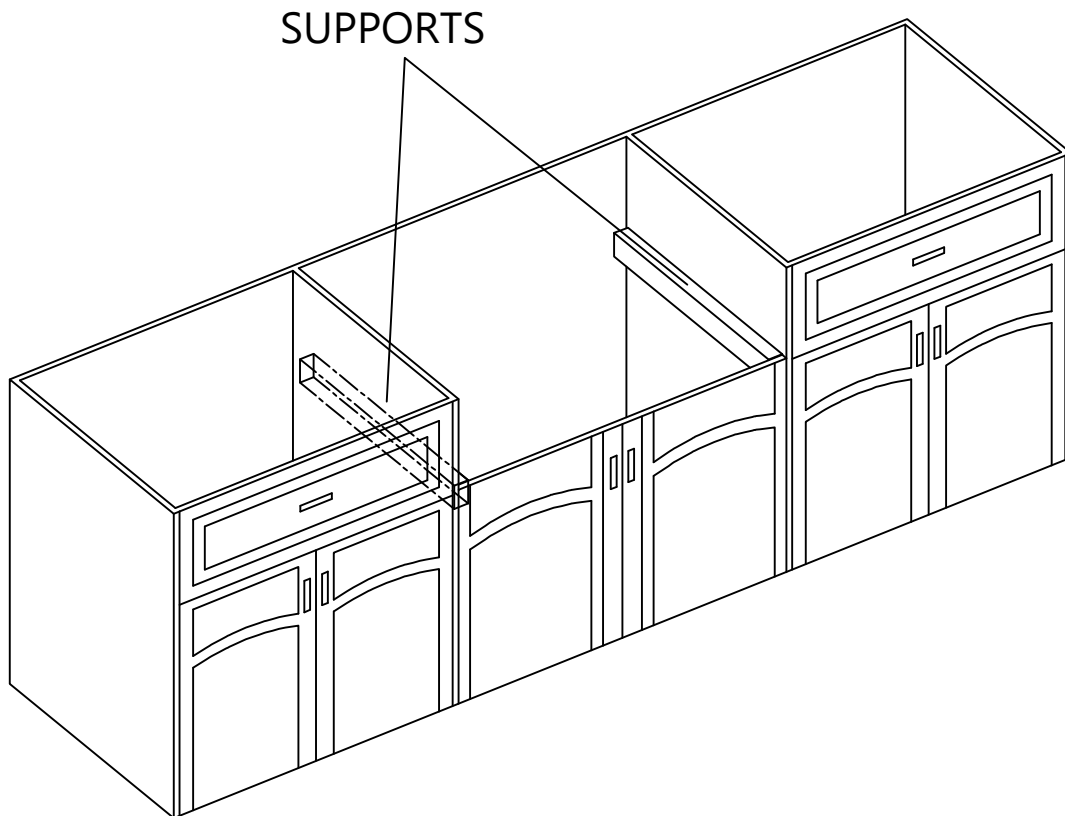

## 2. Cut Cabinet Front

---

- Measure height of apron front. Add  $\frac{1}{16}$ " to the dimension when you mark base cabinet front cutout. Use jigsaw to cut.

**!** **CAUTION** - To avoid the risk of personal injury, wear safety glasses and cut resistant gloves with non-slip grip when cutting.



**NOTE:** Please use the appropriate saw that best fits your countertop material.

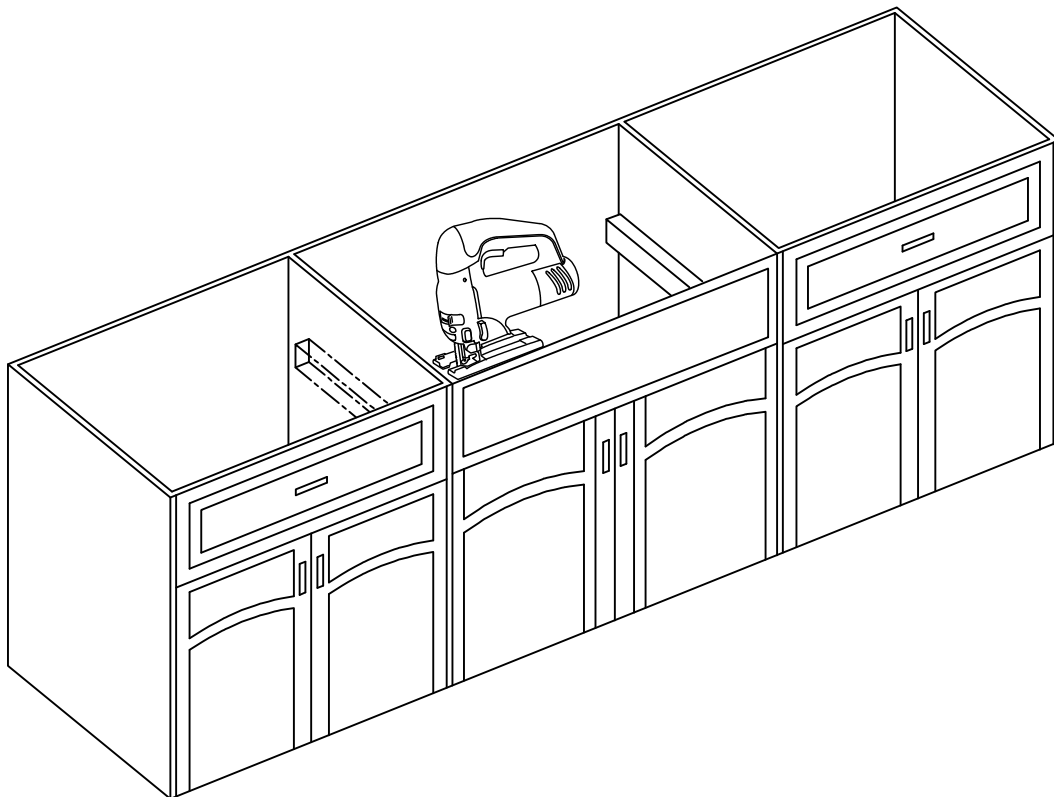

### 3. Install Sink

---

- Place sink in opening. The weight of sink should be sustained by the built supports.
- Make sure sink is leveled from front to back and side to side
- Uses silicone to fill in gaps where necessary

**NOTE:** This sink is reversible. Pick which apron you'd like facing forward before installing.

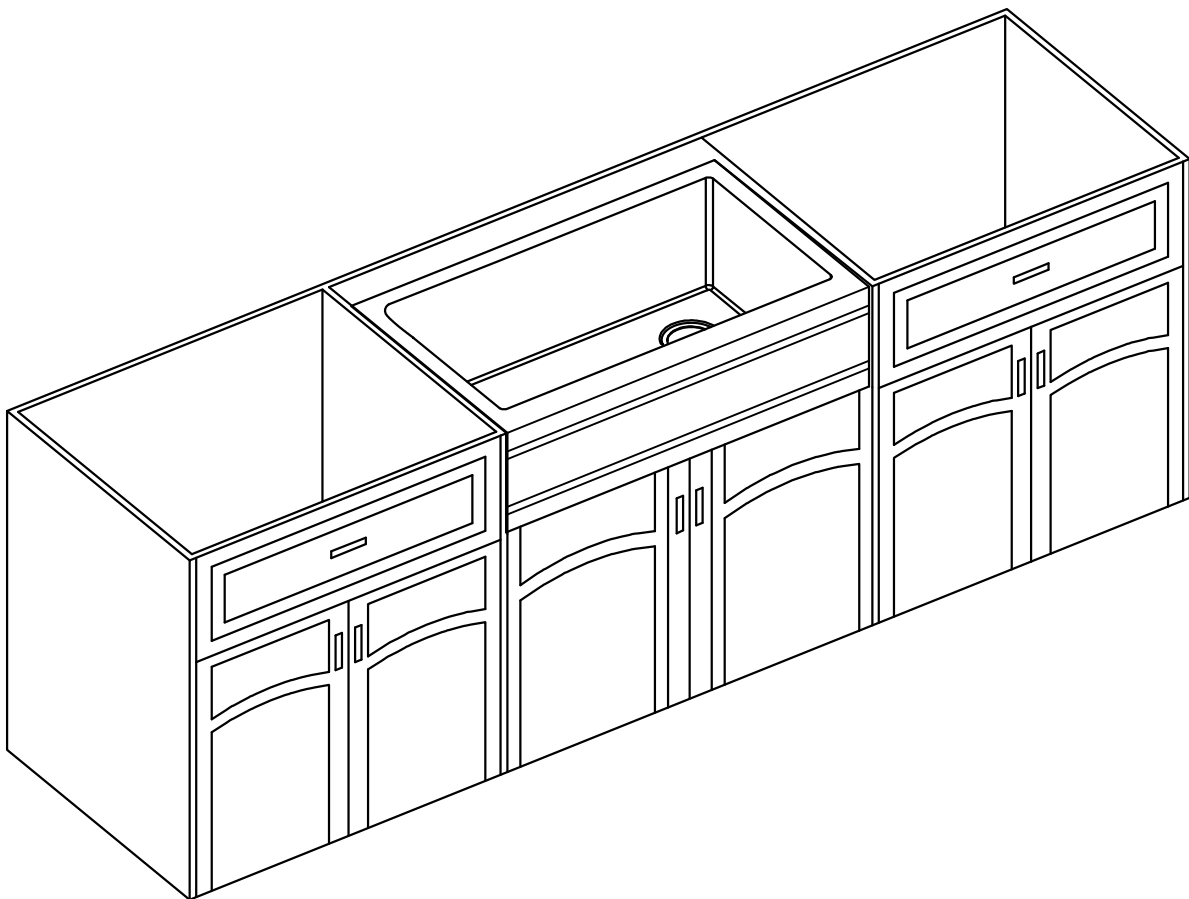

## 4. Cut Countertop

---

- Due to the custom nature of this type of installation, no cutout template is included.
- Kraus® recommends providing the cabinet maker with the actual sink to be installed prior to the cabinet fabrication.
- It is recommended that the sink be installed with an approximately 1/8" positive reveal. It is further recommended that the installer(s) discuss this with the customer and agree that this finished appearance is the desired effect.

**!** **CAUTION** - To avoid the risk of personal injury, wear safety glasses and cut resistant gloves with non-slip grip when cutting.

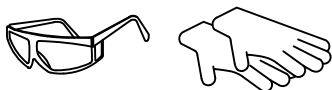

**NOTE:** Please use the appropriate saw that best fits your countertop material.

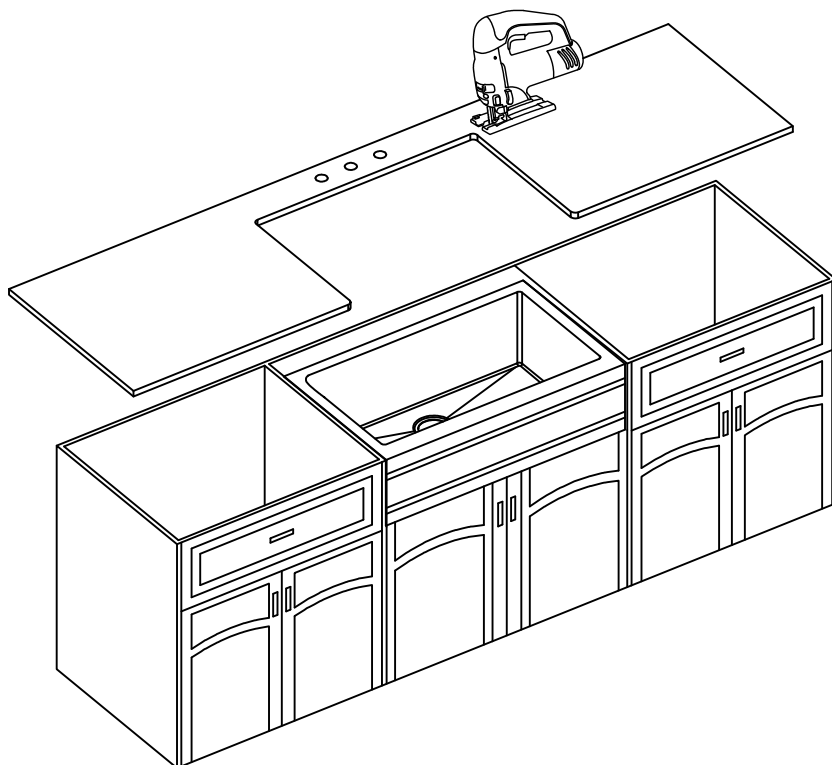



## 5. Install Countertop

---

- Use a bead of silicone (or preferred adhesive) around the rim of the sink. Check the alignment of the sink to the cutout in the countertop. Place countertop cutout hole over sink and press firmly.

**Installer Tip:** Use acetone or denatured alcohol to remove any excess sealant.

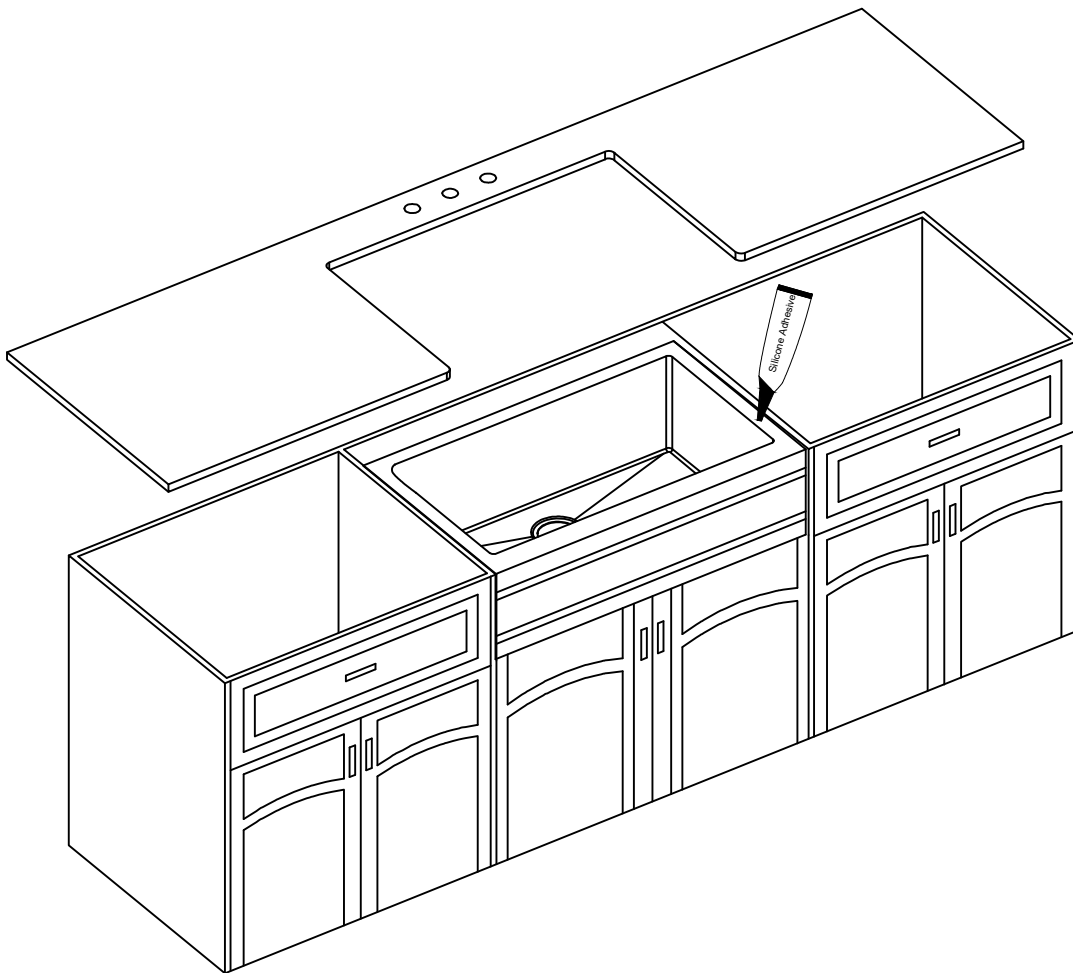

## 6. Installing Plumbing and Fixtures

---

- Connect drain, trap to drain and water supply connections to the faucet according to manufacturer's instruction.
- Run water into sink and check for leaks.

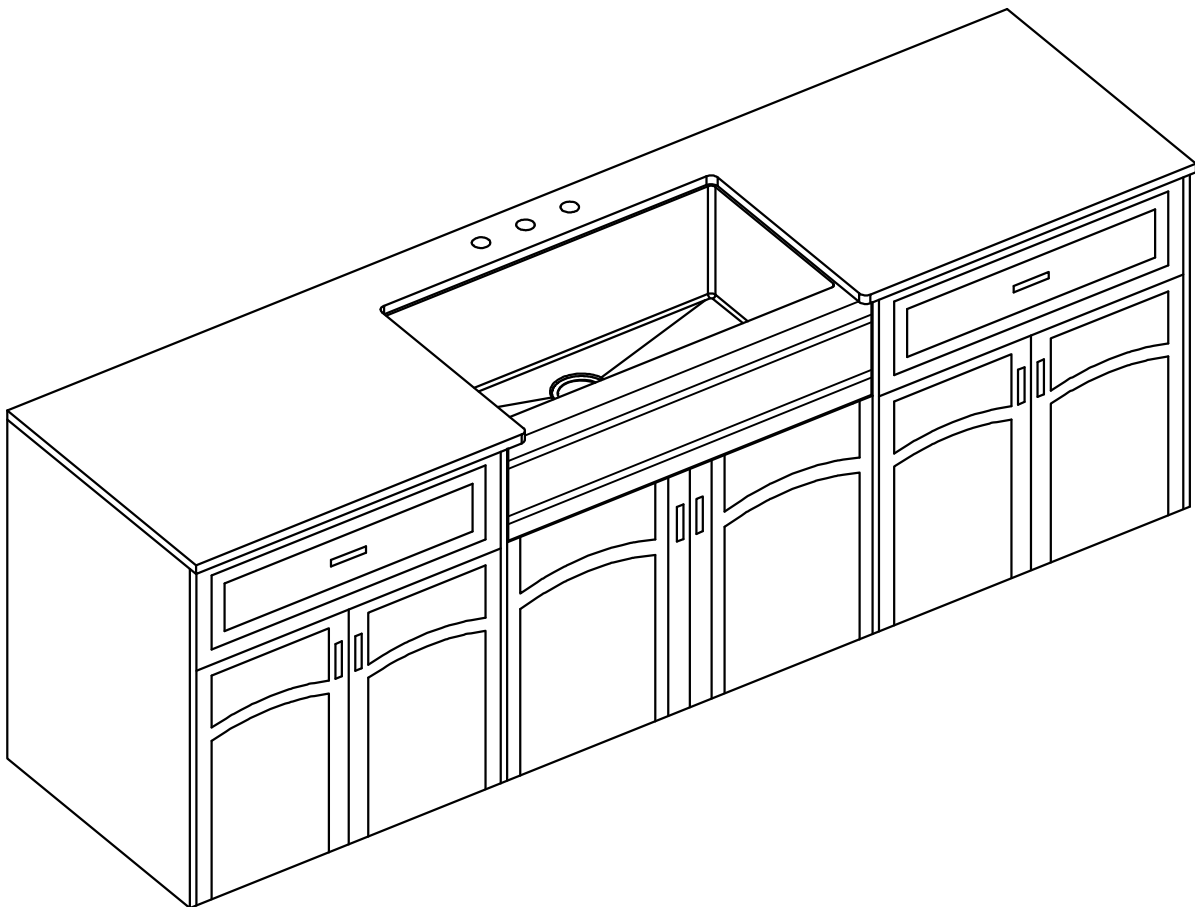

## Codes/Standards Applicable:



### Fireclay Kitchen Sink - Limited Warranty

Kraus® USA Plumbing, LLC ("Kraus") extends this warranty to the original purchaser for personal household use of the Fireclay Kitchen Sink when purchased from a Kraus authorized dealer and in the location of original installation. This warranty is non-transferable.

Kraus warrants the structure and finish of the Fireclay Kitchen Sink to be free from defects in material and workmanship under normal usage for a period of five (5) years from the date that the product is received by the original purchaser or their authorized representative (installation contractor, etc.).

### Commercial Warranty

Kraus USA Plumbing, LLC ("Kraus") warrants its Products for a period of one (1) year to commercial purchasers of Products used in industrial, commercial and business applications.

### What We Will Do

Any product reported to the authorized dealer or to Kraus that proves defective within the warranty period stated above will be repaired or replaced with a product of equal value at the option of Kraus. If repair or replacement is not practical, Kraus may elect to refund the purchase price in exchange for the return of the product. **These are your exclusive remedies.**

### Care and Cleaning Instructions

Certain cleaning products may cause damage to a Product's finish and use of the following cleaning products on the Product will void this warranty:

- Abrasive cleaners such as powders, bleach, ammonia, alcohol or chlorine
- Abrasive pads, steel wool or wire brushes

### Limitations

#### What is Not Covered

This warranty does not cover Products that were discontinued when purchased or display Products, whether such Products were purchased at discount outlets, unauthorized dealers, and/or sold on clearance. This warranty does not cover any free gifts included with purchase.

This warranty does not cover damage resulting from neglect, misuse (including use for an unintended application), abuse, carelessness, accident, hard water or mineral deposits, exposure to corrosive materials, improper maintenance, alteration of the Product, or failure to follow care, cleaning or installation instructions enclosed with your Product, and outdoor use. Kraus recommends that all Kraus Products be installed by a fully licensed and insured trade professional with experience in the installation of bathroom and/or kitchen manufactured goods.

## **How to Make a Warranty Claim**

In requesting warranty service, please be ready to provide:

1. Proof of purchase.
2. A description of the problem.

If you are a **CONSUMER PURCHASER**, please contact a Kraus® Customer Service Representative at:

Kraus USA Plumbing, LLC  
12 Harbor Park Drive  
Port Washington, NY 11050  
Toll-free 1-800-775-0703  
Customerservice@kraususa.com

If you are a **PLUMBING CONTRACTOR OR TRADE PROFESSIONAL**, please contact a Kraus Pro Representative at:

Kraus USA Plumbing, LLC  
12 Harbor Park Drive  
Port Washington, NY 11050  
516-801-8955  
Proservice@kraususa.com

If you are an **AUTHORIZED PARTNER**, please contact a Partner Support Representative at:

Kraus USA Plumbing, LLC  
12 Harbor Park Drive  
Port Washington, NY 11050  
516-801-8954  
Partnersupport@kraususa.com

This warranty gives you specific legal rights, and you may also have other rights which vary from state/province to state/province.

Shipping charges will be covered for the first (1) year of the warranted replacement part or product (HI, AK, and Puerto Rico shipping charges may apply). International shipping fees are not included.

### **Limitation on Duration of Implied Warranties**

Please note that some states/provinces (including Quebec) do not allow limitations on how long an implied warranty lasts, so the below limitations may not apply to you. TO THE MAXIMUM EXTENT PERMITTED BY APPLICABLE LAW, ANY IMPLIED WARRANTY, INCLUDING THE IMPLIED WARRANTIES OF MERCHANTABILITY AND OF FITNESS FOR A PARTICULAR PURPOSE, IS LIMITED TO THE STATUTORY PERIOD OR THE DURATION OF THIS WARRANTY, WHICHEVER IS SHORTER.

### **Limitation of Special, Incidental or Consequential Damages**

Please note that some states/provinces (including Quebec) do not allow the exclusion or limitation of special, incidental or consequential damages, so the below limitations and exclusions may not apply to you. TO THE MAXIMUM EXTENT PERMITTED BY APPLICABLE LAW, THIS WARRANTY DOES NOT COVER, AND KRAUS USA PLUMBING, LLC SHALL NOT BE LIABLE FOR, ANY SPECIAL, INCIDENTAL OR CONSEQUENTIAL DAMAGES (INCLUDING LABOR CHARGES TO REPAIR, REPLACE, INSTALL OR REMOVE THIS PRODUCT), WHETHER ARISING OUT OF BREACH OF ANY EXPRESS OR IMPLIED WARRANTY, BREACH OF CONTRACT, TORT, OR OTHERWISE.

**Download the Kraus Care & Maintenance Guide at:**  
<http://www.kraususa.com/maintenance>

# IMPORTANT

## Register Your Kraus Product

**Activate** Your Warranty

**Access** Premium Customer Support

**Get** Product Information

**REGISTER TODAY**

<http://www.kraususa.com/registration>



**Kräus**<sup>®</sup>  
www.kraususa.com