

Glass Door Merchandiser Refrigerator and Freezer (Swing and Sliding Door)

Kelvinator[®]
COMMERCIAL

Service, Installation and Care Manual

**Please read this manual completely before attempting to install or operate this equipment.
Notify carrier of damage! Inspect all components immediately.**



**IMPORTANT INFORMATION
READ BEFORE USE
PLEASE SAVE THESE INSTRUCTIONS!**

COMMERCIAL REFRIGERATOR SAFETY

Your safety and the safety of others are very important.

We have provided many important safety messages in this manual and on your appliance. Always read and obey all safety messages.

Our product instructions will be uploaded on our company official website.



This is the Safety Alert Symbol. This symbol alerts you to potential hazards that can kill or injure you and others. All safety messages will follow the Safety Alert Symbol and either the words "DANGER", "WARNING" or "CAUTION".



Danger means that failure to heed this safety statement may result in severe personal injury or death.



Warning means that failure to heed this safety statement may result in extensive product damage, serious personal injury, or death.



Caution means that failure to heed this safety statement may result in minor or moderate personal injury, or property or equipment damage.

All safety messages will alert you to what the potential hazard is, tell you how to reduce the chance of injury, and let you know what can happen if the instructions are not followed.

If the supply cord is damaged, it must be replaced by the manufacturer, its service agent or similarly qualified persons in order to avoid a hazard.

This appliance is not intended for use by persons (including children) with reduced physical, sensory or mental capabilities, or lack of experience and knowledge, unless they have been given supervision or instruction concerning use of the appliance by a person responsible for their safety.

Children should be supervised to ensure that they do not play with the appliance.

This appliance can be used by children aged from 8 years and above and persons with reduced physical sensory or mental capabilities or lack of experience and knowledge if they have been given supervision or instruction concerning use of the appliance in a safe way and understand the hazards involved. Children shall not play with the appliance. Cleaning and user maintenance shall not be made by children without supervision.

Keep the appliance and its cord out of reach of children less than 8 years.

Do not store explosive substances such as aerosol cans with a flammable propellant in this appliance.

Service and Installation Manual

The appliance use flammable insulation blowing gas C5H10, disposal of the appliance shall in accordance with the regulations of local authorities.

The key for appliance electric box should be safe kept by qualified persons in order to avoid a hazard



Warning; Risk of fire / flammable materials

WARNING: Keep ventilation openings, in the appliance enclosure or in the built-in structure, clear of obstruction.

WARNING: Do not use mechanical devices or other means to accelerate the defrosting process, other than those recommended by the manufacturer.

WARNING: Do not damage the refrigerant circuit.

WARNING: Do not use electrical appliances inside the food storage compartments of the appliance, unless they are of the type recommended by the manufacturer.

Handling, moving, and use of the refrigerator or freezer to avoid either damaging the refrigerant tubing, or increasing the risk of a leak

L'opération, le mouvement et l'utilisation du réfrigérant ou le congélateur doivent éviter les dommages du tuyau réfrigérant ou le risque de la fuite.

Caution – Risk of Fire or Explosion due to Flammable Refrigerant Used. Follow Handling Instructions Carefully in Compliance with U.S. Government Regulations.

Component parts shall be replaced with like components and that servicing shall be done by factory authorized service personnel, so as to minimize the risk of possible ignition due to incorrect parts or improper service.

Les pièces de rechange doivent être remplacées par les composants relatifs et les opérations doivent être faites par les professionnels afin de minimaliser le risque d'allumage à cause des parts incorrects ou des opérations impropres.

CAUTION – Risk Of Fire Or Explosion Due To Puncture Of Refrigerant Tubing; Follow Handling Instructions Carefully. Flammable Refrigerant Used

DANGER: Risk of child entrapment. Before you throw away your old refrigerator or freezer:

Take off the doors

Leave the shelves in place so that children may not easily climb inside

CONTENTS

RECEIVING & INSPECTING EQUIPMENT.....	4
SPECIFICATIONS.....	5
INSTALLATION.....	6
OPERATION.....	7
MAINTENANCE.....	8
STANDARD LABOR GUIDELINES.....	10
STANDARD WARRANTIES.....	11
WIRING DIAGRAM.....	12

All rights reserved. Reproduction without written permission is prohibited.

SERIAL NUMBER INFORMATION

The serial number of all self-contained refrigerators and freezers is located inside the unit on the left hand side near the top on the wall.

Always have the serial number of your unit available when calling for parts or service.

This manual covers standard units only. If you have a custom unit, consult the customer service department at the number listed in the back cover.

RECEIVING AND INSPECTING THE EQUIPMENT

Even though most equipment is shipped crated, care should be taken during unloading so the equipment is not damaged while being moved into the building.

1. Visually inspect the exterior of the package and skid or container. Any damage should be noted and reported to the delivering carrier immediately.
2. If damaged, open and inspect the contents with the carrier.
3. In the event that the exterior is not damaged, yet upon opening, there is concealed damage to the equipment notify the carrier. Notification should be made verbally as well as in written form.
4. Request an inspection by the shipping company of the damaged equipment. This should be done within 10 days from receipt of the equipment.
5. Be certain to check the compressor compartment housing and visually inspect the refrigeration package. Be sure lines are secure and base is still intact.
6. Freight carriers can supply the necessary damage forms upon request.
7. Retain all crating material until an inspection has been made or waived.

SPECIFICATION

ICE CUBE MERCHANDISERS						
MODEL#	V/Hz/Ph	AMPS	STORAGE CAPACITY Cu-ft	CHARGE OZ	SHIP WEIGHT LBS	NEMA PLUG
KCHGICM23FB	115/60/1	8.0	23	3.88	353	5-15P
KCHGICM49FB	115/60/1	9.0	48	5.29	368	5-20P

INSTALLATION

Location

Units represented in this manual are intended for indoor use only. Be sure the location chosen has a floor strong enough to support the total weight of the cabinet and contents. A fully loaded unit can weigh as much as 1500 pounds. Reinforce the floor as necessary to provide for maximum loading. For the most efficient refrigeration, be sure to provide good air circulation inside and out.

Inside cabinet:

Do not pack refrigerator so full that air cannot circulate. The refrigerated air is discharged at the top rear of the unit. It is important to allow for proper air flow from the top rear to the bottom of the unit. Obstructions to this air flow can cause evaporator coil freeze ups and loss of temperature or overflow of water from the evaporator drain pan. The shelves have a rear turn up on them to prevent this. However, bags and other items can still be located to the far rear of the cabinet. Air is brought into the evaporator coil with fans mounted to the front of the coil. Prevent obstruction by locating large boxes and tall stacks of product to the bottom of the cabinet.

Outside cabinet:

Be sure that the unit has access to ample air. Avoid hot corners and locations near stoves and ovens. It is recommended that the unit be installed no closer than 2" from any wall with at least 12" of clear space above the unit. Should it become necessary to lay the unit on its side or back for any reason, allow at least 24 hours before start-up so as to allow compressor oil to flow back to the sump. Failure to meet this requirement can cause compressor failure and unit damage.

Leveling

A level cabinet looks better and will perform better because the doors will line up with the frames properly, the cabinet will not be subject to undue strain and the contents of the cabinet will not move around on the shelves. Use a level to make sure the unit is level from front to back and side to side. Units supplied with legs will have adjustable bullet feet to make the necessary adjustments. If the unit is supplied with casters, no adjustments are available. Ensure the floor where the unit is to be located is level.

Stabilizing

Models are supplied on casters for your convenience, ease of cleaning underneath and for mobility. It is very important, however, that the cabinet be installed in a stable condition with the front wheels locked while in use.



NOTE

Standard warranties will be voided due to improper installation procedures.

Electrical connection

Refer to the amperage data on page 3, the serial tag, your local code or the National Electrical Code to be sure the unit is connected to the proper power source. A protected circuit of the correct voltage and amperage must be run for connection of the line cord, or permanent connection to the unit.



DANGER

The ON/OFF switch must be turned to OFF and the unit disconnected from the power source whenever performing service, maintenance functions or cleaning the refrigerated area.

OPERATION



CAUTION

Do not throw items into the storage area. Failure to heed these recommendations could result in damage to the interior of the cabinet.

Refrigeration cycle

Refrigerators: Every 6 hours, the unit will turn off to let the evaporator coil clear up the ice. The controller now displays the defrost symbol. When the coil temperature reaches 41°F or after 20 minutes of defrost, the unit will turn on again. The factory setting of the temperature range is 34 to 38°F.

Freezers: During the refrigeration cycle, the controller supplies power to the condensing unit and evaporator fan motors. The evaporator fan will run at any time when the evaporator coil temperature is below 54°F and it will cycle off during the defrost period. Every 6 hours, the unit will turn off and the defrost heater will work to clear up the ice. The controller now displays the defrost symbol. When the coil temperature reaches 45°F or after 20 minutes of defrost, the unit will turn on again.

1. Anti-Condensation heaters on the door frames work in conjunction with the compressor.
2. The factory setting of the temperature range is -7 to -3°F

On/Off Switch:

An on/off switch is located on the front of the bottom panel. When the unit is on, the switch will glow green.

Light Switch:

A light switch is located next to the on/off switch on the front of the bottom panel.

SOLID-STATE THERMOSTAT DESCRIPTIONS

1. FRONT PANEL COMMANDS

1.1 KEY FUNCTION

SET: To display target set point; in programming mode, it selects a parameter or confirms an operation.

(DEF) To start a manual defrost

(UP) To view last alarm occurrence; in programming mode, it browses the parameter codes or increases the display value

(DOWN) To view last alarm occurrence; in programming mode, it browses the parameter codes or decreases the display value

KEY COMBINATION

+ To lock & unlock the keyboard





SET + To enter in programming mode

SET + To return to the room temperature display

To switch the instrument off.



1.2 Function of LEDS



LED	MODE	SIGNIFICATO
	On	Compressor enabled
	Flashing	Anti-short cycle delay enabled (AC parameter)
	On	Defrost in progress
	Flashing	Dripping in progress
	On	Fans output enabled
	Flashing	Fans delay after defrost
	On	Measurement unit
	Flashing	Programming mode
	On	Measurement unit
	Flashing	Programming mode

2. MAIN FUNCTIONS

2.1 HOW TO SEE THE SETPOINT

1. Push and immediately release the **SET** key: the display will show the set point value.
2. Push and immediately release the **SET** key or wait for 5 seconds to display the sensor value again.

2.2 HOW TO CHANGE THE SETPOINT

1. Hold the **SET** key for more than 2 seconds to change the set point value.
2. The value of the set point will be displayed and the  LED starts blinking.
3. To change the set value push the  or  key within 10s.
4. To set a new point value, push the SET key again or wait 10s.





2.3 HOW TO START A MANUAL DEFFROST

Push the  key for more than 2 seconds and a manual defrost will start





2.4 HOW TO LOCK THE KEYBOARD

1. Hold the  and  keys for more than 3s.
2. The "POF" message will be displayed and the keyboard will be locked. At this point, it will be possible only to see the set point or the MAX or Min temperature stored.
3. If a key is pressed more than 3s, the "POF" message will be displayed.





2.5 HOW TO UNLOCK THE KEYBOARD

Hold the  and  keys together for more than 3s till the "POF" message is displayed.

3. ALARM SIGNALS

HOW TO SEE THE ALARM AND RESET THE RECORDED ALARM

1. Push the  or  key to display alarm signals.
2. When the signal is displayed, hold the **SET** key until the "rst" message is displayed, and push the **SET** key again. The "rst" message will start blinking and the normal temperature will be displayed again.

Message	Cause	Outputs
"P1"	Room probe failure	Compressor output according to par. "Con" and "COF"
"P2"	Evaporator probe failure	Defrost end is timed
"HA"	Maximum temperature alarm	Outputs unchanged.
"LA"	Minimum temperature alarm	Outputs unchanged.
"dA"	Door open	Compressor and fans restarts
"EA"	External alarm	Output unchanged.
"CA"	Serious external alarm (i1F=bAL)	All outputs OFF.
"CA"	Pressure switch alarm (i1F=PAL)	All outputs OFF

MAINTENANCE



The power must be turned OFF and the unit disconnected from the power source whenever performing service, maintenance functions or cleaning the refrigerated area.

Refrigerators and Freezers

The interior and exterior can be cleaned using soap and warm water. If this isn't sufficient, try ammonia and water or a nonabrasive liquid cleaner. When cleaning the exterior, always rub with the "grain" of the stainless steel to avoid marring the finish.

Do not use an abrasive cleaner because it will scratch the stainless steel and plastic and can damage the breaker strips and gaskets.

Cleaning the Condenser Coil

The condenser coil requires regular cleaning. Recommended cleaning is every 90 days. In some instances, you may find that there is a large amount of debris and dust or grease accumulated prior to the 90 day time frame. In these cases the condenser coil should be cleaned every 30 days.

If the build up on the coil consists of only light dust and debris, the condenser coil can be cleaned with a simple brush. Heavier dust build-up may require a vacuum or even compressed air to blow through the condenser coil.

If heavy grease is present, there are de-greasing agents available for refrigeration use and specifically for the condenser coils. The condenser coil may require a spray with the de-greasing agent and then blown through with compressed air.

Failure to maintain a clean condenser coil can initially cause high temperatures and excessive run times. Continuous operation with dirty or clogged condenser coils can result in compressor failures. Neglecting the condenser coil cleaning procedures will void any warranties associated with the compressor or cost to replace the compressor.



Never use a high pressure water wash for this cleaning procedure as water can damage the electrical components located near or at the condenser coil.

In order to maintain proper refrigeration performance, the condenser fins must be cleaned of dust, dirt and grease regularly. It is recommended that this be done at least every three months. If conditions are such that the condenser is totally blocked in three months, the frequency of cleaning should be increased. Clean the condenser with a vacuum cleaner or stiff brush. If extremely dirty, a commercial-grade condenser cleaner may be required.





Stainless Steel Care and Cleaning

To prevent discoloration of rust on stainless steel several important steps need to be taken. First, we need to understand the properties of stainless steel. Stainless steel contains 70-80% iron which will rust. It also contains 12-30% chromium which forms an invisible passive film over the steels surface which acts as a shield against corrosion. As long as the protective layer is intact, the metal is still stainless. If the film is broken or contaminated, outside elements can begin to breakdown the steel and begin to form rust of discoloration. Proper cleaning of stainless steel requires soft cloths or plastic scouring pads,



NEVER USE STEEL PADS, WIRE BRUSHES OR SCRAPERS!

1.2 Function of LEDS



LED	MODE	SIGNIFICATO
	On	Compressor enabled
	Flashing	Anti-short cycle delay enabled (AC parameter)
	On	Defrost in progress
	Flashing	Dripping in progress
	On	Fans output enabled
	Flashing	Fans delay after defrost
	On	Measurement unit
	Flashing	Programming mode
	On	Measurement unit
	Flashing	Programming mode

2. MAIN FUNCTIONS

2.1 HOW TO SEE THE SETPOINT

1. Push and immediately release the **SET** key: the display will show the set point value.
2. Push and immediately release the **SET** key or wait for 5 seconds to display the sensor value again.

2.2 HOW TO CHANGE THE SETPOINT

1. Hold the **SET** key for more than 2 seconds to change the set point value.
2. The value of the set point will be displayed and the  LED starts blinking.
3. To change the set value push the  or  key within 10s.
4. To set a new point value, push the SET key again or wait 10s.





2.3 HOW TO START A MANUAL DEFFROST

Push the  key for more than 2 seconds and a manual defrost will start



2.4 HOW TO LOCK THE KEYBOARD

1. Hold the  and  keys for more than 3s.
2. The "POF" message will be displayed and the keyboard will be locked. At this point, it will be possible only to see the set point or the MAX or Min temperature stored.
3. If a key is pressed more than 3s, the "POF" message will be displayed.





2.5 HOW TO UNLOCK THE KEYBOARD

Hold the  and  keys together for more than 3s till the "POF" message is displayed.

3. ALARM SIGNALS

HOW TO SEE THE ALARM AND RESET THE RECORDED ALARM

1. Push the  or  key to display alarm signals.
2. When the signal is displayed, hold the **SET** key until the "rst" message is displayed, and push the **SET** key again. The "rst" message will start blinking and the normal temperature will be displayed again.

Message	Cause	Outputs
"P1"	Room probe failure	Compressor output according to par. "Con" and "COF"
"P2"	Evaporator probe failure	Defrost end is timed
"HA"	Maximum temperature alarm	Outputs unchanged.
"LA"	Minimum temperature alarm	Outputs unchanged.
"dA"	Door open	Compressor and fans restarts
"EA"	External alarm	Output unchanged.
"CA"	Serious external alarm (i1F=bAL)	All outputs OFF.
"CA"	Pressure switch alarm (i1F=PAL)	All outputs OFF

MAINTENANCE

Swing Door Replacement and Adjustment

1. Open the bottom panel and hold the door. Then loosen the bottom hinge screw and take off the old door.
2. Prepare new door; insert top pin into top hinge, get one bottom hinge to hold the door with the bottom pin.
Fasten bottom hinge securely to the door frame with three screws.
3. Allow the door to freely swing, making sure it swings closed by itself with no restriction.
4. Plug the unit in and make sure the lock works well.
5. If not, adjust the door height by adding the plastic spacer/washer provided with the bottom hinge pin.

Sliding Door Replacement and Adjustment

1. Take off the hook of the counterweight of door from the top of the door.
2. Hold the door up until the bottom edge is over the channel. Move the door out across the channel and lay the door down.
3. Prepare new door; hold the door insert into top channel until the bottom edge is over the bottom channel.
Slide the bottom of the door across the channel wall and place it into the channel.

Remove the bottom panel

Loosen and remove the top screws, slide the panel up and out

Light Bulb Replacement

1. Upper light bulb replacement: Loosen the screws in the bottom of the top panel and swing the panel up until the light bulb is exposed. Light bulb can then be changed.
2. LED light bulb replacement: Take the cover off to replace the LED light bulb.

WIRING DIAGRAM

MODEL: IB23

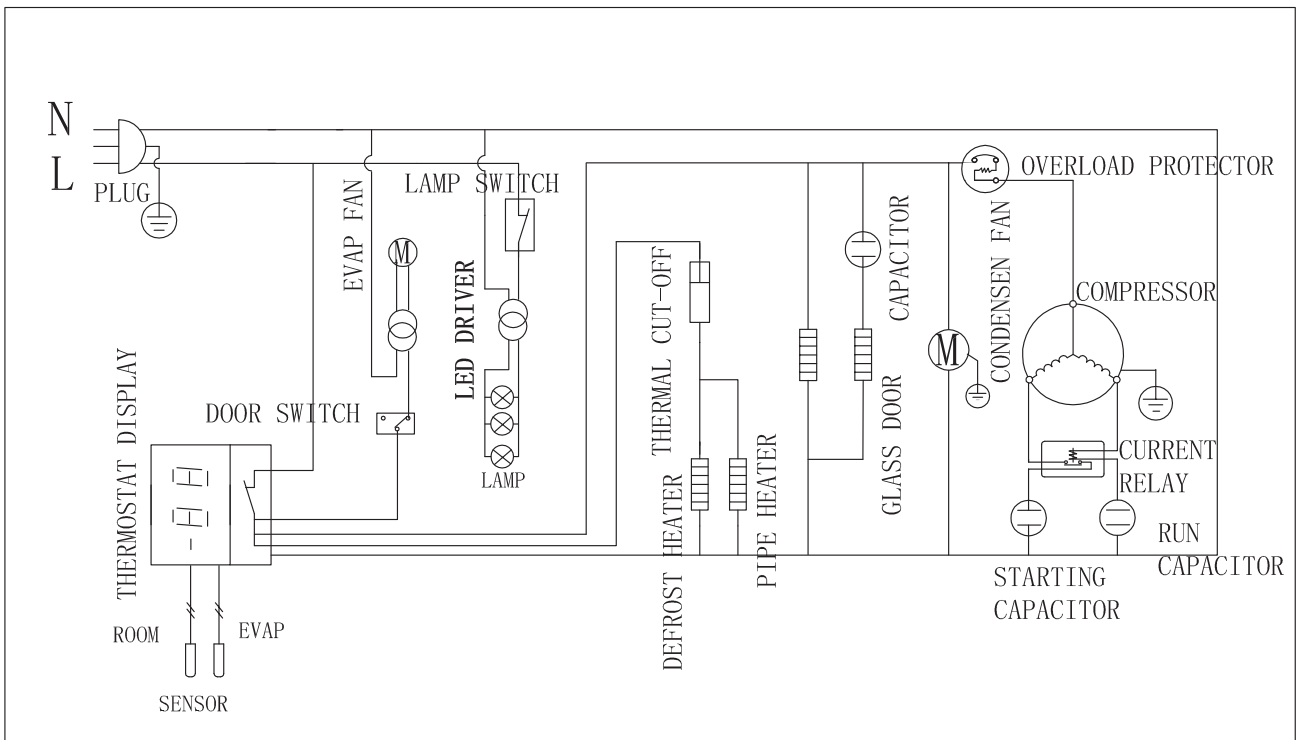

MODEL: IB48

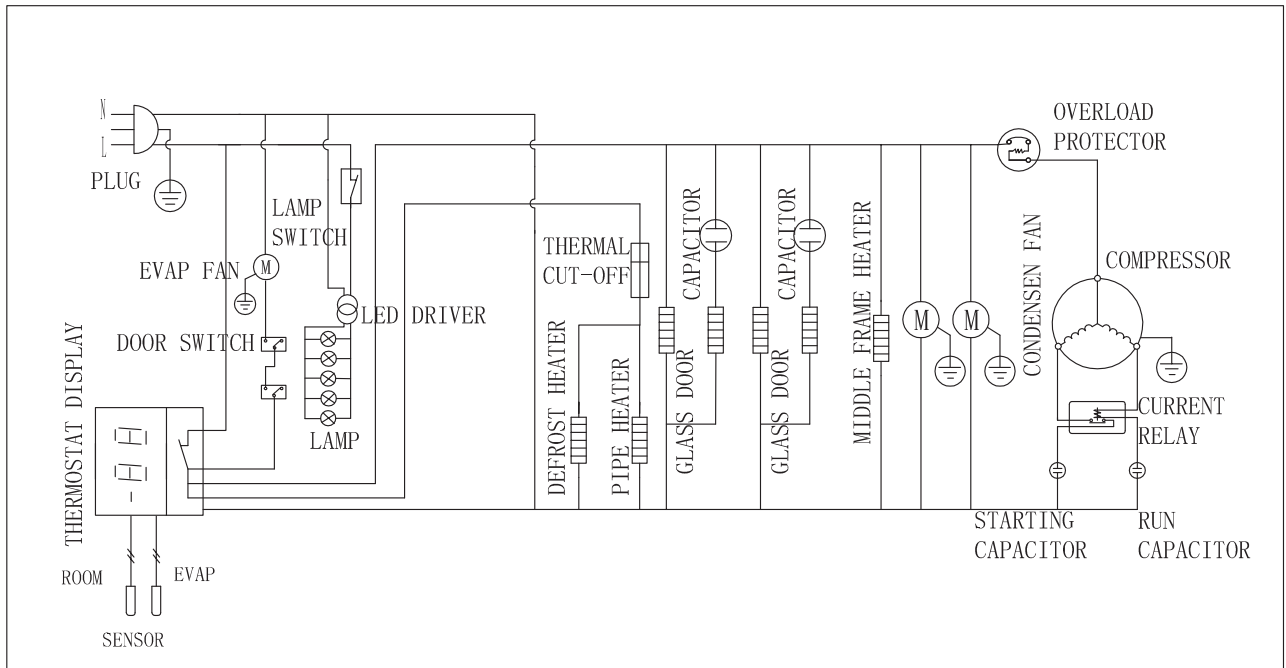

WIRING DIAGRAM

MODEL:IB23



WIRING DIAGRAM

MODEL: IB48

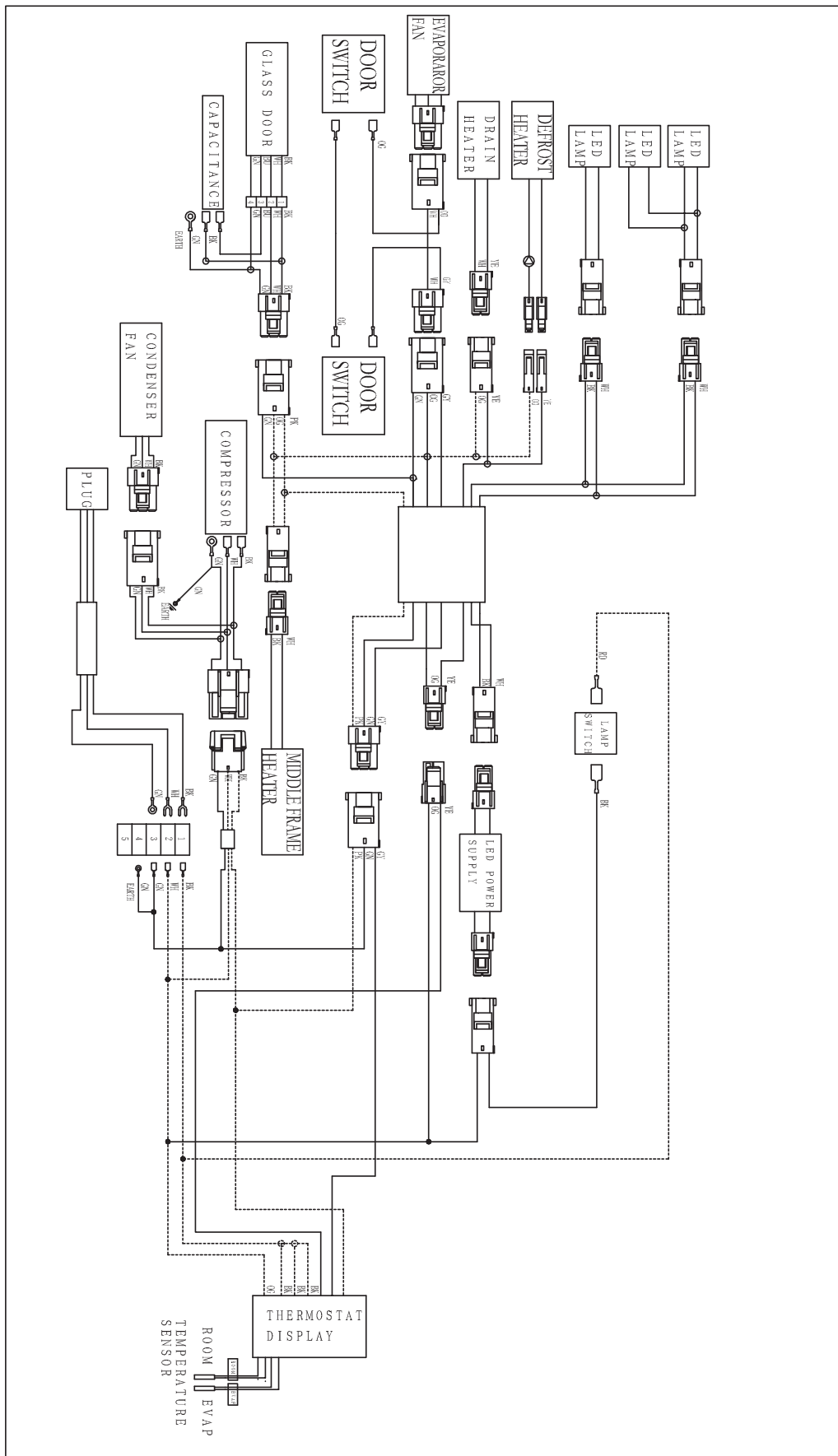

Kelvinator Commercial Appliance Warranty Information

Your appliance is covered by a **three (3) year limited warranty**. For three (3) years from your original date of purchase, Electrolux will pay all costs, except as set forth below, for repairing or replacing any parts of this appliance that prove to be defective in materials or workmanship when such appliance is installed, used, and maintained in accordance with the provided instructions. For appliances that are manufactured with a compressor, an additional two (2) year part warranty is provided for the compressor only.

Exclusions

This warranty does not cover the following:

1. Products where the original serial number has been removed, altered or cannot be readily determined.
2. Normal wear and tear and gradual deterioration.
3. Product that has been transferred from its original owner to another party or moved outside the USA or Canada.
4. Rust on the interior or exterior of the unit.
5. Products purchased "as-is".
6. Food loss due to any refrigerator or freezer failures.
7. Damage caused at any time during shipment.
8. Service calls which do not involve malfunction or defects in materials or workmanship, or for appliances used other than in accordance with the provided instructions.
9. Service calls to correct the installation of your appliance or to instruct you how to use your appliance.
10. Expenses for making the appliance accessible for servicing, such as removal of trim, cupboards, shelves, etc., which are not a part of the appliance when it is shipped from the factory.
11. Service calls to replace appliance light bulbs, air filters, water filters, and other consumables, or knobs, handles, and other cosmetic parts.
12. Surcharges including, but not limited to, any after hours, weekend, or holiday service calls, tolls, ferry trip charges, or mileage expense for service calls to remote areas, including the state of Alaska.
13. Damages to the finish of the appliance and/or the appliance location that are incurred during installation, including but not limited to floors, cabinets, walls, etc.
14. Damages caused by: services performed by unauthorized service companies; use of parts other than genuine Electrolux parts or parts obtained from persons other than authorized service companies; or external causes such as abuse, misuse, inadequate power supply, accidents, fires, or acts of God.
15. For appliances operated by a concessionaire or vendor in a trailer or other motorized vehicle, or at varying locations, your appliance is covered by a one (1) year, limited parts and labor warranty. For appliances that are manufactured with a compressor, an additional four (4) year part warranty is provided for the compressor only.

DISCLAIMER OF IMPLIED WARRANTIES; LIMITATION OF REMEDIES

CUSTOMER'S SOLE AND EXCLUSIVE REMEDY UNDER THIS LIMITED WARRANTY SHALL BE PRODUCT REPAIR OR REPLACEMENT AS PROVIDED HEREIN. CLAIMS BASED ON IMPLIED WARRANTIES, INCLUDING WARRANTIES OF MERCHANTABILITY OR FITNESS FOR A PARTICULAR PURPOSE, ARE LIMITED TO ONE (1) YEAR OR THE SHORTEST PERIOD ALLOWED BY LAW, BUT NOT LESS THAN ONE (1) YEAR. ELECTROLUX SHALL NOT BE LIABLE FOR CONSEQUENTIAL OR INCIDENTAL DAMAGES SUCH AS PROPERTY DAMAGE AND INCIDENTAL EXPENSES RESULTING FROM ANY BREACH OF THIS WRITTEN LIMITED WARRANTY OR ANY IMPLIED WARRANTY. SOME STATES AND PROVINCES DO NOT ALLOW THE EXCLUSION OR LIMITATION OF INCIDENTAL OR CONSEQUENTIAL DAMAGES, OR LIMITATIONS ON THE DURATION OF IMPLIED WARRANTIES, SO THESE LIMITATIONS OR EXCLUSIONS MAY NOT APPLY TO YOU. THIS WRITTEN WARRANTY GIVES YOU SPECIFIC LEGAL RIGHTS. YOU MAY ALSO HAVE OTHER RIGHTS THAT VARY FROM STATE TO STATE.

If You Need Service In order to obtain service the unit must first be registered at KelvinatorCommercial.com. Once registered please call 866-738-1640 for assistance.

This warranty only applies in the USA and Canada and is warranted by **Electrolux Professional Group SPA**.

Electrolux authorizes no person to change or add to any obligations under this warranty. Obligations for service and parts under this warranty must be performed by Electrolux or an authorized service company. Product features or specifications as described or illustrated are subject to change without notice.

(December 2018)

1.866.738.1640

Electrolux Professional
Group North America
10200 David Taylor Drive
Charlotte, NC 28262



Información sobre la garantía del electrodoméstico de Kelvinator Commercial

Su electrodoméstico cuenta con **tres (3) años de garantía limitada**. Por tres (3) años desde la fecha original de compra, Electrolux pagará todos los costos de reparación o el reemplazo de cualquier pieza de este electrodoméstico, excepto según se estipula a continuación, cuando se compruebe que los materiales o la mano de obra estén defectuosos siempre que se instale, utilice y mantenga dicho electrodoméstico según las instrucciones proporcionadas. Para los electrodomésticos que están fabricados con un compresor, se proporciona una garantía adicional de dos (2) años para el compresor únicamente.

Exclusiones

La presente garantía no cubre lo siguiente:

1. Productos en los que el número de serie original se ha quitado, modificado o no se puede determinar fácilmente.
2. Desgaste normal y deterioro gradual.
3. Productos que se hayan transferido de su dueño original a otra parte o trasladado fuera de EE. UU. o Canadá.
4. Herrumbre en el interior o exterior de la unidad.
5. Productos comprados "en su estado actual".
6. Pérdida de alimentos debido a una falla del refrigerador o congelador.
7. Daños producidos en cualquier momento durante el envío.
8. Llamadas al servicio técnico que no impliquen funcionamiento incorrecto o defectos en los materiales o la mano de obra, o para los electrodomésticos utilizados de otra forma que no sea de acuerdo con las instrucciones proporcionadas.
9. Llamadas al servicio técnico para corregir la instalación de su electrodoméstico o aprender cómo se utiliza su electrodoméstico.
10. Gastos por hacer accesible el electrodoméstico para el servicio técnico, tales como extracción de adornos, armarios, estantes etc., que no forman parte del electrodoméstico cuando se envía de fábrica.
11. Llamadas al servicio técnico para reemplazar lámparas, filtros de aire, filtros de agua y otros insumos del electrodoméstico, o perillas, manijas y otras piezas decorativas.
12. Sobrecargos que incluyen, entre otros, todo servicio técnico fuera de horario, durante feriados o fines de semana, peajes, cargos de viaje en transbordador o gastos de millaje para el servicio técnico en áreas remotas, incluso el estado de Alaska.
13. Daños en el acabado del electrodoméstico o en el lugar donde este se encuentra ubicado producidos durante la instalación, que incluyen, entre otros, suelo, gabinetes, paredes, etc.
14. Daños provocados por: servicios técnicos realizados por empresas de servicio no autorizadas; uso de piezas que no sean las piezas genuinas de Electrolux o piezas obtenidas de personas que no sean las empresas de servicio técnico autorizado, o causas externas como abuso, uso incorrecto, suministro de alimentación inadecuado, accidentes, incendios o casos fortuitos.
15. Para los electrodomésticos operados por un concesionario o distribuidor en un remolque u otro vehículo a motor, o en diversos lugares, su electrodoméstico cuenta con un (1) año de garantía limitada para piezas y mano de obra. Para los electrodomésticos que están fabricados con un compresor, se proporciona una garantía adicional de cuatro (4) años para el compresor únicamente.

EXENCIÓN DE RESPONSABILIDAD DE LAS GARANTÍAS IMPLÍCITAS; LIMITACIÓN DE LOS RECURSOS

EL RECURSO ÚNICO Y EXCLUSIVO DEL CLIENTE BAJO ESTA GARANTÍA LIMITADA SERÁ LA REPARACIÓN O EL REEMPLAZO DEL PRODUCTO COMO SE ESTABLECE EN EL PRESENTE. LOS RECLAMOS BASADOS EN GARANTÍAS IMPLÍCITAS, INCLUSO GARANTÍAS DE COMERCIALIZACIÓN O APTITUD PARA UN FIN EN PARTICULAR, SE LIMITAN A UN (1) AÑO O EL MENOR TIEMPO PERMITIDO POR LA LEY, PERO NO MENOS DE UN (1) AÑO. ELECTROLUX NO SERÁ RESPONSABLE DE DAÑOS IMPORTANTES O INHERENTES COMO DAÑO MATERIAL Y GASTOS INHERENTES QUE RESULTEN DE CUALQUIER INCUMPLIMIENTO DE ESTA GARANTÍA LIMITADA ESCRITA O CUALQUIER GARANTÍA IMPLÍCITA. ALGUNOS ESTADOS Y PROVINCIAS NO PERMITEN LA EXCLUSIÓN O LIMITACIÓN DE DAÑOS INHERENTES O IMPORTANTES, O LAS LIMITACIONES EN LA DURACIÓN DE LAS GARANTÍAS IMPLÍCITAS, DE MANERA QUE ESTAS LIMITACIONES O EXCLUSIONES PUEDEN NO APLICARSE EN SU CASO. LA PRESENTE GARANTÍA ESCRITA LE OTORGA DERECHOS LEGALES ESPECÍFICOS. ES POSIBLE QUE TENGA OTROS DERECHOS QUE VARIÉN DE UN ESTADO A OTRO.

Si necesita servicio técnico Para obtener servicio, la unidad debe registrarse primero en KelvinatorCommercial.com. Una vez registrado, llame al 866-738-1640 para obtener ayuda.

Esta garantía solo se aplica en los EE. UU. Y Canadá y está garantizada por Electrolux Professional Group SPA.

Electrolux no autoriza a ninguna persona a cambiar o agregar a ninguna obligación en virtud de esta garantía. Las obligaciones de servicio y piezas bajo esta garantía deben ser realizadas por Electrolux o una compañía de servicio autorizada. Las características o especificaciones del producto descritas o ilustradas están sujetas a cambios sin previo aviso.

(diciembre de 2018)

1.866.738.1640

Electrolux Professional
Group North America
10200 David Taylor Drive
Charlotte, NC 28262



Informations concernant la garantie des électroménagers commerciaux Kelvinator

Votre appareil est couvert par une **garantie limitée de trois (3) ans**. Pendant trois (3) ans à partir de la date d'achat d'origine, Electrolux assumera les coûts, sauf dans les cas cités ci-dessous, pour toute réparation ou remplacement de pièce de cet appareil si ce dernier présente un défaut de fabrication ou un vice de matériau, à la condition que l'appareil soit installé, utilisé et entretenu selon les instructions fournies. Pour les appareils munis d'un compresseur, une garantie additionnelle de deux (2) ans sur les pièces est offerte uniquement pour le compresseur.

Exclusions

Cette garantie ne couvre pas ce qui suit :

1. Les produits dont le numéro de série original a été enlevé, modifié ou n'est pas facilement lisible.
2. Usure normale ou détérioration progressive.
3. Les produits qui ont été transférés de leur propriétaire initial à une autre personne ou qui ne sont plus aux États-Unis ou au Canada.
4. La rouille à l'intérieur ou à l'extérieur de l'appareil.
5. Les produits achetés « tels quels ».
6. Les aliments perdus suite à une défaillance du réfrigérateur ou du congélateur.
7. Les dommages subis à un moment quelconque en cours d'expédition.
8. Les appels de service qui ne concernent pas un mauvais fonctionnement, un défaut de fabrication ou un vice de matériau, ou pour les appareils qui ne sont pas utilisés conformément aux instructions fournies.
9. Les appels de service visant à vérifier et corriger l'installation de votre appareil ou à obtenir des instructions concernant son utilisation.
10. Les frais encourus pour accéder à des parties de l'appareil pour une réparation, par exemple, le retrait des finitions, des placards, des étagères, etc., qui ne faisaient pas partie de l'appareil lorsqu'il a quitté l'usine.
11. Les appels de service concernant le remplacement des ampoules, des filtres à air, des filtres à eau ou autres matériaux de consommation, ou des boutons, des poignées et autres pièces esthétiques.
12. Les frais supplémentaires comprenant, mais ne s'y limitant pas, les appels de service en dehors des heures normales de bureau, en weekend ou jours fériés, les droits de péage, les frais de convoyage ou les frais de déplacement pour les appels de service dans des endroits isolés, notamment l'état de l'Alaska.
13. Les dommages causés à la finition de l'appareil ou à l'endroit où il est placé pendant l'installation, y compris, sans s'y limiter, les planchers, les placards, les murs, etc.
14. Les dommages causés par : des réparations faites par des techniciens non autorisés ; l'utilisation de pièces autres que les pièces Electrolux d'origine ou des pièces qui n'ont pas été obtenues par l'entremise d'un réparateur autorisé ; ou des causes externes comme l'usage abusif, le mauvais usage, l'emploi d'une alimentation électrique inadéquate, les accidents, les incendies ou les catastrophes naturelles.
15. Dans le cas d'appareils opérés dans une remorque ou tout autre véhicule motorisé par un concessionnaire ou un détaillant, votre appareil sera couvert par une garantie limitée sur les pièces et la main-d'œuvre d'un (1) an. Pour les appareils munis d'un compresseur, une garantie additionnelle de quatre (4) ans sur les pièces est offerte uniquement pour le compresseur.

EXONÉRATION CONCERNANT LES GARANTIES IMPLICITES ; LIMITATIONS DES RECOURS

L'UNIQUE RECOURS DU CLIENT EN VERTU DE CETTE GARANTIE LIMITÉE EST LA RÉPARATION OU LE REMPLACEMENT DU PRODUIT, TEL QUE DÉCRIT PRÉCÉDEMMENT. LES RÉCLAMATIONS BASÉES SUR DES GARANTIES IMPLICITES, Y COMPRIS LES GARANTIES IMPLICITES DE QUALITÉ MARCHANDE OU D'ADÉQUATION À UN USAGE PARTICULIER, SONT LIMITÉES À UN (1) AN OU À LA PÉRIODE LA PLUS COURTE PERMISE PAR LA LOI, QUI NE DOIT PAS ÊTRE INFÉRIEURE À UN (1) AN. ELECTROLUX NE POURRA ÊTRE TENU RESPONSABLE DES DOMMAGES ACCESSOIRES OU INDIRECTS NI DES DOMMAGES MATÉRIELS ET DES DÉPENSES IMPRÉVUES RÉSULTANT D'UNE VIOLATION DE CETTE GARANTIE ÉCRITE OU DE TOUTE AUTRE GARANTIE IMPLICITE. CERTAINS ÉTATS ET CERTAINES PROVINCES NE PERMETTENT AUCUNE RESTRICTION OU EXEMPTION SUR LES DOMMAGES ACCESSOIRES OU INDIRECTS NI RESTRICTION SUR LES GARANTIES IMPLICITES. DANS CE CAS, CES LIMITATIONS OU EXCLUSIONS POURRAIENT NE PAS S'APPLIQUER À VOUS. CETTE GARANTIE ÉCRITE VOUS DONNE DES DROITS LÉGAUX PRÉCIS. IL SE PEUT QUE VOUS AYEZ D'AUTRES DROITS, QUI PEUVENT VARIER D'UN ÉTAT OU D'UNE PROVINCE À L'AUTRE.

Si vous devez faire appel au service après-vente Afin d'obtenir un service, l'appareil doit d'abord être enregistré sur KelvinatorCommercial.com. Une fois inscrit, appelez le 866-738-1640 pour obtenir de l'aide.

Cette garantie s'applique uniquement aux États-Unis et au Canada et est garantie par Electrolux Professional Group SPA.

Electrolux n'autorise personne à modifier ou à ajouter des obligations en vertu de la présente garantie. Les obligations de service et de pièces dans le cadre de cette garantie doivent être exécutées par Electrolux ou une société de service agréée. Les caractéristiques ou spécifications du produit telles que décrites ou illustrées sont sujettes à modification sans préavis.

(Décembre 2018)

1.866.738.1640

Electrolux Professional
Group North America
10200 David Taylor Drive
Charlotte, NC 28262

