



INSIGHT·PRO®



The Sharp Insight Pro® Microwave Drawer® is the **world's first 24-inch Microwave Drawer**. It places the microwave at a very convenient height for frequent use. Now microwave cooking is easier for every cook in the family, with no need to remove the dish from the oven to check, stir or turn the food. For even greater convenience, the new Easy Open Microwave Drawer opens automatically with a gentle pull of the handle. Just push it gently and it closes automatically, even if your hands are full.

Sharp's advanced sensor technology eliminates the guesswork often associated with microwave cooking. The Microwave Drawer is large enough to hold a 9" x 13" oblong dish, and the Auto-Touch™ control panel is angled so it is more convenient and easier to use. With fresh thinking into how consumers really use their kitchens, Sharp puts innovation and cooking convenience at your fingertips. The Insight Pro Microwave Drawer: it's the most exciting idea yet for where to place the microwave.

Design Flexibility

The world's first 24-inch Microwave Drawer is built-in ready for easy installation without the need for an additional kit. It eliminates awkward installations and cluttered countertops, making it ideal for open-plan kitchens and islands.

Innovative Technology

The Microwave Drawer provides superb access, placing the microwave at a very convenient height. Its microwave sensor technology eliminates guesswork when cooking or reheating.

Convenience and Accessibility

The angled touch controls are convenient and easy to use. In addition, there is no need to remove the dish from the oven to check, stir, or turn the food. For even greater convenience, a gentle pull on the handle opens the Microwave Drawer automatically. Just push it gently and it closes automatically, too.

Sophisticated Style

The large viewing window, along with an integrated handle and angled touch controls, results in a sleek, sophisticated appearance that's an ideal complement to any kitchen decor.

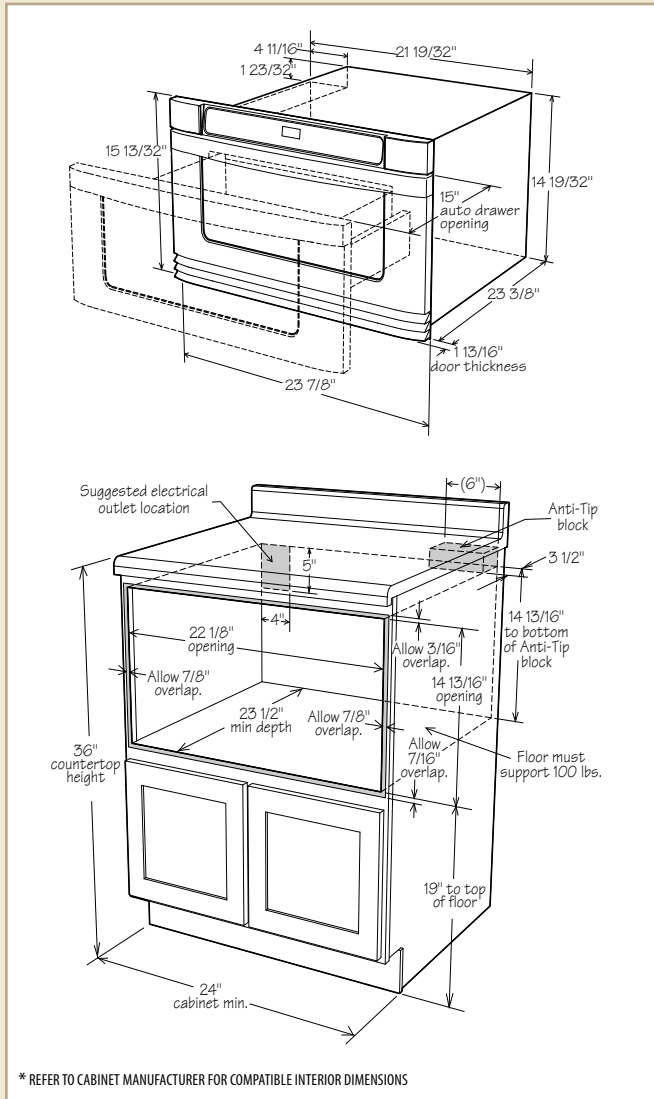

SPECIFICATIONS	FEATURES	KB-6024MS/MK/MW
Controls	Front-mounted touch controls, angled for easy viewing	•
	Digital LCD display	•
	Kitchen timer	•
	Control lock	•
	Demonstration mode	•
Microwave Drawer	1.0 cu. ft. capacity (holds 9" x 13" dish)	•
	1000W output power	•
	Microwave Drawer opening system	Automatic Easy Open
	Sensor Cook, Reheat, Popcorn	11 settings
	Preprogrammed Reheat	3 settings
	Automatic Defrost	5 settings
	Microwave Keep Warm	Up to 30 minutes
	Variable power levels	11
	Programmable stages	4
	Clock	•
Minute Plus™	•	
Color	Stainless	KB-6024MS
	Black	KB-6024MK
	White	KB-6024MW
Outside Dimensions	23 7/8" w x 15 13/32" h x 26 3/16" d (with handle)	
Approx. Shipping Weight	103 lbs.	
Power/Ratings	120V, 60Hz / 1.67kW, 14.5 Amps	
Safety Compliance	FCC, DHHS, UL listed	
UPC Codes	KB-6024MS:	074000 616776
	KB-6024MK:	074000 616783
	KB-6024MW:	074000 616790
Limited Warranty	One-year parts and one-year labor with in-home service. The warranty continues for an additional four years, for a total of five years, on the magnetron tube for parts only.	

Design and specifications subject to change without notice. Sharp, Insight Pro and Microwave Drawer are registered trademarks of Sharp Corporation. All other trademarks are property of their respective owners.

To receive the most current specifications visit www.dexpress.com or call Dimension Express at 925-284-3558 from a fax machine. Enter code 9026 for instructions and a directory of Sharp microwave oven products.

For information including limited warranty, complete dimensions, installation instructions and tips, please visit www.sharpusa.com/microwavedrawer.



INSIGHT·PRO®
Microwave Drawer
Best New Kitchen Product 2005
Kitchen/Bath Industry Show
2005 and 2006 Product Innovator Award
Kitchen + Bath Business Magazine

Electronic Catalog Available

