

IW-30CI



FEATURES

- Custom front panel and hardware allow for infinite design options.
- Four independent temperature zones
- Dual evaporators for constant, moderate humidity so corks don't dry out
- Bronze-tinted, UV-resistant glass protects against light exposure
- Full-extension, easy-glide racks provide access without agitating wine
- Flexible storage and LED lighting options
- Automatic ice maker with "max ice" feature
- Intuitive touch control panel keeps temps within one degree of set point
- Home security system connection
- Rigorously tested in our U.S. manufacturing facilities to ensure decades of use
- Exceptional 24/7 support from Madison, WI-based Customer Care team
- New inventory tiles system lets you label wine racks for easy ID

ACCESSORIES

- 30" Bulk Storage Drawer
- Cherrywood Humidor
- Dessert Wine Rack
- Door Lock Kit
- Wine inventory tiles
- Wine inventory tiles-writable
- Dual Installation Kits
- Reduced toe kick divider for toe kicks from 3.875" to 2"
- Side enclosure
- Top enclosure
- Stainless steel pro handles
- Stainless steel tubular handles
- Stainless Steel Drawer Panels With Pro Handles
- Stainless Steel Drawer Panels With Tubular Handles
- Stainless Steel Door Panels With Pro Handle
- Stainless Steel Door Panels With Tubular Handle
- Solid Panel Ready Door
- Stainless Steel Dual Installation Kickplates

Accessories are available through an authorized dealer. For local dealer information, visit subzero-wolf.com/locator.



HANDLE ACCESSORIES

PRO



TUBULAR



PRODUCT SPECIFICATIONS

Model	IW-30CI
Dimensions	30"W x 84"H x 24"D
Door Clearance	28 1/2"
Weight	490 lbs
Electrical Supply	115 VAC, 60 Hz
Electrical Service	15 amp dedicated circuit
Wine Storage Capacity	86 Bottles
Drawer Capacity	5.0 cu. ft.
Receptacle	3-prong grounding-type

DIMENSIONS

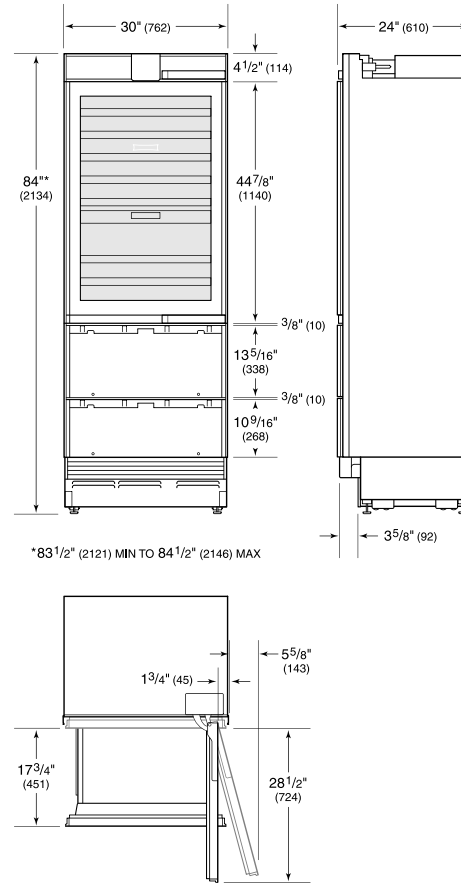

ELECTRICAL

PLUMBING

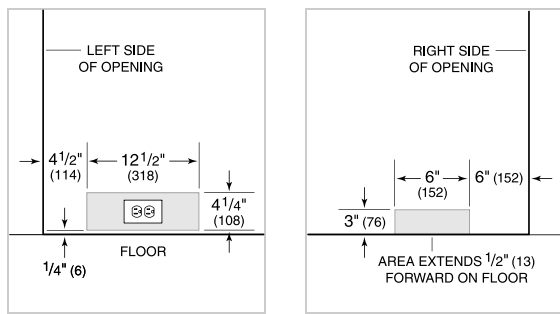

NOTE: Dimensions in parenthesis are in millimeters unless otherwise specified

INTERIOR VIEW



This illustration is intended for interior reference only and may not represent the exterior of the model being specified.

STANDARD INSTALLATION

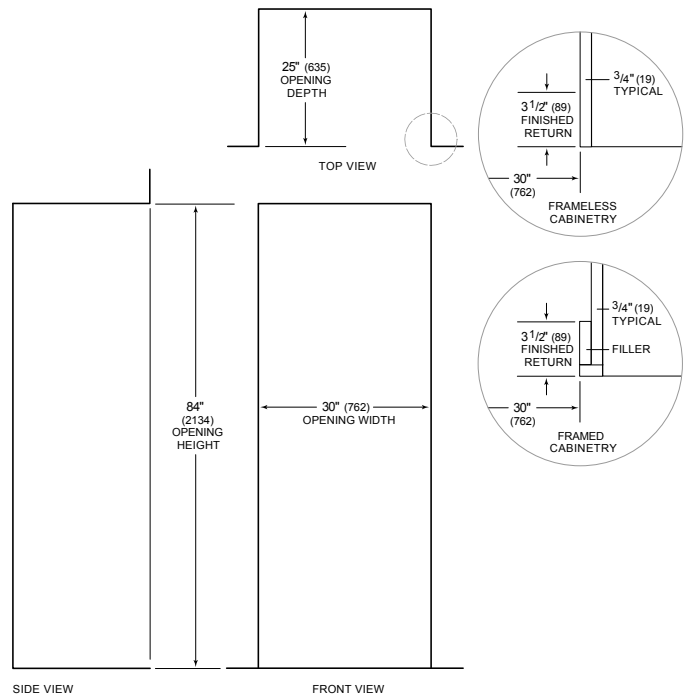

NOTE: 3 1/2" (89) finished returns will be visible and should be finished to match cabinetry