

48" Dual Fuel Range with Griddle

Model: HR 1956 DF GD / HR 1956 DF GD LP



HR 1956 DF GD / HR 1956 DF GD LP

Features:

- M Touch controls and backlit knobs
- M Pro dual stacked burner system with TrueSimmer
- M Pro Griddle
- ComfortClean dishwasher-safe grates
- TwinPower Convection fans
- 21 Operating modes including Self-Clean
- Moisture Plus
- MasterChef and MasterChef Plus automatic programs
- Wireless Roast Probe
- Soft Close and Soft Open
- Clean Touch Steel™ front
- Fully functional M Touch Speed Oven (Combination of Convection Oven and Microwave)
- Fully functional Warming Drawer

SPECIFICATIONS

HR 1956 DF GD — Item 25195651USA

HR 1956 DF GD LP — Item 25195652USA

Overall Unit Width	48" (1219.2mm)
Overall Height	34 ⁹ / ₁₆ " — 36 ¹ / ₁₆ " (877.7 — 915.8mm)
Overall Unit Depth to front of control panel	26 ¹ / ₂ " (673mm)
Oven Door Clearance	22 ¹ / ₄ " (565mm)
Niche	
Minimum Cabinet Niche Width	48 ¹ / ₁₆ " + ¹ / ₁₆ " (1220.8 — 1222.4mm)
Minimum Cabinet Opening Height	35 ¹ / ₂ " — 37" (901.7 — 939.8mm)
Burners	
Gas Burners:	(2) 12,000 BTU; (4) 19,000 BTU
Griddle:	(1) 15,000 BTU
Electrical	
Electrical Requirements	120V / 240V, 60Hz, 50 Amps 120V / 208V, 60Hz, 50 Amps
Power Cord	Yes - NEMA 14-50 plug, 5.5 ft. (167.6cm) long
Shipping	
Shipping Weight	617.3 lbs. (280kg)
Support	
Call	800.843.7231
20/20	©2020technologies.com

48" Dual Fuel Range with Griddle

Model: HR 1956 DF GD / HR 1956 DF GD LP



PRODUCT VIEWS

Isometric

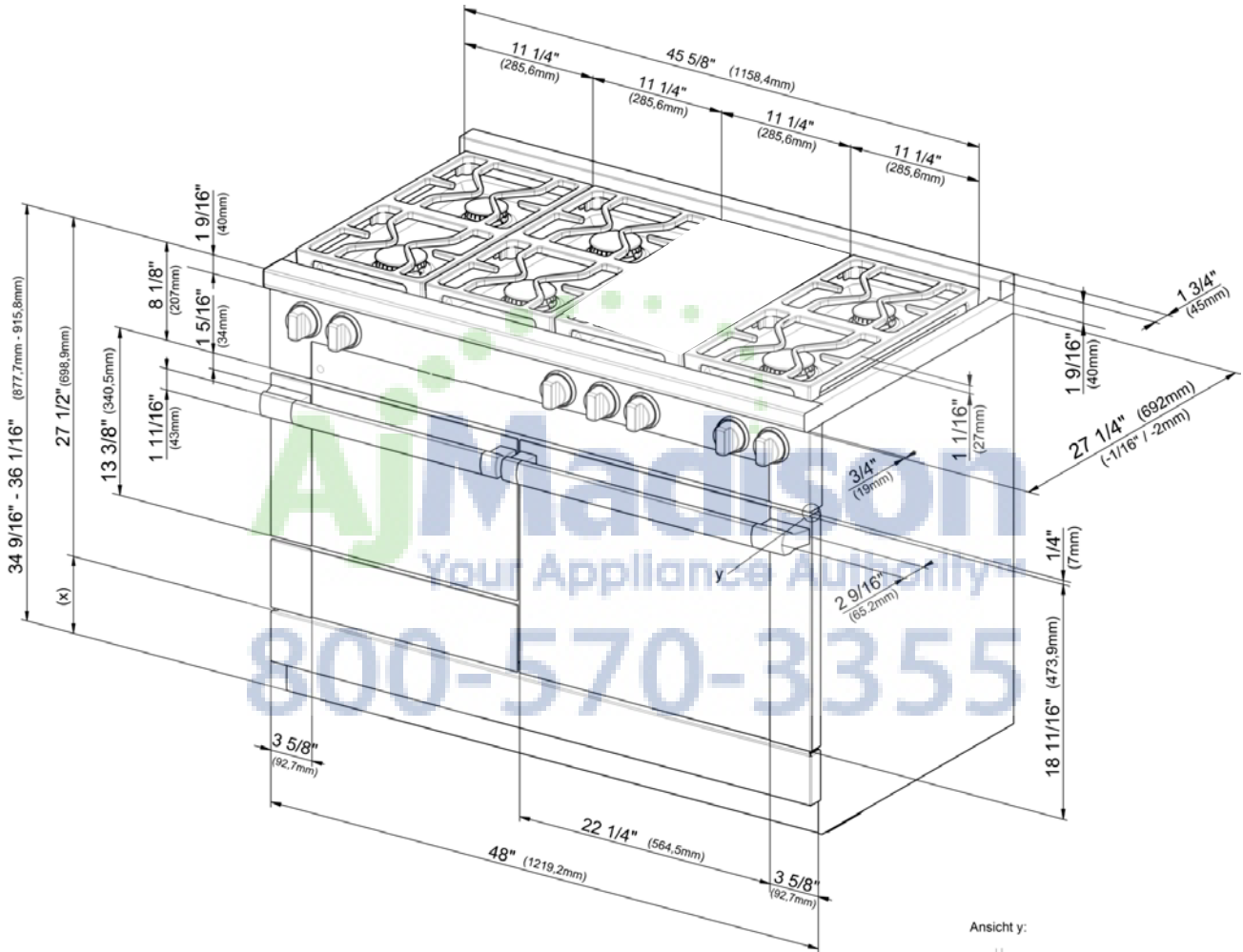

(x) = Toe-kick height adjustment 4" – 5 1/2" (101.6 – 139.7mm)



48" Dual Fuel Range with Griddle

Model: HR 1956 DF GD / HR 1956 DF GD LP



PRODUCT VIEWS

Rear View

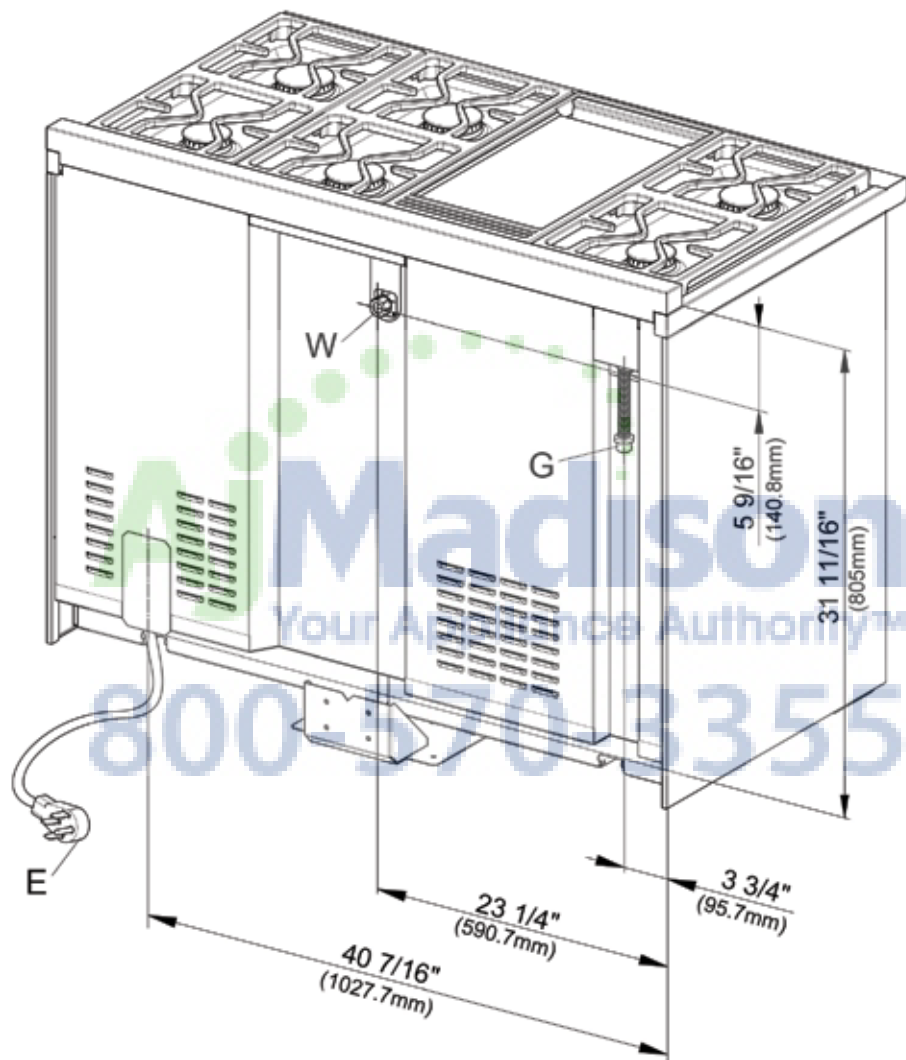

E = Electrical connection

W = Plumbing

G = Gas connection

48" Dual Fuel Range with Griddle

Model: HR 1956 DF GD / HR 1956 DF GD LP



PRODUCT VIEWS

Detailed Side View

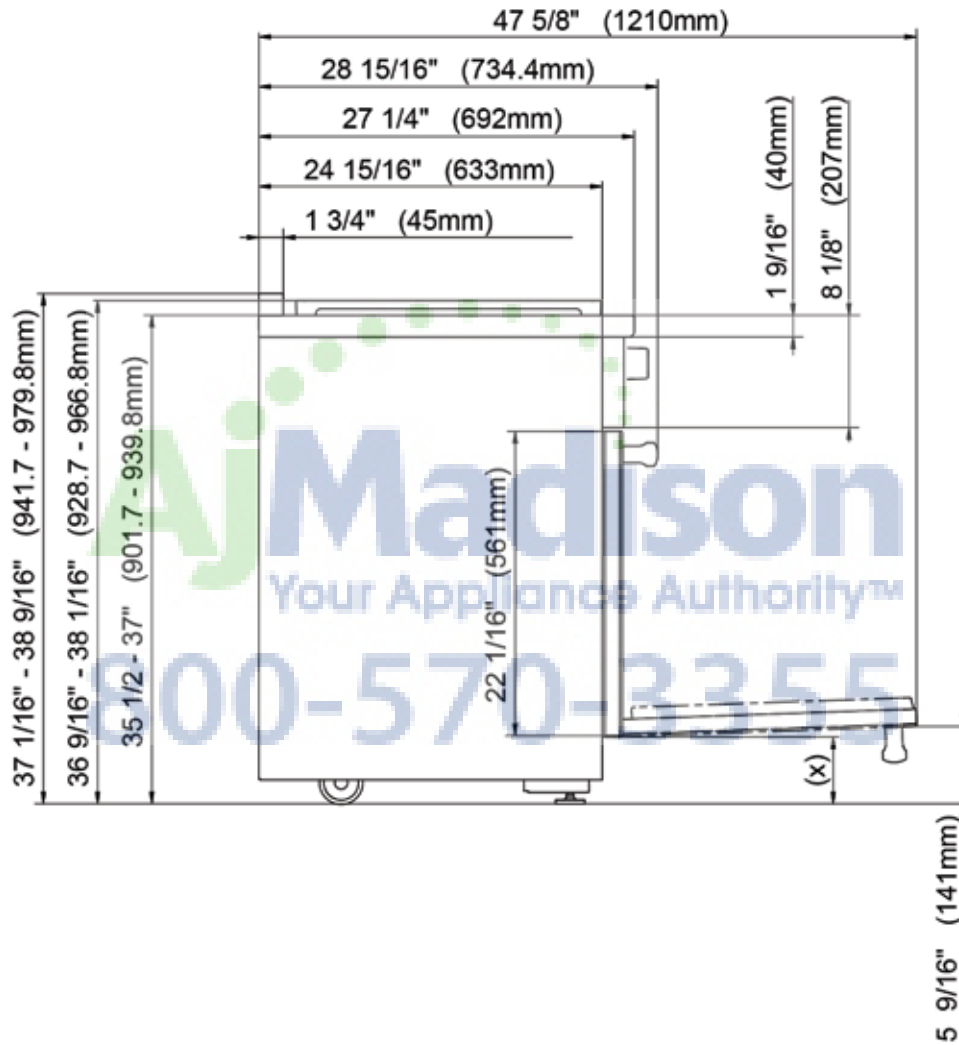

(x) = Depending on the appliance height adjustment: 4" - 5 1/2" (101.6 mm - 139.7 mm)

48" Dual Fuel Range with Griddle

Model: HR 1956 DF GD / HR 1956 DF GD LP



PRODUCT VIEWS

Detailed Front Side View

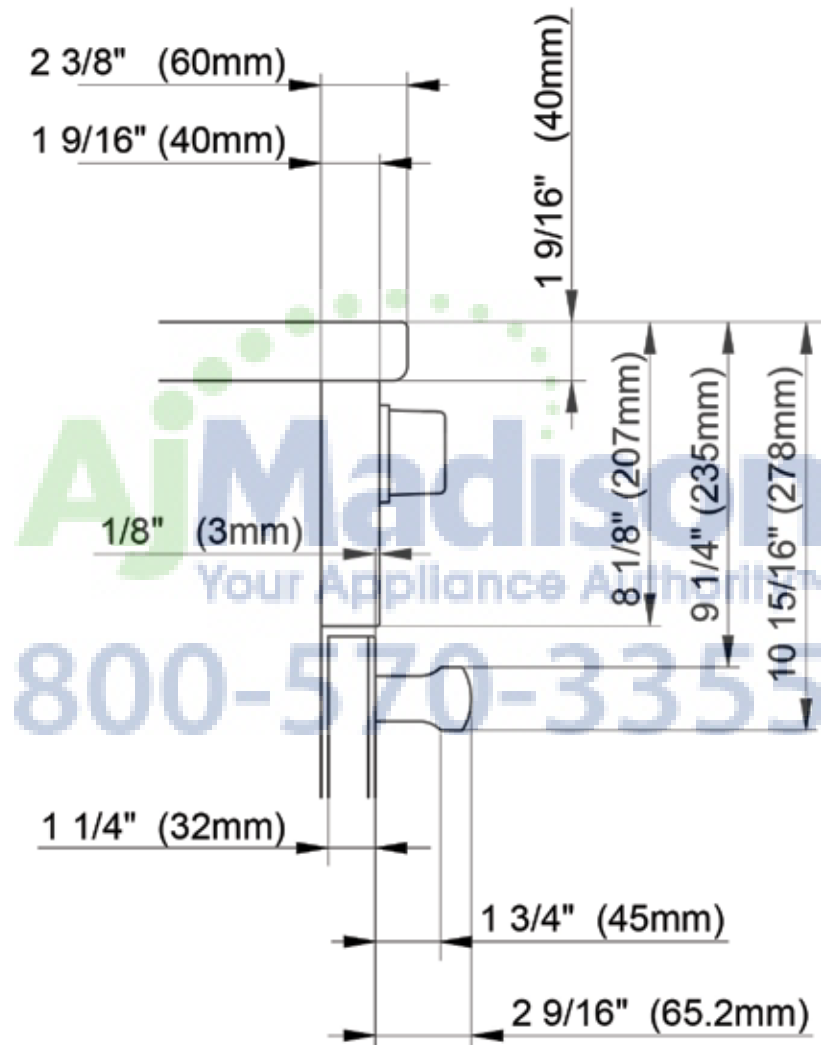

48" Dual Fuel Range with Griddle

Model: HR 1956 DF GD / HR 1956 DF GD LP



PRODUCT VIEWS

Cabinet View

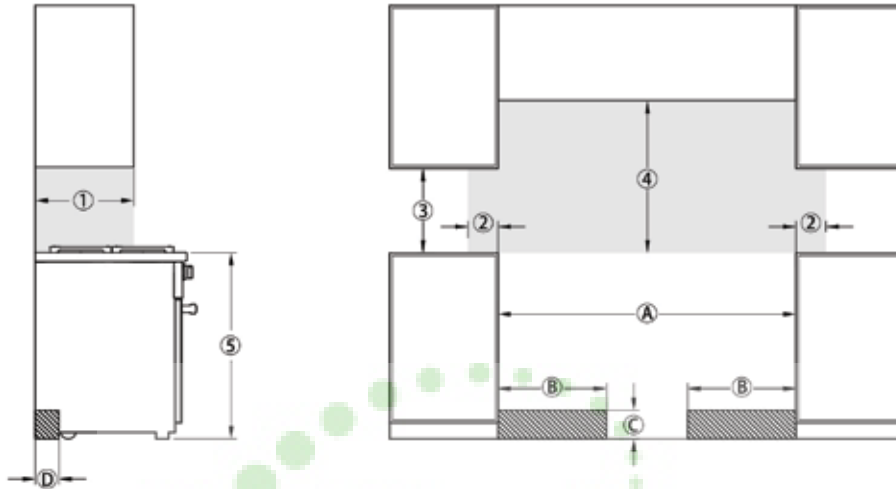

Position	Dimension [inches]	Description
①	13"	Maximum depth of top cabinet
②	6"	Minimum distance (left and right) to flammable surfaces
③	18"	Minimum distance to bottom edge of top cabinet
④	30"	Minimum distance between the top of the cooking area and the bottom of an unprotected wooden or metal cabinet
⑤	35 1/2"–37"	Distance from floor to cooktop surface
A	48 1/16" + 1/16"	Width of cabinet niche
B	approx. 20 1/2" (518 mm)	Maximum connection width right and left
C	approx. 3 1/2" (90 mm)	Maximum connection height
D	approx. 2 13/16" (72 mm)	Maximum connection depth

The gray areas represent the minimum distance from flammable surfaces.

The hatched areas represent the installation areas for the connections.

For island installations, 12" minimum distance from back of range to flammable rear wall above countertop.

For gas, electric and water connections, see Rear Product View