



24" Signature Series Wine Reserve Specification Sheet

Model Numbers

- HP24WS-1 HP24WO-1
- HP24WS-2 HP24WO-2
- HP24WS-3 HP24WO-3
- HP24WS-4 HP24WO-4



24" Wine Reserve Features:

- Designed with fully-integrated depth to allow flush fit with surrounding cabinetry (with 3/4" wood overlay)
- Zero-clearance hinging allows for abutment with surrounding cabinetry
- Perlick's exclusive Variable Speed Compressor
- Front-vented, forced-air refrigeration
- Industry Exclusive full-extension shelves
- Industry Exclusive stainless steel interior
- Two (2) year full warranty on complete unit – Additional four year limited warranty on the sealed refrigeration system
- Industry Exclusive Convertible Door Design allows all doors to be converted to wood overlay from stainless steel
- Low E, UV coated glass provides industry leading insulation and protection
- Door locks available
- Interior digital display
- Five shelves will store 40 wine bottles
- Extra storage under shelves for up to five additional bottles
- Stainless steel ball bearing glides provide smooth movement of shelves
- Shelves are removable and adjustable to accommodate oversize (magnum) bottles
- Cabinet construction eliminates vibration transfer to reserve
- Wine Reserve temperature 40 – 65 degrees F
- Available with solid stainless steel door, glass door, solid wood overlay door or glass door with wood overlay trim
- Each wine shelf is finished with a contemporary stainless steel front
- 5.3 cubic feet of capacity



Luxury YOU DESIRE.
INNOVATION YOU CAN'T LIVE WITHOUT.



8300 W. Good Hope Rd. • Milwaukee, WI 53223
1-800-558-5592 • Fax: (414) 353-7069 • www.Perlick.com

Perlick is committed to continuous improvement. Therefore, we reserve the right to change specifications without warning

Indoor Models	Outdoor Models	Wine Reserves
HP24WS-1L	HP24WO-1L	24" wine reserves with solid stainless door
HP24WS-2L	HP24WO-2L	24" wine reserves with solid wood overlay door
HP24WS-3L	HP24WO-3L	24" wine reserves with stainless glass door
HP24WS-4L	HP24WO-4L	24" wine reserves with wood overlay glass door

Job _____
Area _____
Item No. _____
Model No. _____

Models are specified as left hinge, right hinge is optional

Overall Width: 23-7/8", 60.643 cm
Overall Height: 34-5/16", 87.154 cm
Overall Depth: 23-15/16", 59.214 cm
Capacity: 5.3 cubic ft.
Minimum Height Required: 34-1/8"
Door Swing Clearance: 24-25/32"
Annual Energy Usage: 225 kWh/yr – \$25
Electrical: 115V, 60 Hz., 1 phase AC, 2.3 amps
Plumbing: none required
Shipping Weight: 215 lbs., 97.522 kg

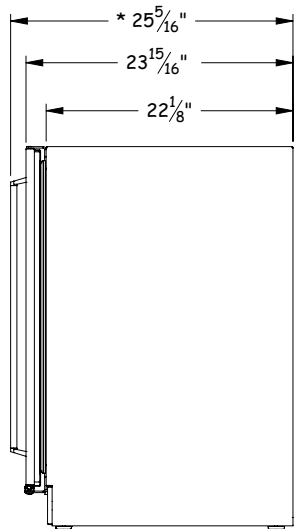
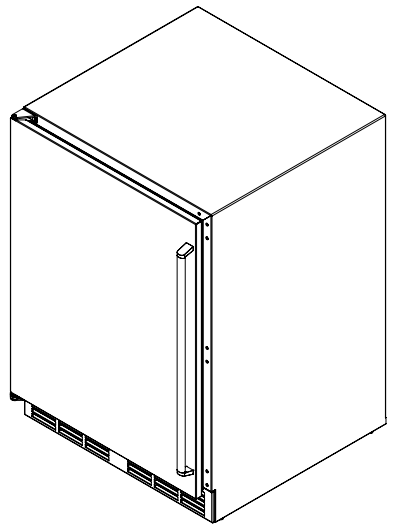
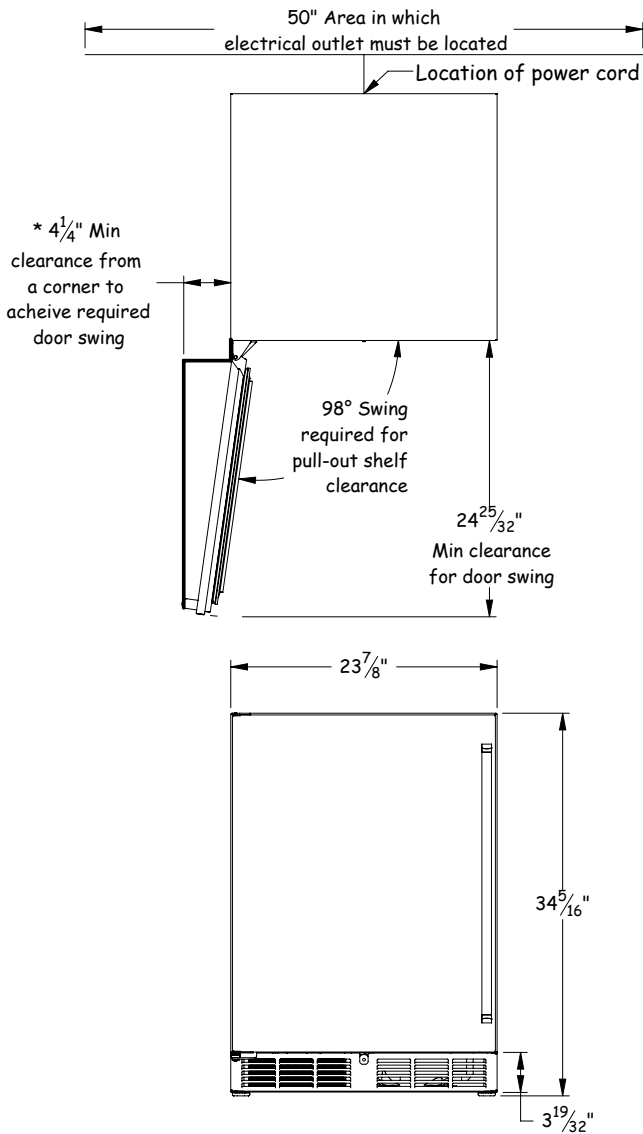

* - Values may change due to custom pull with a wood overlay door



8300 W. Good Hope Rd. • Milwaukee, WI 53223

1-800-558-5592 • Fax: (414) 353-7069 • www.Perlick.com

Perlick is committed to continuous improvement. Therefore, we reserve the right to change specifications without warning