

Friedrich

2007 Service & Parts Manual

AjMadison
Your Appliance Authority™

Hazardgard 800-570-3355

Room Air Conditioners
60 Hz Models

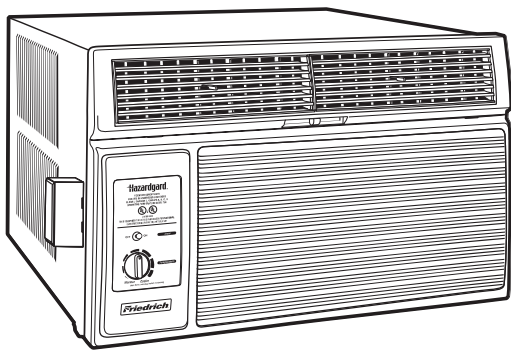

SH15L30-B

SH20L30-B

TABLE OF CONTENTS

Specifications	3
Performance Data.....	3
Component Operation & Testing	4
Compressors.....	4
Thermal Overload	4
Checking Compressor Efficiency.....	4
Fan Motor	5
Solid State Relay.....	5
System Control Switch	5
Run Capacitor	5
Thermostat	5
Low Ambient Bypass Valve.....	6
Sealed Refrigeration System Repairs.....	6
Hermetic Component Replacement	7
Special Procedure in the case of Compressor Motor Burn-Out	7
Rotary Compressor Special Troubleshooting & Service	7
Refrigerant Charge.....	7
Troubleshooting	8-10
Wiring Diagram	11
Cabinet Parts Diagram.....	12
Chassis Parts Diagram	13
Parts List	14-15
Warranty.....	16



Performance Data: Cooling

	EVAPORATOR AIR TEMP. DEG. F		EVAPORATOR TEMP. DEG. F		CONDENSER TEMP. DEG. F		Discharge Temp	Suction Temp	Liquid Temp	Super Heat	Sub-Cooling	OPERATING PRESSURES		ELECTRICAL RATINGS		R-22 REF.	Evap CFM	Motor RPM	BREAKER FUSE
	Discharge Air	Temp. Drop F.	E(in)	E(out)	E(in)	E(out)						Suction	Discharge	Amps Cool	Amps Heat				
60 Hz Models																			
SH15L30-B	54	26	52	56	206	129	61	108	16	98	76	258	8.2	-	-	28.5	363	1100	15
SH20L30-B	46	34	46	46	125	196	52	97	8	28	75	271	10.1	-	-	39.0	357	1100	20

Product Specifications

Model	Cooling Capacity		Electrical Characteristics (60 Hertz)		Energy Efficiency Ratio AHAM	Moisture Removal	Air Direction Controls	Room Side Air Circulation
	(BTU/Hr.- AHAM)	Volts Rated	Amps AHAM	Watts				
SH15L30	15000/15000	230/208	7.9/8.7	1765/1765	8.5/8.5	4.0	8-way	375
SH20L30	19800/19500	230/208	10.0/10.9	2200/2167	9.0/9.0	5.7	8-way	375

Installation Information

Model	Dimensions (Inches)			Window Width (Inches)	Thru-The-Wall Finished Hole (Inches)	Circuit Rating Breaker or T - D Fuse	Weight (Lbs.)						
	Height	Width	Depth Overall					Minimum Extension Into Room	Minimum Extension Outside	Max.	Height	Width	Volts - Amps
SH15L30	15 ¹⁵ / ₁₆	25 ¹⁵ / ₁₆	27 ³ / ₈	9 ³ / ₁₆	3 ¹ / ₁₆	16 ¹⁵ / ₁₆	27 ⁷ / ₈	42	16 ³ / ₁₆	26 ³ / ₁₆	250V - 15A	140	152
SH20L30	17 ¹⁵ / ₁₆	25 ¹⁵ / ₁₆	27 ³ / ₈	9 ³ / ₁₆	3 ¹ / ₁₆	16 ¹⁵ / ₁₆	27 ⁷ / ₈	42	18 ³ / ₁₆	26 ³ / ₁₆	250V - 15A	166	179

Due to continuing engineering research and technology, specifications are subject to change without notice. Manufactured under U.S. Design Patent DES 368, 306 decorative front; Utility Patent 5, 622, 058
 MAXIMUM outdoor ambient operating temperature is 130°F (54°C).
 MAXIMUM TEMPERATURE RATING FOR CLASS 1, DIVISION 2, GROUPS A,B,C,D

OPERATING TEMPERATURE CODE T3B

COMPONENT OPERATION AND TESTING

WARNING

DISCONNECT ELECTRICAL POWER TO THE UNIT BEFORE SERVICING OR TESTING

COMPRESSORS

Compressors are single phase, 208/230 volt. All compressor motors are permanent split capacitor type, using only a running capacitor across the start and run terminal.

All compressors are internally spring mounted and externally mounted on rubber isolators.

Line Voltage Overload

The compressor is equipped with an internal line voltage overload. This overload is embedded in the windings of the motor to sense the motor temperature. The overload will open and disconnect the power to the motor due to high temperatures caused by:

1. A locked rotor.
2. Excessive running amps.
3. High discharge temperature.
4. Low refrigerant charge.

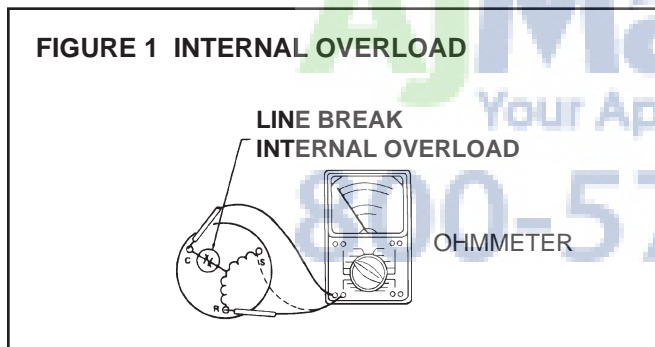

COMPRESSOR WINDING TEST (Figure 2.)

Remove the compressor terminal box cover and disconnect the wires from the terminals. Using an ohmmeter, check continuity across the following:

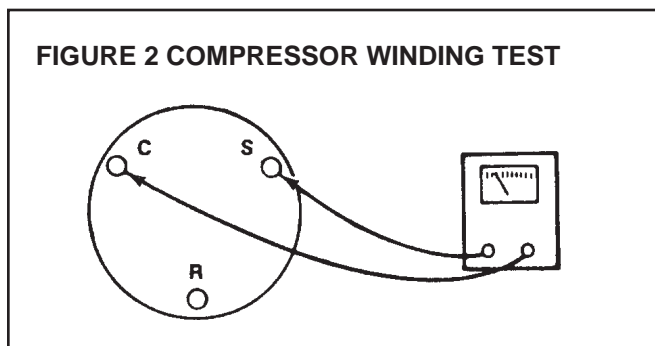

Testing Procedures

1. Terminal "C" and "S" – no continuity – open winding – replace compressor.
2. Terminal "C" and "R" – no continuity – open winding – replace compressor.
3. Terminal "R" and "S" – no continuity – open winding – replace compressor.
4. Terminal "C" and the shell of the compressor – continuity – grounded motor – replace compressor.
5. Should continuity exist between terminals "R" and "S", but not between terminals "C" and "S" and "C" and "R", the internal overload may be open. If the compressor is extremely hot, allow it sufficient time to cool. It may require as long as one hour for the compressor to cool sufficiently for the internal overload to close.

GROUND TEST

Use an ohmmeter set on its highest scale. Touch one lead to the compressor body (clean point of contact, as a good connection is a must) and the other probe in turn to each compressor terminal. (See Figure 3.) If a reading is obtained, the compressor is grounded and must be replaced.

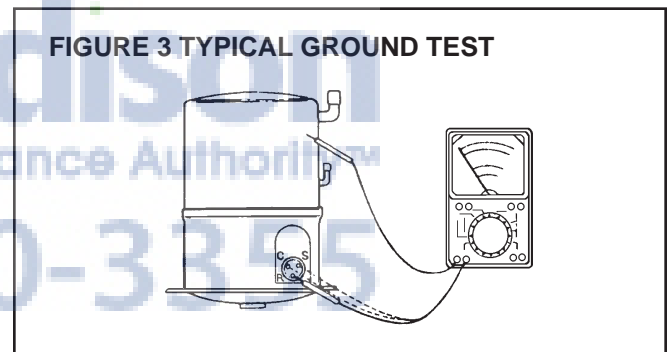

CHECKING COMPRESSOR EFFICIENCY

The reason for compressor inefficiency is normally due to broken or damaged suction and/or discharge valves, reducing the ability of the compressor to pump refrigerant gas.

This condition can be checked as follows:

1. Install a piercing valve on the suction and discharge or liquid process tube.
2. Attach gages to the high and low sides of the system.
3. Start the system. Run a "cooling or heating performance test."

If test shows:

- A. Below normal high side pressure.
- B. Above normal low side pressure.
- C. Low temperature difference across the coil.

The compressor valves are faulty - replace the compressor.

FAN MOTOR (Figure 4)

A 230 volt single phase permanent split capacitor motor is used to drive the evaporator blower and condenser fan. A running capacitor is wired across the start and run terminals of the motor.

The motor is totally enclosed and is protected with a line voltage overload located internally of the motor. The motor shaft is stainless steel to resist corrosion.

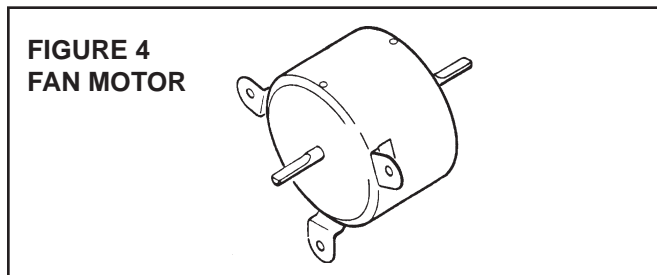

FAN MOTOR – TEST

Disconnect power to the unit.

1. Determine that the capacitor is serviceable.
2. Disconnect the black lead from the circuit board.
3. Apply "live" test cord leads to the common terminal of the capacitor and the black lead. The motor should run at high speed.

SOLID STATE RELAY (Figure 5)

Two 50 amp rated 208/230 volt solid state relays are used to energize the compressor and fan motor. Terminals 3 and 4 are the 208/230 volt line side. Terminals 1 and 2 are load side contacts.

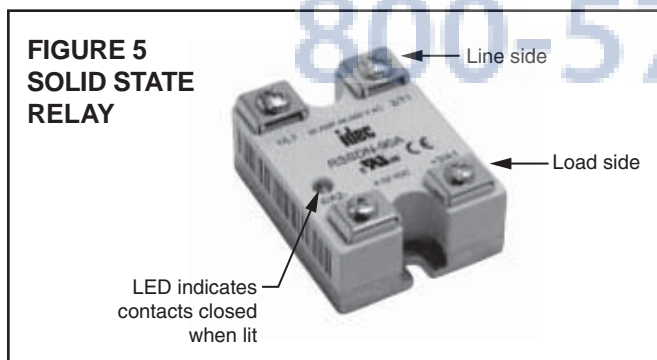

SYSTEM CONTROL SWITCH (Figure 6)

This switch is double pole, single throw. Check for continuity between terminals 2 and 3, and 5 and 6.

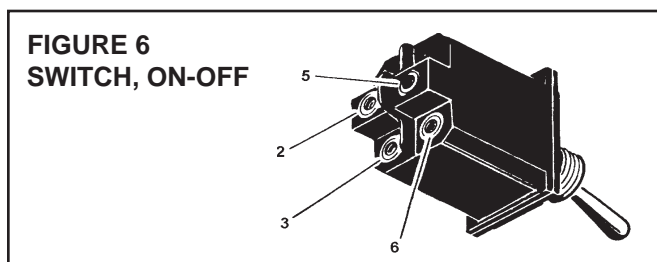

CAPACITOR, RUN

A run capacitor is wired across the auxiliary and main winding of a single phase permanent split capacitor motor such as the compressor and fan motors. A single capacitor can be used for each motor or a dual rated capacitor can be used for both.

The capacitor's primary function is to reduce the line current while greatly improving the torque characteristics of a motor. The capacitor also reduces the line current to the motor by improving the power factor of the load. The line side of the capacitor is marked with a red dot and is wired to the line side of the circuit (see Figure 7.)

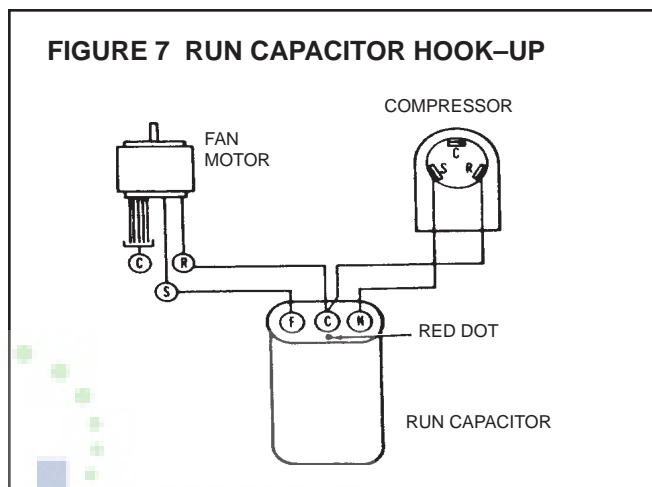

CAPACITOR – TEST

1. Remove the capacitor from the unit.
2. Check for visual damage such as bulges, cracks, or leaks.
3. For dual rated capacitors, apply an ohmmeter lead to the common (C) terminal and the other probe to the compressor (HERM) terminal. A satisfactory capacitor will cause a deflection on the pointer, then gradually move back to infinity.
4. Reverse the leads of the probe and momentarily touch the capacitor terminals. The deflection of the pointer should be two times that of the first check if the capacitor is good.
5. Repeat steps 3 and 4 to check the fan motor capacitor.

NOTE: A shorted capacitor will indicate a low resistance and the pointer will move more to the "0" end of the scale and remain there as long as the probes are connected. An open capacitor will show no movement of the pointer when placed across the terminals of the capacitor.

THERMOSTAT

A cross ambient thermostat is used to maintain the desired comfort level. The thermostat reacts only to a change in temperature at the bulb location. Important to the successful operation of the unit is the position of the sensing bulb in relation to the evaporator (see Figure 8).

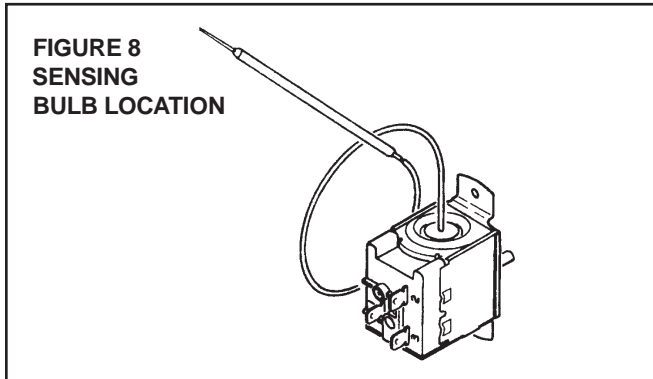

RANGE: Thermostat
(Part No. 618-225-02)
60° F (± 2°) to 90° F (± 4°)

TEST

Remove the wires from the thermostat. Turn the thermostat to its coldest position. Check to see if there is continuity between the two terminals. Turn the thermostat to its warmest position. Check continuity to see if the thermostat contacts open.

Note: The temperature must be within the range listed to check the thermostat. Refer to the troubleshooting section in this manual for additional information on thermostat testing.

LOW AMBIENT BYPASS VALVE (Figure 9)

The HazardGard unit is designed to operate at low outside ambient temperatures. This is accomplished by the use of a bypass valve installed in the refrigeration circuit. The valve is connected between the discharge line at the compressor and the suction process tube. The valve responds to suction pressure which, when reduced in the system, causes the valve to open and bypass hot gas from the high pressure side to the low pressure side of the system. The hot gas entering the compressor mixes with the cool gas returned through the suction line, thus increasing the suction pressure. The valve is preset to open when the suction pressure reaches 50 psig. This pressure setting cannot be altered. The system can be operated at outdoor temperatures as low as 45° F before the evaporator coil will begin to accumulate frost.

To determine if the valve operates, block the return air to the evaporator coil. Turn on the unit and touch the tube at the bypass valve outlet which connects to the suction process tube. When the low side pressure reaches approximately 50 psig, the valve will begin to open and the tube will get hot. This method will determine if the valve is responding to the suction pressure change.

**FIGURE 9
LOW AMBIENT
Bypass VALVE**

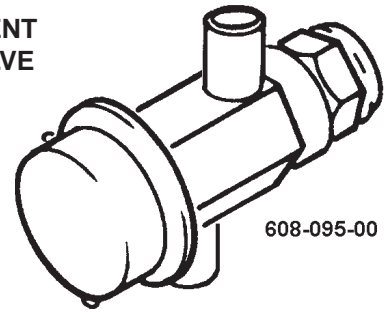

SEALED REFRIGERATION SYSTEM REPAIRS

Equipment Required:

1. Voltmeter
2. Ammeter
3. Ohmmeter
4. E.P.A Approved Refrigerant Recovery System
5. Vacuum Pump (capable of 200 microns or less vacuum).
6. Acetylene Welder
7. Electronic Halogen Leak Detector (G.E. Type H-6 or equivalent).
8. Accurate refrigerant charge measuring device such as:
 - a. Balance Scales - 1/2 oz. accuracy
 - b. Charging Board - 1/2 oz. accuracy
9. High Pressure Gauge - (0-400 lbs.)
10. Low Pressure Gauge - (30" - 150 lbs.)
11. Vacuum Gauge - (0-1000 microns)

Equipment Must Be Capable of:

1. Recovering CFC's as low as 5%.
2. Evacuation from both the high side and low side of the system simultaneously.
3. Introducing refrigerant charge into the high side of the system.
4. Accurately weighing the refrigerant charge actually introduced into the system.
5. Facilities for flowing nitrogen through the refrigeration tubing during all brazing processes.

HERMETIC COMPONENT REPLACEMENT

The following procedure applies when replacing components in the sealed refrigeration circuit or repairing refrigerant leaks. (Compressor, condenser, evaporator, capillary tube, refrigerant leaks, etc.)

1. Recover the refrigerant from the system at the process tube located on the high side of the system by installing a line tap on the process tube. Apply the gauge from the process tube to EPA approved gauges from the process tube to the EPA approved recovery system. Recover the CFC's in the system to at least 5%.
2. Cut the process tube below the pinch off in the suction side of the compressor.
3. Connect the line from the nitrogen tank to the suction process tube.
4. Drift dry nitrogen through the system and unsolder the more distant connection first. (Filter drier, high side process tube, etc.)
5. Replace the inoperative component, and always install a new filter drier. Drift dry nitrogen through the system when making these connections.
6. Pressurize the system to 30 PSIG with proper refrigerant and boost the refrigerant pressure to 150 PSIG with dry nitrogen.
7. Leak test the complete system with the electric halogen leak detector, correcting any leaks found.
8. Reduce the system to zero gauge pressure.
9. Connect the vacuum pump to the high side and low side of the system with deep vacuum hoses, or copper tubing. (Do not use regular hoses.)
10. Evacuate the system to an absolute holding pressure of 200 microns or less.

NOTE: This procedure can be sped up by the use of heat lamps, or by breaking the vacuum with refrigerant or dry nitrogen at 5,000 microns. Pressure system to 5 PSIG and leave in the system a minimum of 10 minutes. Recover refrigerant, and proceed with evacuation to a pressure of 200 microns or a minimum of 10%.

11. Break the vacuum by charging the system from the high side with the correct amount of refrigerant specified. This will prevent boiling the oil out of the crankcase.

NOTE: If the entire charge will not enter the high side, allow the remainder to enter the low side in small increments while operating the unit.

12. Restart the unit several times after allowing pressures to stabilize. Pinch off the process tubes, cut and solder the ends. Remove the pinch off tool, and leak check the process tube ends.

SPECIAL PROCEDURES IN THE CASE OF COMPRESSOR MOTOR BURNOUT

1. Recover all refrigerant and oil from the system.
2. Remove the compressor, capillary tube and filter drier from the system.
3. Flush the evaporator, condenser and all connecting tubing with dry nitrogen, or equivalent, to remove all contamination from the system. Inspect the suction and discharge lines for carbon deposits. Remove and clean if necessary.
4. Reassemble the system, including a new drier-strainer and capillary tube.
5. Proceed with processing as outlined under hermetic component replacement.

ROTARY COMPRESSOR SPECIAL TROUBLESHOOTING & SERVICE

Basically, troubleshooting and servicing rotary compressors is the same as on the reciprocating compressor with only a few exceptions.

1. Because of the spinning motion of the rotary, the mounts are critical. If vibration is present, check the mounts carefully.
2. The electrical terminals on the rotary are in a different order than the reciprocating compressors. The terminal markings are on the cover gasket. Use your wiring diagram to insure the correct connections.

REFRIGERANT CHARGE

1. The refrigerant charge is extremely critical. Measure the charge carefully and as exactly as possible to the nameplate charge.
2. The correct method for charging the rotary is to introduce liquid refrigerant into the high side of the system with the unit off. Then start the compressor and enter the balance of the charge, gas only, into the low side.

The introduction of liquid into the low side, without the use of a capillary tube, will cause damage to the discharge valve of the rotary compressor.

NOTE: All inoperative compressors returned to Friedrich must have all lines properly plugged with the plugs from the replacement compressor.

TROUBLESHOOTING

PROBLEM	POSSIBLE CAUSE	TO CORRECT
UNIT DOES NOT RUN.	Power disconnected.	Check power source.
	System switch in "Off" position.	Set switch correctly.
	Branch circuit fuse blown or circuit breaker tripped.	Replace fuse, reset breaker. If repeats, check fuse or breaker size. Check for shorts in unit wiring and components.
	Inoperative system switch.	Test for continuity.
	Loose or disconnected wiring at switch.	Check wiring and connections. Connect per wiring diagram.
	Inoperative switch (On-Off).	Test for continuity, 3 and 2, 5 and 6.
EVAPORATOR COIL FREEZES UP.	Dirty Filter.	Clean as recommended in Owner's Manual.
	Restricted air flow.	Check for dirty or obstructed coil - clean as required.
	Inoperative thermostat.	Test for shorted thermostat or stuck contacts.
	Short of refrigerant.	De-ice coil and check for leak.
	Partially restricted capillary.	De-ice coil. Check temperature differential across coil. Touch test coil return bends for same temperature. Test for low running current.
	Inoperative fan motor.	Test and replace if inoperative.
COMPRESSOR RUNS CONTINUALLY. DOES NOT CYCLE OFF.	Excessive heat load.	Test cooling performance of unit. Unit undersized.
	Restriction in line.	Check for partially iced coil. Check temperature split across coil.
	Refrigerant leak.	Check for presence of oil on silver soldered connections. Check for partially iced coil. Check split across coil. Check for low running amperage.
	Thermostat contacts stuck.	Check operation of thermostat. Replace if contacts remain closed.
THERMOSTAT DOES NOT TURN UNIT ON.	Loss of charge in thermostat bulb.	Place jumper across thermostat terminals. If unit operates, replace thermostat.
	Loose or broken parts in thermostat.	Check as above.
	Incorrect wiring.	Connect per wiring diagram.
	System switch open.	Test for continuity at switch terminals 2 and 3.
THERMOSTAT DOES NOT TURN UNIT OFF.	Thermostat set at coldest point	Turn to highest temperature setting to see if unit will cycle off.
	Thermostat contacts stuck.	Disconnect power to the unit. Remove cover of thermostat and check if contact is stuck, if so replace thermostat.
	Switch (On - Off) shorted.	Test switch for open contacts at terminals 2 and 3 with switch in "Off" position.

TROUBLESHOOTING (Continued)

PROBLEM	POSSIBLE CAUSE	TO CORRECT
COMPRESSOR ATTEMPTS TO START, OR RUNS FOR SHORT PERIODS ONLY. CYCLES ON OVERLOAD.	Compressor attempts to start before system pressures are equalized.	Allow a minimum of two (2) minutes to allow pressures to equalize before attempting to start.
	Low or fluctuating voltage.	Check voltage with unit operating. Check for other appliances on the circuit. Unit should be on separate circuit for proper voltage, and be fused separately.
	Incorrect wiring.	Connect per wiring diagram.
	Shorted or incorrect capacitor.	Check by substituting a known good capacitor of correct rating.
	Restricted or low air flow through condenser coil.	Check for proper fan speed or blocked condenser.
	Compressor running abnormally hot.	Check for kinked discharge line or restricted condenser. Check amperage.
	Overload opens too soon.	Change compressor if all other corrections above are normal.
COMPRESSOR DOES NOT START - FAN MOTOR RUNS.	Thermostat contacts not closing.	Check continuity of thermostat at coldest setting. Jump contacts, if compressor runs, replace thermostat.
	Low voltage supply.	Check for nameplate voltage.
	Switch (On-Off) inoperative.	Test for continuity.
	Open capacitor.	Check by substituting a known good capacitor of correct rating.
	Internal overload open.	Check voltage at compressor terminals. If voltage is satisfactory, replace compressor.
	Relay open	Replace relay
	Open or shorted compressor windings	Check windings for continuity and resistance. Direct test compressor. If direct test fails, replace compressor.
DOES NOT COOL, OR COOLS ONLY SLIGHTLY.	Thermostat open or inoperative.	Set to coldest position. Test thermostat and replace if necessary.
	Dirty air filter.	Clean as recommended in Owner's Manual.
	Dirty or plugged condenser or evaporator coil.	Use steam or detergents to clean.
	Poor air circulation in area being cooled.	Adjust air louvers.
	Low capacity - undercharge.	Clean, check for leak and make repair.
	Compressor not pumping properly.	Check amperage draw against nameplate. If not conclusive, make pressure test.

TROUBLESHOOTING (Continued)

PROBLEM	POSSIBLE CAUSE	TO CORRECT
FAN MOTOR DOES NOT RUN.	Defective switch (On-Off).	Check continuity across terminals 2 and 3.
	Fan capacitor open.	Check by substituting a known good capacitor of the same rating.
	Inoperative fan motor.	Direct test fan motor.
	Incorrect wiring of fan circuit.	Connect per wiring diagram.
	Relay open.	Replace Relay.
	Check for seized motor bearings.	Rotate by hand, add oil, if noisy, replace.
	Bound fan blade or blower wheel.	Adjust for proper clearance.
SWITCH (ON-OFF) DOES NOT CUT FAN MOTOR OFF.	Selector Switch Relay	Replace selector switch. Replace relay.
NOISY AND/OR VIBRATION.	Poor installation.	Refer to Installation Instructions for proper installation.
	Fan blade striking chassis.	Adjust motor mount to attain proper fan blade and blower wheel clearance.
	Compressor vibrating.	Check for deteriorated compressor grommets, or missing mounting parts.
	Loose cabinet parts, improperly mounted components, tubing rubbing.	Adjust and tighten as required.
WATER LEAKS INTO ROOM.	Evaporator drain pan overflowing.	Clean obstructed drain trough.
	Condensation forming on bottom of base pan.	Evaporator drain pan broken or cracked. Reseal or replace.
	Water dripping from discharge air grilles.	Dirty evaporator coil, or extremely high humidity conditions. Clean coil with steam or detergent.
OUTSIDE WATER LEAKS.	Evaporator drain pan cracked or obstructed.	Repair and clean, or replace as required.
	Water in center section of base pan (compressor area).	Remove condenser shroud, Clean and remove old sealer from base pan and shroud. Apply new sealer, reinstall and check.
	Dirty Condenser coil.	Clean with steam or detergent.
	Fan blade and slinger ring improperly positioned.	Adjust fan blade to 1/2" clearance from condenser coil.

WIRING DIAGRAM MODELS SH15L30-B and SH20L30-B

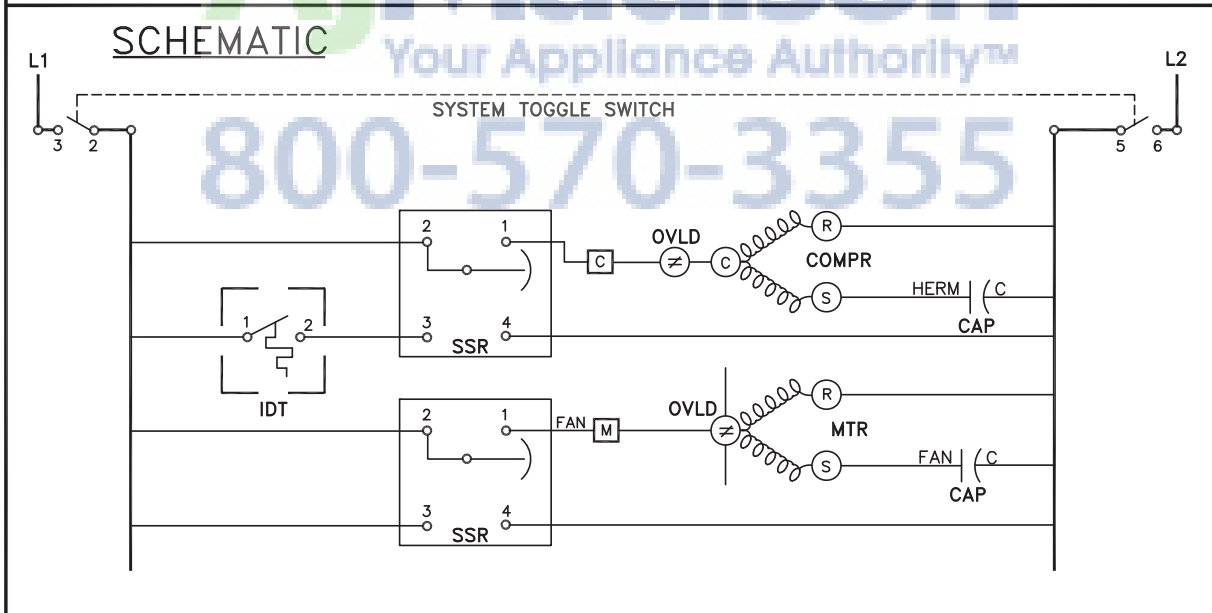
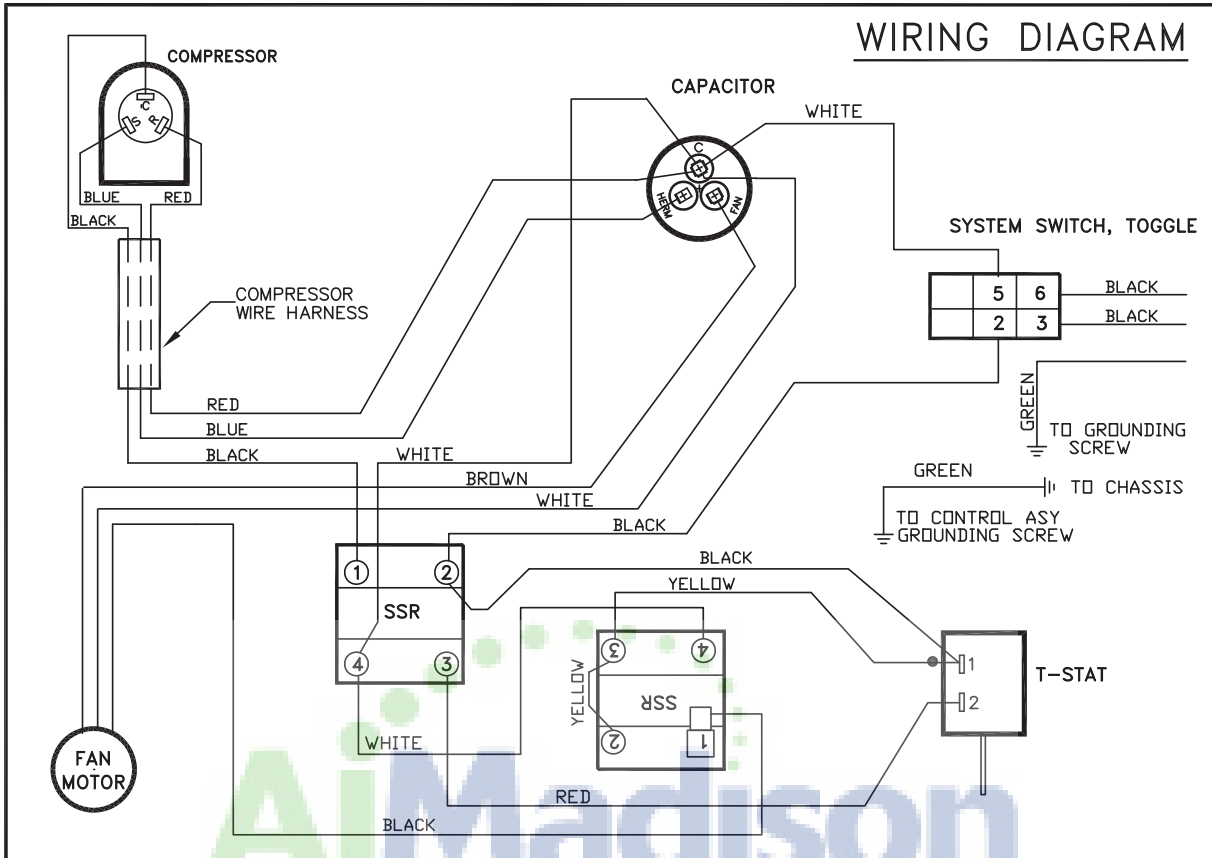

LEGEND

<p>SSR - SOLID STATE RELAY CAP - CAPACITOR COMPR - COMPRESSOR MTR - FAN MOTOR OVL - OVERLOAD PROTECTOR SYS SW - SYSTEM SWITCH IDT - INDOOR THERMOSTAT</p>	<p> - TERMINAL ADAPTER - GROUND LEAD - COMBINATION TERMINAL</p>
---	---

PART NO. 619-405-08	REV. 02
------------------------	------------

HAZARDGARD CABINET PARTS

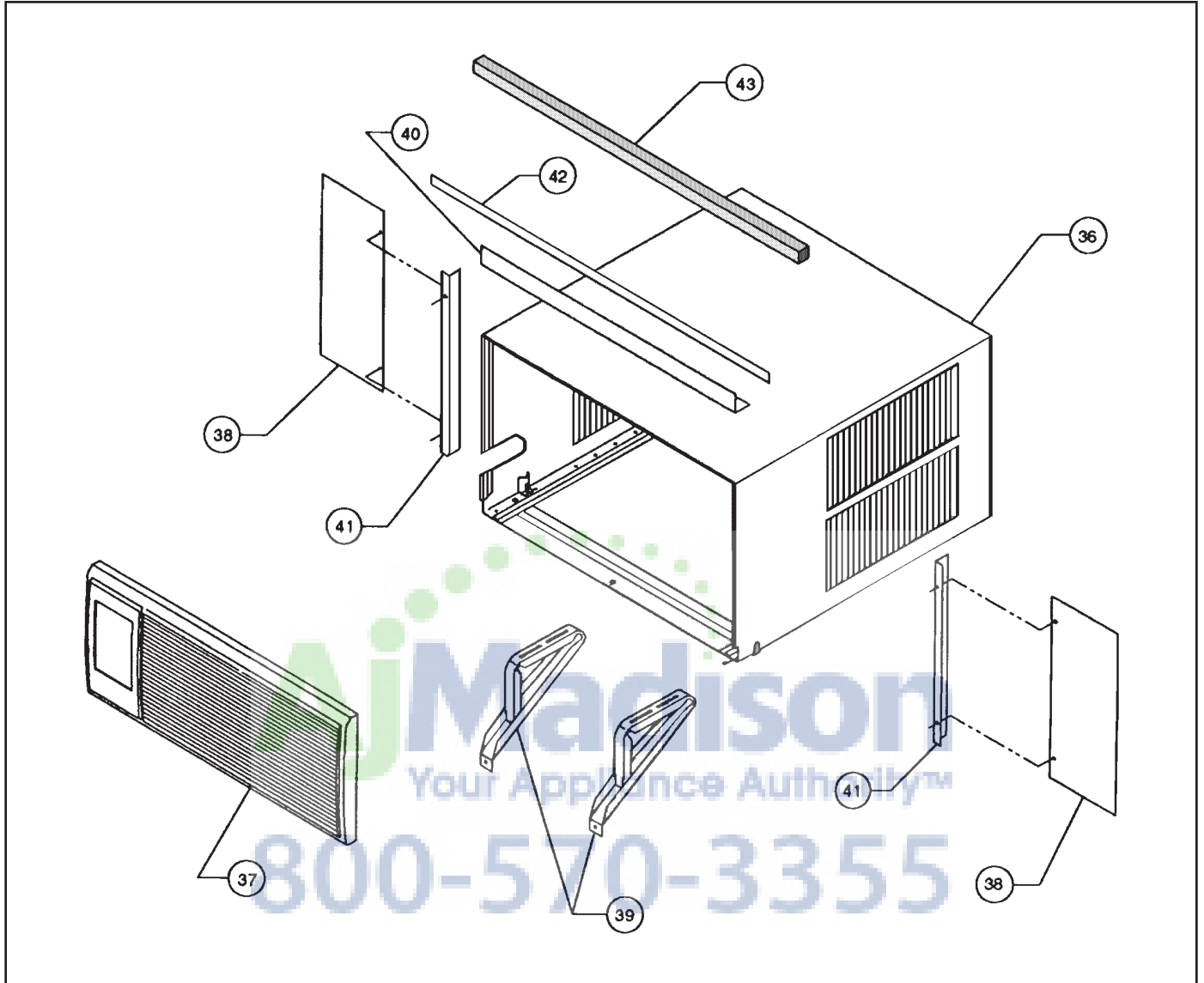

HAZARDGARD CHASSIS PARTS

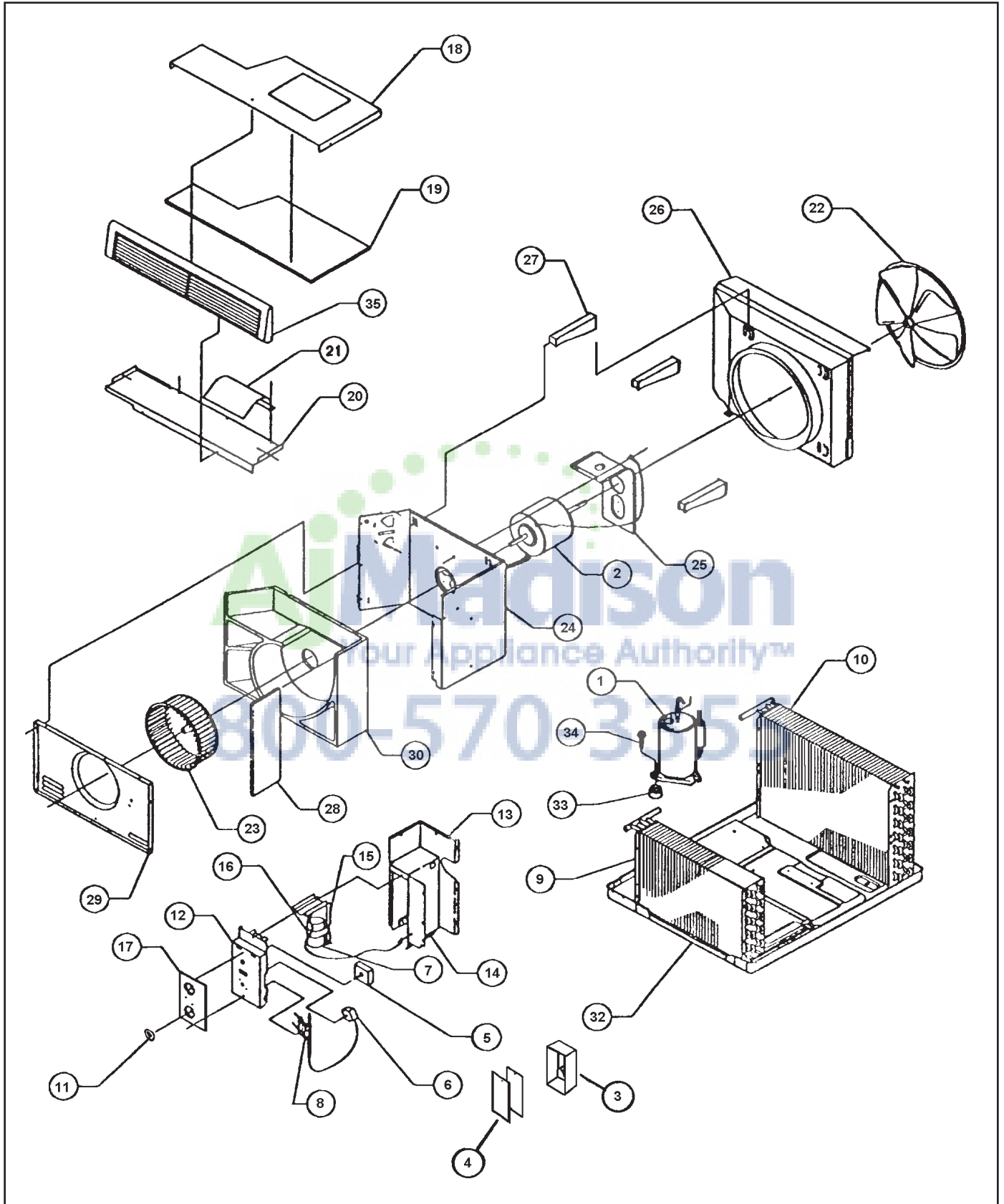

HAZARDGARD PARTS LIST

REF	DESCRIPTION	PART NO#	MODELS		CODE
			SH15L30-B	SH20L30-B	
ELECTRICAL PARTS					
1	COMPRESSOR	61193549	1		600
1	COMPRESSOR	61193550		1	600
2	MOTOR, FAN	61871426	1		110
2	MOTOR, FAN	61871427		1	110
5	SWITCH, ON-OFF DPST	60935300	1	1	130
*	INSULATOR, ELECTRICAL	61829700	1	1	399
*	RELAY, SOLID STATE	61108800	2	2	399
6	THERMOSTAT	61822502	1	1	120
7	CAPACITOR 20/7.5 440 V.	61080546	1		150
7	CAPACITOR 25/7.5 440 V	61080547		1	150
*	HARNESS, WIRE, COMP.	61821308	1	1	399
REFRIGERATION PARTS					
			SH15L30-B	SH20L30-B	
9	EVAPORATOR COIL	61850100	1		400
9	EVAPORATOR COIL	61850001		1	400
10	CONDENSER COIL	62050410	1		410
10	CONDENSER COIL	62050411		1	410
*	DRIER, LIQUID	60308101	1	1	480
*	CAPILLARY TUBE	01390005	1		471
*	CAPILLARY TUBE	03760518		2	471
*	VALVE, BY-PASS	60809500	2		520

HAZARDGARD PARTS LIST

REF	DESCRIPTION	PART NO#	MODELS		CODE
			SH15L30-B	SH20L30-B	
CHASSIS PARTS					
8	HOLDER, THERMOSTAT	61829800	1	1	999
11	KNOB, CONTROL	61493915	1	1	761
17	DECORATIVE PANEL	61822662	1	1	760
22	FAN BLADE, COND.	60542003	1		710
22	FAN BLADE, COND.	60542004		1	710
23	BLOWER WHEEL, EVAP.	60610616	1		700
23	BLOWER WHEEL, EVAP.	60610617		1	700
25	FAN MOTOR MOUNT	61802500	1		900
25	FAN MOTOR MOUNT	61804100		1	900
26	SHROUD, CONDENSER	61803601	1		720
26	SHROUD, CONDENSER	61804901		1	720
27	BRACE, COND.SHROUD	61802600	3	3	722
29	BLOWER FRONT	61817300	1		742
29	BLOWER FRONT	61817400		1	742
30	SCROLL	61814905	1		743
30	SCROLL	61817505		1	743
32	BASE PAN	61803444	1	1	730
34	BOLT, COMP. MOUNT	91400400	3	3	791
35	PLENUM ASSEMBLY	61831006	1	1	753
36	OUTER SHELL	61825708	1		770
36	OUTER SHELL	61825709		1	770
37	GRILLE, INTAKE	61808906	1		772
37	GRILLE, INTAKE	61811111		1	772
38	WINGBOARD	60294415	1		999
38	WINGBOARD	60294420		1	999
40	ANGLE, WINGBOARD TOP	61819711	1	1	999
41	ANGLE, WINGBOARD SIDE	61819811	2	2	999
*	LATCH, INTAKE GRILLE	61989000	2	2	752
*	FILTER, AIR	60865808	1		754
*	FILTER, AIR	60865809		1	754
*	HOLDER, FILTER	61823000	2	2	756
*	DRAIN PAN, EVAP.	61803800	1	1	840
*	GROMMET, COMP. MOUNT	01193549	3	3	790
*	REAR GRILLE	61818500	1		771
*	REAR GRILLE	61818501		1	771
*	BAG, ASSY. HARDWARE	60846016	1	1	999
*	GASKET, CHASSIS	61717301	1	1	780
OPTIONAL ACCESSORY ITEMS					
*	DRAIN KIT, DC-2	01900235	1	1	
*	START KIT, CAP.RELAY	01900312	1	1	



Friedrich Air Conditioning Company
P.O. Box 1540
San Antonio, TX 78295
210.357.4400
www.friedrich.com

HAZARDGARD® ROOM AIR CONDITIONERS LIMITED WARRANTY

LIMITED ONE YEAR PARTS WARRANTY

1. Limited warranty – One year. Friedrich warrants that it will provide a replacement for any part of this HazardGard Room Air Conditioner found defective in material or workmanship for a period of one (1) year from the date of original purchase.

2. Limited warranty – One year. The Friedrich warranty also covers the cost of labor for repairing any compressor, condenser, evaporator or inter-connecting tubing found defective within the warranty period, providing the unit is returned to an authorized Friedrich Repair Station located within the Continental United States.

The Friedrich warranty does not cover:

(1) Any charges for removal, transportation or reinstallation of the unit; (2) the cost of labor to replace parts other than those described above; and (3) does not apply to any HazardGard Room Air Conditioner that has been subject to (a) accident, misuse, flood, fire, or neglect; (b) repairs or alterations outside of the Friedrich Authorized Dealer or Service Center so as to affect adversely its performance and reliability; or (c) any repairs or servicing as a result of using parts not sold or approved by Friedrich.

LIMITATIONS: This warranty is a LIMITED warranty. Anything in the warranty notwithstanding, IMPLIED WARRANTIES FOR PARTICULAR PURPOSE AND MERCHANTABILITY SHALL BE LIMITED TO THE DURATION OF THE EXPRESS WARRANTY. MANUFACTURER EXPRESSLY DISCLAIMS AND EXCLUDES ANY LIABILITY FOR CONSEQUENTIAL OR INCIDENTAL DAMAGES FOR BREACH OF ANY EXPRESSED OR IMPLIED WARRANTY.

800-570-3355

(10-04)



FRIEDRICH AIR CONDITIONING CO.
Post Office Box 1540 · San Antonio, Texas 78295-1540
4200 N. Pan Am Expressway · San Antonio, Texas 78218-5212
(210) 357-4400 · FAX (210) 357-4480
www.friedrich.com

Printed in the U.S.A.

HG-SVC-PRTS-07 (3-07)