

30" Electric Freestanding Range 500 Series - Stainless Steel HES5053U



Features and Benefits

Key Features

- Convection Saves Time and Energy. A Fan Provides Even Heat Distribution Throughout the Cavity for Superiour Cooking Results
- PowerBoil - Quick Heating with Powerful 3,000 W Element.
- Extra Large 12 Inch Element Offers the Capablity to Use Multiple Pan Sizes
- Dual Element offers the Capability to use Multiple Pan Sizes

Design

- Design Fits to Bosch Family Look.
- Recommended Companion to other Bosch 500 Series Products.

Performance

- Convection Saves Time and Energy. A Fan Provides Even Heat Distribution Throughout the Cavity for Superiour Cooking Results
- PowerBoil - Quick Heating with Powerful 3,000 W Element.
- Extra Large 12 Inch Element Offers the Capability to Use Multiple Pan Sizes
- 100W Warming Zone - Perfect for Keeping Food Ready to Serve or Prewarming Dishes.
- Dual Element Offers the Capability to use Multiple Pan Sizes.

Convenience

- Two Racks and Seven Different Rack Positions Adjust for All Cooking Needs.
- Self Clean Cycle Saves Time. Quickly and Easily Cleans your Oven.
- Wide View Oven Window - Extra large Window Provides Easy Viewing of Your Food.
- True Hidden Bake Element

Capacity

- Large Cavity with 5.4 cu ft. Easily Accomodates Large Dishes and Offers Multiple Rack Cooking.

Notes: All height, width and depth dimensions are shown in inches. *Please refer to installation instructions prior to making cutout. BSH reserves the absolute and unrestricted right to change product materials and specifications, at any time, without notice. Consult the product's installation instructions for final dimensional data and other details. Applicable product warranty can be found in a ccompanying product literature or you may contact your account manager for further details.

For more information on our entire line of products, go to boschappliances.com or call 1-800-944-2904.
Copyright ©2014 BSH Home Appliances Corporation. All rights reserved. Bosch is a registered trademark of Robert Bosch GmbH.

Litho Date: 03/2014



30" Electric Freestanding Range 500 Series - Stainless Steel HES5053U

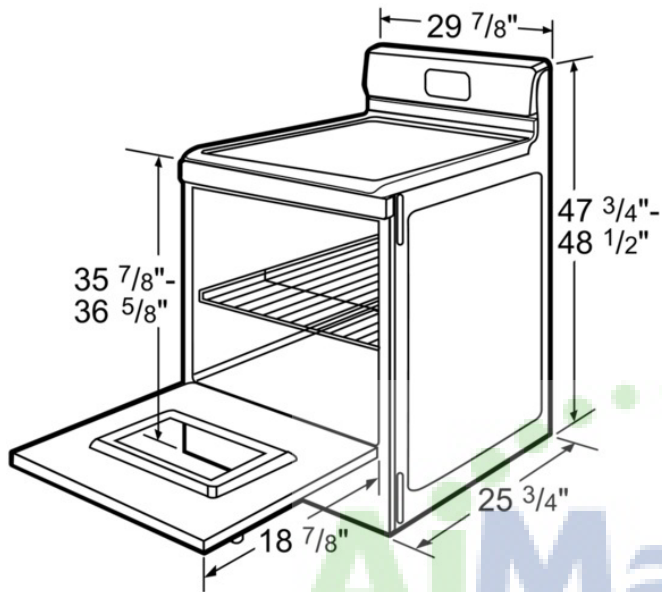

Dimensions in inches

Features

Total number of cooktop burners	5
Cooking method primary cavity	Convection Bake, Conventional heat, Half width variable grill
Cleaning system - primary cavity	Self Clean
Oven Control	electrical
Knob Material	Plastic
Included accessories	2 x grid
Sealed Burners	No
Number of Double grates	
Bake Element Wattages primary cavity (W)	3500
Broil Element Wattages primary cavity (W)	3600
Convection Element Wattages primary cavity (W)	
Number of gas burners	0
Location of 1st heating element	front left
Power of 1st burner (BTU)	
Location of 2nd heating element	back left
Power of 2nd burner (BTU)	
Location of 3rd heating element	middle back
Power of 3rd burner (BTU)	
Location of 4th heating element	back right
Power of 4th burner (BTU)	
Location of 5th heating element	front right
Power of 5th burner (BTU)	
Location of 6th heating element	
Power of 6th burner (BTU)	
Power of griddle element	
Display	7-segment, red
Safety device	

Technical Specification

UPC code	825225880875
Product color	Stainless steel
Gas type	
Alternative gas type	
Total BTU load	
Watts (W)	9500
Current (A)	40
Volts (V)	240/208
Frequency (Hz)	60
Approval certificates	UL
Required cutout size (HxWxD) (in)	30" width slide-in
Overall appliance dimensions (HxWxD) (in)	47 3/4" x 29 7/8" x 25 3/4"
Variable cooker height (in)	3/4"
AHAM usable cavity size	
Product packaging dimensions (HxWxD) (in)	50" x 32" x 29 1/2"

Notes: All height, width and depth dimensions are shown in inches. *Please refer to installation instructions prior to making cutout. BSH reserves the absolute and unrestricted right to change product materials and specifications, at any time, without notice. Consult the product's installation instructions for final dimensional data and other details. Applicable product warranty can be found in a accompanying product literature or you may contact your account manager for further details.

For more information on our entire line of products, go to boschappliances.com or call 1-800-944-2904.

Copyright ©2014 BSH Home Appliances Corporation. All rights reserved. Bosch is a registered trademark of Robert Bosch GmbH.

Litho Date: 03/2014

