

24" Single 2.0 Cubic Foot Left Swing True European Convection Oven

HCW225LAES



Available Q3 2015

Unit Specifications

| | |
|--------|--------------|
| Width | 23.3/8" |
| Depth | 24.1/8" |
| Height | 23.1/8" |
| Weight | 72 lb. |
| UPC | 688057374048 |

More Easy-To-Use Features

- Stainless Steel Finish
- My Favorite Recipe Menu Option
- 1,100W Concealed Bake Element
- Halogen Interior Lighting
- 2,100W Broil Element
- Glass-Touch Electronic Controls
- Enameled Baking Pan Included

Warranty

- 2 Year Warranty (Parts and Labor)

Available Finishes



Stainless Steel

Signature Features

True European Convection

Includes a rear fan and a third 1,960-watt heating element to distribute hot air throughout the oven for faster, more even baking

LCD Display with Sensor Touch Control

Allows faster, more intuitive oven operation

Two Racks and Baking Pan with Five Shelf Positions

Offers versatility to accommodate a variety of cookware

Ten Cooking Modes

Bake, High Broil, Convection Broil, Convection Bake, True European Convection, Convection Roast, Pizza Low Broil, Multi-Cooking, and Defrost

| Letter | Cutout Dimension | in. |
|--------|------------------------|-----------|
| A | Cutout Width | 21 31/32" |
| B | Cutout Depth | 24" |
| C | Cutout Height | 22 19/32" |
| D | Floor Bottom of Cutout | 34" |
| E | Minimum Spacing | 1/2" |

Overall Packaging Details

| Packaging | lb./in. |
|--------------|---|
| Gross Weight | 82 lb. |
| Dimensions | W 25.47" D 25.91" H 25.98" |

Power Requirements

| | |
|-----------------------|-----------------|
| Electrical Rating | 208/240V, 60Hz |
| Total Electrical Load | 3.42kW / 14Amps |

Product Technical Illustration

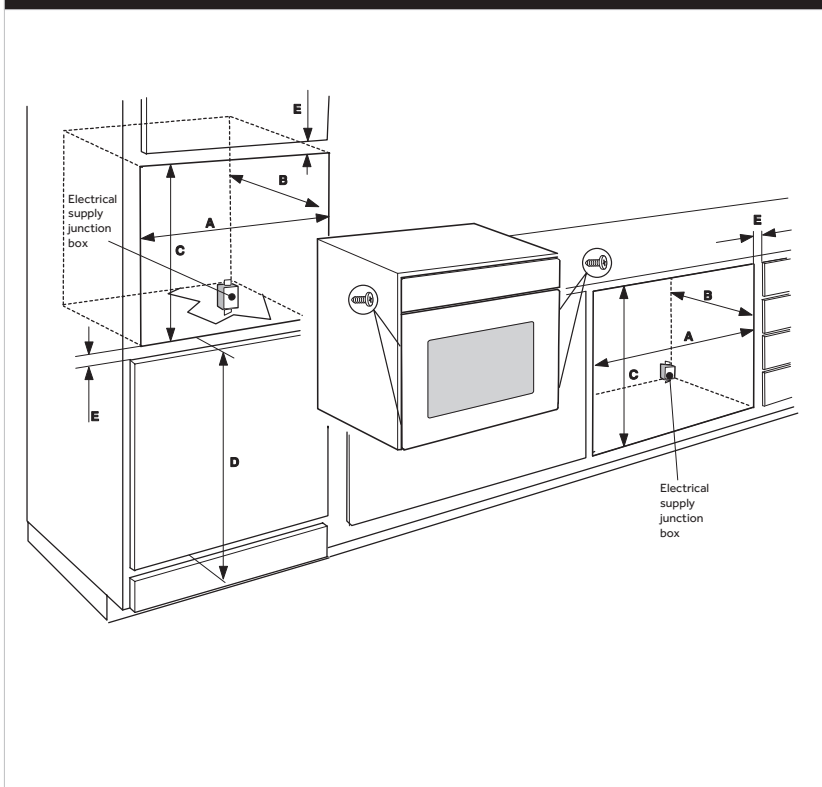

General Appliance Information

Please read all installation details and instructions before use.

Contact Us

For questions regarding this product please refer to our website at haier.com or call our customer service center at 877-337-3639.

