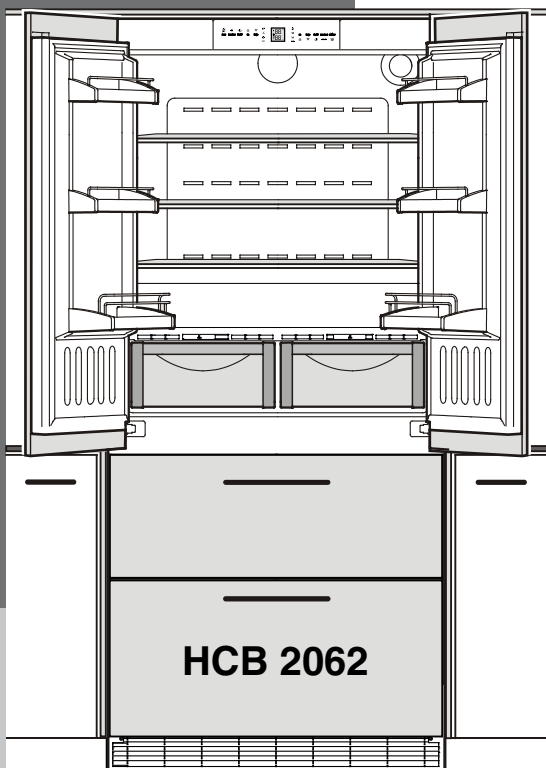
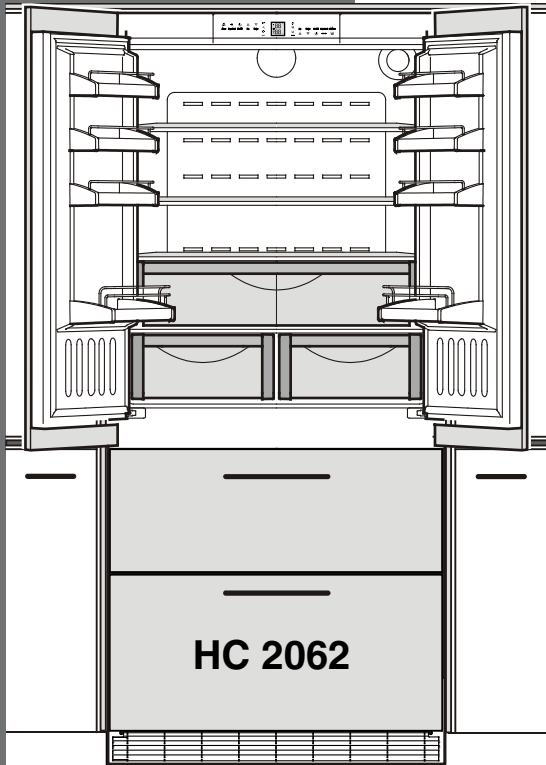


# LIEBHERR

## Installation Instructions

For Fully Integrated NoFrost  
Combined Refrigerator-Freezers



HC/HCB 2062

7084 445-00

# IMPORTANT

## Please read and follow these instructions

These instructions contain Danger, Warning and Caution statements. This information is important for safe and efficient installation and operation.

Always read and follow all Danger, Warning and Caution statements!



### DANGER!

**Danger indicates a hazard which will cause serious injury or death if precautions are not followed.**



### WARNING!

**Warning indicates a potentially hazardous situation which, if not avoided, could result in death or serious injury.**



### CAUTION!

**Caution indicates a potentially hazardous situation which, if not avoided, may result in minor or moderate injury.**

### IMPORTANT

*This highlights information that is especially relevant to a problem-free installation and operation.*

## To the installer

It is very important that the guidelines and instructions are followed in the manual to ensure proper installation and operation of the unit.

The Installation Guidelines section contains important information for making sure the installation is correct.

Read and understand all the information in Installation Guidelines and in this manual before the unit is installed.

## Contents

## Page

Unit dimensions .....	4
Unit Venting.....	4
Cabinet opening dimensions.....	5
Panel Dimensions - Framed Cabinet Design .....	6
Panel Dimensions - Frameless Cabinet Design.....	7
Mounting the anti - tipping device on concrete floors...	8
Mounting the anti - tipping device on wooden floors....	8
Mounting the anti tipping device at cabinets deeper than 24" .....	9
Cover strips .....	9
Ice Maker	
Safety instructions and warnings .....	10
Water connection.....	10
Connection to the water supply.....	10
Leveling the Refrigerator .....	12
Adjusting the front of the drawer .....	12
Fasten the appliance in the recess.....	12
Before mounting the door panels.....	12
Mounting the attachment brackets onto the door panels .....	13
Mounting the freezer drawer panels.....	14
Mounting the refrigerator door panels .....	14-17
Mounting the ventilation grille.....	17

## R600a refrigerant

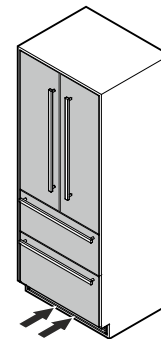


### WARNING!

**The refrigerant contained within the appliance R600a is environmentally friendly, but flammable. Leaking refrigerant can ignite.**

**To prevent possible ignition follow the warnings below:**

- **Keep ventilation openings, in the appliance enclosure or in the built-in structure, clear of obstruction.** →
- **Do not damage the refrigerant circuit.**
- **Any repairs and work on the appliance should only be performed by the customer service department.**



# INSTALLATION GUIDELINES

## Disposal of old appliance



**DANGER!**

### Risk of child entrapment.

Child entrapment and suffocation are not problems of the past.

Junked or abandoned refrigerators are still dangerous – even if they will sit for “just a few days.”

If you are getting rid of your old refrigerator, please follow these instructions to help prevent accidents.

### Before you discard old appliances:

- Remove the doors.
- Leave the shelves in place so that children may not easily climb inside.
- Cut off the power cable from the discarded refrigerator. Discard separately from the refrigerator.
- Be sure to follow your local requirements for disposal of appliances.

Contact the trash collection agency in your area for additional information.

## Disposal of carton

The packaging is designed to protect the appliance and individual components during moving and is made of recyclable materials.



**WARNING!**

Keep packaging materials away from children. Polythene sheets and bags can cause suffocation!

Please recycle packaging material where facilities are available.

## Electrical safety

Connect this appliance to a 15 amp or 20 amp, 110-120 VAC, circuit which is grounded and protected by a circuit breaker or fuse.

We recommend using a dedicated circuit for this appliance to prevent circuit overload and the chance of interruption to the appliance.

This appliance is equipped with a three-prong (grounding) polarized plug for your protection against possible shock hazards.

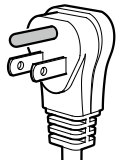
Where a two-prong wall receptacle is encountered, contact a qualified electrician and have it replaced with a properly grounded three-prong receptacle in accordance with all local codes and ordinances.

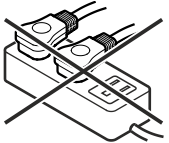


**WARNING!**

Electrocution hazard.

Electrical grounding required.

- Do not remove the round grounding prong from the plug. 
- Do not use extension cords or ungrounded (two prong) adapters.
- Do not use a power cord that is frayed or damaged.

- Do not use a power strip. 

Failure to follow these instructions may result in fire, electrical shock or death.

## Blocking for Safety

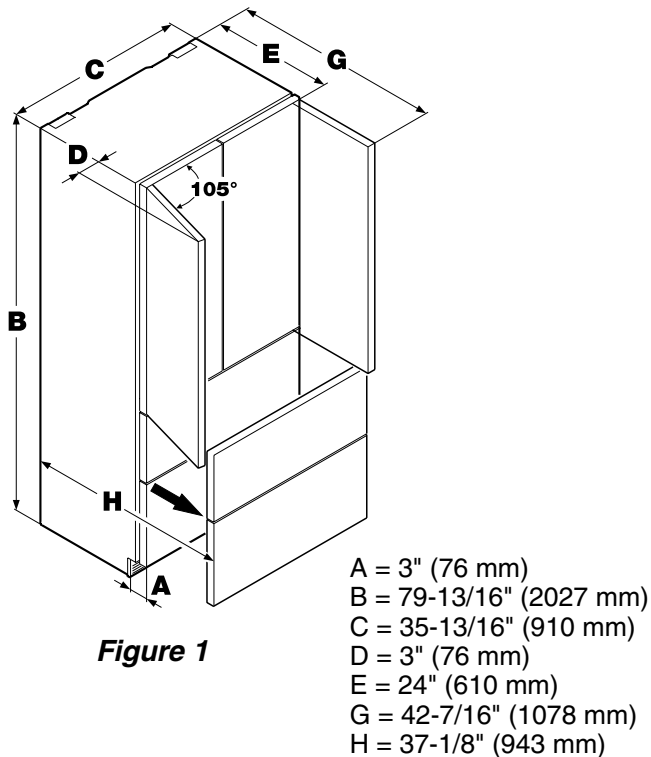


**WARNING!**

To avoid a hazard due to instability of the appliance, it must be fixed in accordance with the instructions.

# PLANNING INFORMATION

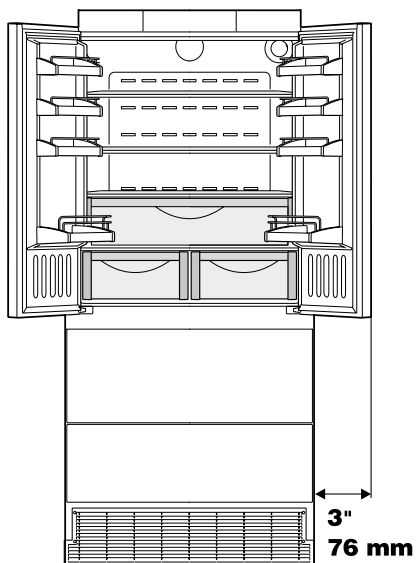
## Unit Dimensions - Figure 1



## Door swing clearance - Figure 2

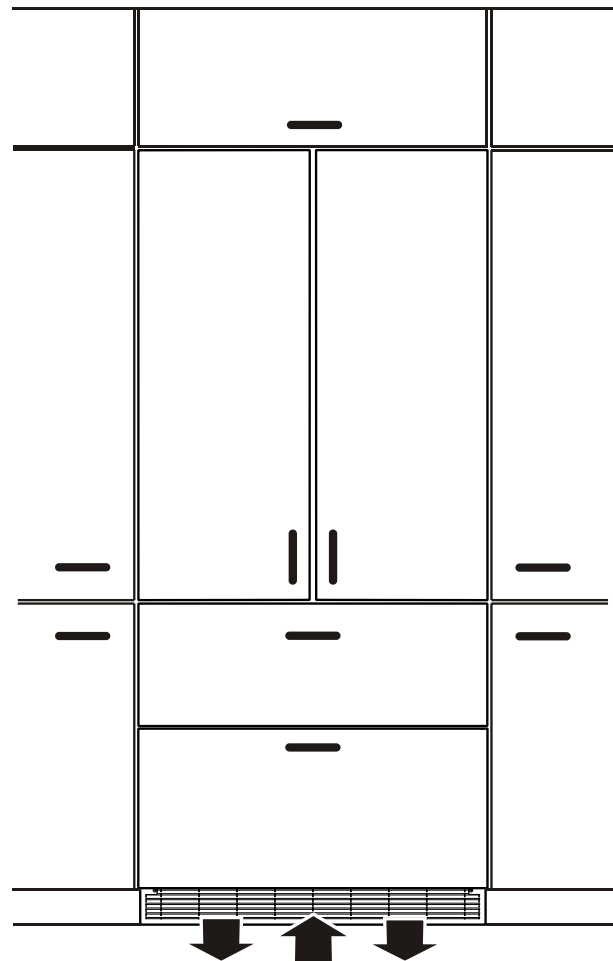
Please allow for door swing clearance at locations next to a wall.

The illustrated measurement is without mounted front panels. Be sure to add your panel thickness and handle depth to this measurement in order to avoid interferences.



## Unit Venting - Figure 3

HC/HCB 20 appliances do not require any ventilation openings in the cabinet. The required airflow is directed through the toe kick area.



It is important to use the provided cover grille for the ventilation opening. This opening must not be covered with a cabinet base.

# PLANNING INFORMATION

## Cabinet Opening Dimensions - Figure 4

Cabinet Height <b>C</b>	Inset cabinet Depth <b>B</b>	Frameless/faceframe cabinet Depth <b>B</b>
80"	24" + panel thickness	24"
84"	24" + panel thickness	24"

For appliance with panel to be flush, adjacent cabinetry depth must equal appliance depth (24") plus panel thickness (5/8" - 3/4").

**IMPORTANT**  
Do not install the shut-off valve behind the appliance.

The position of the electrical outlet is possible within the grey shaded areas or above the appliance.

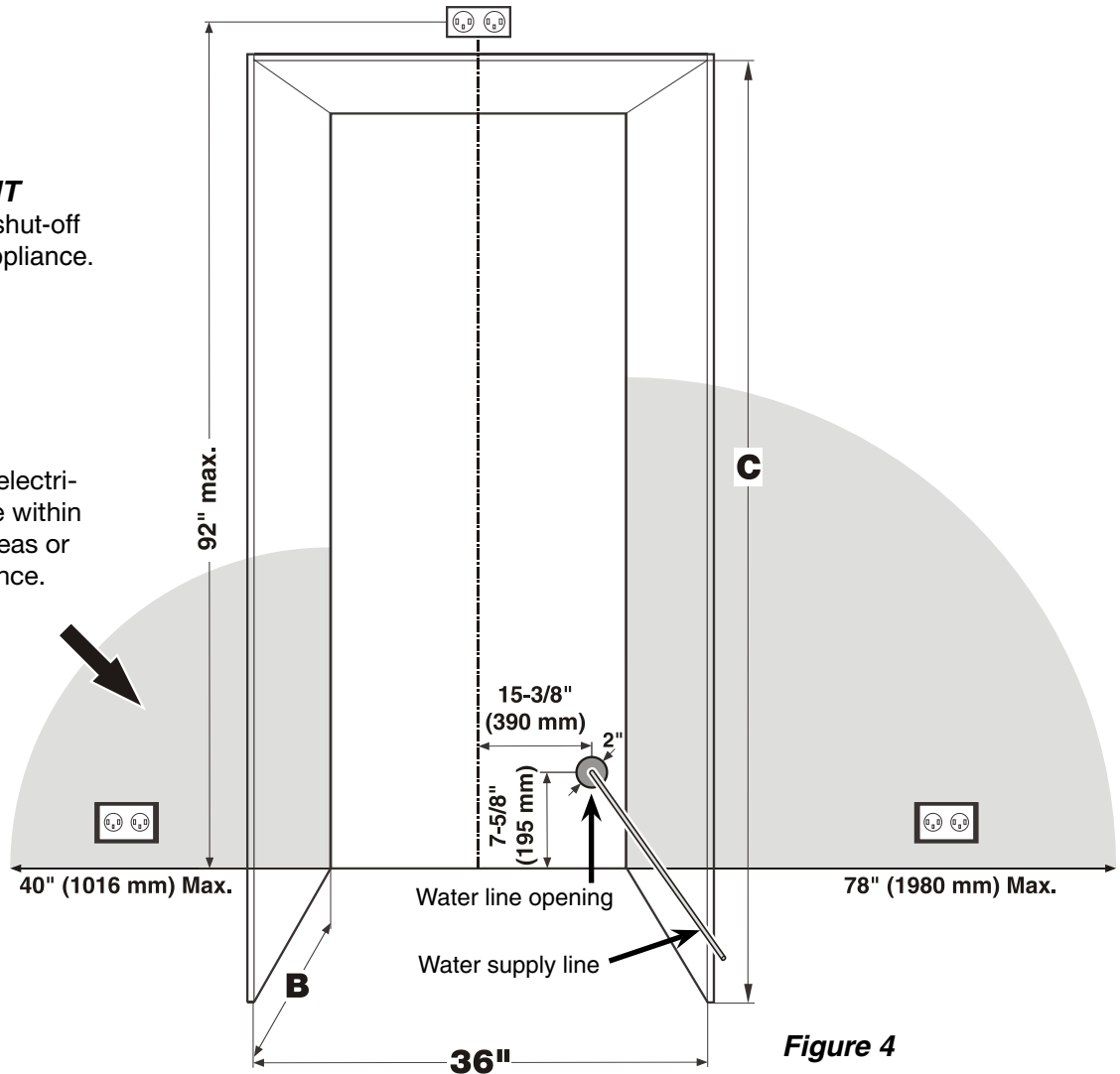


Figure 4

**IMPORTANT**  
For 24" cabinets, the water line opening must be in the location as shown in **Figure 4**.

With cabinets deeper than 24", there is room to fit the pipe behind the appliance and the wall so there are no requirements for the water line lead out position.

**IMPORTANT**  
The free length of the water supply line must be at least 31-1/2" (800 mm) when the tube comes out of the prescribed opening.

# PLANNING INFORMATION

## Panel Dimensions - Inset Installation Style - Figure 5

Appliance and panels sit fully within the opening and are flush with what could be its own box, between two pantry cabinets or decorative columns, etc. This is the most common installation scenario.

The panels should be at least 5/8 inch (16 mm) thick to allow the connecting rails to be fastened to them.

**IMPORTANT**

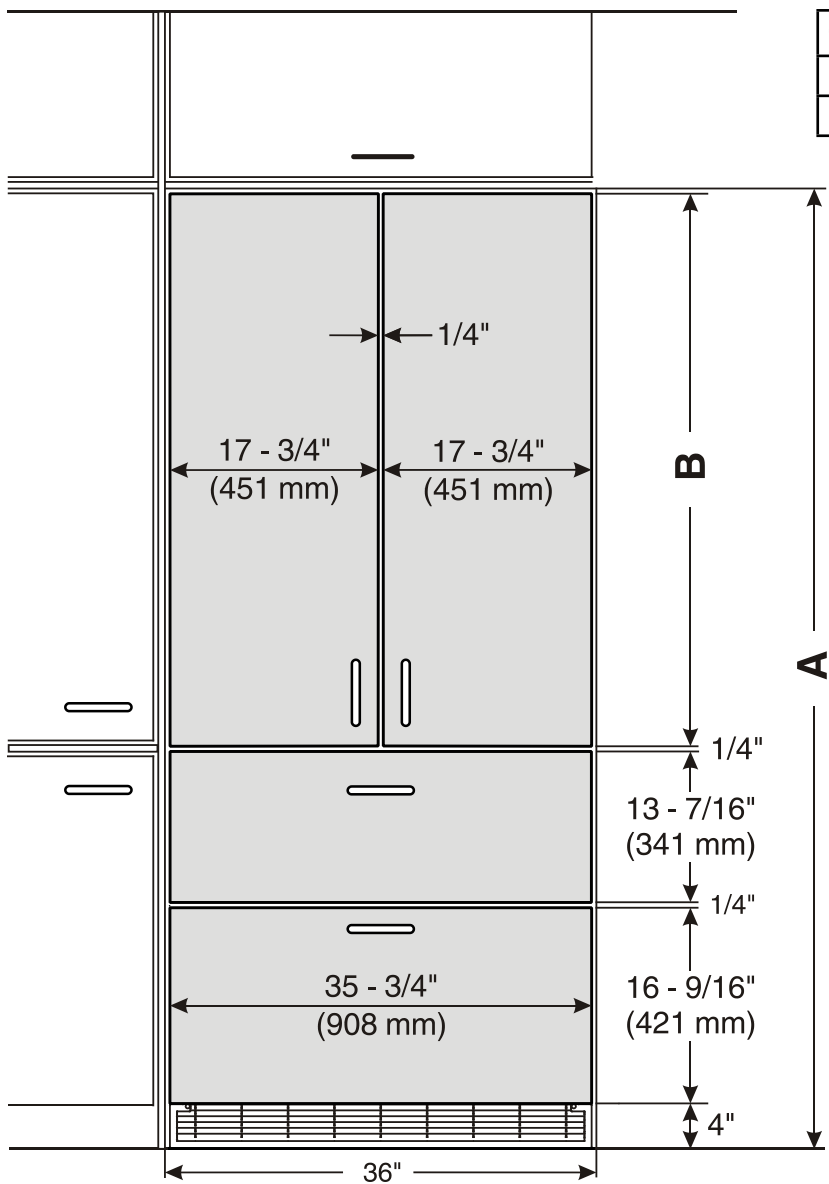
The maximum panel thickness is 3/4" (19 mm).

**You can order stainless steel panels for inset installation style.**

Refrigerator door panels 80"- article-number 9900 337-00

Refrigerator door panels 84"- article-number 9900 335-00

Freezer drawer panels - article-number 9900 323-00



Cabinet Opening <b>A</b>	Refrigerator door panel <b>B</b>
80" (2032 mm)	45 - 1/4" (1150 mm)
84" (2134 mm)	49 - 1/4" (1251 mm)

**Figure 5**

# PLANNING INFORMATION

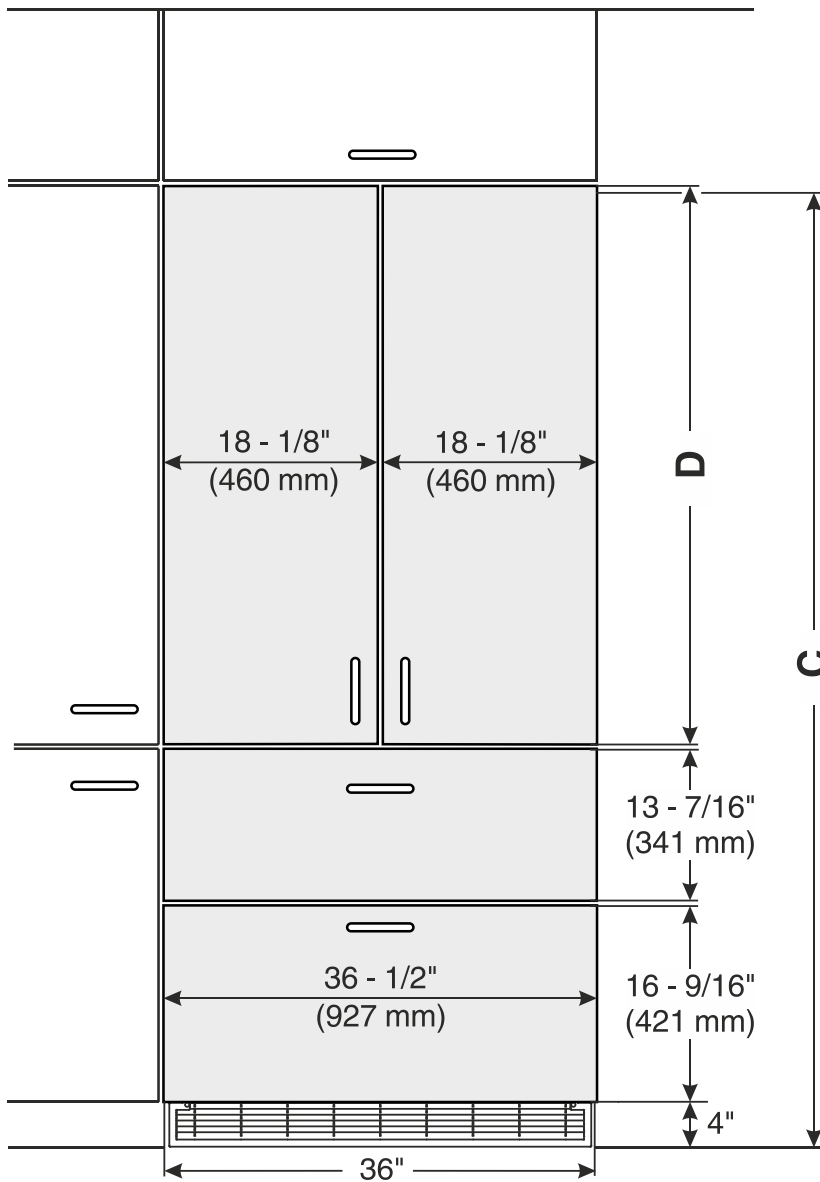
## Panel Dimensions - Frameless Installation Style - Figure 6

With this installation style, these wider appliance panels partially overlay the shared side gables of adjacent cabinetry so as to mimic the look of a frameless style cabinet.

The gap between panels with frameless installation style is 1/4" (6 mm). The panels should be at least 5/8 inch (16 mm) thick to allow the connecting rails to be fastened to them.

### IMPORTANT

The maximum panel thickness is 3/4" (19 mm).



Cabinet Opening C	Refrigerator door panel D
80" (2032 mm)	45 - 3/4" (1162 mm)
84" (2134 mm)	49 - 3/4" (1264 mm)

Figure 6

# BLOCKING FOR SAFETY

## Mounting the anti tipping device on concrete floors - Figure 7 - 8

Secure the appliance in place so it does not tip forward when the fully stocked door is opened. The anti tipping bracket is provided with the appliance.

1. Mark the center line of the appliance on the back wall. Align the anti tipping bracket center to this line.

### ⚠ WARNING

Be sure that there is no plumbing or electrical wiring located in this area which screws or drills could damage.

2. Drill a 3/8" diameter hole in any position as shown in **Figure 7** using a carbide drill bit.

The depth of the holes must exceed the overall length of the anchors provided.

Clean the holes after drilling.

3. Attach washer and screw on hex nut to the end of each anchor.

Drive in all 3 anchors.

Align the bracket center to the center line on the back wall again.

Fasten the anchors by turning the hex nut.

4. Fasten bracket with 3 screws (1/4" x 2-1/8") into the wall plate (**Figure 8**).

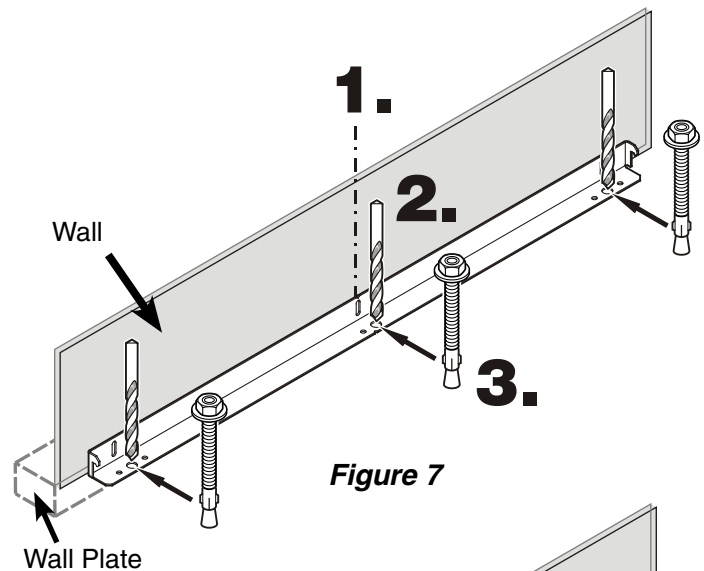


Figure 7

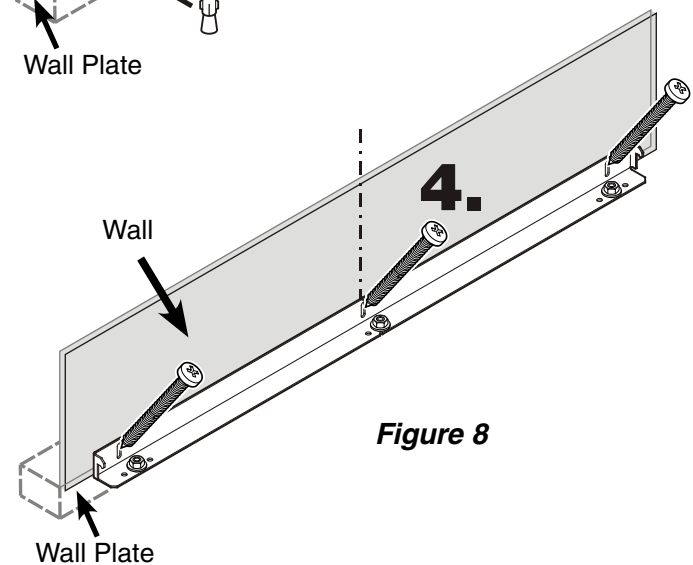


Figure 8

## Mounting the anti tipping device on wooden floors - Figure 9

1. Mark the center line of the appliance on the back wall. Align the anti tipping bracket center to this line.

### ⚠ WARNING

Be sure that there is no plumbing or electrical wiring located in this area which screws or drills could damage.

2. Fasten bracket to the wooden floor using 5 screws (1/4" x 2-1/8"). Drill pilot holes if necessary.

3. Fasten bracket with 3 screws (1/4" x 2-1/8") into the wall plate.

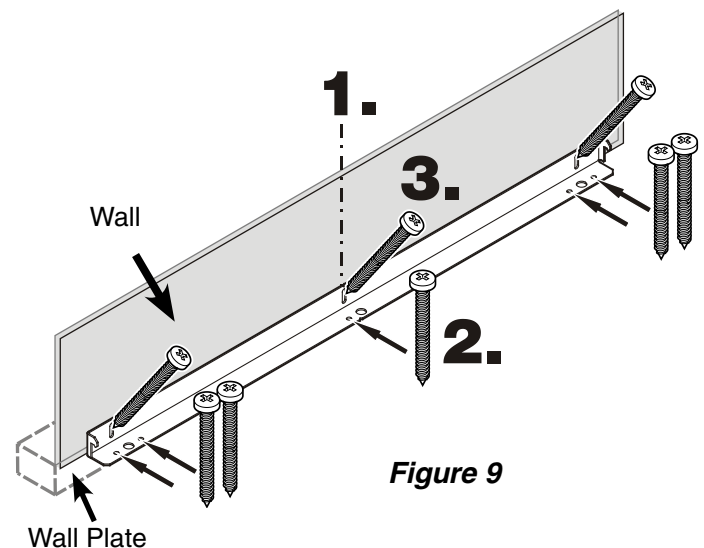


Figure 9



# BLOCKING FOR SAFETY

## Mounting the anti tipping device in cabinets deeper than 24" -

Figure 10 - 11

To ensure the compressor mounting plate reaches the anti tipping bracket in cabinets deeper than 24", a wooden spacer must be mounted between the appliance back and the wall. The anti tipping bracket will be fastened to the floor downwards and to the spacer backwards.



### WARNING

Be sure the wooden spacer is fastened securely to the floor.

### Measuring for mounting the wooden spacer on inset kitchen cabinets - Figure 10

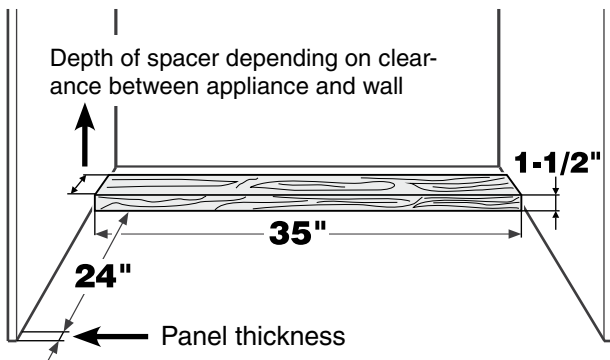


Figure 10

### Measuring for mounting the wooden spacer on frameless kitchen cabinets - Figure 11

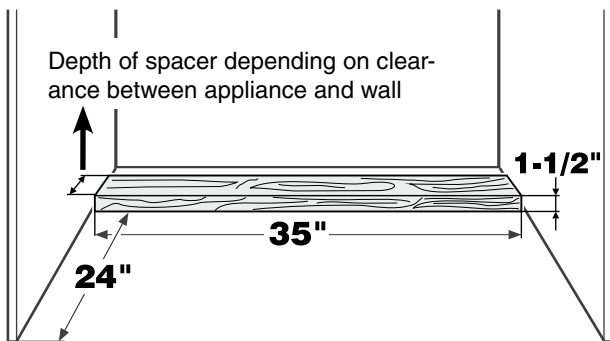


Figure 11

### IMPORTANT

If the floor slopes down sideways, the anti-tipping bracket must be fitted horizontally. Lay down spacers in the appropriate positions.

## Cover strips - Figure 12

Before connection to the water supply, the cover strips provided must be fitted to the appliance. It is necessary because the appliance will be moved into its recess.

- Remove the cover band from the strips and stick them to the left and right front edge of the appliance housing (Figure 12).

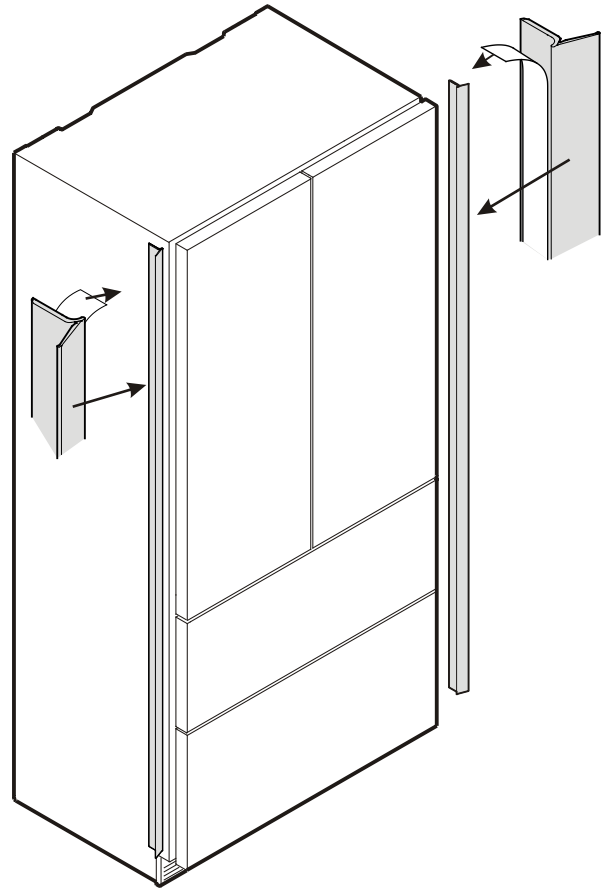


Figure 12

# ICEMAKER

## Safety Instructions and Warnings

- Do not install the water connection while the combined refrigerator-freezer is connected to an electrical outlet.
- The connection to the water supply may only be made by a trained and licensed plumber.
- All equipment and devices used to supply the water to the appliance must comply with the current regulations for your geographical area.

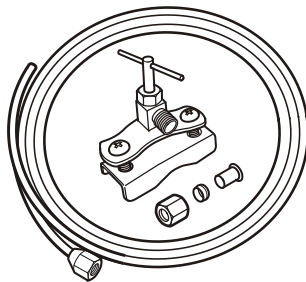


**WARNING!**

**Connect to potable water supply only.**

## Water Connection

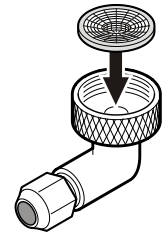
- The water supply pressure requirements are different based on whether or not the supplied Liebherr water filter is installed. With the filter installed, the pressure must be in the range of 40-90 psi (2.8-6.2 bar). Without the filter installed the acceptable pressure range is 22-87 psi (1.5-6 bar). Failure to meet these requirements will likely result in ice maker malfunction and possibly cause a water leakage that can damage flooring and surrounding furniture.
- Use a 1/4" OD copper line to connect the water supply to the solenoid valve.  
***This is not supplied with the refrigerator (Figure 13).***
- A shut-off valve, such as the saddle valve illustrated here, must be installed between the hose line and the main water supply so the water supply can be stopped if necessary.



**Figure 13**

**Do not install the shut-off valve behind the refrigeration unit.**

- The solenoid valve has a *metric R3/4* male connector. A R3/4 (metric) to a 1/4" OD adapter is supplied with the ice maker.
- Insert the water strainer provided into the OD adapter with the cavity downwards.

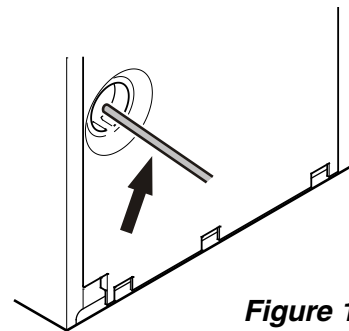


### **IMPORTANT**

*Be sure the strainer is inserted with the cavity downwards. Otherwise the strainer could be damaged when mounting the OD adapter onto the solenoid valve.*

## Connection to the Water Supply

1. Move the appliance towards the final position and leave enough space to work behind.
2. Insert the water supply line into its intended opening at the back of the appliance (**Figure 14**).



**Figure 14**

3. Move the power supply line to the area of the electrical outlet.



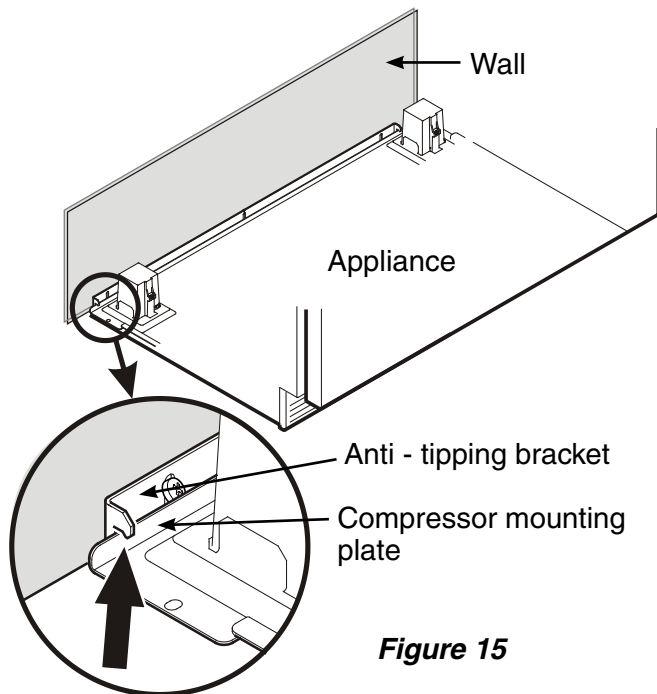
**WARNING**

**Do not connect to the electrical outlet before the installation is completed and the water line is connected to the solenoid valve.**

4. Push the appliance slowly to the back wall until the compressor mounting plate makes contact with the anti-tipping bracket (**Figure 15**).

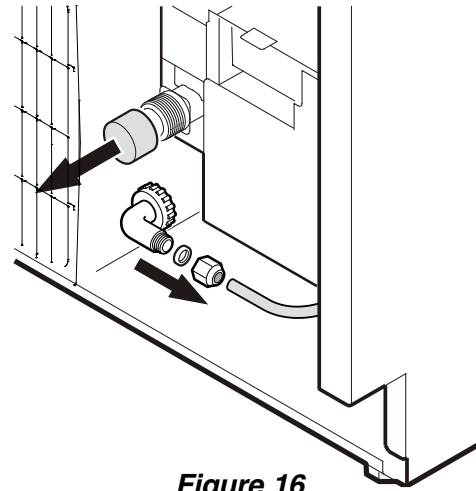
**WARNING**

To prevent the appliance from tipping forward the compressor mounting plate must have contact with the anti tipping bracket (**Figure 15**).

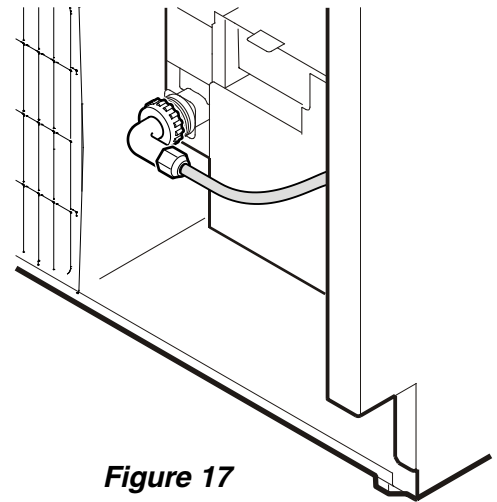


**Figure 15**

5. Remove the cover from the valve connector (**Figure 16**).
6. The water line is visible at the front of the appliance. Connect the water line with the OD adapter (**Figure 16**).
7. Bleed the air from the water line by opening the water supply temporarily.
8. Screw the OD adapter onto the solenoid valve (**Figure 17**).



**Figure 16**



**Figure 17**

9. Open the shut-off valve for the water supply and check the entire water system for leaks.

**IMPORTANT**

After starting up the appliance, the water pipe system must be purged of any air. Refer to chapter "Bleeding the ice maker" in the operating instructions.

# INSTALLATION

## Leveling the Appliance - Figure 18

1. Adjust the height of the appliance at the front by twisting the leveling feet ① (A/F 27). Use the open-ended spanner provided.
2. Adjust the height of the appliance at the rear by turning the adjusting bolts ②.
3. Rotate leveling feet ① until firmly in place against the floor.

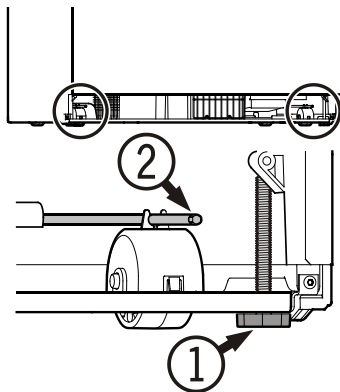


Figure 18

### ⚠ WARNING

To prevent the appliance from tipping forward the leveling feet ① (Figure 19) must have contact with the floor.

## Adjusting the front of the drawer - Figure 19

- Figure 19

If required, the front of the freezer drawers can be adjusted.

Transfer the screws shown in the illustration (on the left and right sides of the freezer drawer) individually to the long slots below.

Tighten the screws in the front of the drawer once it is in the right position.

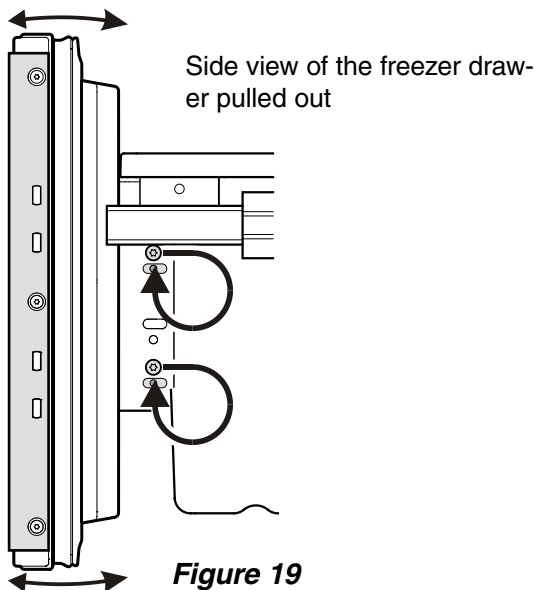


Figure 19

## Fasten the appliance in the recess - Figure 20

Fasten the appliance in the recess through the upper and lower hinges of the refrigerator doors. Use 2 screws for each hinge.

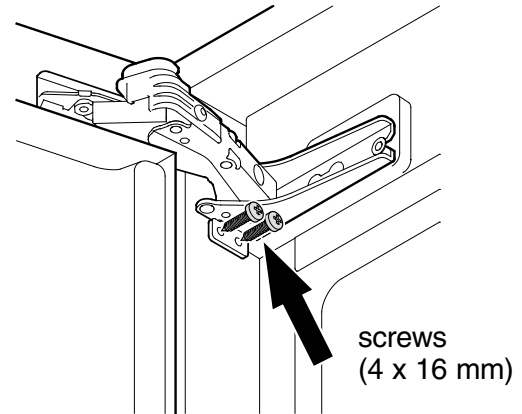


Figure 20

## Before mounting the door panels - Figure 21

- Figure 21

Remove cover ① and unscrew the upper attachment bracket ② of both refrigerator doors. These brackets will be mounted onto the refrigerator door panels.

### IMPORTANT

The nuts are needed to fit the premounted panels onto the refrigerator doors.

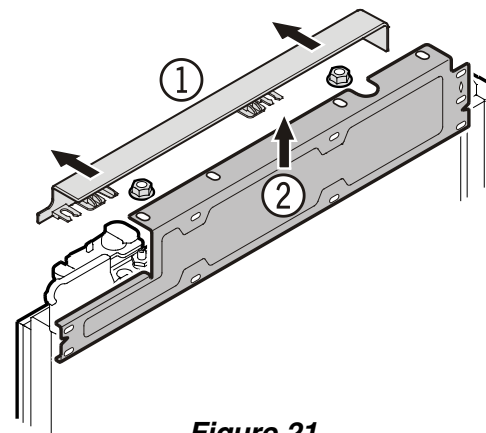


Figure 21

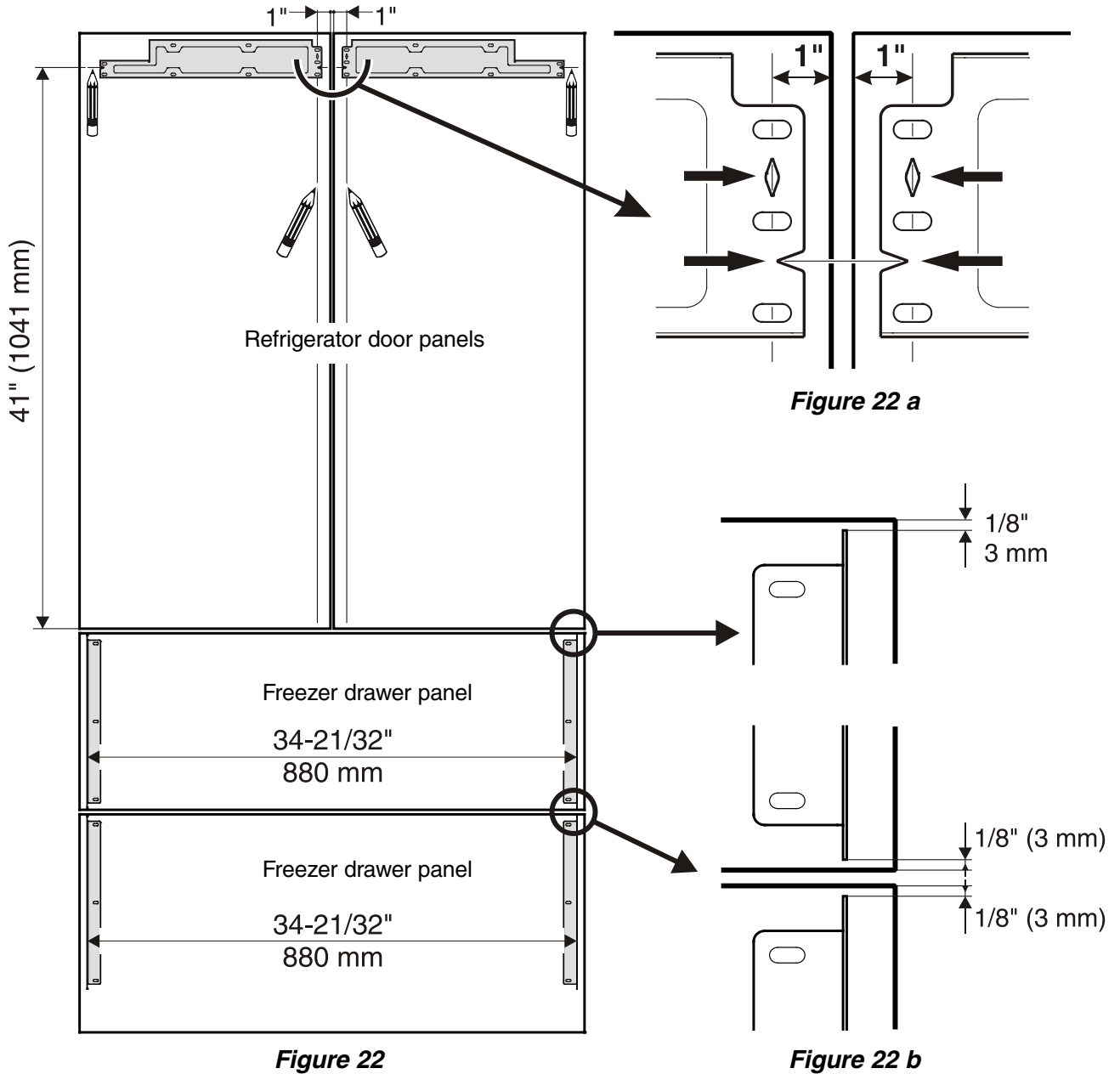
# INSTALLATION

## Mounting the attachment brackets onto the door panels - *Figure 22*

Mark lines on the refrigerator door panels as shown in *Figure 22*.

Align the dismantled brackets of the refrigerator doors to the lines on the refrigerator door panels as shown in *Figure 22 a*. Fasten each bracket with any hole wherever possible using a minimum of 6 screws 4 x 16 mm.

Fasten the brackets provided onto the freezer drawer panels using three screws (4 x 16 mm) for each bracket (*Figure 22 b*).



# INSTALLATION

## Mounting the freezer drawer panels - Figure 23

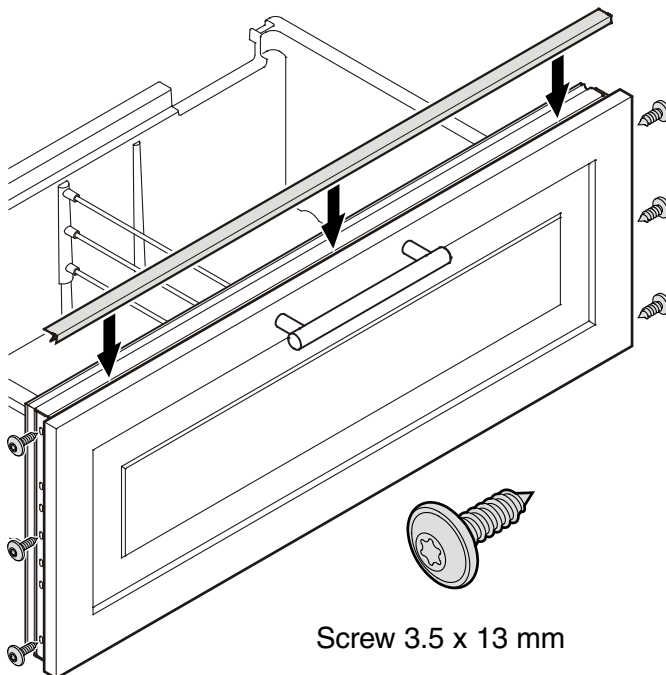
1. Pull out the upper freezer drawer and screw on the panel with three screws at left and right hand side using the screws as shown in **Figure 23**.
2. Close the drawer and check the position to the surrounding cabinet panels. Align the panel in vertical direction by loosening the screws left and right. Finally tighten the screws.



**CAUTION**

**Do not overtighten. Do not use a power driver.**

3. Pull out the lower freezer drawer and fasten the lower panel in the same way.
4. Finally cover the gap between the drawer and the panel of both freezer drawers with the strips provided. Remove the foil from the adhesive surface of the strip and stick on the top of the appliance drawer (**Figure 23**) making sure the flexible gasket is fully inserted in the gap.

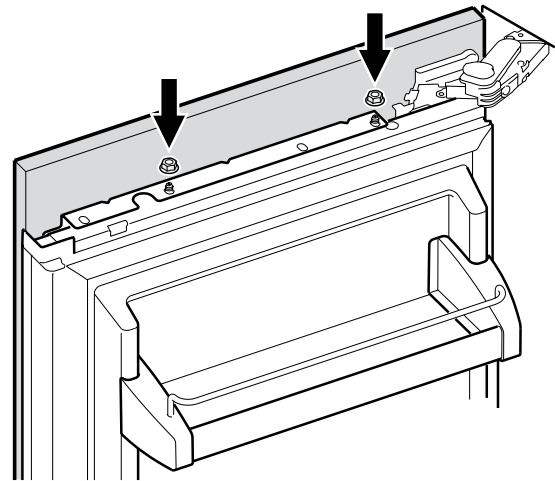


**Figure 23**

## Mounting the refrigerator door panels - Figures 24 - 33

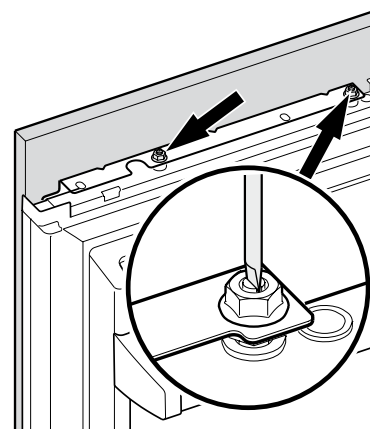
The description is for one panel only. The procedure is the same for both panels.

1. Open the refrigerator door and hang the panel on the adjusting bolts (**Figure 24**).
2. Screw on the hex nuts to the adjusting bolts and finger tighten temporarily (**Figure 24**).



**Figure 24**

3. Close the door and check the height of the panel.
4. Align the panel in its vertical position if necessary. Loosen the hex nuts and turn the adjusting bolts using a screwdriver for slotted screws (**Figure 25**).



**Figure 25**

# INSTALLATION

To make it possible to fasten the refrigerator panel at the bottom the soft-stop cylinder must be dismantled.

5. Grasp the soft-stop cylinder and pull down (**Figure 26**).

## CAUTION

The soft-stop cylinder retracts in the detached state.

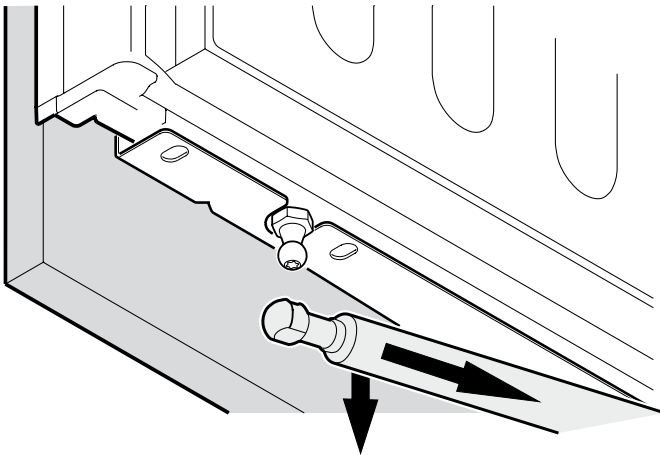


Figure 26

6. Transfer the lower edge of the attachment bracket onto the panel using a pencil. (**Figure 27**). Remove the panel from the refrigerator door.

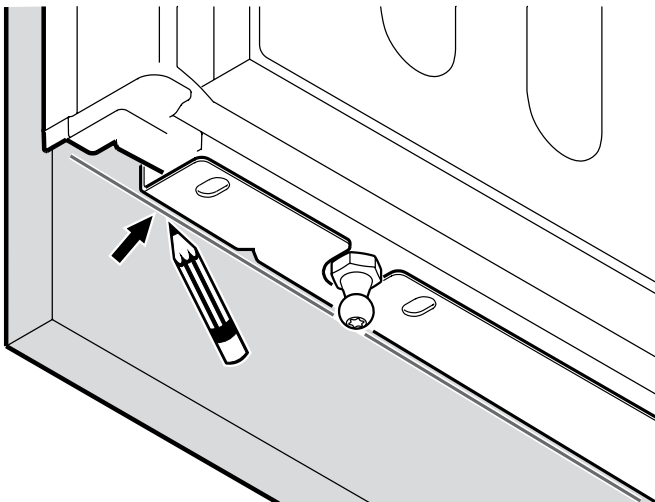


Figure 27

7. Dismantle the lower attachment bracket from the refrigerator door. Align the bracket to the lines on the refrigerator door panel. (**Figure 28**).

Fasten the bracket with any hole wherever possible using a minimum of 6 screws 4 x 16 mm.

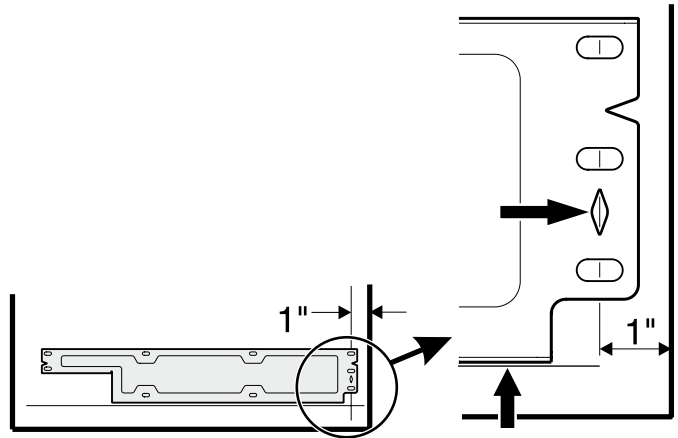


Figure 28

8. Open the refrigerator door and hang the panel on the adjusting bolts (**Figure 29**).
9. Screw on the hex nuts to the adjusting bolts and finger tighten temporarily (**Figure 29**).

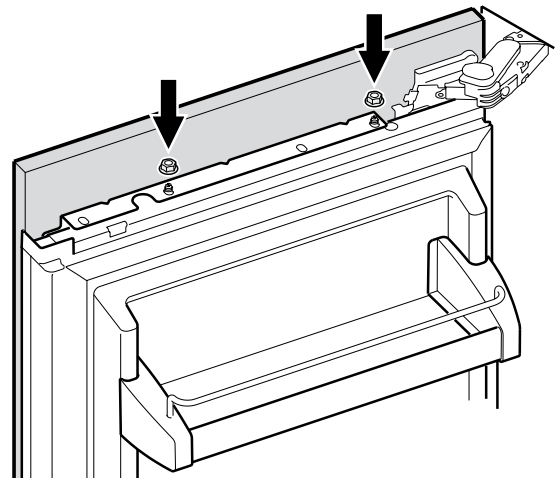
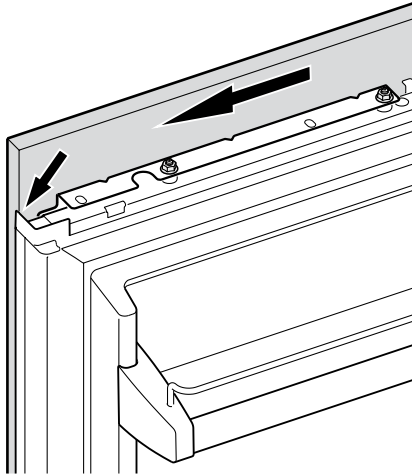


Figure 29

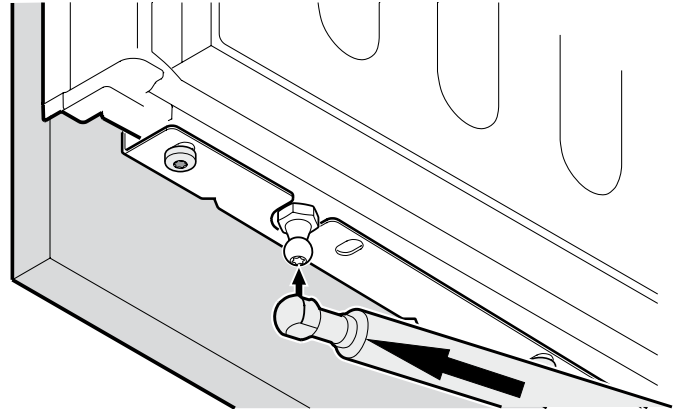
# INSTALLATION

10. Move the panel to the left until it makes contact with the center rail (**Figure 30**).
11. Tighten the hex nuts finally.



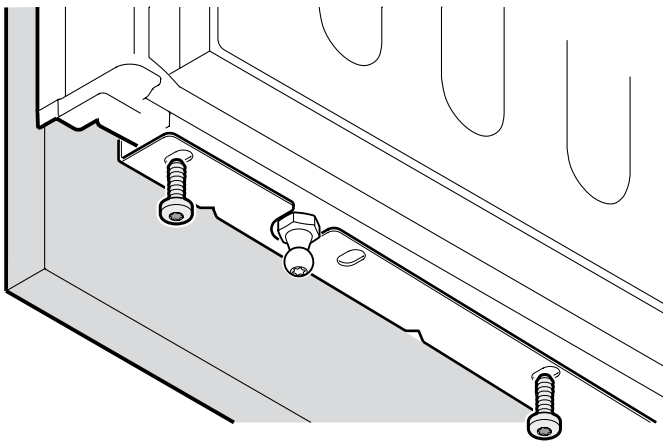
**Figure 30**

13. Extend the soft-stop cylinder and connect with the ball stud (**Figure 32**).



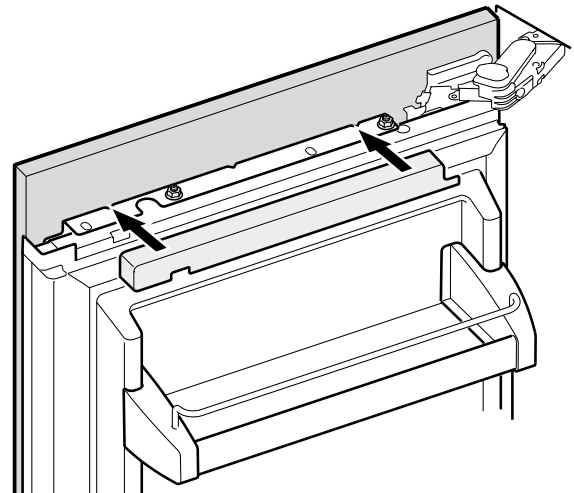
**Figure 32**

12. Fasten the refrigerator panel using the same screws that held the lower bracket before removal (**Figure 31**).



**Figure 31**

14. Click cover into place (**Figure 33**).



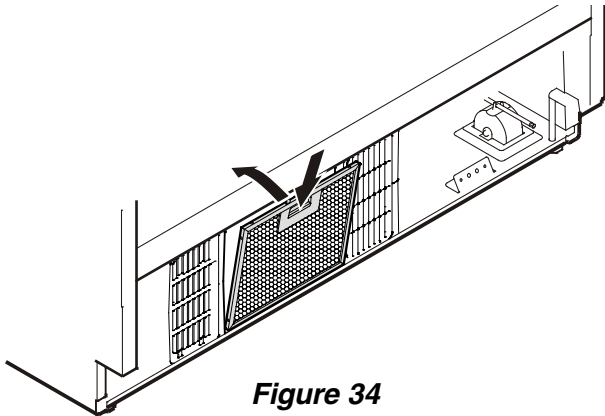
**Figure 33**



## Mounting the ventilation grille -

*Figure 34, 35*

1. Pull out the bottom freezer drawer.
2. Remove the blue protection film from the dust filter provided and insert the filter into its opening in the toe kick area as shown in **Figure 34**. Attach the filter at the bottom, press down the button and click into place.



**Figure 34**

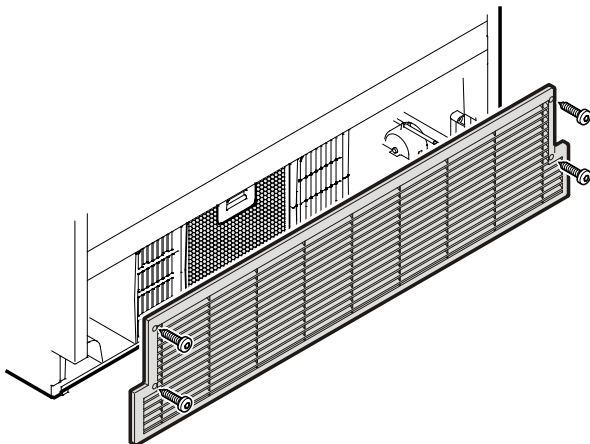
3. Mount the ventilation grille as shown in **Figure 35**.

### **IMPORTANT**

*Only use the ventilation grille provided with the appliance. This grille is required for proper operation of the appliance.*

*The ventilation opening must not be covered with a cabinet base.*

*Failure to use the supplied grille can result in product failure and will void the warranty.*



**Figure 35**