

# LIEBHERR

## Use and Care Manual

For "NoFrost" Combined  
Refrigerator-Freezers with IceMaker

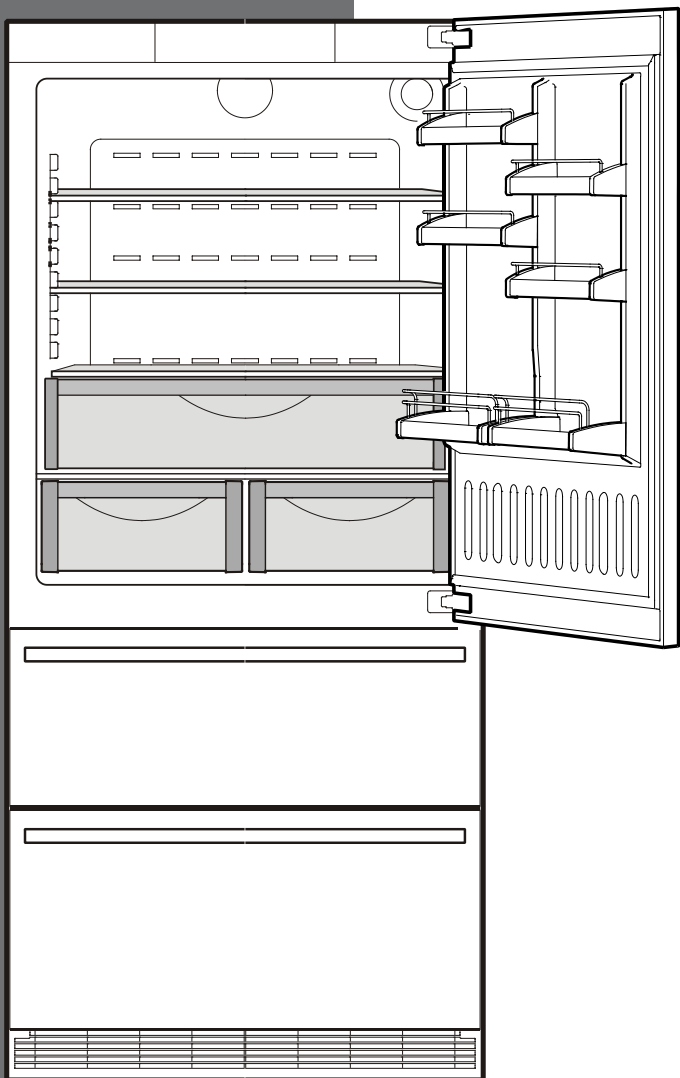

CS 2060 / HC 2060  
7084 453-00

---

---

**C**ongratulations on your purchase. Choosing this appliance means you want all the benefits of state-of-the-art refrigeration technology, guaranteeing you top quality, a long appliance life span and excellent reliability.

The features on your appliance have been designed to ensure maximum convenience - day in, day out.

This appliance has been manufactured with recyclable materials using an environmentally friendly process, so together we're making an active contribution to the preservation of our environment.

To get to know all the benefits of your new appliance, please read the information contained in these operating instructions carefully.

We know you will be pleased with your new appliance.

### **Additional benefits**

- CFC-free
- Energy-optimized refrigerant circuit
- Energy-efficient insulation
- Low energy consumption
- User-friendly electronic controls
- Display of functions switched on
- Temperature can be controlled within climate rating range, regardless of room temperature
- Refrigerator and freezer compartments defrost automatically - no need to spend time defrosting
- Big net refrigerator capacity
- Variable and practical features
- Safety-glass storage shelves
- Big net freezer capacity
- Automatic Ice Maker
- Water filter for good water quality ice production
- Freezer temperature increase alarm
- Audible door open alarm
- Power failure/"frost-control" display
- Fresh food can be fast-frozen as required
- All drawers suitable for fast freezing
- Integrated transport grips on appliance housing
- Transport castors
- Easy to clean
- This unit is certified as Sabbath compliant by the Star-K organization thus allowing the appliance to be used during religious holidays. For more information please visit Star-K on the web at [www.star-k.org](http://www.star-k.org).

# TABLE OF CONTENTS

Contents	Page
Disposal of old appliance .....	4
Electrical safety.....	4
Important safety information.....	5
Safety regulations .....	6
Disposal of carton.....	6
Water filter.....	7
Installing the Water filter .....	7
Removing the Water filter .....	7
Description of appliance and equipment .....	8
Operating and control elements .....	9
Turning the appliance on and off.....	10
Setting the temperature.....	10
Temperature display .....	11
Audible alarm signal .....	11
Power failure/Frost-control display.....	11
Supercool.....	11
Setup mode.....	12 - 15
Arranging food .....	16
Shelf arrangement.....	16
Interior light .....	17
Freezer compartment description .....	18
Removing the Freezer Compartment Containers .....	18
Freezing .....	19
Freezing with Superfrost.....	19
Freezing and Storage .....	19
IceMaker .....	20
Safety instructions and warnings.....	20
Bleeding the IceMaker.....	20
To Start the IceMaker .....	20
IceMaker at vacations.....	21
Cleaning.....	22
Cleaning the air filter.....	23
Defrosting.....	23
Vacation Tips .....	23
Troubleshooting .....	24
IceMaker Troubleshooting .....	25
Customer Service.....	25
Appliance Information.....	25
Liebherr Warranty Plan.....	26

## Please read and follow these instructions

These instructions contain Danger, Warning and Caution statements.

This information is important for safe and efficient installation and operation.

Always read and follow all Danger, Warning and Caution statements!



### DANGER!

**Danger indicates a hazard which will cause serious injury or death if precautions are not followed.**



### WARNING!

**Warning indicates a potentially hazardous situation which, if not avoided, could result in death or serious injury.**



### CAUTION!

**Caution indicates a potentially hazardous situation which, if not avoided, may result in minor or moderate injury.**

### IMPORTANT

*This highlights information that is especially relevant to a problem-free installation and operation.*

### IMPORTANT

*All types and models are subject to continuous improvement. The manufacturer reserves the right to make modifications in the shape, equipment and technology.*

# SAFETY

## Disposal of old appliance



**DANGER!**

### Risk of child entrapment.

Child entrapment and suffocation are not problems of the past.

Junked or abandoned refrigerators are still dangerous – even if they will sit for “just a few days.”

If you are getting rid of your old refrigerator, please follow these instructions to help prevent accidents.

### Before you discard old appliances:

- Remove the doors.
- Leave the shelves in place so that children may not easily climb inside.
- Cut off the power cable from the discarded appliance. Discard separately from the appliance.
- Be sure to follow your local requirements for disposal of appliances.

Contact the trash collection agency in your area for additional information.

## Disposal of this appliance

This appliance contains flammable gases within the refrigeration circuit and insulation foam.

Contact the Municipality or Disposal Company in your area for information on approved recycling or disposal.

## Disposal of carton

The packaging is designed to protect the appliance and individual components during moving and is made of recyclable materials.



**WARNING!**

**Keep packaging materials away from children. Polythene sheets and bags can cause suffocation!**

Please recycle packaging material where facilities are available.

## R600a refrigerant



**WARNING!**

The refrigerant contained within the appliance R600a is environmentally friendly, but flammable. Leaking refrigerant can ignite.

To prevent possible ignition follow the warnings below:

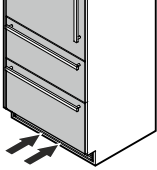
- Keep ventilation openings, in the appliance enclosure or in the built-in structure, clear of obstruction. 
- Do not use mechanical devices or other means to accelerate the defrosting process, other than those recommended by the manufacturer.
- Do not damage the refrigerant circuit.
- Any repairs and work on the appliance should only be performed by the customer service department.
- Do not use electrical appliances inside the food storage compartments of the appliance, unless they are of the type recommended by the manufacturer.

## Setting up

Avoid placing the appliance in direct sunlight or near the stove, range top, radiators and similar heat sources.

As soon as you uncrate the unit:

- Examine the unit and packaging for shipping damage. Contact the carrier immediately if you suspect there is any damage.
- Note the type (model number), index, appliance / serial number, date of purchase and where purchased on the spaces provided in the back of this manual.

## Important safety information

- To prevent injury to you or damage to the unit, the appliance should be unpacked and set up by two people.
- If the appliance is damaged on delivery, contact the supplier immediately before connecting to the power source.
- To guarantee safe operation, ensure that the appliance is set up and connected as described in these operating instructions.
- Disconnect the appliance from the power source if a fault occurs. Pull out the plug, turn off or remove the fuse.
- When disconnecting the appliance, use the plug. Do not pull on the cable.
- Any repairs and work on the appliance should only be carried out by the customer service department. Unauthorized work may be dangerous to the user. Changing the power source cable should only be done by the customer service department.
- Do not eat ice cream, particularly ice cream treats, or ice cubes, immediately from the freezer compartment. There is a risk of “burning” because of the very cold temperatures.
- Do not consume food which has been stored for too long; it could cause food poisoning.
- Do not store explosives or sprays using combustible propellants such as butane, propane, pentane, etc. in the appliance. Electrical components might cause leaking gas to ignite. You may identify such sprays by the printed contents or a flame symbol.
- Do not allow children to play with the appliance. Children must not climb, sit or stand on the shelves, drawers or door.
- To prevent possible injury due to an electrical shock, be sure to disconnect the power cord or turn off the circuit breaker before cleaning the appliance.
- To avoid injury or damage to the appliance, do not use steam cleaning equipment to clean the appliance.
- Do not operate the refrigerator in the presence of explosive fumes.
- In the event of a power outage, minimize opening the refrigerator door(s). Protect the food either by placing dry ice on top of the packages or using a local frozen food locker if the power failure is of a long duration. Do not attempt to re-freeze any previously frozen food that has thawed.

# SAFETY

## Electrical safety

Connect this appliance to a 15 amp or 20 amp, 110-120 VAC, circuit which is grounded and protected by a circuit breaker or fuse.

We recommend using a dedicated circuit for this appliance to prevent circuit overload and the chance of interruption to the appliance.

This appliance is equipped with a three-prong (grounding) polarized plug for your protection against possible shock hazards.

Where a two-prong wall receptacle is encountered, contact a qualified electrician and have it replaced with a properly grounded three-prong receptacle in accordance with all local codes and ordinances.



### WARNING!

**Electrocution hazard.**

**Electrical grounding required.**

- Do not remove the round grounding prong from the plug. →
- Do not use extension cords or ungrounded (two prong) adapters.
- Do not use a power cord that is frayed or damaged.

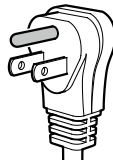

- Do not use a power strip. →

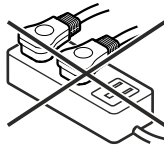

**Failure to follow these instructions may result in fire, electrical shock or death.**

## Safety regulations

The appliance is designed to cool, freeze and store food and to make ice. It is designed as a household appliance.

### IMPORTANT

***The appliance is not intended for outdoor use.***

The appliance is manufactured to operate within specific ambient temperature limits according to its climate rating.

The climate rating indicates the ambient temperature at which the appliance may be operated in order to achieve full refrigeration performance.

#### Climate Rating

SN-T

#### Ambient Temperature

50°F to 109°F (10°C to 43°C)

### IMPORTANT

***Do not operate the appliance outside the specified ambient temperature range.***

- The refrigerant circuit has been tested for leaks.
- The appliance complies with current safety regulations UL250 and CSA C22.2 #63.

We recommend cleaning the appliance before turning it on for the first time. See **Cleaning**.

Turn on the appliance several hours before loading it.

Do not load with frozen food until the temperature shows approximately 0°F (-18°C).



### WARNING!

**Do not allow children to play with the appliance. Children must not climb, sit or stand on the racks or door.**

**Failure to follow these instructions may result in death or serious injury.**

# WATER FILTER

## Water Filter - Figure 1

Before turning on the appliance install the water filter provided in the interior rear wall of the refrigerator compartment. This ensures good ice cube quality and keeps the water circuit free of solids such as sand.

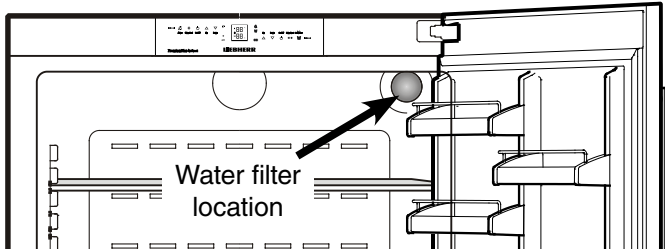
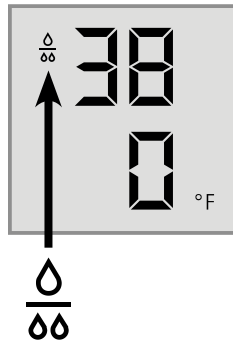

Figure 1

Replace the filter when the drop symbol appears on the temperature display. Filters can be obtained from your Liebherr Dealer or Distributor.



## WARNING

To avoid the risk of bacteria growth, the water filter must be changed when the waterdrop symbol appears on the display!

### IMPORTANT NOTE

It is not necessary to turn off the water supply when removing or installing the water filter.

## Installing the Water Filter - Figure 2 and Figure 3

1. Remove cover of the filter socket.

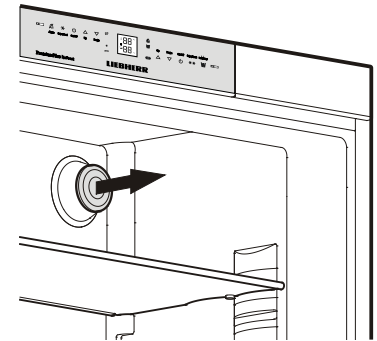

Figure 2

2. Insert the filter and turn it 90° clockwise.

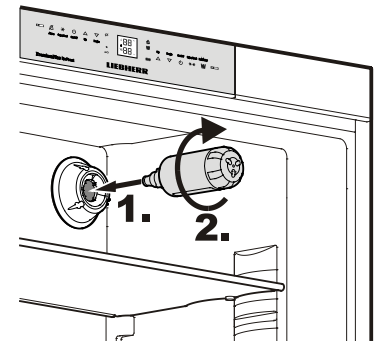

Figure 3

## Removing the Water Filter - Figure 4

3. Turn the filter 90° counterclockwise and remove.

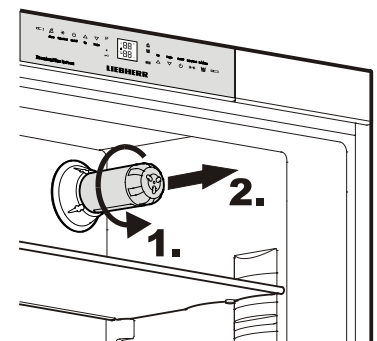
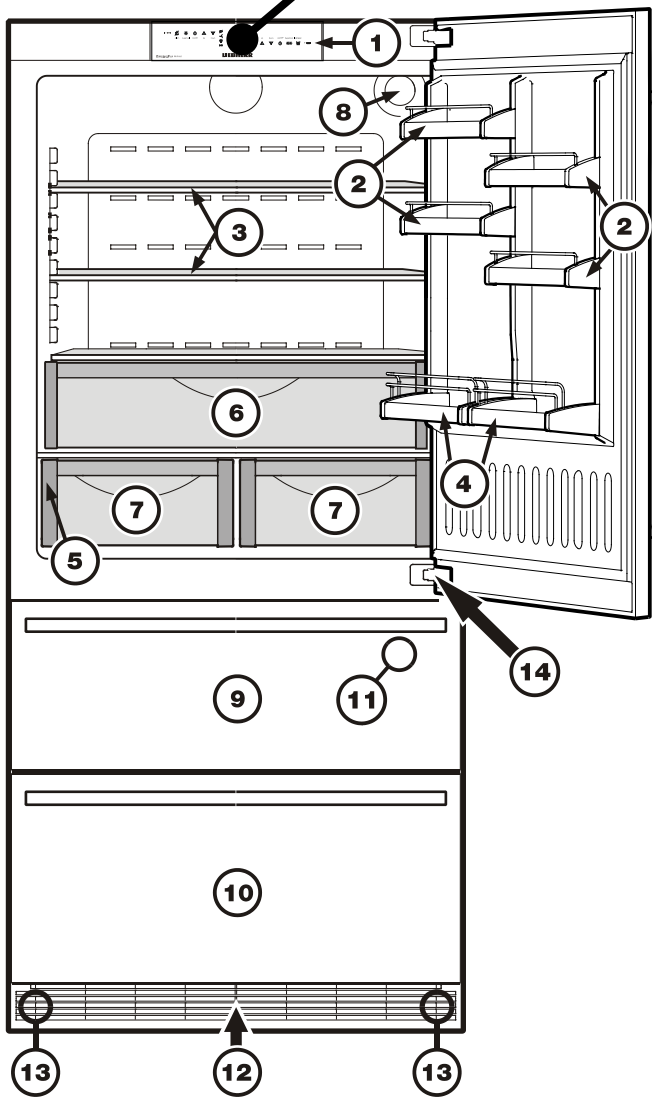
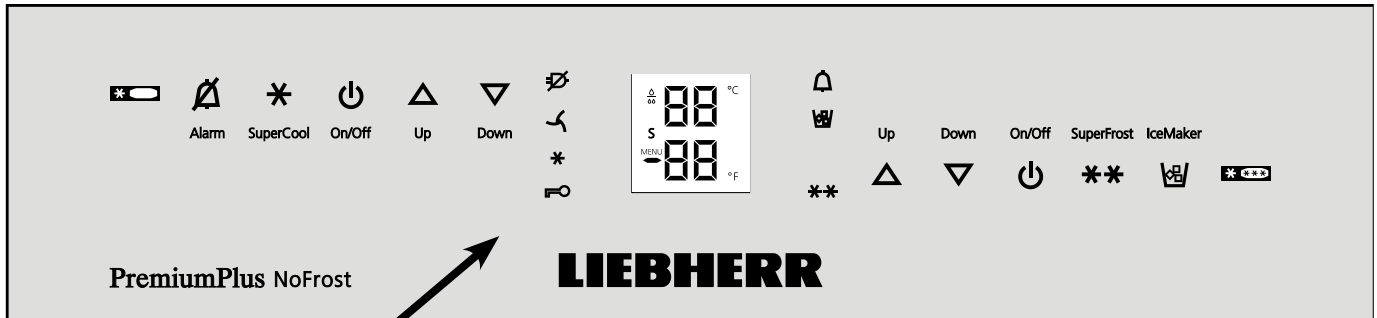

Figure 4

# FEATURES

## Description of appliance and equipment - Figure 5



### Description of Refrigerator

- (1) Operating and Control Elements
- (2) Adjustable Door Racks
- (3) Adjustable Shelves
- (4) Gallon Rack
- (5) Model Plate (behind the Vegetable Bin on the left hand side)
- (6) Drawer
- (7) Vegetable Drawers
- (8) Water Filter

### Description of Freezer

- (9) Upper Freezer Drawer
- (10) Lower Freezer Drawer
- (11) Ice Maker (in the interior of the Upper Freezer Drawer)
- (12) Ventilation Grille
- (13) Adjustable-Height Unit (behind the Ventilation Grille)
- (14) Lower hinge

Figure 5



## Operating and Control Elements - Figure 6, Figure 7

The electronic control panel has the new **“Touch capacitance technology”**. Any function can be activated by a fingertip on the symbol of the operating icons.

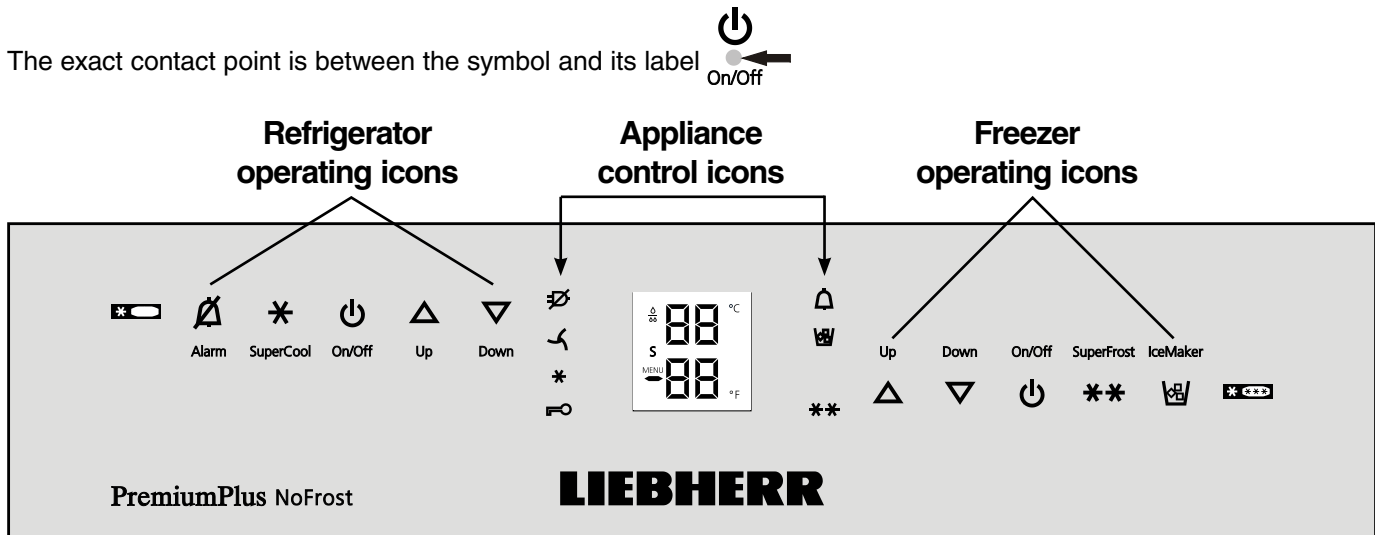

Figure 6

### Refrigerator operating icons

- Alarm mute (refrigerator and freezer)
- Supercool
- Refrigerator On/Off
- Temperature Up control (to increase the refrigerator temperature)
- Temperature Down control (to reduce the refrigerator temperature)

### Appliance control icons

- Power Failure LED
- Air Filter LED  
When this LED lights up the air filter in the toe kick area has to be cleaned.
- Supercooling LED
- Child Lock LED
- Alarm LED
- IceMaker on LED
- Superfrost LED

### Freezer operating icons

- Temperature Up control (to increase the freezer temperature)
- Temperature Down control (to reduce the freezer temperature)
- Freezer On/Off
- Superfrost
- IceMaker On/Off

## Temperature and control display

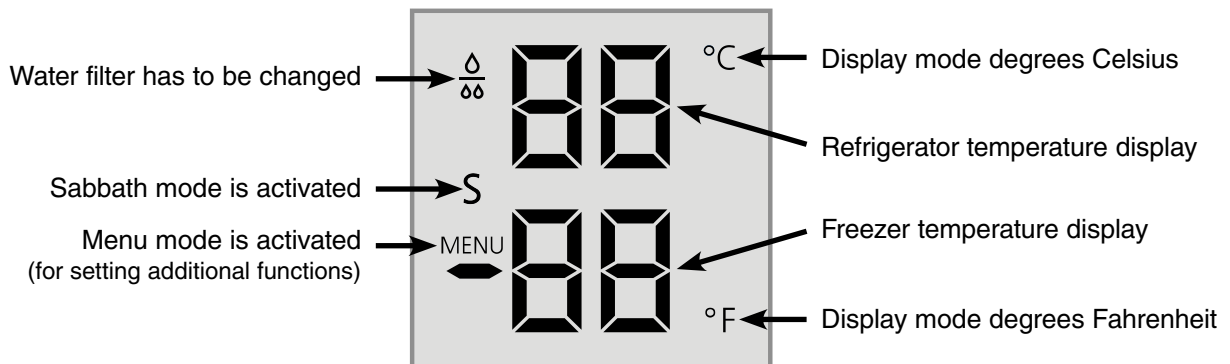

Figure 7

# OPERATION

## Turning the Appliance on and off - Figure 8

Clean the appliance before turning it on for the first time. See **Cleaning**.

Do not place frozen food in the freezer until the temperature shows at least 0°F / -18°C. The refrigerator and freezer compartments can be operated separately.

### 1. Turning on:

Touch the Refrigerator On/Off icon

and the Freezer On/Off icon

so the Temperature Displays light up.

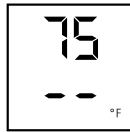

The interior light will turn on if one of the refrigerator doors or freezer drawers are open.

**2. Turning off:** To turn off the refrigerator or freezer, touch the corresponding On/off icon for approximately 3 seconds so the temperature display and interior lights go out.

## Setting the Temperature - Figure 8

The appliance is pre-set for normal operation. We recommend temperatures of 38°F (3°C) in the refrigerator and 0°F (-18°C) in the freezer.

### To reduce the temperature:

Touch the DOWN icon on the left to reduce the refrigerator temperature and the DOWN icon on the right to reduce the freezer temperature.

### To increase the temperature:

Touch the UP icon on the left to increase the refrigerator temperature and on the right to increase the freezer temperature.

1. While you are entering the temperature, **the set temperature will flash** on the display.
2. When you touch the temperature setting icons for the first time, the most recent setting is displayed.
3. You can change the settings in increments of 1°F (1°C) by briefly touching the icons again. If the icons are held the temperature setting will change faster.
4. Approximately five seconds after the icon has been released, the display will automatically show the actual freezing or cooling temperature.
5. You can change the temperatures:
  - **In the refrigerator** – between 36°F and 44°F (2°C and 6°C) and
  - **In the freezer** – between -15°F and 7°F (-27°C and -14°C).

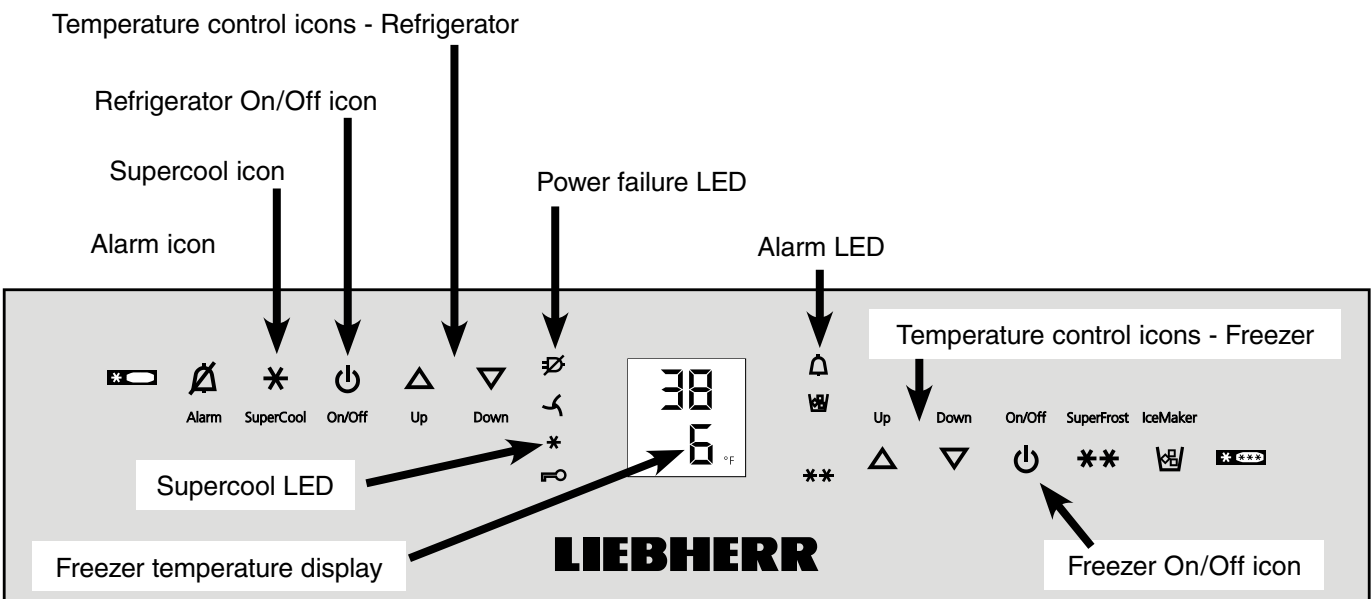

Figure 8

## Temperature Display - Figure 8

In normal operation, the following settings will be displayed:

- the average refrigerator temperature
- the warmest frozen food temperature.

When starting up for the first time or when the appliance is warm, dashes will appear in the freezer temperature display, until the temperature in the freezer compartment is 32°F (0°C).

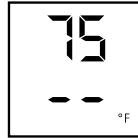

It will take between three and eight hours for the required temperature, 0°F or 38°F (-18°C or 3°C) to be reached and displayed permanently in the display, depending on the ambient conditions and the temperature setting.

### The display will flash:

- if you change the temperature or
- if the temperature rises by several degrees, indicating cold loss, e.g. if you place fresh, “warm” food in the freezer or if you remove or repack frozen food, the temperature may rise for a short time due to warm air flowing into the freezer.
- If “F1” to “F5” appears in the display, the appliance has a fault. Have the fault number available when you contact the customer service department.

## Power Failure/Frost-Control Display - Figure 8

If the power failure LED  is lit, this means the freezer temperature has risen too **high** during the last few hours or days due to a power failure. The freezer temperature display flashes at the same time.

- If you touch the **Alarm** icon now, the highest temperature registered during the power failure will be displayed.
- Check the quality of the food in case it has become too warm or even defrosted.
- The highest temperature will appear for approximately one minute. After that, the actual temperature in the freezer will reappear.

The display can be turned off by touching the Alarm icon again.

## Audible alarm signal - Figure 8

The audible alarm signal helps to protect frozen food and to save energy.

**The audible alarm signal is switched off** by touching the alarm icon.

### Audible door alarm

This sounds when the door has been left open for longer than about 180 seconds. The sound switch-off function is active as long as the door is left open. The alarm automatically switches back to standby when the door is shut.

### Audible/visual temperature alarm

It always sounds if the freezer temperature is not low enough. The *temperature display and the alarm LED  flashes* at the same time.

This can be caused by:

- warm, fresh food being placed in the freezer;
- too much warm air from the outside entering when re-arranging or removing frozen food,
- a fault in the appliance.

The temperature display will continue to *flash* until the cause of the alarm has been rectified. It will then stop flashing and light up continually. The audible warning signal is now automatically *reset*.

## Supercool - Figure 8

Touching the Supercool icon switches the refrigerator compartment to maximum cooling. It is recommended particularly if you wish to cool large quantities of food, drinks, freshly baked goods or meals rapidly.

- **Turning on:** Touch the Supercool icon briefly so the LED  turns on. The refrigerator temperature will drop to its lowest value.

### IMPORTANT

*The Supercool function uses slightly more energy. After approximately six hours, however, the refrigerator switches back automatically to normal energy-saving operation. If required, the Supercooling function can be turned off sooner.*

- **Turning off:** Touch the Supercool icon again until the LED  turns off.

# OPERATION

## Setup Mode

In the setup mode you can activate the following functions:

⏏ = Sabbath mode

🔒 = Child proof lock

↺ = Drop symbol reset

⏸ = Icemaker vacation state

📏 = Water quantity for Ice cube tray

🌡 = Temperature display mode

📺 = Display brightness

🔥 = Lower hinge heating control

🔄 = Reset Air filter LED

### How to activate the setup mode - Figure 9

- Touch the **Superfrost** icon for approximately five seconds
  - the **Superfrost LED \*\*** turns on for 5 seconds
  - after 5 seconds ⏏ will flash in the display.

The appliance is in the setup mode now.

You can select the setup mode functions by touching the freezer compartment **Up/Down** icons.

#### Note

*In the setup mode the display will flash continuously.*

### Exit setup mode:

- Touch the freezer compartment **On/Off** icon. The appliance will change back to normal operation.



## ⏏ = Sabbath mode

This feature considers the Religious requirements on Sabbath or Holidays. When the Sabbath mode is active some functions of the electronic controls are switched off.

### The door can be opened and closed at any time.



- The lighting remains off.
- The cooling fan remains in its actual state: If it is on it remains on, if it is off it remains off.
- There is no door alarm.
- There is no temperature alarm.
- Defrost cycles are independent of the number of times and length of door openings.
- The unit will return into Sabbath Mode after a power failure.

### How to activate the Sabbath mode

- Activate the setup mode by touching the **SuperFrost** icon for 5 seconds.
  - the display shows ⏏
- Touch the **SuperFrost** icon
  - the display shows 
- Touch the **SuperFrost** icon again
  - the display shows 
  - the Sabbath mode is activated.
- Exit setup mode by touching the freezer compartment **On/Off** icon.

Sabbath mode switches off automatically after 120 hours if it is not manually switched off beforehand.



### How to deactivate the Sabbath mode

- Activate the setup mode by touching the **SuperFrost** icon for 5 seconds.
  - the display shows ⏏
- Touch the **SuperFrost** icon
  - the display shows 
- Touch the **SuperFrost** icon again
  - the ⏏ symbol  in the display disappears,
  - the Sabbath mode is deactivated.
- Exit setup mode by touching the freezer compartment **On/Off** icon.



## ☐ = Child lock

The child lock is designed to protect the appliance from being turned off accidentally.

### How to activate the child lock

- Activate the setup mode by touching the **Superfrost** icon for 5 seconds
- Touch the **freezer compartment Down** icon until ☐ appears in the freezer temperature display.
- Touch the **Superfrost** icon
  - the display shows 
- Touch the **Superfrost** icon again
  - the LED  is lit and the child lock is activated.
- Exit setup mode by touching the freezer compartment **On/Off** icon.

### How to deactivate the child lock



- Activate the setup mode by touching the **Superfrost** icon for 5 seconds.
  - the display shows 
- Touch the **Superfrost** icon
  - the display shows 
- Touch the **Superfrost** icon again
  - the LED  goes out. The child lock is deactivated.
- Exit setup mode by touching the freezer compartment **On/Off** icon.

## F = Drop symbol reset

After the Water filter has been changed the drop symbol on the display must be reset.



### How to reset the drop symbol

- Activate the setup mode by touching the **Superfrost** icon for 5 seconds.
- Touch the **freezer compartment Down** icon until F appears in the freezer temperature display.
- Touch the **Superfrost** icon
  - the display shows 
- Touch the **Superfrost** icon again
  - the display shows 
- The drop symbol disappears.
- Exit setup mode by touching the freezer compartment **On/Off** icon.

## { = Ice maker vacation state

Refer to chapter "Ice Maker" for explanation.

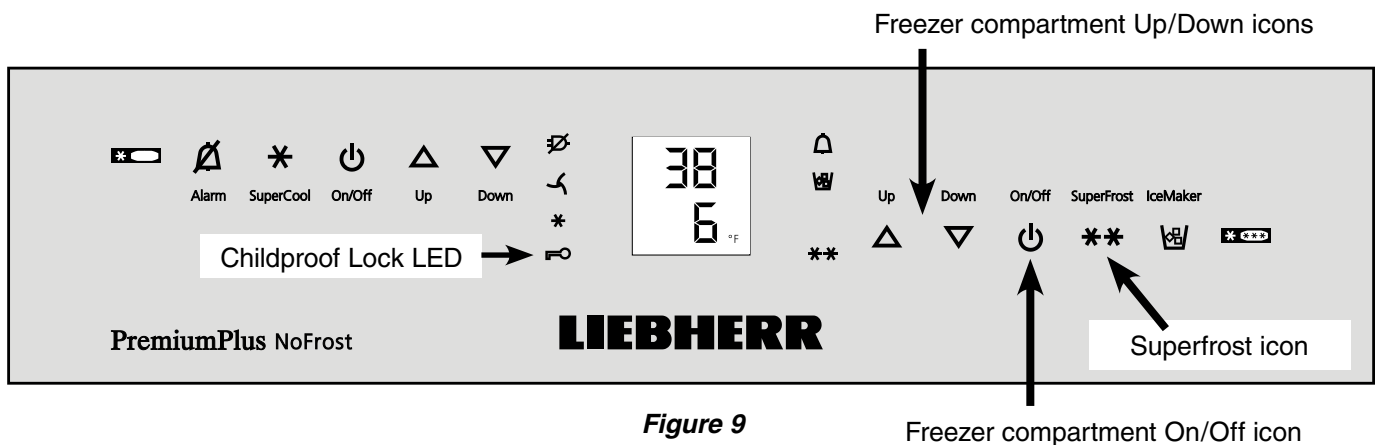

Figure 9

# OPERATION

## Setup Mode - Figure 10

### E = Water quantity for Ice cube tray

If the produced ice cubes of the Ice Maker are too small, the inflowing water quantity can be adjusted.

### How to adjust the water quantity

- Activate the setup mode by touching the **Superfrost** icon for 5 seconds.
- Touch the **freezer compartment Down** icon until E appears in the freezer temperature display.
- Touch the **Superfrost** icon
  - the display shows 
- Touch **freezer compartment Up** icon once only so E4 appears in the display.

### CAUTION

**Do not increase for more than one step. If the adjusted value is too high the ice cube tray of the Ice Maker could overflow.**

- Touch the **Superfrost** icon again.
- Exit setup mode by touching the freezer compartment **On/Off** icon.

Check the ice cube size within the next days. If the ice cubes are still smaller as desired, follow the steps above again.

### □ = Temperature display mode

You can choose the **unit of temperature** for the display in degrees Fahrenheit or degrees Celsius.

#### Note

*The factory setting is degrees Fahrenheit.*

### How to change the temperature display to degrees Celsius

- Activate the setup mode by touching the **Superfrost** icon for 5 seconds.
- Touch the **freezer compartment Down** icon until □ appears in the freezer temperature display.
- Touch the **Superfrost** icon
  - the display shows 
- Touch the **Superfrost** icon again
  - the temperature reading is now displayed in degree Celsius.
- Exit setup mode by touching the freezer compartment **On/Off** icon.

#### Note

*To change the temperature display back to degrees Fahrenheit, follow the steps above.*

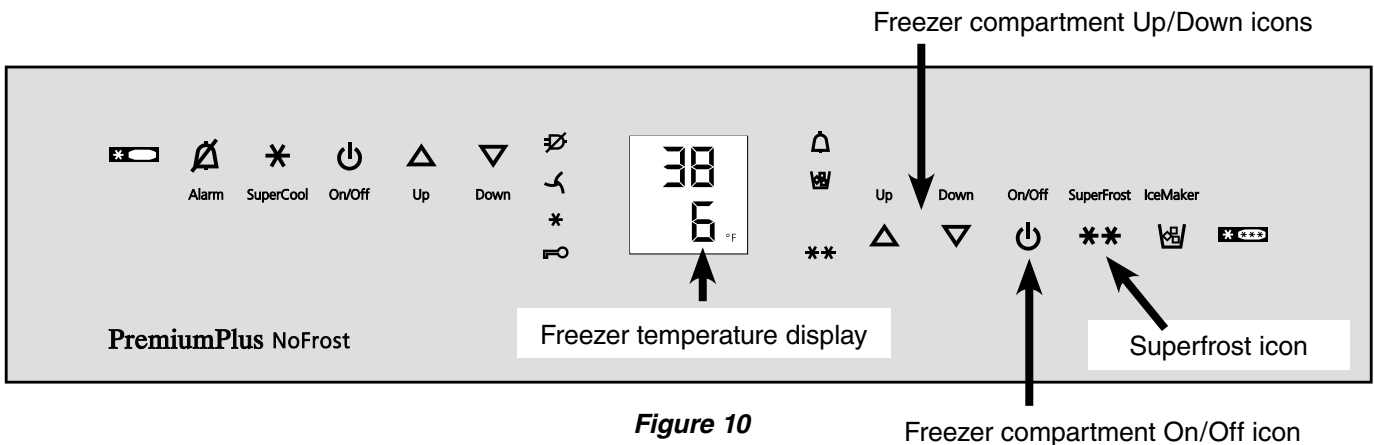

Figure 10

## h = Display brightness

### How to adjust the display brightness

- Activate the setup mode by touching the **Superfrost** icon for 5 seconds.
- Touch the **freezer compartment Down** icon until **h** appears in the freezer temperature display.
- Touch the **Superfrost** icon

- the display shows

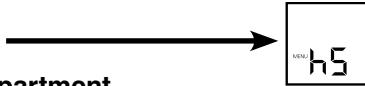

- Touch **freezer compartment Up/Down** icons to select  
**h 0** = minimum to  
**h 5** = maximum brightness

- Touch the **Superfrost** icon at the desired value.
- Exit setup mode by touching the freezer compartment **On/Off** icon.

## H = Lower hinge heating control

If condensed water appears in the lower hinge area or on the base plate between refrigerator and freezer compartment increase the output of the heating located behind the base plate.

The factory setting is set to **HA** = medium output

### How to change the heating output

- Activate the setup mode by touching the **Superfrost** icon for 5 seconds
- Touch the **freezer compartment Down** icon until **H** appears in the freezer temperature display.
- Touch the **Superfrost** icon

- the display shows

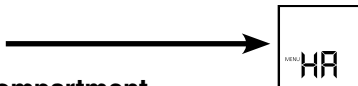

- Touch **freezer compartment Up/Down** icons to select

**HA** = at slight condensation  
**H 1** = at heavy condensation  
**H 0** = heating off

- Touch the **Superfrost** icon at the desired value.
- Exit setup mode by touching the freezer compartment **On/Off** icon.

#### Note

*With normal ambient conditions no condensation will appear. With high humidity and low ambient temperature this feature helps to prevent condensation.*

## n = Reset air filter LED

After the air filter in the toe kick area has been cleaned the air filter LED must be reset. For how to clean the air filter refer to chapter "Cleaning".

### How to reset the air filter LED

- Activate the setup mode by touching the **Superfrost** icon for 5 seconds.
- Touch the **freezer compartment Down** icon until **n** appears in the freezer temperature display.

- Touch the **Superfrost** icon

- the display shows

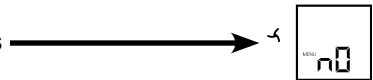

- Touch the **Superfrost** icon again

- the display shows

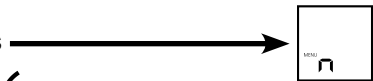

- The air filter LED  disappears.
- Exit setup mode by touching the freezer compartment **On/Off** icon.

# REFRIGERATOR COMPARTMENT

## Arranging Food - Figure 11

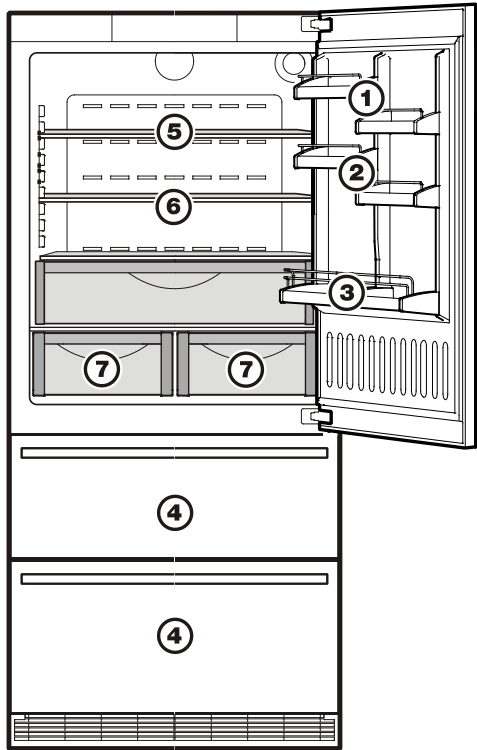

Figure 11

- (1) Butter, cheese
- (2) Eggs, cans, drinks, bottles
- (3) Gallon containers
- (4) Frozen food, ice cubes
- (5) Meat and sausage products, dairy products
- (6) Baked goods, pre-cooked meals
- (7) Fruit, vegetables, salad

### IMPORTANT

- Liquids and food which give off or absorb odors and flavors should always be stored covered or in closed containers.
- High-percentage alcohols should be tightly sealed and stored upright.
- Fruit, vegetables and salad can be stored unpacked in the bins.

## Shelf Arrangement

### To remove the vegetable drawer

Pull the drawer straight out, grip at the back and lift out - Figure 12.

### To install the vegetable drawer

Place the drawer on the rails. The rails must be fully extended and aligned with the front of the drawer. Slide the drawer in.

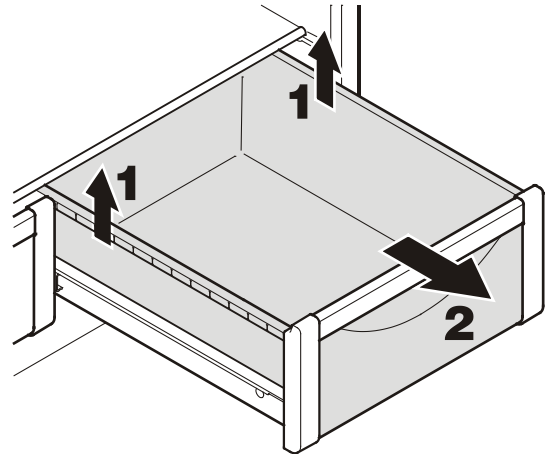

Figure 12



# REFRIGERATOR COMPARTMENT

## Repositioning the shelves - *Figure 13*

1. Hold the shelf underneath with your hand to avoid from tipping down backwards when removing.
2. Lift the shelf at the front.
3. Remove the shelf forward until the circular cutout of the shelf is in line with the interior light cover.
4. Lift the shelf up or down and replace in the desired position.

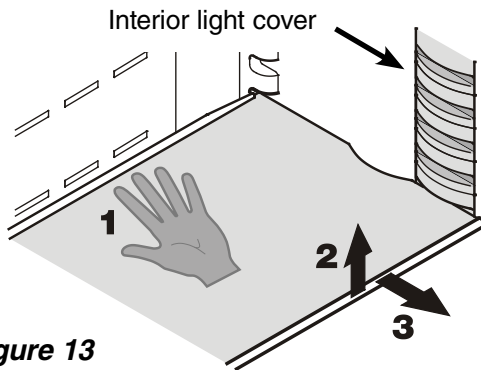

**Figure 13**

## Removing the shelves - *Figure 14*

1. Follow the first three steps in the chapter above.
2. Lift the shelf down and stop just over the upper vegetable bin.
3. Move the front of the shelf upwards until the shelf is in a vertical position.
4. Turn the shelf out at left and remove.

### ⚠ WARNING

To avoid it falling down, always hold the shelf with both hands when removing.

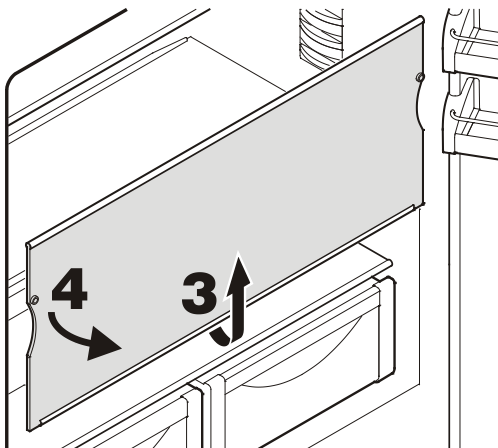

**Figure 14**

## Interior Light

The interior light is located at the left, right and top in the refrigerator compartment (**Figure 15**) and above each drawer in the freezer compartment. It turns on if one of the doors or one freezer drawer is opened.

### ⚠ WARNING

The interior light emits class 1M laser radiation. Do not look directly at light or through any optical instruments when the light cover is removed. Severe eye injury can occur.

The light turns off automatically if one of the doors or one freezer drawer has been opened for approximately 15 minutes. The audible alarm sounds at the same time.

If one light is not lit, it is defective.

### ⚠ WARNING

The interior light may only be replaced by the customer service technician or by competent skilled personnel!

Do not try to change the defective lighting yourself!

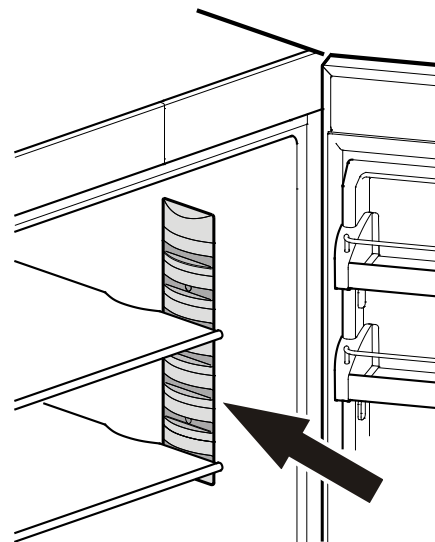

**Figure 15**

# FREEZER COMPARTMENT

## Freezer Compartment

### Description - Figure 16

Both drawers can be used for freezing food or storing frozen food.

The Ice cube bin in the upper drawer is intended for ice cubes only.

If you need the whole upper drawer for freezing or storage, the ice cube bin can be removed.

### **IMPORTANT**

*The ice maker will not eject the ice cubes of its tray if the bin has been removed.*

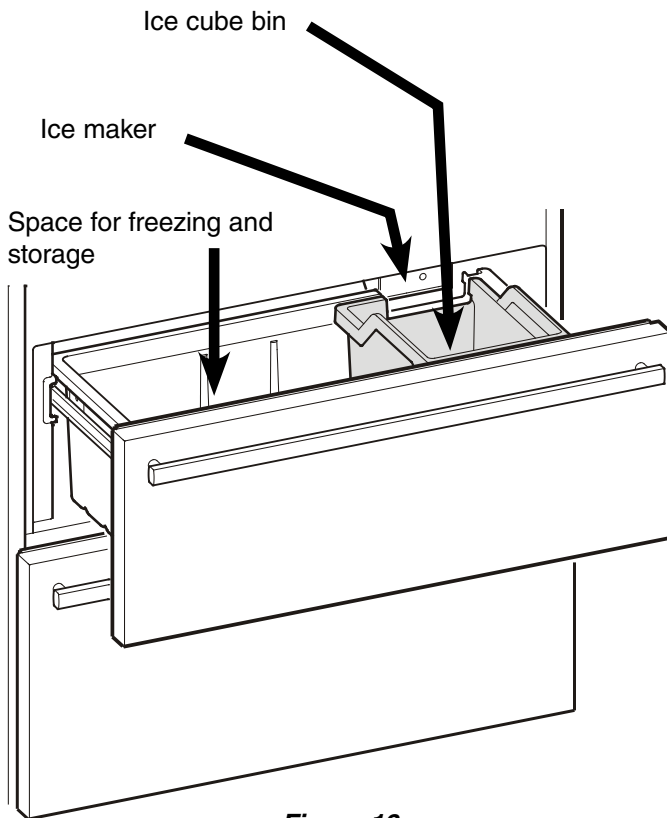

## Removing the Freezer Compartment Containers

The containers of both freezer drawers can be removed.

- Unlatch the container on the left and right corners by pulling upwards (1) - **Figure 17**.
- Slide the container backwards (2) - **Figure 17**.

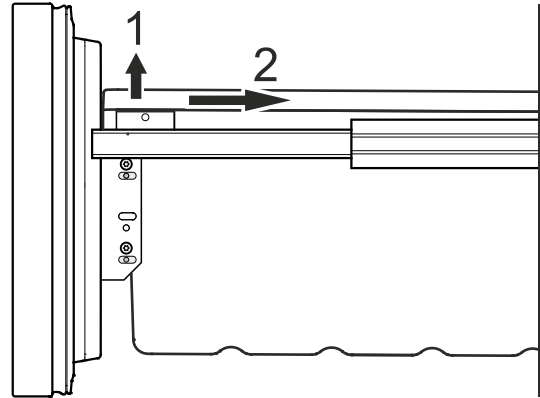

- Tilt the container at an angle and remove - **Figure 18**.

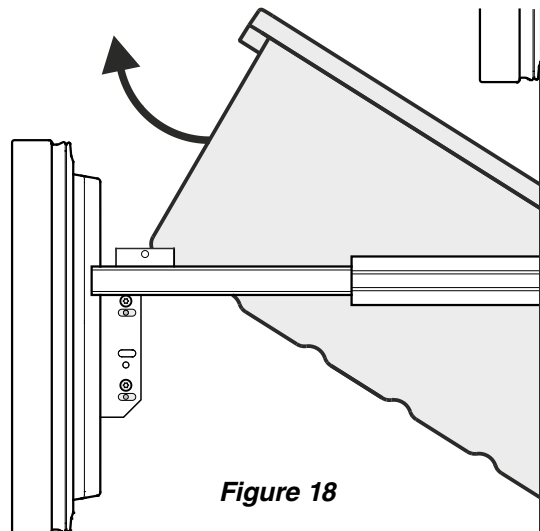

Install the container in the reverse order.

# FREEZER COMPARTMENT

## Freezing

Fresh food should be frozen completely and as rapidly as possible. This is provided by the Superfrost feature and ensures that the nutritional value, appearance and flavor of the food remains intact.

## Freezing with Superfrost - Figure 19

- Touch the Superfrost icon briefly so the LED \*\* turns on.
- Wait 24 hours.
- Then place the fresh food inside the freezer.
- The Superfrost function turns off automatically. Depending on the quantity of food placed in the freezer, this will normally be between 30 and maximum of 65 hours.

The freezing process is now complete; the Superfrost LED \*\* will turn off, and the freezer will change back to normal energy-saving operation.

### IMPORTANT

You should not turn on the Superfrost function:

- when placing frozen food in the freezer;
- when freezing up to approximately 4-1/2 lbs (2 kg) fresh food daily.

## Freezing and Storage

- Pack frozen food in standard freezer bags or reusable plastic, metal or aluminum containers.
- Do not allow fresh food which is to be frozen to come into contact with food already frozen. Always keep packages dry in order to avoid them sticking together.
- Always write the date and contents on the package and do not exceed the stated storage time for the food. This prevents spoiling.
- Pack food which you are freezing yourself in quantities right for your household. To ensure the food freezes right through quickly, the following quantities should not be exceeded per package:
  - fruit, vegetables: up to 2-1/4 lbs (1 kg);
  - meat: up to 5-1/2 lbs (2.5 kg).
- Do not freeze bottles and cans which contain carbonated drinks as they might burst. Drinks can be cooled down quickly, but take the bottles out of the freezer compartment after an hour at the most.
- Only take out as much food as needed for thawing. Cook food which has been thawed as quickly as possible. Frozen food can be thawed in the following ways:
  - in a microwave oven
  - in the refrigerator: the safer way to thaw food because there is less chance of bacteria growth. Use this method for high density food such as roasts or poultry.

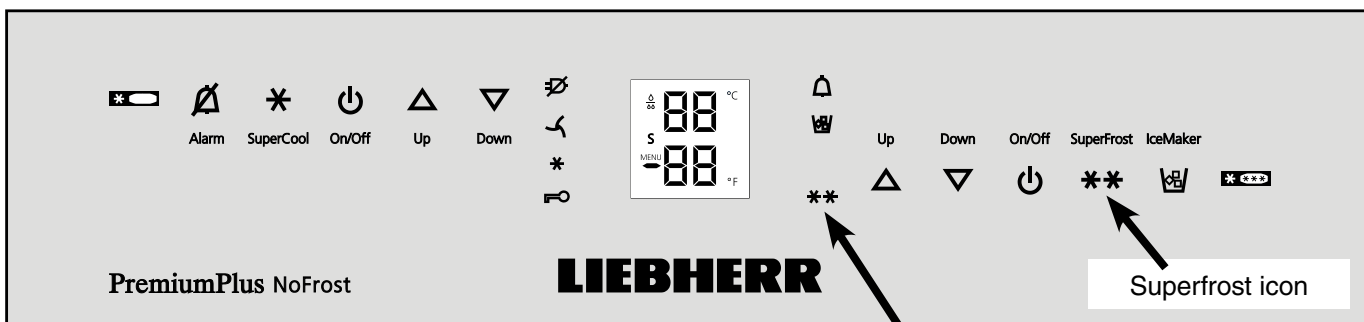

Figure 19

Superfrost LED

# ICEMAKER

## Safety Instructions and Warnings

- The Ice Maker is designed exclusively to make ice cubes in quantities needed by a household and may only be operated with water appropriate for this purpose.
- All repairs and work on the Ice Maker may only be done by customer service personnel or other appropriately trained personnel.
- **Do not consume or use the first three batches of ice. This applies both to using the appliance for the first time and also using it after it has not been used for a long period of time.**
- **The manufacturer cannot accept liability for damage caused by equipment or water lines between the solenoid valve and the water supply.**
- The Ice Maker will only work if the combined refrigerator-freezer is connected to the electrical outlet. It will only make ice cubes if the freezer compartment is operating.
- The Ice Maker can only make ice cubes if the upper freezer drawer is completely closed and the ice cube bin is installed correctly (**Figure 16**).

## Bleeding the Ice Maker

### IMPORTANT

To ensure a proper function of the Ice Maker the water pipe system must be purged of any air.

- Turn the Ice Maker on by touching the Ice Maker icon (**Figure 22**).
- Open the top freezer drawer.
- Press the button on the Ice Maker housing (**Figure 20**) for approx. 3 seconds. The LED above the button starts blinking.
- Press the button again briefly. The LED blinks faster.
- Close the top freezer drawer immediately.

The water intake of the appliance opens for 25 seconds and bleeds all air from the pipe system.

- After this the Ice Maker tray (**Figure 21**) must be emptied. Refer to chapter "Ice Maker at vacations".
- Finally clean the ice cube bin (**Figure 16**).

## To Start the Ice Maker

### To turn the Ice Maker on

- Touch the **Ice Maker icon** so the **Ice Maker LED** comes on (**Figure 22**).

After you start the Ice Maker for the first time it may take up to 24 hours before the first ice cubes are ready.

#### Note

*The first three batches of ice must not be consumed or used.*

The production capacity is 100 - 120 ice cubes in 24 hours at a temperature of 0°F inside the freezer compartment.

To have the maximum capacity of approx. 150 ice cubes in 24 hours, activate the Superfrost function.

**Be aware that this increases the energy consumption because the compressor will run constantly.**

The ice cubes fall out of the Ice Maker into the ice cube bin (**Figure 16**). When the ice reaches a certain level in the bin, the appliance stops producing ice automatically. The ice maker will not fill the bin to the top.

### To turn the Ice Maker off

If you do not need any ice cubes, the Ice Maker can be turned off independently of the freezer compartment.

- Touch the Ice Maker icon so the Ice Maker LED goes out.

#### Note

*The Ice Maker can also be turned on and off by pressing the "On/Off" button at the Ice Maker housing for approximately 1 second (**Figure 20**).*

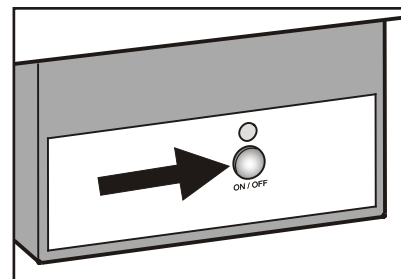
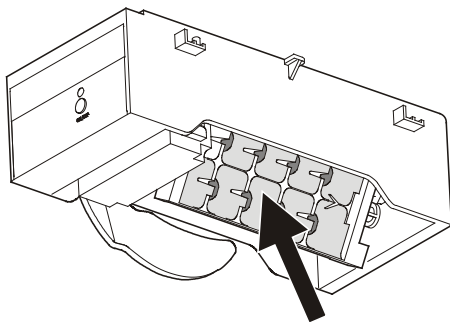

**Figure 20**

## Ice Maker at vacations

In case of longer vacations, the Ice Maker tray (arrow in **Figure 21**) should be emptied.

By setting the Ice Maker into the vacation state, the tray will rotate down and no water remains in the tray.



**Figure 21**

The freezer drawer must be left open, so the surface of the tray dries up and no mold or unpleasant odors can occur.

### How to activate the Ice Maker Vacation State

Be sure the upper freezer drawer is completely closed and the ice cube bin is installed correctly. (**Figure 16**).

1. Activate the setup mode by touching the **Superfrost** icon for 5 seconds.
2. Touch the **freezer compartment Down** icon until **!** appears in the freezer temperature display.
3. Touch the **Superfrost** icon
  - the display shows **!** or **!**
  - depending on the Ice Maker is turned on or off.
4. Touch the **freezer compartment Down** icon
  - the display shows **!**
5. Touch the **Superfrost** icon - the digit **!** flashes

The Ice Maker tray rotates down.

When the interior temperature appears in the display, the tray is in the down position (**Figure 21**) and the Ice Maker is turned off automatically.

### To turn the Ice Maker on

Touch the **Ice Maker icon** so the **Ice Maker LED** comes on.

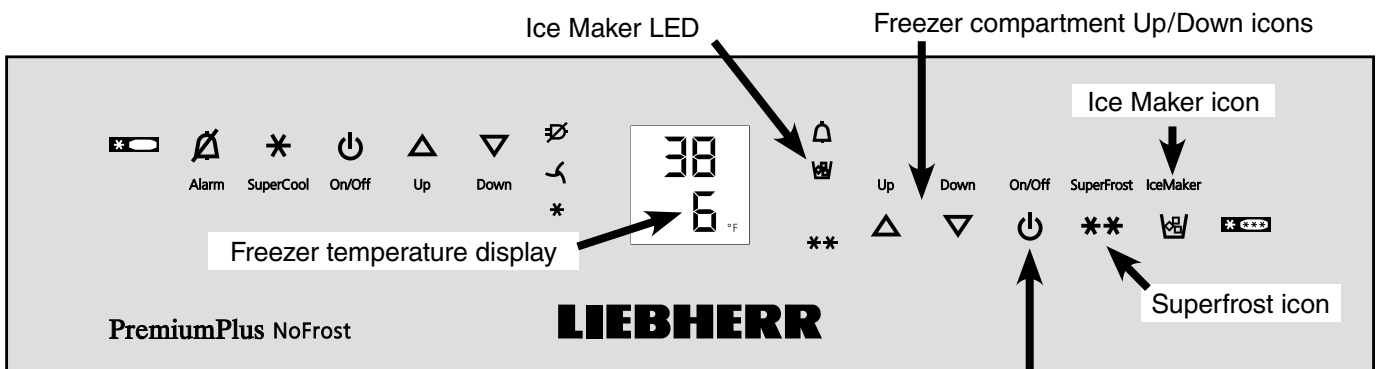

**Figure 22**

# CLEANING

---

## Cleaning

### WARNING

- **To prevent possible injury due to an electrical shock, be sure to disconnect the power cord or turn off the circuit breaker before cleaning the appliance.**
- **To avoid injury or damage, do not use steam cleaning equipment to clean the appliance.**

A compound of lukewarm water and dishwasher detergent is recommended for cleaning the appliance and equipment parts.

Use for stainless steel surfaces a good quality stainless steel cleaner only.

**Do not** use abrasive or scouring sponges. **Do not** use concentrated cleaning agents. **NEVER** use abrasive or acid cleaners or chemical solvents.

### WARNING

**To avoid short-circuits, ensure no cleaning water penetrates into the electrical components when cleaning the appliance. Do not use a sponge or cloth that is overly wet.**

- Remove all food from the refrigerator and freezer compartments and store on a cool place temporarily. Store frozen food in other freezers if available.
- Remove vegetable drawers as shown in **Figure 12**.
- Remove glass shelves as shown in **Figure 14**.
- Pull out the upper freezer drawer completely. Remove the ice cube bin by moving upwards. The position of the ice cube bin is shown in **Figure 16**.
- Remove the freezer drawer containers as shown in **Figure 17** and **Figure 18**.
- Clean the equipment parts by hand with lukewarm water and dishwasher detergent.

### CAUTION

**Do not clean the equipment parts in a dishwasher. Strips of these parts could get loose.**

- Clean the refrigerator and freezer drawers interior with lukewarm water and dishwasher detergent.
- Dry all parts well with a cloth.
- **Do not** damage or remove the model plate on the inside of the appliance. It is very important for servicing your appliance.

Keep your stainless steel looking new by cleaning with a good quality stainless steel cleaner or polish monthly. High quality stainless steel cleaners and conditioners are commercially available.

**Do not clean with steel wool pads or abrasive pads. Do not use cleaners that are not for use on stainless steel, such as glass, tile or counter cleaners. These types of cleaners can damage the surface permanently.**

Stainless steel that is exposed to chlorine gas and moisture may have some discoloration. This discoloration is normal. If your unit is used in this environment, clean and polish your stainless steel more often.

If the surface discolors or rusting appears, clean it quickly with a non-abrasive cloth and protect it. Always clean and polish in the direction of the grain and finish.

## Cleaning the Air Filter

- Open the bottom freezer drawer and unscrew the ventilation grille - **Figure 23**.

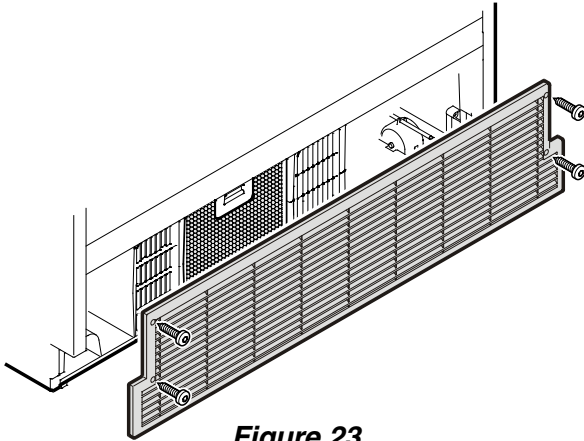

Figure 23

- Push down the button of the air filter, tilt to the front and remove - **Figure 24**.

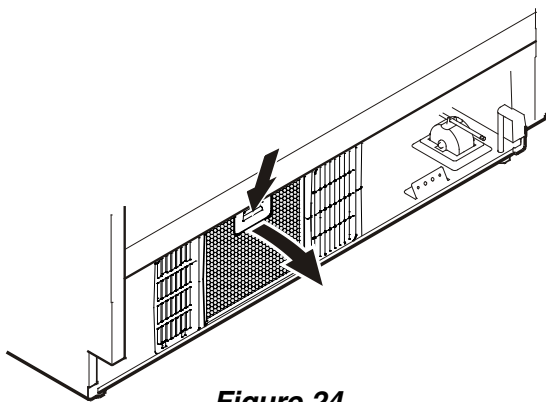

Figure 24

- Clean the filter in a dishwasher or by hand with lukewarm water and dishwasher detergent.
- Install the air filter in the reverse order.
- Install the ventilation grille.
- Install all equipment parts and replace the food in the appliance.
- Turn the appliance on.
- Reset the air filter LED.  
Refer to chapter **Setup Mode** - **⏏** = Reset air filter LED

## Defrosting

### Refrigerator compartment:

The refrigerator compartment defrosts automatically. The water that forms on the rear wall drains into a reservoir at the back of the appliance and evaporates automatically through the compressor heat.

### Freezer compartment:

The No-frost system automatically defrosts the freezer compartment. Any moisture will collect on the evaporator and freeze. It will periodically defrost and evaporate.

## Vacation Tips

### Short vacations:

It is not necessary to turn off the refrigerator and freezer if you will be away for less than four weeks.

- Use all perishables.
- Freeze other items.
- Turn off the ice maker.
- Shut off the water supply to the ice maker.

### Long vacations:

If you will be away for a month or more:

- Set the ice maker to the vacation state. Refer to chapter "Ice Maker at vacations".
- Remove all food from the refrigerator and freezer compartments.
- Turn off the refrigerator and freezer compartments.
- Clean the appliance. Refer to **Cleaning**.
- Leave the door open to prevent unpleasant odors. This will also keep mold from building up.
- Shut off the water supply to the ice maker.

# TROUBLESHOOTING

---

If a problem occurs during operation, check whether it is due to an operating error.

Please note that even during the warranty period, some repair costs may be your responsibility.

You may be able to correct the following faults by checking the possible causes yourself:

<b>Problem</b>	<b>Possible Cause and Remedy</b>
Appliance does not work, display is off	<ul style="list-style-type: none"><li>- Is the appliance turned on properly?</li><li>- Is the power source plug properly inserted in the socket?</li><li>- Is the circuit breaker or fuse in operating condition?</li></ul>
The interior light does not come on	<ul style="list-style-type: none"><li>- Is the refrigerator compartment turned on?</li><li>- Has the door been open for more than 15 minutes?</li></ul>
Loud running noise	<ul style="list-style-type: none"><li>- Is the appliance standing firmly on the floor, or does the compressor cause nearby items of furniture or objects to vibrate? If necessary, move the appliance slightly, align by adjusting the adjustable feet, or move bottles and containers apart.</li></ul>
Motor seems to run too long	<ul style="list-style-type: none"><li>- Is the ambient temperature too hot? See <b>Safety Regulations</b>.</li><li>- Has the appliance been opened too often or left open too long?</li><li>- A large amount of food has been added.</li><li>- Unit is in Supercooling mode. Verify unit is in normal operation mode.</li></ul>
The temperature is not cold enough	<ul style="list-style-type: none"><li>- Is the temperature setting correct? See <b>Setting the Temperature</b>.</li><li>- Has an excessive amount of fresh food been placed in the appliance?</li><li>- Does a separately installed thermometer show the correct reading?</li><li>- Is the ventilation system working properly?</li><li>- Is the appliance set up too close to a heat source?</li></ul>
Freezer temperature display shows two dashes “- -”.	<p>The freezer temperature display will only show temperatures that are below freezing. When initially starting the freezer it will not be below freezing. It will take three to five hours (depending on ambient conditions) for freezing temperatures to be achieved and thus displayed numerically.</p> <p>This may also occur after a power failure.</p>



# TROUBLESHOOTING

## Ice Maker Troubleshooting

You may be able to correct the following faults yourself:

If you are unable to repair the fault yourself or if the control lamp above the “On/Off” button flashes, contact our customer service department.

Problem	Possible Cause and Remedy
Ice Maker cannot be turned on	- Is the appliance connected to the electrical outlet?
Ice Maker is not making any ice	- Is the Ice Maker turned on? - Is the water supply line open? - Is the upper freezer drawer closed properly and the ice cube bin ( <b>Figure 16</b> ) installed correctly?

## Customer Service - Figure 25

If none of the above causes apply and you cannot correct the fault yourself this means there is a fault. Please contact your nearest customer service department (see enclosed list for addresses).

Give the **fault number displayed**, together with the

**Type Designation** ①,

**Service Number** ② and

**Appliance / serial number** ③

as given on the model plate, to ensure prompt, accurate servicing. The model plate is located inside the appliance on the left-hand side.

Leave the appliance closed until the customer service engineer arrives to prevent any further cold loss.

## Appliance Information

Record this information when the appliance is installed.

Type Designation: \_\_\_\_\_

Service Number: \_\_\_\_\_

Appliance / serial number: \_\_\_\_\_

Date of Purchase: \_\_\_\_\_

Where Purchased: \_\_\_\_\_

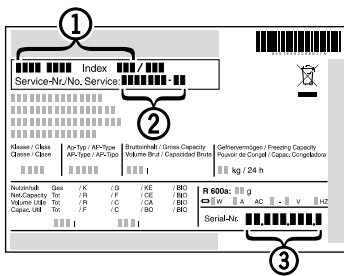

Figure 25

# WARRANTY

---

## LIEBHERR WARRANTY PLAN

### FULL TWO YEAR WARRANTY

For two years from the date of original purchase, your Liebherr warranty covers all parts and labor to repair or replace any part of the product which proves to be defective in materials or workmanship.

### FULL FIVE YEAR WARRANTY

For five years from the date of original purchase, your Liebherr warranty covers all parts and labor to repair or replace any components that prove to be defective in materials or workmanship in the sealed system. The “Sealed System” means only the compressor, condenser, evaporator, drier and all connecting tubing.

### LIMITED 6TH THROUGH 12TH YEAR WARRANTY

From the 6th through 12th year from the date of original purchase, your Liebherr warranty covers all parts that prove to be defective in materials or workmanship in the Sealed System (parts only).

### TERMS APPLICABLE TO EACH WARRANTY

All service provided by Liebherr under the warranty must be performed by authorized Liebherr service representatives, unless otherwise specified by Liebherr. Service will be provided in the home during normal business hours. This warranty applies only to products installed for normal residential use. Details regarding a non-residential warranty are available on request.

The warranty applies only to products installed in Canada and any one of the fifty states of the United States or the District of Columbia. This warranty does not cover any parts or labor to correct any defect caused by negligence, accident or improper use, maintenance, installation, service or repair, including but not limited to improper removal and reinstallation of the condensing unit.

**THE WARRANTIES DESCRIBED ABOVE ARE MADE EXPRESSLY IN LIEU OF ANY OTHER WARRANTIES, EXPRESSED OR IMPLIED, INCLUDING ANY IMPLIED WARRANTY OF MERCHANTABILITY OR FITNESS FOR A PARTICULAR PURPOSE, AND OF ANY OTHER OBLIGATION OR LIABILITY ON THE PART OF LIEBHERR. IN NO EVENT SHALL LIEBHERR BE LIABLE FOR SPECIAL, INCIDENTAL OR CONSEQUENTIAL DAMAGES ARISING FROM THE BREACH OF THESE WARRANTIES OR ANY OTHER WARRANTIES, WHETHER EXPRESS, IMPLIED OR STATUTORY.**

Some States do not allow the exclusion or limitation of incidental or consequential damages so the above limitation or exclusion may not apply to you. This warranty gives you specific legal rights and you may also have other rights which vary from State to State.

To receive parts and/or service and the name of the Liebherr authorized service representative nearest you, contact your Liebherr dealer or distributor or contact the Liebherr designated national service provider:

in the US: [Service-appliances.us@liebherr.com](mailto:Service-appliances.us@liebherr.com), or call 1-866-LIEBHER or 1-866-543-2437

in Canada: [www.euro-parts.ca](http://www.euro-parts.ca), or call 1-888-LIEBHER, 1-888-543-2437.