

## H 7870 BMX

30" handleless compact speed oven

in a perfectly combinable design with automatic programs and roast probe.



- Large touch display with proximity sensor – M Touch + MotionReact
- Easy cleaning – cavity with linen-weave pattern & PerfectClean
- Faster and more consistent results – Quick & Gentle
- Network-enabled WiFi appliance – Miele@home
- Popcorn in a flash with the popcorn function

EAN: 4002516780014 / Material number: 12397570 / Old Material Number: 22787086USA

Design	
Appliance color	Obsidian Black matte
Construction type and design	
Built-in wall speed oven	•
ArtLine	•
Handleless	•
Convenience features	
Quick & Gentle	•
Rapid PreHeat	•
Roast probe	wired
Keep-warm function	•
Crisp Function	•
Operating modes	
Defrost	•
MasterChef automatic programs	•
Auto roast	•
Broiling operating modes	•
Maxi Broil	•
Intensive Bake	•
Slow roast	•
Microwave	•
Combi Auto Roast	•
Micro Broil	•
Combi Bake	•
Combi Broil	•
Surround	•
Bake	•
Convection Roast	•
Special modes	•
User convenience	
Networking with Miele@home	•
Control panel	M Touch
MotionReact proximity sensor	•
MotionReact: Light comes on when movement is detected	•
MotionReact: Display comes on when movement is detected	•
MotionReact: Audible signal to acknowledge when movement is detected	•
MotionReact: Detection of cabinet fronts	•
SoftOpen	•
MultiLingua	•
MyMiele	•
Show me how	•
Popcorn function	•
Polyphonic acoustic signals	•
Time of day display	•
Time synchronization	•
Date display	•
Minute minder	•
Programming start of cooking duration	•

## H 7870 BMX

30" handleless compact speed oven

in a perfectly combinable design with automatic programs and roast probe.



EAN: 4002516780014 / Material number: 12397570 / Old Material Number: 22787086USA

Programming end of cooking duration	•
Programmable cooking time	•
Actual temperature display	•
Audible signal when desired temperature is reached	•
Default temperature	•
Recommended microwave power	•
Minute Plus button	•
Favorites	•
Individual settings	•
<b>Efficiency and sustainability</b>	
Automatic residual heat utilization	•
<b>Cleaning convenience</b>	
Stainless-steel cavity with linen surface structure	•
Foldable broil heater element	•
CleanGlass door	•
<b>Safety</b>	
Appliance cooling system and cool touch front	•
Safety cut-out	•
System lock	•
Sensor lock	•
<b>Technical data</b>	
Cavity volume in cu.ft (l)	1.52 (43)
No. of rack levels	3
Number of shelf levels oven compartment 1	3
Number of shelf levels oven compartment 2	3
Oven interior lighting	1 LED spot
Temperatures in °F (°C)	85-475 (30-250)
Electronically controlled microwave power	•
Microwave power levels	1 - 7
Niche dimensions (W x H x D) in inches (mm)	28 5/8 (724)-28 5/8 (724) x 18 5/8 (470)-18 5/8 (472) x 24 1/8 (610)
Niche width min. in inches (mm)	28 5/8 (724)
Niche width max. in inches (mm)	28 5/8 (724)
Niche height min. in inches (mm)	18 5/8 (470)
Niche height max. in inches (mm)	18 5/8 (472)
Niche depth in in. (mm)	24 1/8 (610)
Appliance dimensions (W x H x D) in inches (mm)	29 7/8 (757) x 18 7/8 (479) x 22 5/8 (573)
Appliance width in in. (mm)	29 7/8 (757)
Appliance height in in. (mm)	18 7/8 (479)
Appliance depth in in. (mm)	22 5/8 (573)
Weight in lbs. (kg)	100.31 (45.5)
Total connected load in kW	4.00
Power Rating in V	120
Voltage in V	240/208
Frequency in Hz	60
Fuse rating in A	30
Number of phases	1
Connection wire with plug	•
Length of power cord in in. (m)	1.80

## H 7870 BMX

30" handleless compact speed oven

in a perfectly combinable design with automatic programs and roast probe.



EAN: 4002516780014 / Material number: 12397570 / Old Material Number: 22787086USA

### Standard accessories

Wire rack with PerfectClean

1

Glass tray

2

### Available display languages

Available display languages via MultiLingua

bahasa malaysia, dansk,  
deutsch, english, español,  
français, hrvatski, italiano,  
magyar, nederlands,  
norsk, polski, português,  
русский, română,  
slovenčina, slovenščina,  
srpski, suomi, svenska,  
türkçe, українська, čeština,  
ελληνικά,

## H 7870 BMX

30" handleless compact speed oven

in a perfectly combinable design with automatic programs and roast probe.

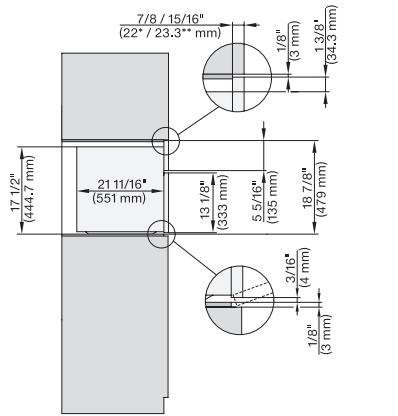

side view 30 inch Flush inset BM30, installation drawing, NA

7/8" – 22" mm – Glas, 15/16" – 23.3\*\* mm – Edelstahl

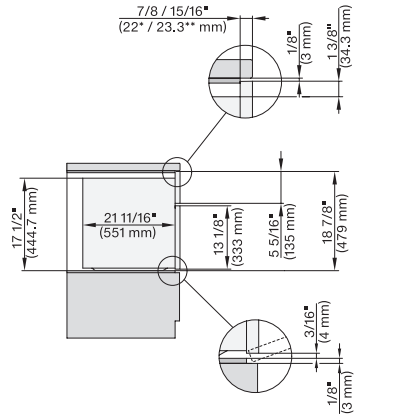

side view 30 inch Flush inset built-under BM30, installation drawing, NA

7/8" – 22" mm – Glas, 15/16" – 23.3\*\* mm – Edelstahl

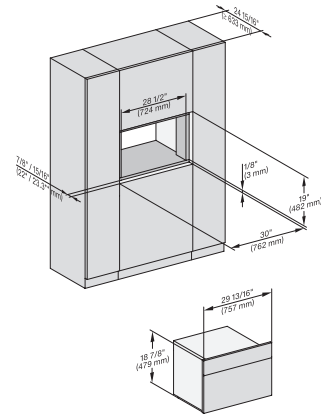

installation 30 inch Flush inset BM30, installation drawing, NA

7/8" – 22" mm – Glas, 15/16" – 23.3\*\* mm – Edelstahl

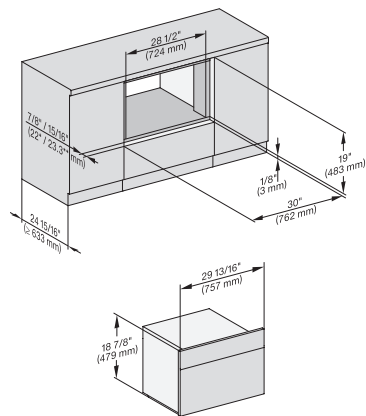

installation 30 Zoll Flush inset built-under BM30, installation drawing, NA

7/8" – 22" mm – Glas, 15/16" – 23.3\*\* mm – Edelstahl

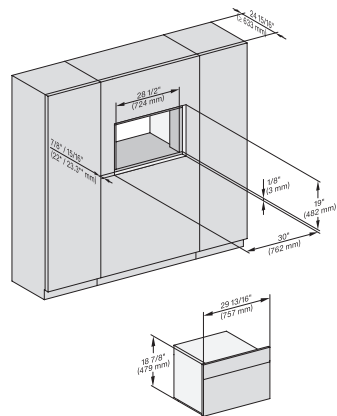

installation 30 inch Flush inset wide front BM30, installation drawing, NA

7/8" – 22" mm – Glas, 15/16" – 23.3\*\* mm – Edelstahl

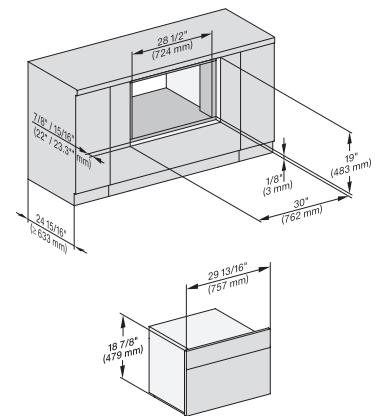

installation 30 inch Flush inset built-under wide front BM30, installation drawing, NA

7/8" – 22" mm – Glas, 15/16" – 23.3\*\* mm – Edelstahl

## H 7870 BMX

30" handleless compact speed oven

in a perfectly combinable design with automatic programs and roast probe.

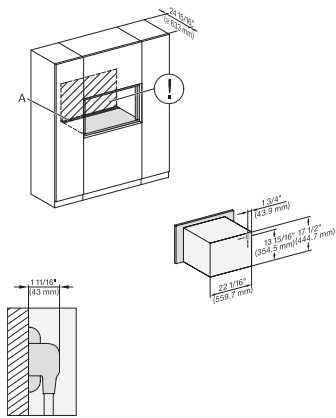

installation 30 inch Flush inset BM30, installation drawing, NA

A – Cut-out (4" x 28" / 100 mm x 720 mm) in the bottom of the cabinet for power cord and ventilation. – Electrical and water supplies are recommended to be placed in adjacent cabinetry. Additional cabinet depth is required when placing the electrical and water supplies behind the appliance. E = Electric connection

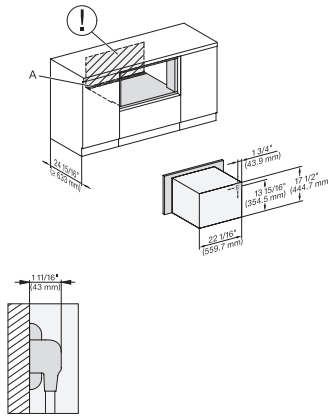

installation 30 inch Flush inset built-under BM30, installation drawing, NA

A – Cut-out (4" x 28" / 100 mm x 720 mm) in the bottom of the cabinet for power cord and ventilation. – Electrical and water supplies are recommended to be placed in adjacent cabinetry. Additional cabinet depth is required when placing the electrical and water supplies behind the appliance. E = Electric connection

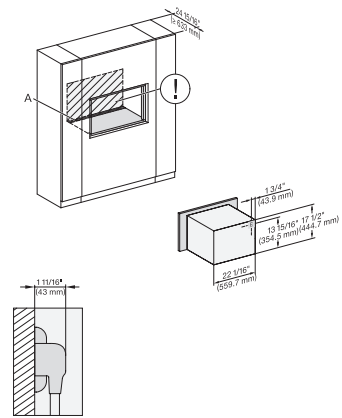

installation 30 inch Flush inset wide front BM30, installation drawing, NA

A – Cut-out (4" x 28" / 100 mm x 720 mm) in the bottom of the cabinet for power cord and ventilation. – Electrical and water supplies are recommended to be placed in adjacent cabinetry. Additional cabinet depth is required when placing the electrical and water supplies behind the appliance. E = Electric connection

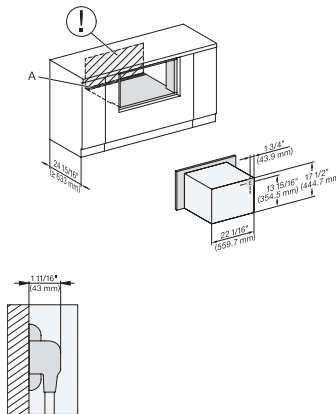

installation 30 inch Flush inset built-under wide front BM30, installation drawing, NA

A – Cut-out (4" x 28" / 100 mm x 720 mm) in the bottom of the cabinet for power cord and ventilation. – Electrical and water supplies are recommended to be placed in adjacent cabinetry. Additional cabinet depth is required when placing the electrical and water supplies behind the appliance. E = Electric connection

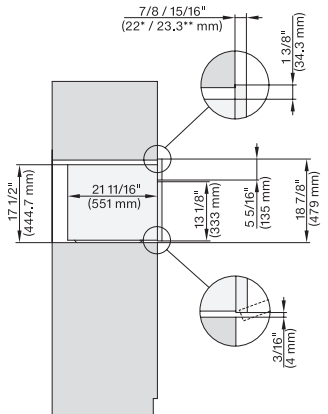

side view 30 inch Proud BM30, installation drawing, NA

7/8" – 22" mm – Glas, 15/16" – 23.3\*\* mm – Edelstahl

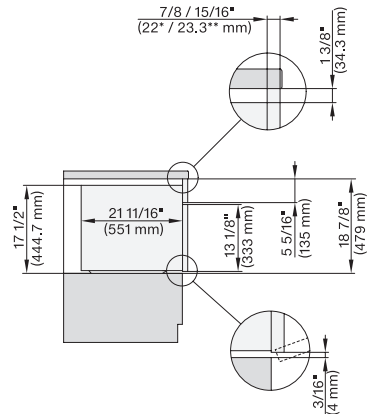

side view 30 inch Proud built-under BM30, installation drawing, NA

7/8" – 22" mm – Glas, 15/16" – 23.3\*\* mm – Edelstahl

## H 7870 BMX

30" handleless compact speed oven

in a perfectly combinable design with automatic programs and roast probe.

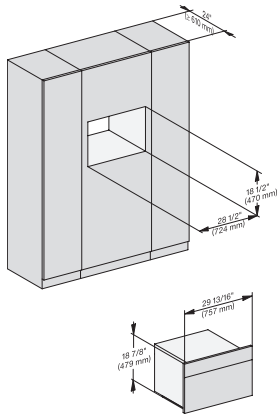

installation 30 inch Proud BM30, installation drawing, NA

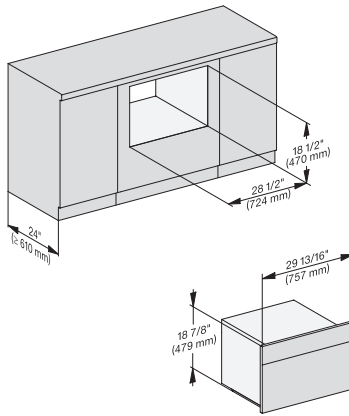

installation 30 inch Proud built-under BM30, installation drawing, NA

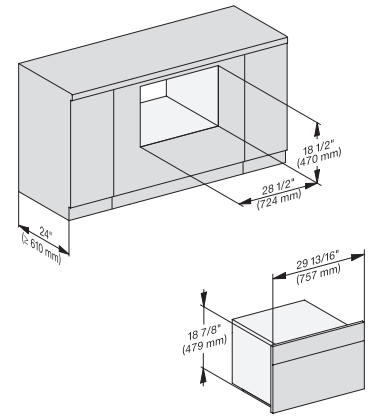

installation 30 inch Proud built-under wide front BM30, installation drawing, NA

7/8" – 22" mm – Glas, 15/16" – 23.3" mm – Edelstahl

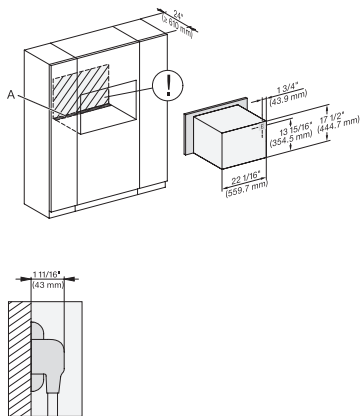

installation 30 inch Proud BM30, installation drawing, NA

A – Cut-out (4" x 28" / 100 mm x 720 mm) in the bottom of the cabinet for power cord and ventilation. – Electrical and water supplies are recommended to be placed in adjacent cabinetry. Additional cabinet depth is required when placing the electrical and water supplies behind the appliance. E = Electric connection

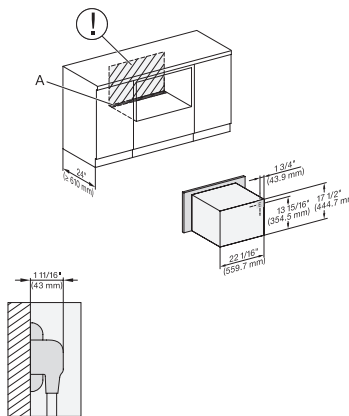

installation 30 inch Proud built-under BM30, installation drawing, NA

A – Cut-out (4" x 28" / 100 mm x 720 mm) in the bottom of the cabinet for power cord and ventilation. – Electrical and water supplies are recommended to be placed in adjacent cabinetry. Additional cabinet depth is required when placing the electrical and water supplies behind the appliance. E = Electric connection,

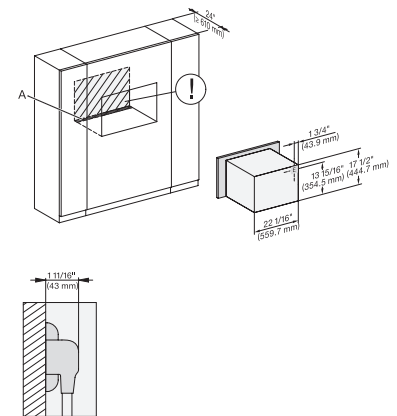

installation 30 inch Proud wide front BM30, installation drawing, NA

A – Cut-out (4" x 28" / 100 mm x 720 mm) in the bottom of the cabinet for power cord and ventilation. – Electrical and water supplies are recommended to be placed in adjacent cabinetry. Additional cabinet depth is required when placing the electrical and water supplies behind the appliance. E = Electric connection

## H 7870 BMX

30" handleless compact speed oven

in a perfectly combinable design with automatic programs and roast probe.

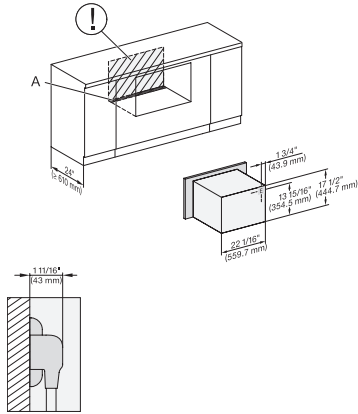

installation 30Zoll Proud built-under wide front BM30, installation drawing, NA

A – Cut-out (4" x 28" / 100 mm x 720 mm) in the bottom of the cabinet for power cord and ventilation. – Electrical and water supplies are recommended to be placed in adjacent cabinetry. Additional cabinet depth is required when placing the electrical and water supplies behind the appliance. E = Electric connection.

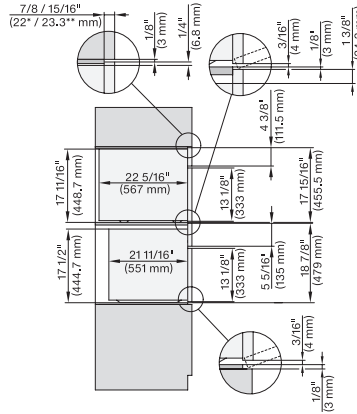

DGC 6x00-1 + EBA 6808, H 6xx0 DWM, DGC 7xxx, H7xxx, EBA 7848 Combi, Installation drawing, Flush inset, NA

7/8" – 22" mm – Glas, 15/16" – 23.3" mm – Edelstahl

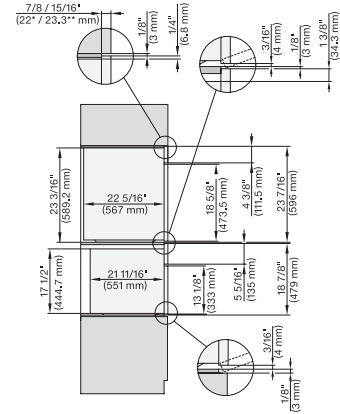

DGC 6x6x (AM) + EBA 6808, H 6x70 BM, DGC786x, EBA7868, H7xxx Combi, Installation drawing, Flush inset, NA

7/8" – 22" mm – Glas, 15/16" – 23.3" mm – Edelstahl

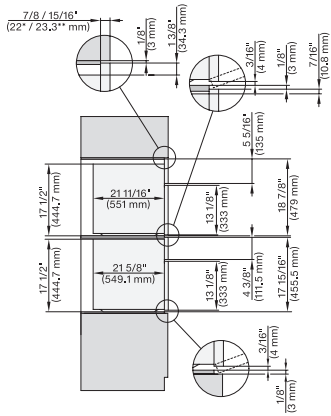

H 6x70 BM, H 6x00 BM + EBA 6808, H 7xxx, EBA 7848 Combi, Installation drawing, Flush inset, NA

7/8" – 22" mm – Glas, 15/16" – 23.3" mm – Edelstahl

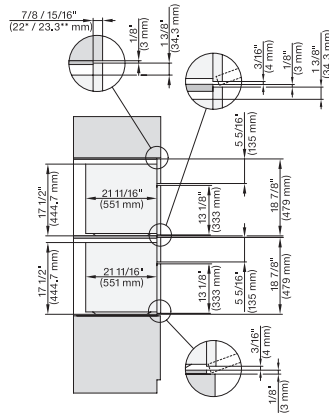

H 6x70 BM, H 7x70, Combi, Installation drawing, Flush inset, NA

7/8" – 22" mm – Glas, 15/16" – 23.3" mm – Edelstahl

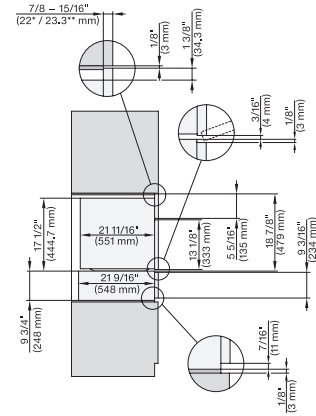

H 6x70 BM, ESW 6x85, H7x70, ESW 7x70, EVS 7670 Combi, Installation drawing, Flush inset, NA

7/8" – 22" mm – Glas, 15/16" – 23.3" mm – Edelstahl

## H 7870 BMX

30" handleless compact speed oven

in a perfectly combinable design with automatic programs and roast probe.

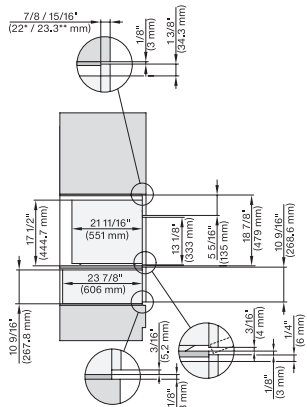

H 6x70 BM, ESW 6x80, H 7x70, ESW 7x80 Combi, Installation drawing, Flush inset, NA  
7/8" – 22" mm – Glas, 15/16" – 23.3" mm – Edelstahl

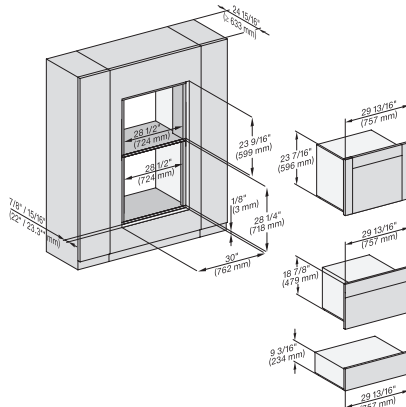

(H6560 B, H6x60 BP, H6x70 BM, DGC686x AM) + EBA6808; ESW6x85, DGC676x, DGC7xxx, EBA7868, H 7x70BM/BMX, ESW, EVS, NA

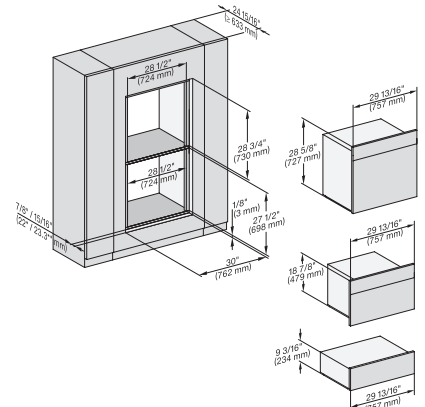

H 6x80 BP, H 6x70 BM, ESW 6x85, H 6x80-2BP, H2x80BP, H7xx0BP/BM/BPX, ESW7x70, EVS7670 Flush inset, NA

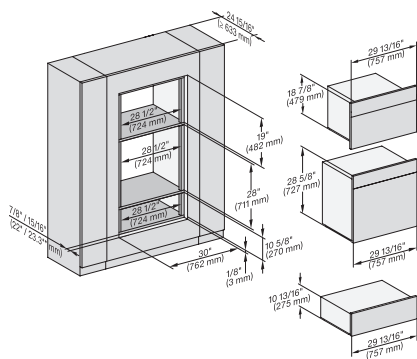

H 6x80 BP, H 6x70 BM, ESW 6x80, H 6x80-2BP, DGC7x7x, H7xxxBM/BMX/BP, H2xxxBP, ESW7xxx, NA

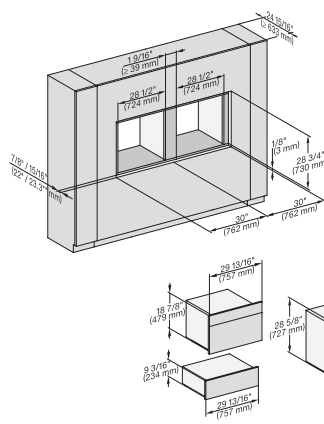

H 6x80 BP, H 6x70 BM, ESW 6x85, H 6x80-2BP, H7x70BM/BMX, ESW 7x70, EVS 7670, Installation drawing, Flush inset, NA

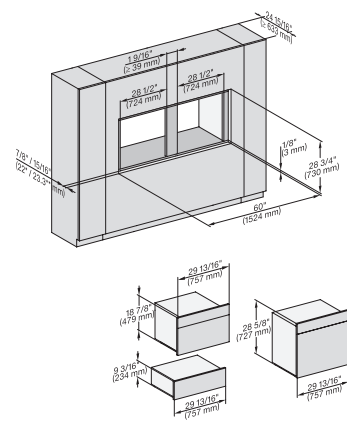

H 6x80 BP, H 6x70 BM, ESW 6x85, H 6x80-2BP, H7x80 BP/BPX/BM/BMX, EWS 7x70, EVS 7670 drawing, Flush inset, NA

## H 7870 BMX

30" handleless compact speed oven

in a perfectly combinable design with automatic programs and roast probe.

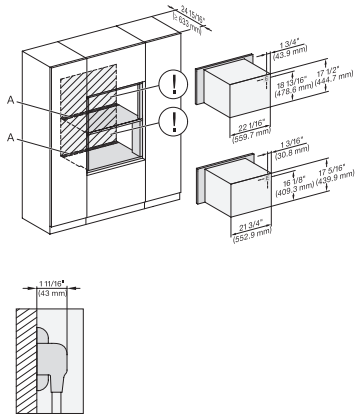

H 6x70 BM, H 6x00 BM + EBA 6808, H7xxx BM/BMX + EBA 7848 Installation Combi, Installation drawing, Flush inset, NA

A – Cut-out (4" x 28" / 100 mm x 720 mm) in the bottom of the cabinet for power cord and ventilation. – Electrical and water supplies are recommended to be placed in adjacent cabinetry. Additional cabinet depth is required when placing the electrical and water supplies behind the appliance. E = Electric connection

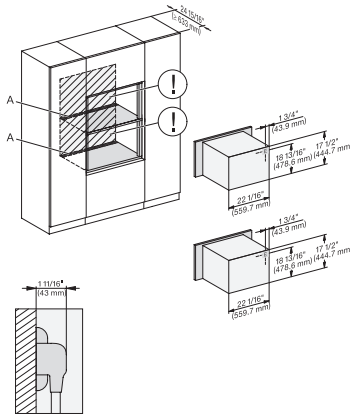

H 6x70 BM, H 7x70 BM/BMX Installation Combi, Installation drawing, Flush inset, NA

A – Cut-out (4" x 28" / 100 mm x 720 mm) in the bottom of the cabinet for power cord and ventilation. – Electrical and water supplies are recommended to be placed in adjacent cabinetry. Additional cabinet depth is required when placing the electrical and water supplies behind the appliance. E = Electric connection

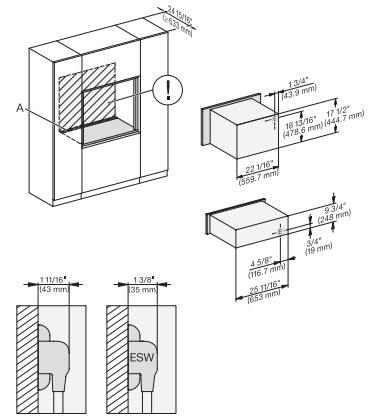

H 6x70 BM, ESW 6x85, H 7x70 BM/BMX, ESW 7x70, EVS 7670 Installation Combi, Installation drawing, Flush inset, NA

A – Cut-out (4" x 28" / 100 mm x 720 mm) in the bottom of the cabinet for power cord and ventilation. – Electrical and water supplies are recommended to be placed in adjacent cabinetry. Additional cabinet depth is required when placing the electrical and water supplies behind the appliance. E = Electric connection

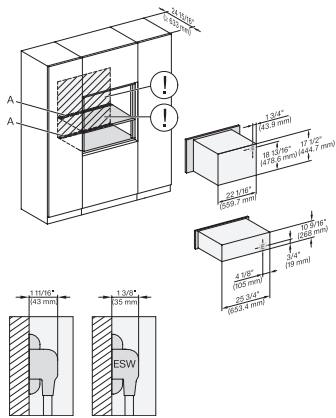

H 6x70 BM, ESW 6x80, H 7x70 BM/BMX, ESW 7x80 Installation Combi, Installation drawing, Flush inset, NA

A – Cut-out (4" x 28" / 100 mm x 720 mm) in the bottom of the cabinet for power cord and ventilation. – Electrical and water supplies are recommended to be placed in adjacent cabinetry. Additional cabinet depth is required when placing the electrical and water supplies behind the appliance. E = Electric connection

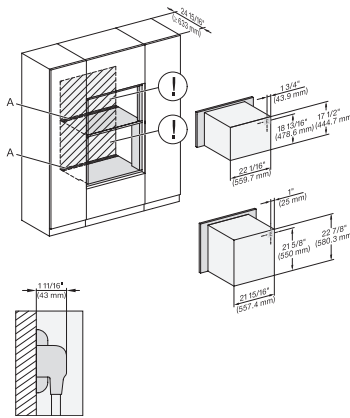

H 6560B, EBA 6808, H 6x60BP, H 6x70BM, H 7xxxBM/BMX, EBA 7868 Installation Combi, Installation drawing, Flush inset, NA

A – Cut-out (4" x 28" / 100 mm x 720 mm) in the bottom of the cabinet for power cord and ventilation. – Electrical and water supplies are recommended to be placed in adjacent cabinetry. Additional cabinet depth is required when placing the electrical and water supplies behind the appliance. E = Electric connection

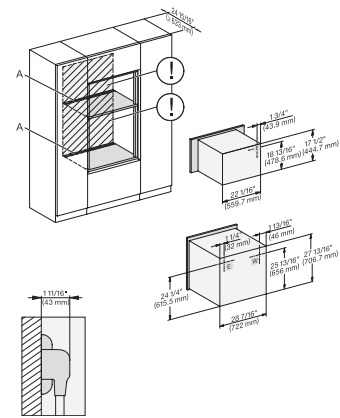

H 6x80 BP, H 6x70 BM, H 6x80-2BP, H 7xxx BM/BMX/BP/BPX, H 2x90BP Installation drawing, Flush inset, NA

A – Cut-out (4" x 28" / 100 mm x 720 mm) in the bottom of the cabinet for power cord and ventilation. – Electrical and water supplies are recommended to be placed in adjacent cabinetry. Additional cabinet depth is required when placing the electrical and water supplies behind the appliance. E = Electric connection

## H 7870 BMX

30" handleless compact speed oven

in a perfectly combinable design with automatic programs and roast probe.

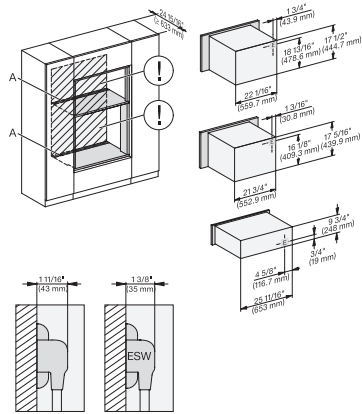

H 6x70 BM, H 6x00 BM + EBA 6808, ESW 6x85, H7xxxBM/BMX, EBA 7848, ESW7x70, EVS7670 Installation drawing, Flush inset, NA

A – Cut-out (4" x 28" / 100 mm x 720 mm) in the bottom of the cabinet for power cord and ventilation. – Electrical and water supplies are recommended to be placed in adjacent cabinetry., Additional cabinet depth is required when placing the electrical and water supplies behind the appliance., E = Electric connection

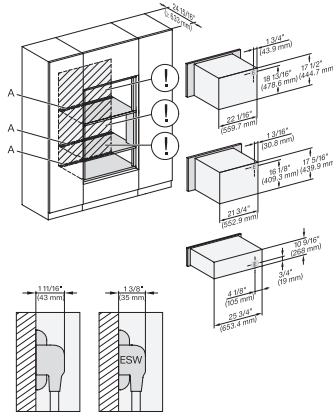

H 6x70 BM, H 6x00 BM + EBA 6808, ESW 6x80, H 7xxxBM/BMX, EBA 7848, ESW 7x80, Installation drawing, Flush inset, NA

A – Cut-out (4" x 28" / 100 mm x 720 mm) in the bottom of the cabinet for power cord and ventilation. – Electrical and water supplies are recommended to be placed in adjacent cabinetry., Additional cabinet depth is required when placing the electrical and water supplies behind the appliance., E = Electric connection

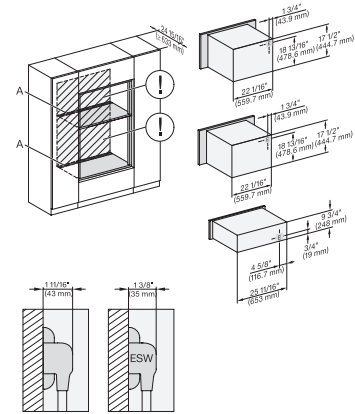

H 6x70 BM, ESW 6x85, H7x70 BM/BMX, ESW 7x70, EVS 7670 Installation Combi, Installation drawing, Flush inset, NA

A – Cut-out (4" x 28" / 100 mm x 720 mm) in the bottom of the cabinet for power cord and ventilation. – Electrical and water supplies are recommended to be placed in adjacent cabinetry., Additional cabinet depth is required when placing the electrical and water supplies behind the appliance., E = Electric connection

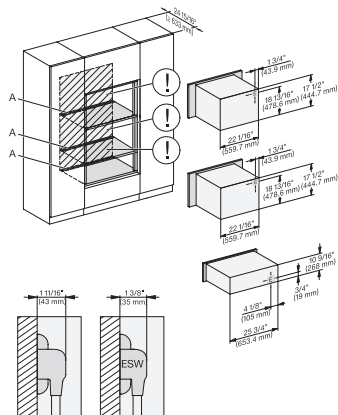

H 6x70 BM, ESW 6x80, H 7x70BM/BMX, ESW 7x80 Installation Combi, Installation drawing, Flush inset, NA

A – Cut-out (4" x 28" / 100 mm x 720 mm) in the bottom of the cabinet for power cord and ventilation. – Electrical and water supplies are recommended to be placed in adjacent cabinetry., Additional cabinet depth is required when placing the electrical and water supplies behind the appliance., E = Electric connection

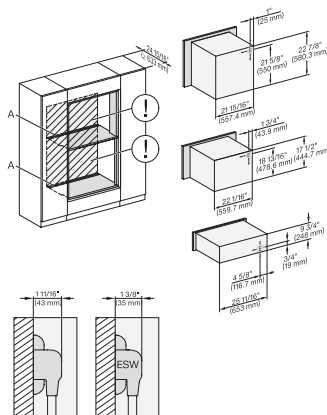

H 6x60 B/BP, EBA 6808, H 6x70 BM, ESW 6x85, H7xxxBP/BM/BMX, ESW7x70, EVS7670 Installation drawing, Flush inset, NA

A – Cut-out (4" x 28" / 100 mm x 720 mm) in the bottom of the cabinet for power cord and ventilation. – Electrical and water supplies are recommended to be placed in adjacent cabinetry., Additional cabinet depth is required when placing the electrical and water supplies behind the appliance., E = Electric connection

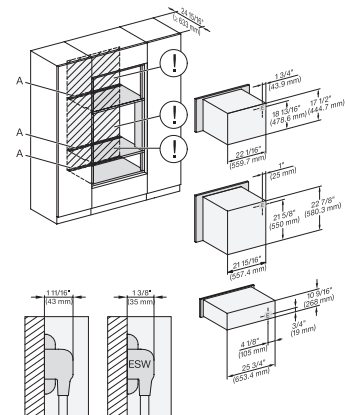

H 6x60 B/BP + EBA 6808, H 6x70 BM, ESW 6x80, H 7xxxBP/BM/BMX, EBA 7868, ESW 7x80 Installation drawing, Flush inset, NA

A – Cut-out (4" x 28" / 100 mm x 720 mm) in the bottom of the cabinet for power cord and ventilation. – Electrical and water supplies are recommended to be placed in adjacent cabinetry., Additional cabinet depth is required when placing the electrical and water supplies behind the appliance., E = Electric connection

## H 7870 BMX

30" handleless compact speed oven

in a perfectly combinable design with automatic programs and roast probe.

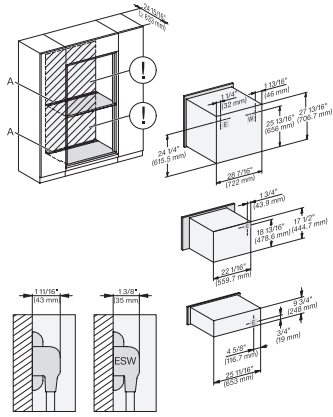

H 6x80 BP, H 6x70 BM, ESW 6x85, H 6x80-2BP, H2880BP, H7xxxBP/BPX/BM/BMX, Exx7670, Installation drawing, Flush inset, NA

A – Cut-out (4" x 28" / 100 mm x 720 mm) in the bottom of the cabinet for power cord and ventilation. – Electrical and water supplies are recommended to be placed in adjacent cabinetry. Additional cabinet depth is required when placing the electrical and water supplies behind the appliance. E = Electric connection

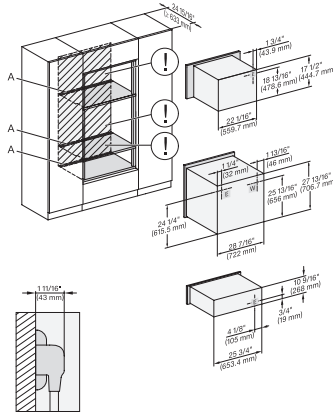

H 6x80BP, H 6x70 BM, ESW 6x80, H 6x80-2BP, H 2880BP, H 7xxxBP/BPX/BM/BMX, ESW 7x80 Installation drawing, Flush inset, NA

A – Cut-out (4" x 28" / 100 mm x 720 mm) in the bottom of the cabinet for power cord and ventilation. – Electrical and water supplies are recommended to be placed in adjacent cabinetry. Additional cabinet depth is required when placing the electrical and water supplies behind the appliance. E = Electric connection

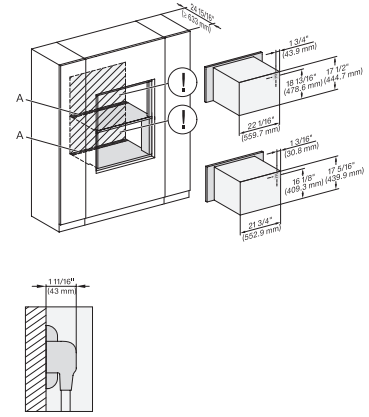

H 6x70 BM, H 6x00 BM + EBA 6808, H7xxxBM/BMX, EBA 7848, Installation drawing, Flush inset, NA

A – Cut-out (4" x 28" / 100 mm x 720 mm) in the bottom of the cabinet for power cord and ventilation. – Electrical and water supplies are recommended to be placed in adjacent cabinetry. Additional cabinet depth is required when placing the electrical and water supplies behind the appliance. E = Electric connection

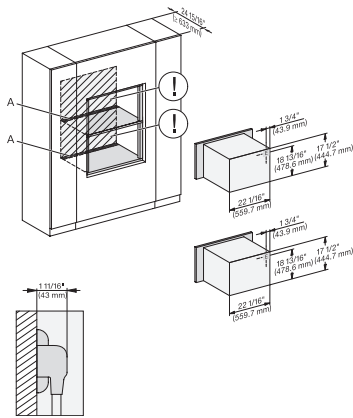

H 6x70 BM, H 7x70BM/BMX Installation Combi wide front, Installation drawing, Flush inset, NA

A – Cut-out (4" x 28" / 100 mm x 720 mm) in the bottom of the cabinet for power cord and ventilation. – Electrical and water supplies are recommended to be placed in adjacent cabinetry. Additional cabinet depth is required when placing the electrical and water supplies behind the appliance. E = Electric connection

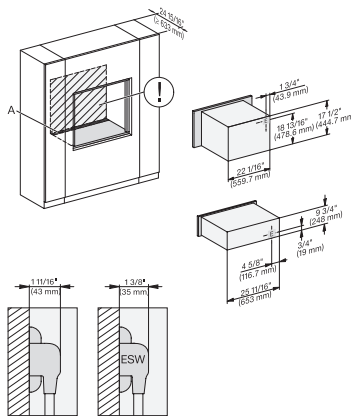

H 6x70 BM, ESW 6x85, H 7x70BM/BMX, ESW 7x70, EVS 7670, Installation drawing, Flush inset, NA

A – Cut-out (4" x 28" / 100 mm x 720 mm) in the bottom of the cabinet for power cord and ventilation. – Electrical and water supplies are recommended to be placed in adjacent cabinetry. Additional cabinet depth is required when placing the electrical and water supplies behind the appliance. E = Electric connection

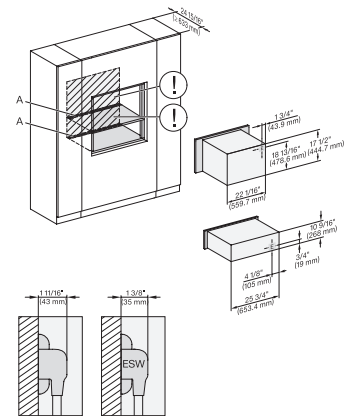

H 6x70 BM, ESW 6x80, H 7x70BM/BMX, ESW 7x80, Installation Combi wide front, Installation drawing, Flush inset, NA

A – Cut-out (4" x 28" / 100 mm x 720 mm) in the bottom of the cabinet for power cord and ventilation. – Electrical and water supplies are recommended to be placed in adjacent cabinetry. Additional cabinet depth is required when placing the electrical and water supplies behind the appliance. E = Electric connection

## H 7870 BMX

30" handleless compact speed oven

in a perfectly combinable design with automatic programs and roast probe.

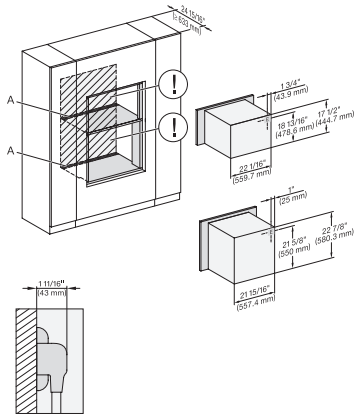

H 6560 B + EBA 6808, H 6x60 BP, H 6x70 BM, H 7xxxBM/BP/BMX, EBA 7868 Installation drawing, Flush inset, NA

A – Cut-out (4" x 28" / 100 mm x 720 mm) in the bottom of the cabinet for power cord and ventilation. – Electrical and water supplies are recommended to be placed in adjacent cabinetry. Additional cabinet depth is required when placing the electrical and water supplies behind the appliance. E = Electric connection

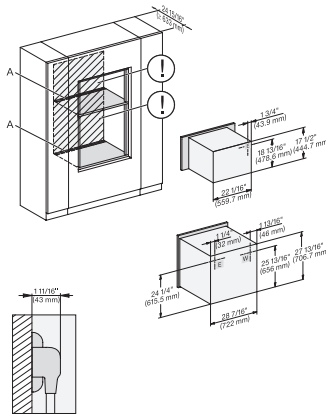

H 6x80 BP, H 6x70 BM, H 6x80-2BP, H 2x80BP, H 7x8xBP/BPX Installation drawing, Flush inset, NA

A – Cut-out (4" x 28" / 100 mm x 720 mm) in the bottom of the cabinet for power cord and ventilation. – Electrical and water supplies are recommended to be placed in adjacent cabinetry. Additional cabinet depth is required when placing the electrical and water supplies behind the appliance. E = Electric connection

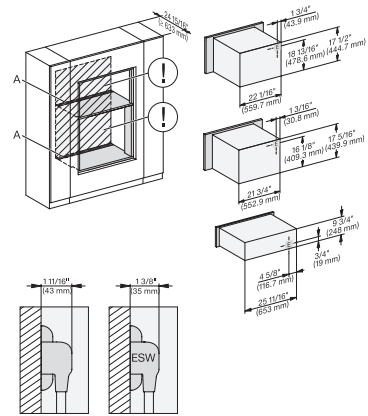

H 6x70BM, H 6x00BM, EBA 6808, ESW 6x85, H 7xxx BM/BMX, EBA 7848, ESW 7x70, EVS 7670 Installation drawing, Flush inset, NA

A – Cut-out (4" x 28" / 100 mm x 720 mm) in the bottom of the cabinet for power cord and ventilation. – Electrical and water supplies are recommended to be placed in adjacent cabinetry. Additional cabinet depth is required when placing the electrical and water supplies behind the appliance. E = Electric connection

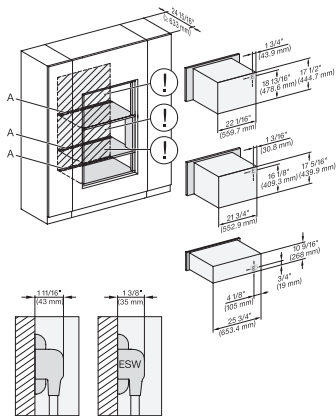

H 6x70 BM, H 6x00 BM + EBA 6808, ESW 6x80, H 7xxx BM/BMX, EBA 7848, ESW 7x80, Installation drawing, Flush inset, NA

A – Cut-out (4" x 28" / 100 mm x 720 mm) in the bottom of the cabinet for power cord and ventilation. – Electrical and water supplies are recommended to be placed in adjacent cabinetry. Additional cabinet depth is required when placing the electrical and water supplies behind the appliance. E = Electric connection

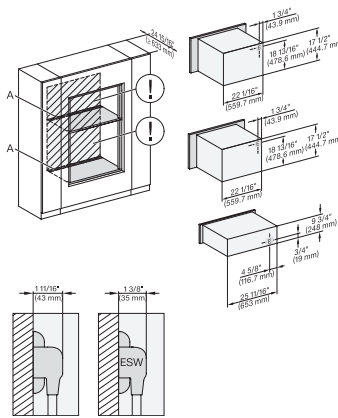

H 6x70 BM, ESW 6x85, H 7x70 BM/BMX, ESW 7x70, EVS 7670, Installation drawing, Flush inset, NA

A – Cut-out (4" x 28" / 100 mm x 720 mm) in the bottom of the cabinet for power cord and ventilation. – Electrical and water supplies are recommended to be placed in adjacent cabinetry. Additional cabinet depth is required when placing the electrical and water supplies behind the appliance. E = Electric connection

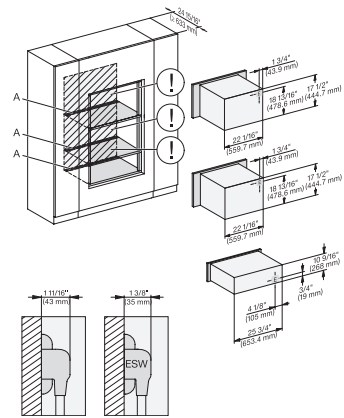

H 6x70 BM, ESW 6x80, H 7x70 BM/BMX, ESW 7x80, Installation drawing, Flush inset, NA

A – Cut-out (4" x 28" / 100 mm x 720 mm) in the bottom of the cabinet for power cord and ventilation. – Electrical and water supplies are recommended to be placed in adjacent cabinetry. Additional cabinet depth is required when placing the electrical and water supplies behind the appliance. E = Electric connection

## H 7870 BMX

30" handleless compact speed oven

in a perfectly combinable design with automatic programs and roast probe.

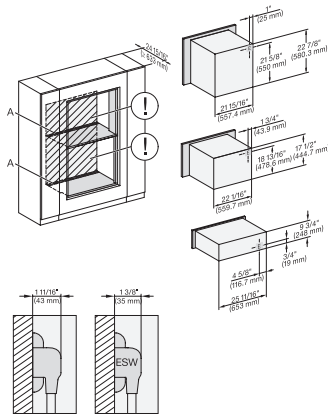

H 6560 B + EBA 6808, H 6x60 BP + EBA 6808, H 6x70 BM, ESW 6x85, H 7xxx BP/BM/BMX, EBA 7868, Exx 7x70, Flush inset, NA

A – Cut-out (4" x 28" / 100 mm x 720 mm) in the bottom of the cabinet for power cord and ventilation. – Electrical and water supplies are recommended to be placed in adjacent cabinetry., Additional cabinet depth is required when placing the electrical and water supplies behind the appliance., E = Electric connection

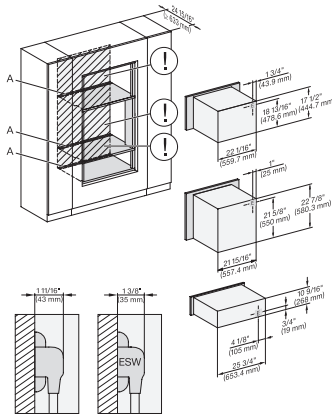

H 6560 B + EBA 6808, H 6x60 BP + EBA 6808, H 6x70 BM, ESW 6x80, H 7xxx BP/BM/BMX, EBA 7868, ESW 7x80, Flush inset, NA

A – Cut-out (4" x 28" / 100 mm x 720 mm) in the bottom of the cabinet for power cord and ventilation. – Electrical and water supplies are recommended to be placed in adjacent cabinetry., Additional cabinet depth is required when placing the electrical and water supplies behind the appliance., E = Electric connection

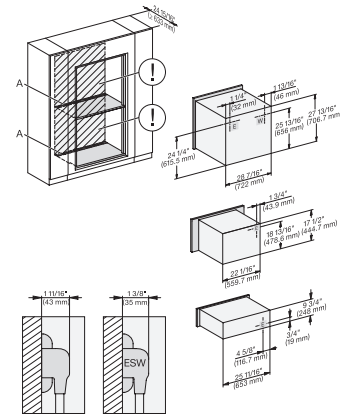

H 6x80 BP, H 6x70 BM, ESW 6x85, H 6x80-2BP, H 2880BP, H 7xxx BP/BPX/BM/BMX, Exx 7x70, Flush inset, NA

A – Cut-out (4" x 28" / 100 mm x 720 mm) in the bottom of the cabinet for power cord and ventilation. – Electrical and water supplies are recommended to be placed in adjacent cabinetry., Additional cabinet depth is required when placing the electrical and water supplies behind the appliance., E = Electric connection

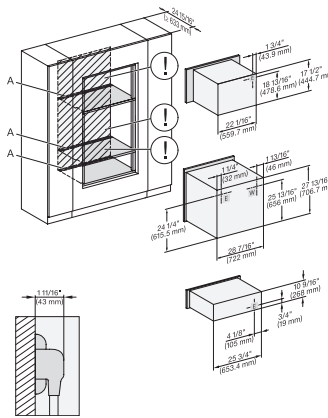

H 6x80 BP, H 6x70 BM, ESW 6x80, H 6x80-2BP, H 2x80BP, H 7xxx BP/BPX/BM/BMX, ESW 7x80, Flush inset, NA

A – Cut-out (4" x 28" / 100 mm x 720 mm) in the bottom of the cabinet for power cord and ventilation. – Electrical and water supplies are recommended to be placed in adjacent cabinetry., Additional cabinet depth is required when placing the electrical and water supplies behind the appliance., E = Electric connection

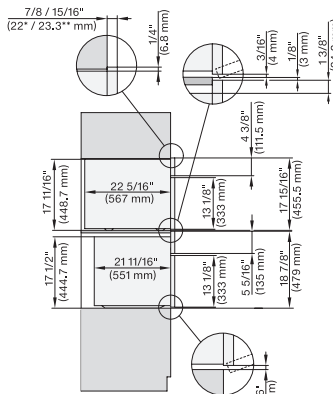

DGC 6x00-1 + EBA 6808, H 6x00 BM, DGC7x4x+EBA7848, H7x70BM(X), Combi, Installation drawing, Proud, NA

7/8" – 22" mm – Glas, 15/16" – 23.3" mm – Edelstahl

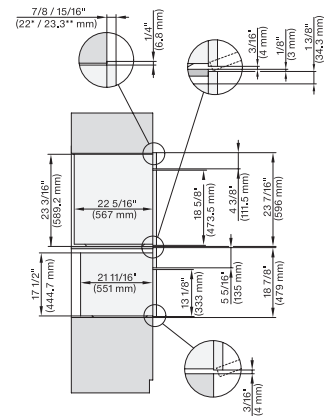

DGC 6x6x (AM) + EBA 6808, H 6x70 BM, DGC786x+EBA7868, H7x70BM(X), Combi, Installation drawing, Proud, NA

7/8" – 22" mm – Glas, 15/16" – 23.3" mm – Edelstahl

## H 7870 BMX

30" handleless compact speed oven

in a perfectly combinable design with automatic programs and roast probe.

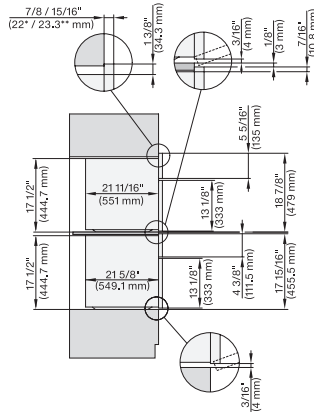

H 6x70 BM, H 6x00 BM + EBA 6808, H7x70BM+EBA7848, Combi, Installation drawing, Proud, NA

7/8" – 22\* mm – Glas, 15/16" – 23.3\*\* mm – Edelstahl

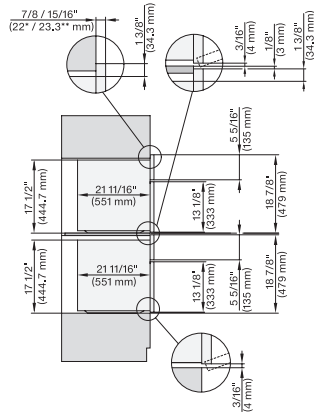

H 6x70 BM, H7x70BM(X), Combi, Installation drawing, Proud, NA

7/8" – 22\* mm – Glas, 15/16" – 23.3\*\* mm – Edelstahl

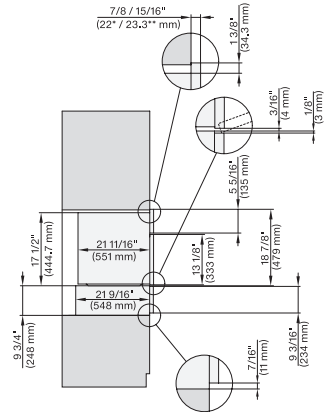

H 6x70 BM, ESW 6x85, H7x70BM(X), ESW7x70, EVS7670, Combi, Installation drawing, Proud, NA

7/8" – 22\* mm – Glas, 15/16" – 23.3\*\* mm – Edelstahl

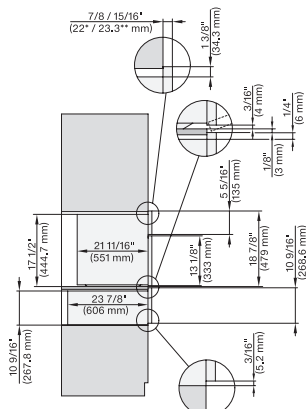

H 6x70 BM, ESW 6x80, H7x70BM(X), ESW7x80, Combi, Installation drawing, Proud, NA

7/8" – 22\* mm – Glas, 15/16" – 23.3\*\* mm – Edelstahl

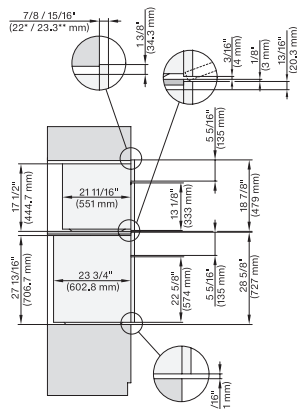

H 6x80 BP, H 6x70 BM, H 6x80-2BP, DGC7x7x, H7x70BM, H7x80BPX, Combi, Installation drawing, Proud, NA

7/8" – 22\* mm – Glas, 15/16" – 23.3\*\* mm – Edelstahl

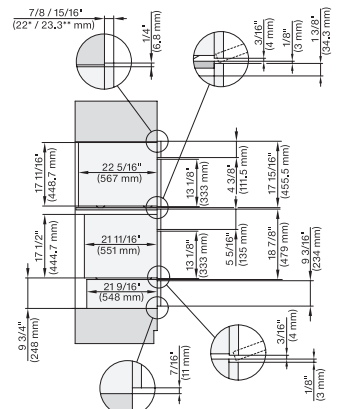

DGC6x00-1+EBA6808, H6x70BM, ESW6x85, DGC7x0+EBA7848, H7x70BM(X), ESW7x70, EVS7670, Combi, Installation drawing, Proud, NA

7/8" – 22\* mm – Glas, 15/16" – 23.3\*\* mm – Edelstahl

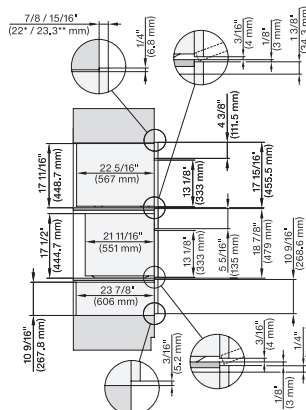

DGC 6x00-1 + EBA 6808, H 6x70 BM, ESW 6x80, DGC7x40+EBA7848, H7x70BM(X), ESW7x80, Combi, Installation drawing, Proud, NA

7/8" – 22\* mm – Glas, 15/16" – 23.3\*\* mm – Edelstahl

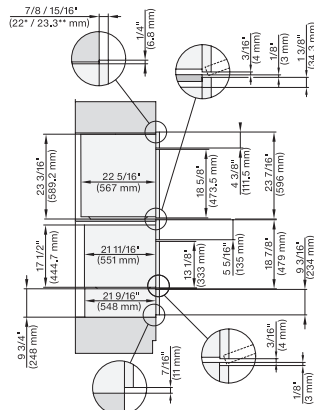

DGC6x6x+EBA6808, H6x70BM, ESW6x85, DGC786x+EBA7868, H7x70BM(X), ESW7x70, EVS7670, Combi, Installation drawing, Proud, NA

7/8" – 22\* mm – Glas, 15/16" – 23.3\*\* mm – Edelstahl

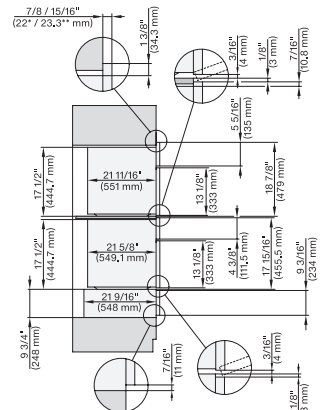

H6x70BM, H6x00BM+EBA6808, ESW6x85, DGC7x70, H7xx0BM(X)+EBA7848, ESW7x70, EVS7670, Combi, Installation drawing, Proud, NA

7/8" – 22\* mm – Glas, 15/16" – 23.3\*\* mm – Edelstahl

## H 7870 BMX

30" handleless compact speed oven

in a perfectly combinable design with automatic programs and roast probe.

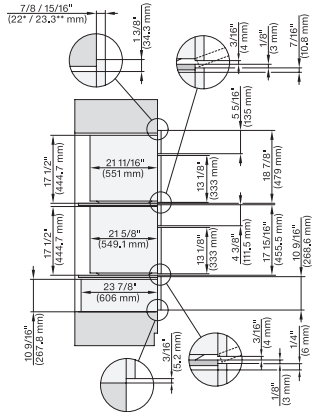

H6x70BM, H6x00BM+EBA6808, ESW6x80, DGC7x7x(X), H7xx0BM(X)+EBA7848, ESW7x80, Combi, Installation drawing, Proud, NA

7/8" – 22" mm – Glas, 15/16" – 23.3" mm – Edelstahl

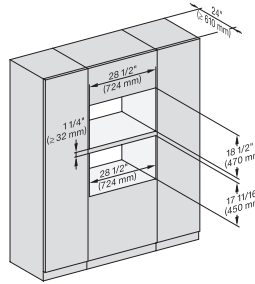

H6x70BM, (H6x00BM, DGC6x00-1) + EBA6808, H7x70BM(X), H7x40BM+EBA7848, Fitting Combi, Installation drawing, Proud, NA

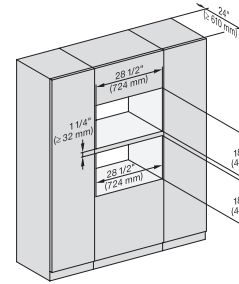

H 6x70 BM, H7x70BM(X), Fitting Combi, Installation drawing, Proud, NA

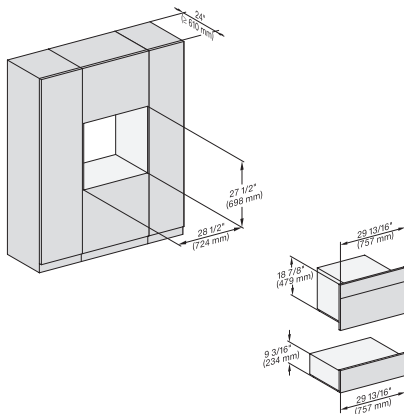

H6x70BM, ESW6x85, DGC7x7x, H7x70BMX, ESW7x70, EVS7x70, Fitting Combi, Installation drawing, Proud, NA

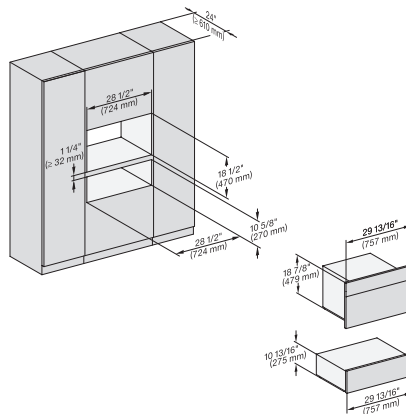

H 6x70 BM, ESW 6x80, DGC7x70X, H7x70BM, ESW7x80, Fitting Combi, Installation drawing, Proud, NA

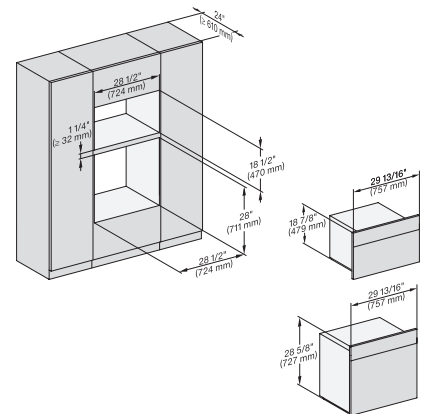

H6x80BP, H6x70BM, H6x80-2BP, DGC7x7x, H7x70BM, H2x80BP, H7x80BP(X), Fitting Combi, Installation drawing, Proud, NA

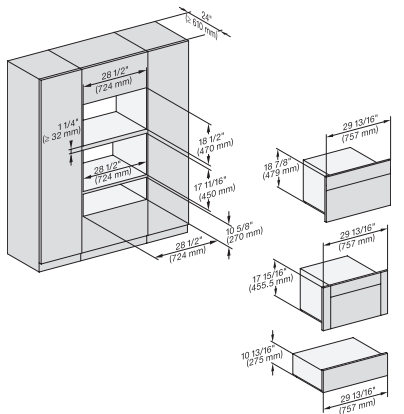

H6x70BM, (H6x00BM, DGC6x00-1)+EBA 6808, ESW6x80, H7x70BM, H7x40BM+EBA7848, ESW7x80, Fitting Combi, Installation, Proud,

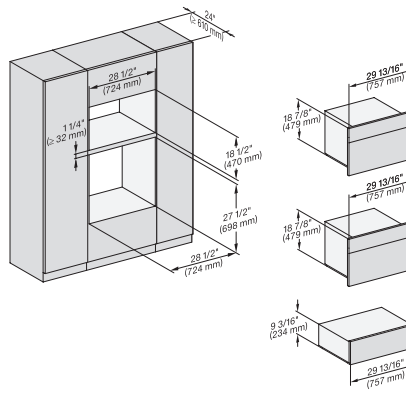

H6x70BM, ESW6x85, H7x70BM, ESW7x70, EVS7670, Fitting Combi, Installation drawing, Proud, NA

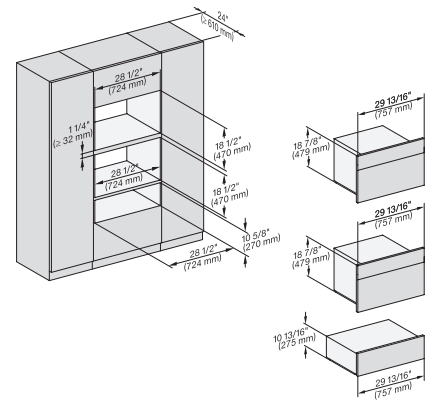

H 6x70 BM, ESW 6x80, H7x70BM, ESW7x80, Fitting Combi, Installation drawing, Proud, NA

## H 7870 BMX

30" handleless compact speed oven

in a perfectly combinable design with automatic programs and roast probe.

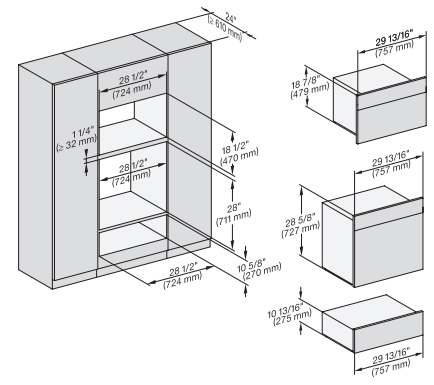
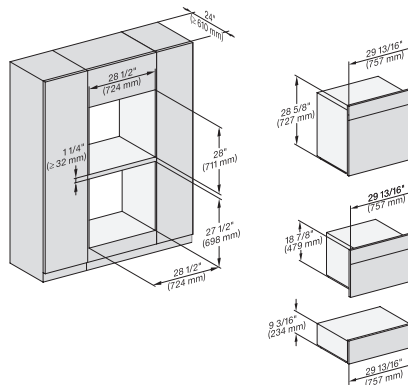
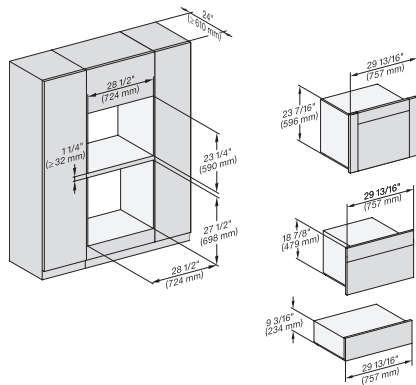

(H 6560 B, H 6x60 BP, DGC 686x AM) + EBA 6808; H 6x70 BM, ESW 6x85, NA7000, Fitting Combi, Installation drawing, Proud

H6x80BP, H6x70BM, ESW 6x85, H 6x80-2BP, NA7000, Fitting Combi, Installation drawing, Proud, NA

H 6x80 BP, H 6x70 BM, ESW 6x85, H 6x80-2BP, NA7000 Fitting Combi, Installation drawing, Proud, NA  
<https://miele-mms.de/miele.net/mms/admin/forward.php#>

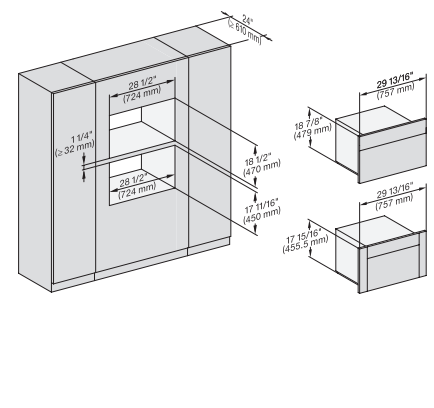
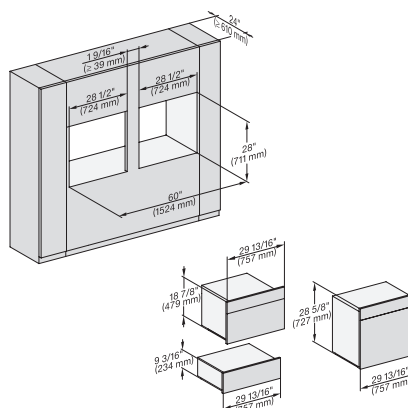
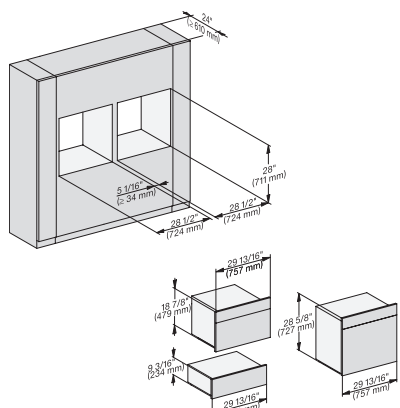

H 6x80 BP, H 6x70 BM, ESW 6x85, H 6x80-2BP, NA7000, Fitting Combi side by side, Installation drawing, Proud, NA

H6x80BP, H6x70BM, ESW6x85, H6x80-2BP, NA7000, Fitting Combi side by side without wall, Installation drawing, Proud, NA

H6x70BM, (H6x00BM, DGC6x00-1) + EBA6808, H7xxxBM(+EBA7848), Fitting Combi wide front, Installation drawing, Proud, NA

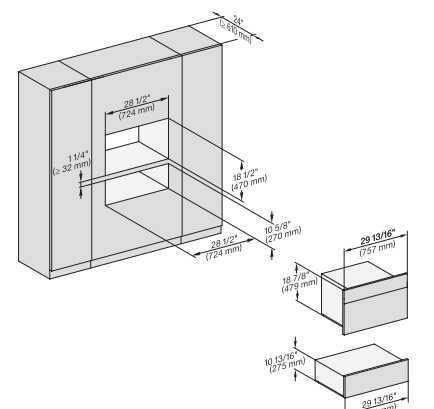
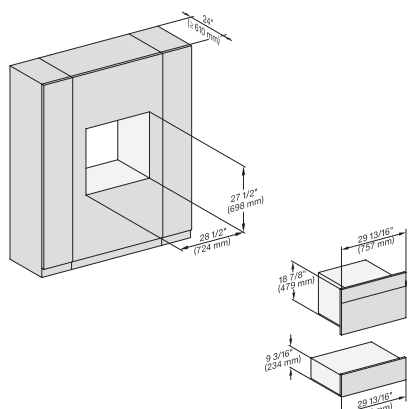
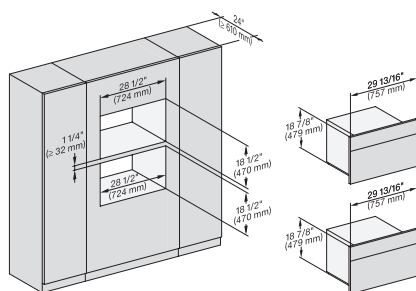

H 6x70 BM, H7x70BM(X) Fitting Combi wide front, Installation drawing, Proud, NA

H6x70BM, ESW6x85, DGC7x7x(X), H7x70BM(X), ESW7x70, EVS7670, Fitting Combi wide front, Installation drawing, Proud, NA

H6x70BM, ESW6x80, DGC7x7x(X), H7x70BM(X), ESW7x80, Fitting Combi wide front, Installation drawing, Proud, NA

## H 7870 BMX

30" handleless compact speed oven

in a perfectly combinable design with automatic programs and roast probe.

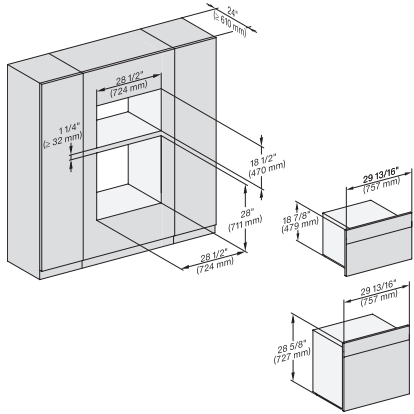

H6x80BP, H 6x70 BM, H 6x80-2BP, NA7000 Fitting Combi wide front, Installation drawing, Proud, NA

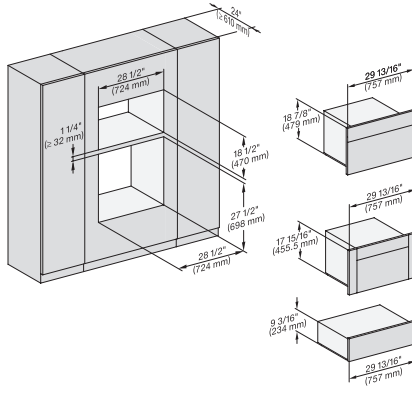

H6x70BM, H6x00BM + EBA6808, ESW6x85, DGC6x00-1 + EBA6808, NA7000 Fitting Combi wide front, Installation drawing, Proud

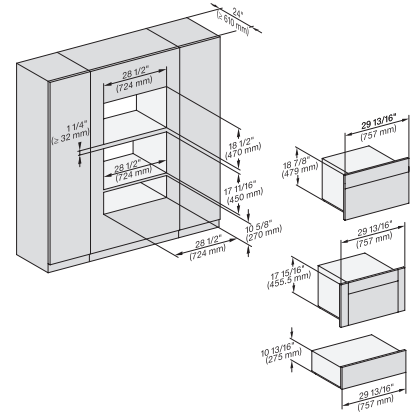

H6x70BM, H6x00BM + EBA6808, ESW6x80, DGC6x00-1 + EBA6808, NA7000 Fitting Combi wide front, Installation drawing, Proud

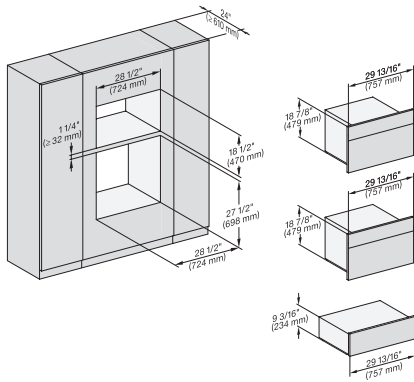

H 6x70 BM, ESW 6x85, NA7000, Fitting Combi wide front, Installation drawing, Proud, NA

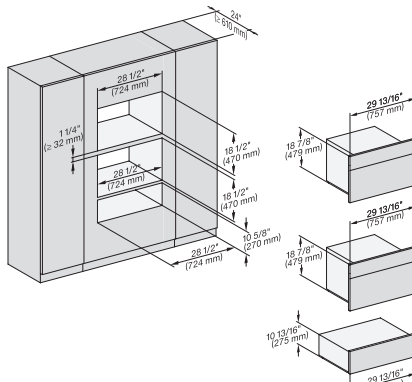

H 6x70 BM, ESW 6x80, H7x70BM(X), ESW7x80, Fitting Combi wide front, Installation drawing, Proud, NA

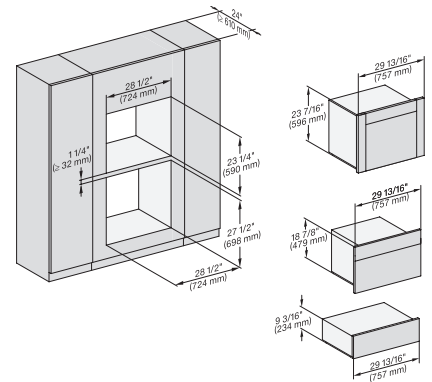

(H6560 B, H6x60 BP, H6x70 BM, DGC686x AM) + EBA6808; ESW6x85, DGC676x, NA7000, Fitting Combi w. front, drawing, Proud

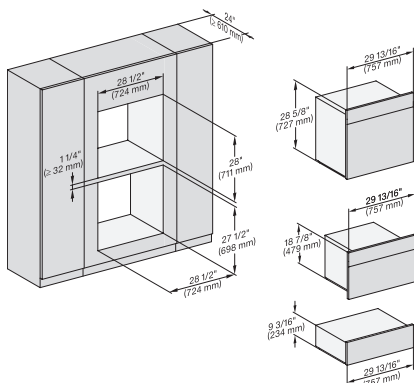

H 6x80 BP, H 6x70 BM, ESW 6x85, H 6x80-2BP, NA7000 Fitting Combi wide front, Installation drawing, Proud, NA

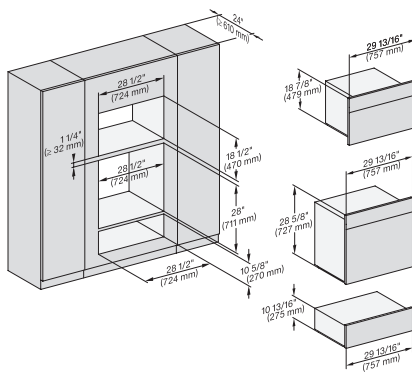

H 6x80 BP, H 6x70 BM, ESW 6x80, H 6x80-2BP, NA7000, Fitting Combi wide front, Installation drawing, Proud, NA

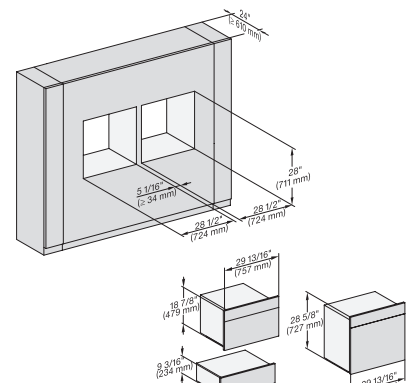

H 6x80 BP, H 6x70 BM, ESW 6x85, H 6x80-2BP, NA7000 Fitting Combi wide front side by side, Installation drawing, Proud

## H 7870 BMX

30" handleless compact speed oven

in a perfectly combinable design with automatic programs and roast probe.

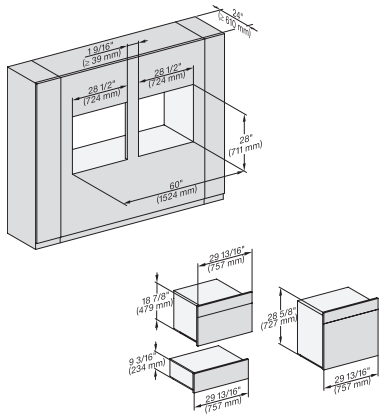

H 6x80 BP, H 6x70 BM, ESW 6x85, H 6x80-2BP, NA7000 Fitting Combi w. front side by side without wall, drawing, Proud, NA

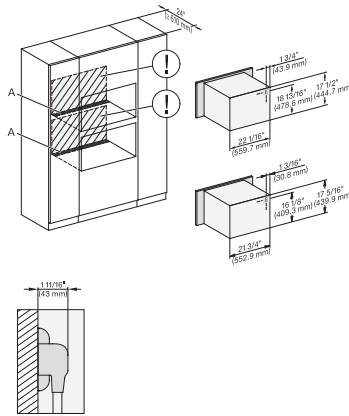

H 6x70 BM, H 6x00 BM + EBA 6808, H7x40BM(+EBA7848), Installation Combi, Installation drawing, Proud, NA

A – Cut-out (4" x 28" / 100 mm x 720 mm) in the bottom of the cabinet for power cord and ventilation, – Electrical and water supplies are recommended to be placed in adjacent cabinetry., Additional cabinet depth is required when placing the electrical and water supplies behind the appliance., E = Electric connection

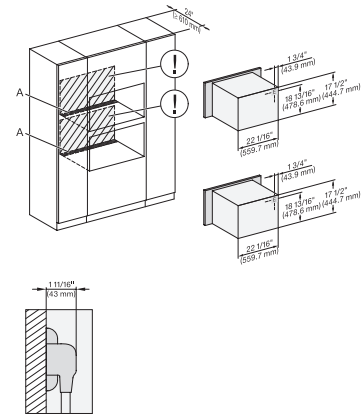

H 6x70 BM, H7x70BM(X), Installation Combi, Installation drawing, Proud, NA

A – Cut-out (4" x 28" / 100 mm x 720 mm) in the bottom of the cabinet for power cord and ventilation, – Electrical and water supplies are recommended to be placed in adjacent cabinetry., Additional cabinet depth is required when placing the electrical and water supplies behind the appliance., E = Electric connection

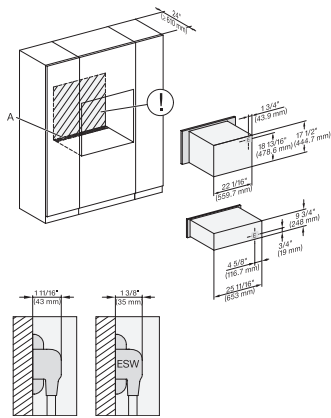

H 6x70 BM, ESW 6x85, H7x70BM(X), ESW7x70, EVS7670, Installation Combi, Installation drawing, Proud, NA

A – Cut-out (4" x 28" / 100 mm x 720 mm) in the bottom of the cabinet for power cord and ventilation, – Electrical and water supplies are recommended to be placed in adjacent cabinetry., Additional cabinet depth is required when placing the electrical and water supplies behind the appliance., E = Electric connection

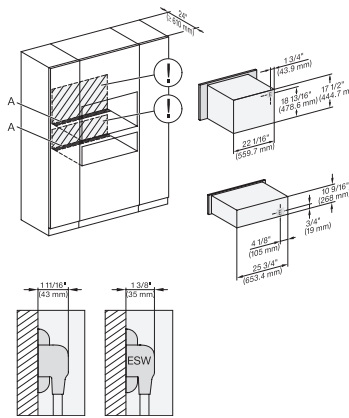

H 6x70 BM, ESW 6x80, H7x70BM(X), ESW7x80, Installation Combi, Installation drawing, Proud, NA

A – Cut-out (4" x 28" / 100 mm x 720 mm) in the bottom of the cabinet for power cord and ventilation, – Electrical and water supplies are recommended to be placed in adjacent cabinetry., Additional cabinet depth is required when placing the electrical and water supplies behind the appliance., E = Electric connection

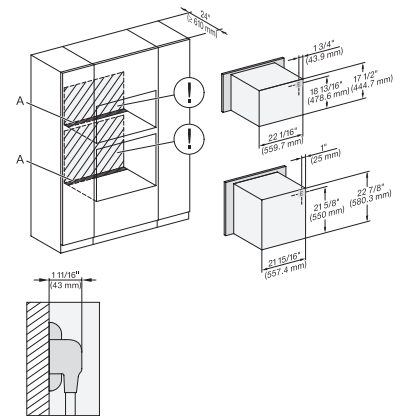

H6560B + EBA6808, H6x60BP + EBA6808, H6x70BM, H7x70BM, H7x6xBP+EBA7868, Installation Combi, Installation drawing, Proud,

A – Cut-out (4" x 28" / 100 mm x 720 mm) in the bottom of the cabinet for power cord and ventilation, – Electrical and water supplies are recommended to be placed in adjacent cabinetry., Additional cabinet depth is required when placing the electrical and water supplies behind the appliance., E = Electric connection

## H 7870 BMX

30" handleless compact speed oven

in a perfectly combinable design with automatic programs and roast probe.

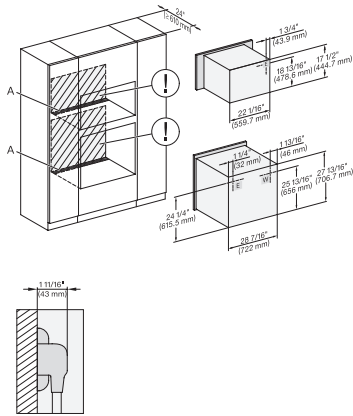

H 6x80 BP, H 6x70 BM, H 6x80-2BP, Hx70BM, H2x80BP(X), H7x80BP(X), Installation Combi, Installation drawing, Proud, NA

A – Cut-out (4" x 28" / 100 mm x 720 mm) in the bottom of the cabinet for power cord and ventilation. – Electrical and water supplies are recommended to be placed in adjacent cabinetry. Additional cabinet depth is required when placing the electrical and water supplies behind the appliance. E = Electric connection

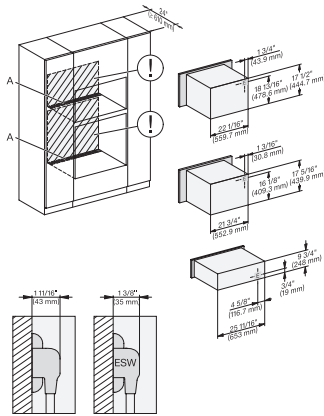

H6xx0BM+EBA6808, ESW6x85, H7xx0BM(+EBA7848), ESW7x70, EVS7x70, Installation Combi, Installation drawing, Proud, NA

A – Cut-out (4" x 28" / 100 mm x 720 mm) in the bottom of the cabinet for power cord and ventilation. – Electrical and water supplies are recommended to be placed in adjacent cabinetry. Additional cabinet depth is required when placing the electrical and water supplies behind the appliance. E = Electric connection

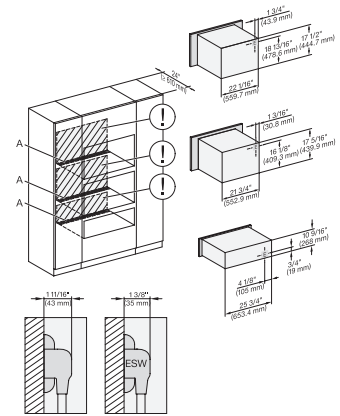

H 6x70 BM, H 6x00 BM + EBA 6808, ESW 6x80, H7xx0BM(+EBA7848) ESW7x80 Installation Combi, Installation drawing, Proud, NA

A – Cut-out (4" x 28" / 100 mm x 720 mm) in the bottom of the cabinet for power cord and ventilation. – Electrical and water supplies are recommended to be placed in adjacent cabinetry. Additional cabinet depth is required when placing the electrical and water supplies behind the appliance. E = Electric connection

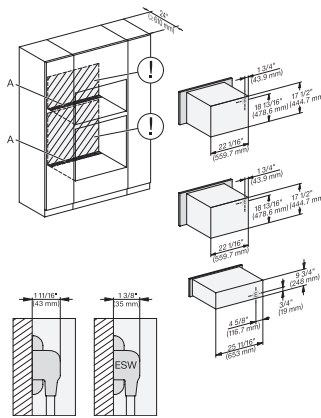

H 6x70 BM, ESW 6x85, H7x70BM, ESW7x70, EVS7670, Installation Combi, Installation drawing, Proud, NA

A – Cut-out (4" x 28" / 100 mm x 720 mm) in the bottom of the cabinet for power cord and ventilation. – Electrical and water supplies are recommended to be placed in adjacent cabinetry. Additional cabinet depth is required when placing the electrical and water supplies behind the appliance. E = Electric connection

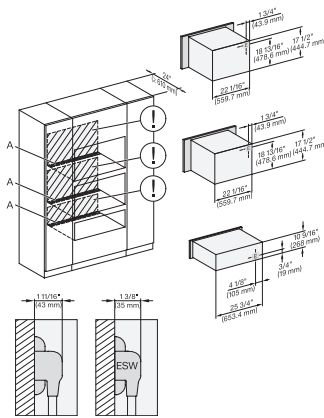

H 6x70 BM, ESW 6x80, H7x70BM, ESW7x80, Installation Combi, Installation drawing, Proud, NA

A – Cut-out (4" x 28" / 100 mm x 720 mm) in the bottom of the cabinet for power cord and ventilation. – Electrical and water supplies are recommended to be placed in adjacent cabinetry. Additional cabinet depth is required when placing the electrical and water supplies behind the appliance. E = Electric connection

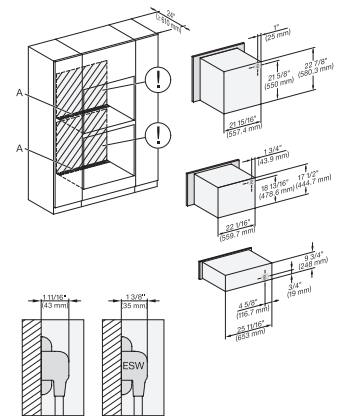

H 6560 B + EBA 6808, H 6x60 BP + EBA 6808, H 6x70BM, ESW6x85, NA7000 Installation Combi, Installation drawing, Proud, NA

A – Cut-out (4" x 28" / 100 mm x 720 mm) in the bottom of the cabinet for power cord and ventilation. – Electrical and water supplies are recommended to be placed in adjacent cabinetry. Additional cabinet depth is required when placing the electrical and water supplies behind the appliance. E = Electric connection

## H 7870 BMX

30" handleless compact speed oven

in a perfectly combinable design with automatic programs and roast probe.

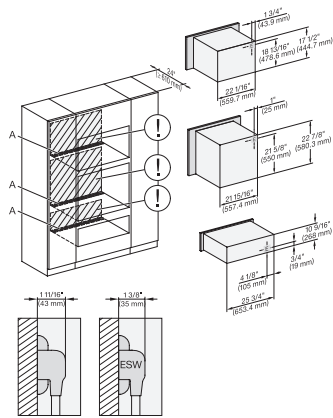

H 6560 B + EBA 6808, H 6x60 BP + EBA 6808, H6x70BM, ESW6x80, NA7000, Installation Combi, Installation drawing, Proud, NA

A – Cut-out (4" x 28" / 100 mm x 720 mm) in the bottom of the cabinet for power cord and ventilation. – Electrical and water supplies are recommended to be placed in adjacent cabinetry. Additional cabinet depth is required when placing the electrical and water supplies behind the appliance. E = Electric connection

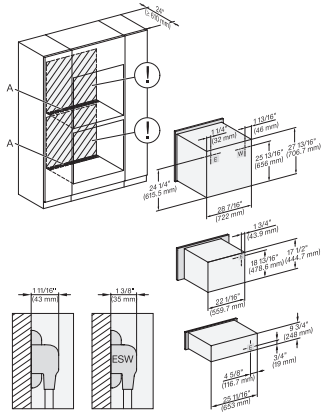

H 6x80 BP, H 6x70 BM, ESW 6x85, H 6x80-2BP, NA7000 Installation Combi, Installation drawing, Proud, NA

A – Cut-out (4" x 28" / 100 mm x 720 mm) in the bottom of the cabinet for power cord and ventilation. – Electrical and water supplies are recommended to be placed in adjacent cabinetry. Additional cabinet depth is required when placing the electrical and water supplies behind the appliance. E = Electric connection

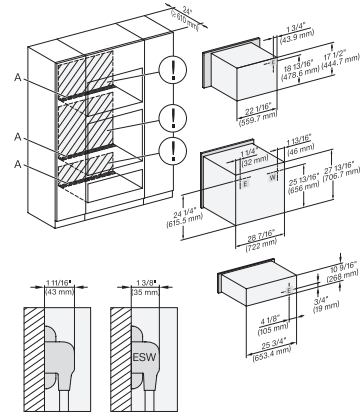

H 6x80 BP, H 6x70 BM, ESW 6x80, H 6x80-2BP, NA7000, Installation Combi, Installation drawing, Proud, NA

A – Cut-out (4" x 28" / 100 mm x 720 mm) in the bottom of the cabinet for power cord and ventilation. – Electrical and water supplies are recommended to be placed in adjacent cabinetry. Additional cabinet depth is required when placing the electrical and water supplies behind the appliance. E = Electric connection

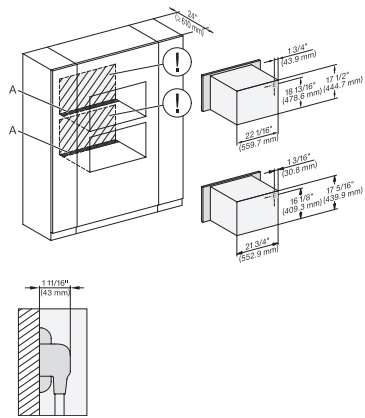

H6x70BM, H6x00BM + EBA 6808, H7x40BM+EBA7848, H7x70BM(X), Installation Combi wide front, Installation drawing, Proud, NA

A – Cut-out (4" x 28" / 100 mm x 720 mm) in the bottom of the cabinet for power cord and ventilation. – Electrical and water supplies are recommended to be placed in adjacent cabinetry. Additional cabinet depth is required when placing the electrical and water supplies behind the appliance. E = Electric connection

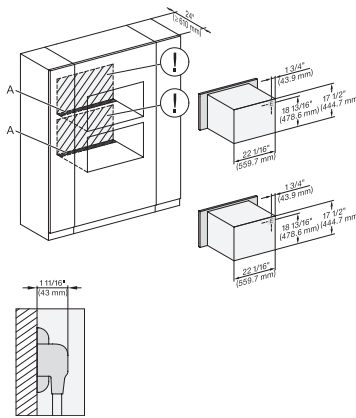

H 6x70 BM, H7x70BM(X), Installation Combi wide front, Installation drawing, Proud, NA

A – Cut-out (4" x 28" / 100 mm x 720 mm) in the bottom of the cabinet for power cord and ventilation. – Electrical and water supplies are recommended to be placed in adjacent cabinetry. Additional cabinet depth is required when placing the electrical and water supplies behind the appliance. E = Electric connection

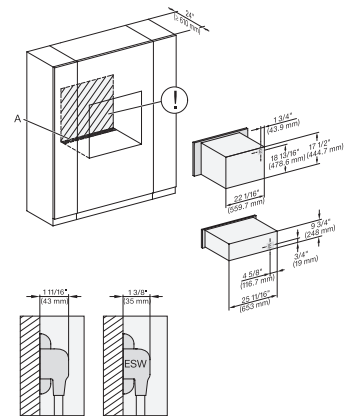

H 6x70 BM, ESW 6x85, H7x70BM(X), ESW7x70, EVS7670, Installation Combi wide front, Installation drawing, Proud, NA

A – Cut-out (4" x 28" / 100 mm x 720 mm) in the bottom of the cabinet for power cord and ventilation. – Electrical and water supplies are recommended to be placed in adjacent cabinetry. Additional cabinet depth is required when placing the electrical and water supplies behind the appliance. E = Electric connection

## H 7870 BMX

30" handleless compact speed oven

in a perfectly combinable design with automatic programs and roast probe.

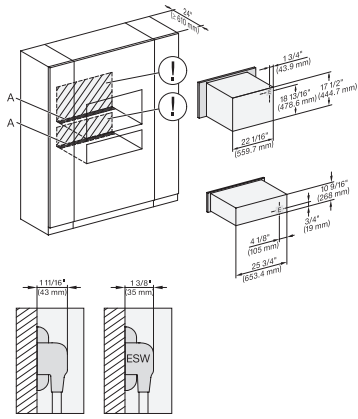

H 6x70 BM, ESW 6x80, H7x70BM, ESW7x80, Installation Combi wide front, Installation drawing, Proud, NA

A – Cut-out (4" x 28" / 100 mm x 720 mm) in the bottom of the cabinet for power cord and ventilation. – Electrical and water supplies are recommended to be placed in adjacent cabinetry. Additional cabinet depth is required when placing the electrical and water supplies behind the appliance. E = Electric connection

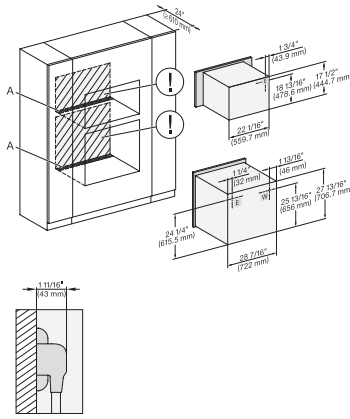

H 6x80 BP, H 6x70 BM, H 6x80-2BP, NA7000, Installation Combi wide front, Installation drawing, Proud, NA

A – Cut-out (4" x 28" / 100 mm x 720 mm) in the bottom of the cabinet for power cord and ventilation. – Electrical and water supplies are recommended to be placed in adjacent cabinetry. Additional cabinet depth is required when placing the electrical and water supplies behind the appliance. E = Electric connection

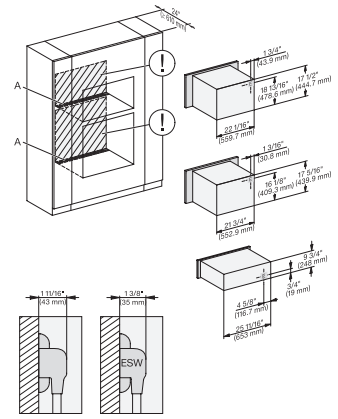

H 6x70 BM, H 6x00 BM + EBA 6808, ESW 6x85, NA7000, Installation Combi wide front, Installation drawing, Proud, NA

A – Cut-out (4" x 28" / 100 mm x 720 mm) in the bottom of the cabinet for power cord and ventilation. – Electrical and water supplies are recommended to be placed in adjacent cabinetry. Additional cabinet depth is required when placing the electrical and water supplies behind the appliance. E = Electric connection

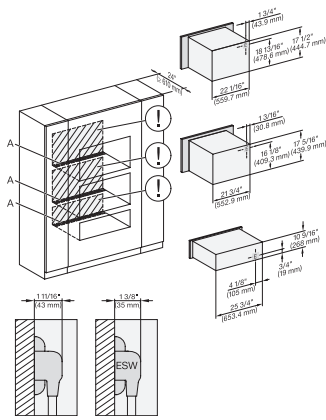

H 6x70 BM, H 6x00 BM + EBA 6808, ESW 6x80, NA7000, Installation Combi wide front, Installation drawing, Proud, NA

A – Cut-out (4" x 28" / 100 mm x 720 mm) in the bottom of the cabinet for power cord and ventilation. – Electrical and water supplies are recommended to be placed in adjacent cabinetry. Additional cabinet depth is required when placing the electrical and water supplies behind the appliance. E = Electric connection

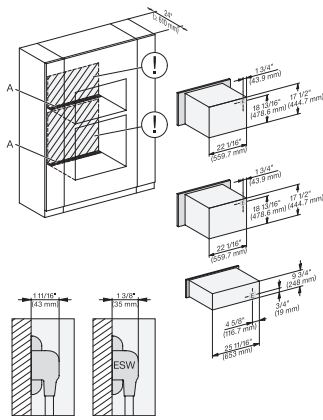

H 6x70 BM, ESW 6x85, H7x70BM, ESW7x70, EVS7670, Installation Combi wide front, Installation drawing, Proud, NA

A – Cut-out (4" x 28" / 100 mm x 720 mm) in the bottom of the cabinet for power cord and ventilation. – Electrical and water supplies are recommended to be placed in adjacent cabinetry. Additional cabinet depth is required when placing the electrical and water supplies behind the appliance. E = Electric connection

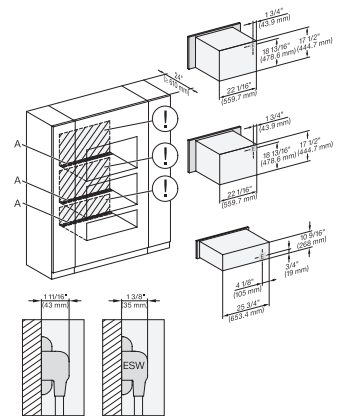

H 6x70 BM, ESW 6x80, H7x70BM, ESW7x80, Installation Combi wide front, Installation drawing, Proud, NA

A – Cut-out (4" x 28" / 100 mm x 720 mm) in the bottom of the cabinet for power cord and ventilation. – Electrical and water supplies are recommended to be placed in adjacent cabinetry. Additional cabinet depth is required when placing the electrical and water supplies behind the appliance. E = Electric connection

## H 7870 BMX

30" handleless compact speed oven

in a perfectly combinable design with automatic programs and roast probe.

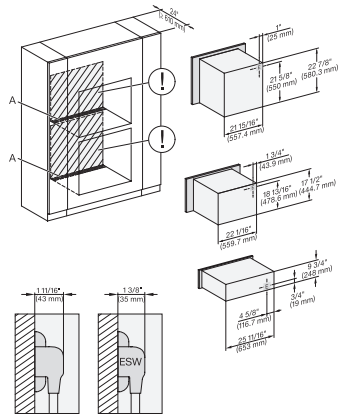

(H6560B, H6x60BP)+EBA6808, H6x70BM, ESW6x85, NA7000 Installation Combi wide front, Installation drawing, Proud, NA

A – Cut-out (4" x 28" / 100 mm x 720 mm) in the bottom of the cabinet for power cord and ventilation. – Electrical and water supplies are recommended to be placed in adjacent cabinetry., Additional cabinet depth is required when placing the electrical and water supplies behind the appliance., E = Electric connection

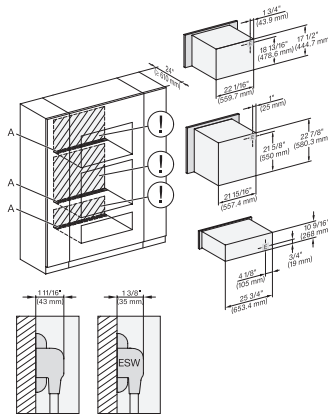

(H6560B, H6x60BP) + EBA6808, H6x70BM, ESW6x80, NA7000, Installation Combi wide front, Installation drawing, Proud, NA

A – Cut-out (4" x 28" / 100 mm x 720 mm) in the bottom of the cabinet for power cord and ventilation. – Electrical and water supplies are recommended to be placed in adjacent cabinetry., Additional cabinet depth is required when placing the electrical and water supplies behind the appliance., E = Electric connection

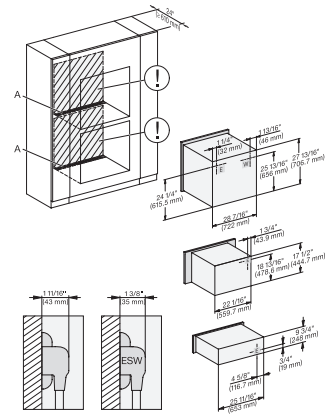

H 6x80 BP, H 6x70 BM, ESW 6x85, H 6x80-2BP, NA7000, Installation Combi wide front, Installation drawing, Proud, NA

A – Cut-out (4" x 28" / 100 mm x 720 mm) in the bottom of the cabinet for power cord and ventilation. – Electrical and water supplies are recommended to be placed in adjacent cabinetry., Additional cabinet depth is required when placing the electrical and water supplies behind the appliance., E = Electric connection

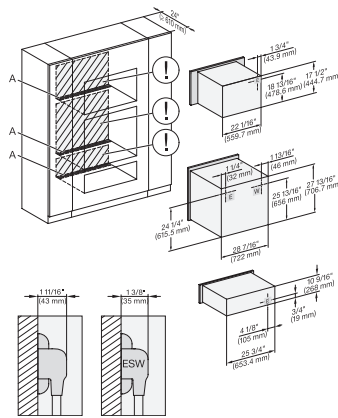

H 6x80 BP, H 6x70 BM, ESW 6x80, H 6x80-2BP, NA7000, Installation Combi wide front, Installation drawing, Proud, NA

A – Cut-out (4" x 28" / 100 mm x 720 mm) in the bottom of the cabinet for power cord and ventilation. – Electrical and water supplies are recommended to be placed in adjacent cabinetry., Additional cabinet depth is required when placing the electrical and water supplies behind the appliance., E = Electric connection



Triflex HX1, Graphite grey, SEB430, carpet, standard lamp, armchair