

SUBMITTAL DATA

MULTI24HP230V1EO
24000 BTU/H Multi-Zone Heat Pump System

Job Name

Location

Date

Purchaser

Engineer

Submitted to

For

Unit Designation

Schedule No.



MULTI24HP230V1EO

GENERAL FEATURES

- AHRI Certificate: 210278975 (Non-Ducted)
210278976 (Ducted)
210278984 (Mixed)
- High Efficiency DC Inverter Technology
- Compact and Quiet Design
- Auto Restart on Power Outages
- Multi-point Diagnostics
- Wi-Fi Included (Factory Installed)
- Low Ambient Cooling down to -20°F (Range -22°F to 118°F)
- Low Ambient Heating down to -22°F (Range -22°F to 75°F)
- Coil (Indoor and Outdoor) Copper Tube / Aluminum Fin
- Blue Colored Fin - 500 Hrs Salt Spray Tested

SPECIFICATIONS, FEATURES & FUNCTION SUMMARY

SPECIFICATIONS		MULTI24HP230V1EO	
System Type	HEAT PUMP		
Number of Zones	2 - 3		
SYSTEM PERFORMANCE		NON-DUCTED INDOOR UNITS	
Cooling	Min - Max	Btu/h	7500 - 31400
	Capacity @95°F	Btu/h	23200
Heating	Min - Max	Btu/h	7500 - 31400
	Capacity @5°F	Btu/h	21600
	Capacity @17°F	Btu/h	23600
	Capacity @47°F	W	24000
SEER2	21		
EER2	12.5		
HSPF2	10		
COP @5°F	2.1		
COP @47°F	3.9		
SYSTEM PERFORMANCE		DUCTED INDOOR UNITS	
Cooling	Min - Max	Btu/h	7500 - 31400
	Capacity @95°F	Btu/h	23200
Heating	Min - Max	Btu/h	7500 - 31400
	Capacity @5°F	Btu/h	23000
	Capacity @17°F	Btu/h	23000
	Capacity @47°F	W	24000
SEER2	16		
EER2	11		
HSPF2	8		
COP @5°F			
COP @47°F	3.4		
SYSTEM PERFORMANCE		MIXED DUCTED AND NON-DUCTED INDOOR UNITS	
Cooling	Min - Max	Btu/h	7500 - 31400
	Capacity @95°F	Btu/h	23200
Heating	Min - Max	Btu/h	7500 - 31400
	Capacity @5°F	Btu/h	
	Capacity @17°F	Btu/h	
	Capacity @47°F	W	24000
SEER2	18.5		
EER2	11.8		
HSPF2	9		
COP @5°F			
COP @47°F	3.7		
OUTDOOR UNIT		MULTI24HP230V1EO	
Cooling Temperature Range	°F	-22 - 118	
Heating Temperature Range	°F	-22 - 75	
Refrigerant Type	R410A		
Compressor Type	GREE G-10 / 2 - STAGE INVERTER		
Sound Pressure Level	dB(A)	58	
External Dimensions (W x H x D)	in	38 x 26 x 15-7/8	
Package Dimension (W x H x D)	in	40-5/8 x 29 x 18	
Net Weight	lbs	114.6	
Gross Weight	lbs	124.6	

REFRIGERANT PIPING		
Refrigerant Charge - R410A	oz	84.6
Additional Charge	oz/ft	0.2
Port Size (Liquid - Gas)	port A (in)	1/4 - 3/8
	port B (in)	1/4 - 3/8
	port C (in)	1/4 - 3/8
	port D (in)	
	port E (in)	
Pre-Charge Length	ft	98
Pipe Length (Min - Max)	ft	10 - 197
Pipe Length to furthest Indoor Unit	ft	66
Max. Pipe Elevation	ft	49
ELECTRICAL		
Power Supply	208-230V / 1Ph / 60Hz	
Voltage Range (Min - Max)	VAC	187 - 253
Rated Current - Cooling	A	15
Rated Current - Heating	A	15
MCA	A	19
MOCP	A	25
Suggested Breaker Size	A	20
Main Power Wire Size	AWG	Per Local Code
Interconnecting Wire Size	AWG	14 / 4

FEATURES & FUNCTIONS SUMMARY	MULTI24HP230V1EO
SYSTEM FEATURES	
Inverter Type	G10
Ultra Low Frequency Torque Control	Yes
Power Factor Correction	Yes
Compressor Type - Inverter	High Efficiency Rotary
Basepan With Electric Heater	Yes
Indoor & Outdoor Fin Coating (Blue Fin)	Yes
Intelligent Defrosting	Yes
Intelligent Preheating	Yes
Low Voltage Startup	Yes
Memory/Power Failure Recovery	Yes
Self Diagnosis	Yes

DIMENSIONS

OUTDOOR UNIT

Unit: inch

MULTI24HP230V1EO

DIMENSIONS

A	35
B	38
C	26
D	13-25/64
E	15-7/8
F	22-7/16
G	14-39/64

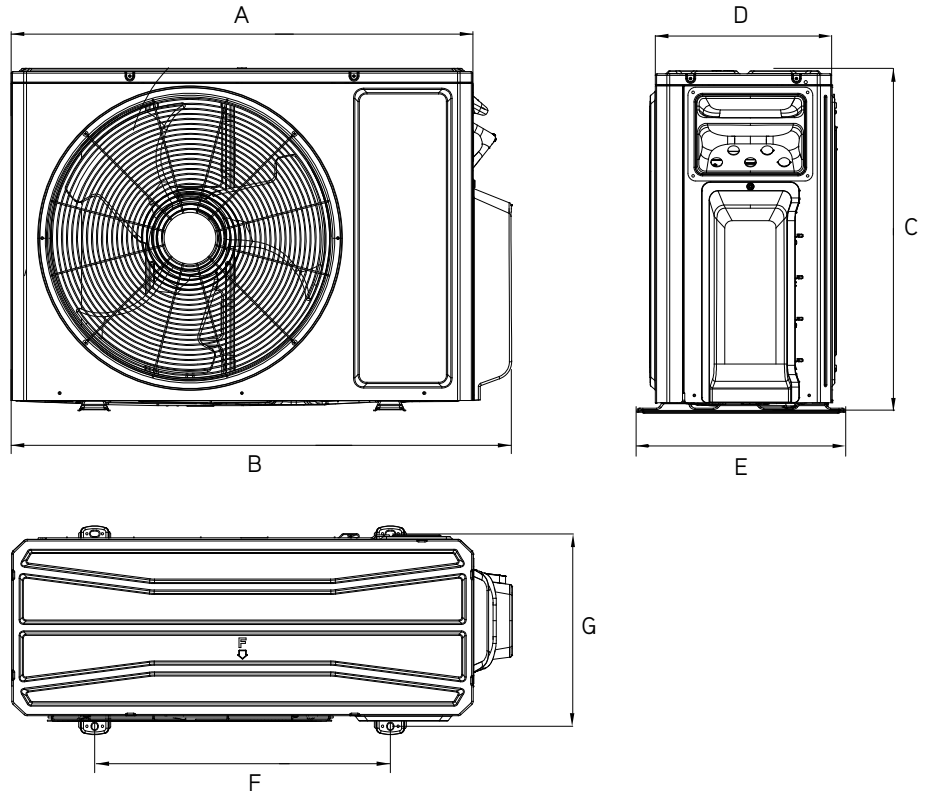

CLEARANCES

OUTDOOR UNIT

Minimum clearance

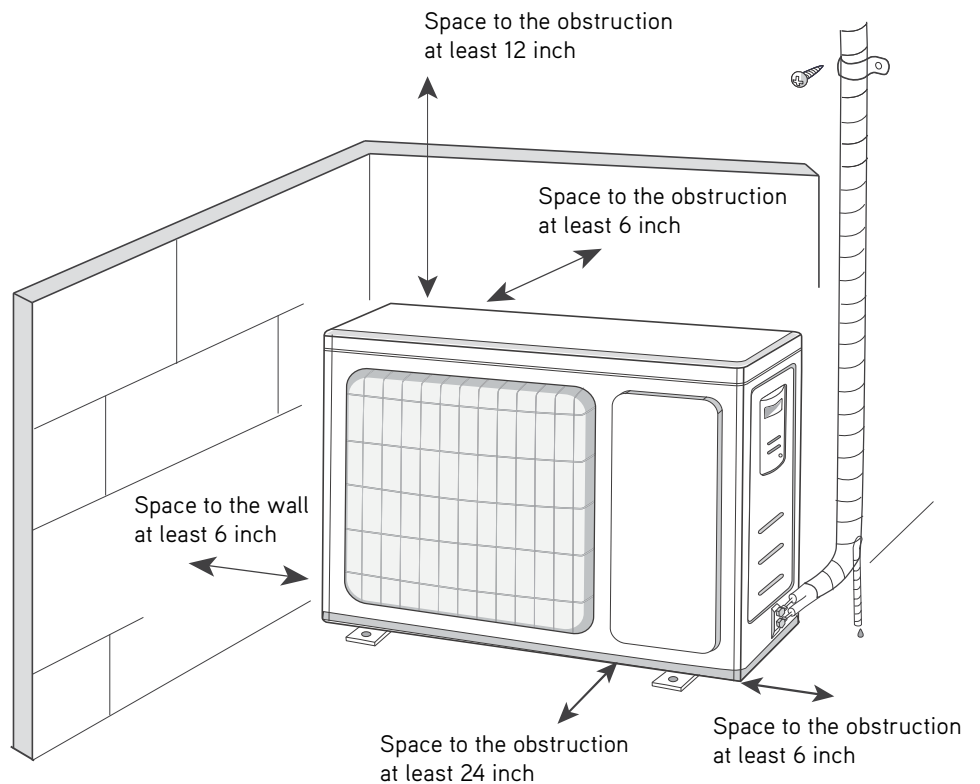
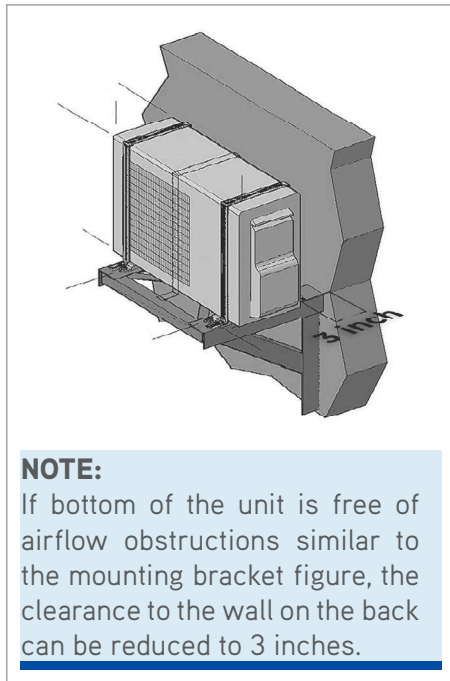

Specifications are subject to change without notice. Manufacturer reserves the right to discontinue or modify specifications or designs without notice or without incurring obligations. All Rights reserved.

GREECOMFORT.COM/SYSTEM-DOCUMENTATION