

GTJ17DBE

GE® ENERGY STAR® 16.5 Cu. Ft. Top-Freezer Refrigerator

Dimensions and Installation Information (in inches)

Overall Dimensions	Height to top of hinge (in.) A	64-3/4
	Height to top of case (in.) B	64-1/4
	Case depth without door (in.) C	25-7/8
	Case depth less door handle (in.) D	29-1/8
	Case depth with door handle (in.) E	31
	Depth with fresh food door open 90° (in.) F	54-7/8
	Width (in.) G	28
	Width with door open 90° with door handle (in.) H	30-1/2
Air Clearances	Each side (in.)	3/4
	Top (in.)	1
	Back (in.)	2

Front View

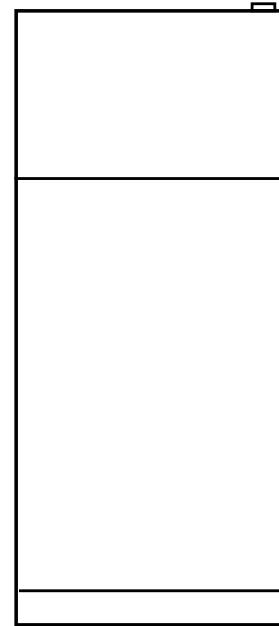

Top View

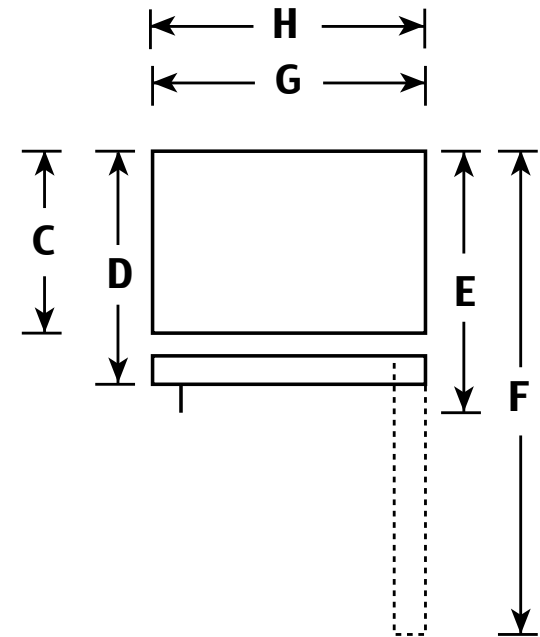

For answers to your Monogram®, Cafe™ Series, Profile™ Series or GE® appliance questions, visit our website at geappliances.com or call GE Answer Center® service, 800.626.2000.



imagination at work



Listed by Underwriters Laboratories



Total volume and shelf area are calculated by the Association of Home Appliance Manufacturers' standards.



As an ENERGY STAR® partner, GE has determined that this product meets the ENERGY STAR guidelines for energy efficiency.

GTJ17DBE

GE® ENERGY STAR® 16.5 Cu. Ft. Top-Freezer Refrigerator

Features and Benefits

- Silver metallic exterior - Attractive finish holds magnets and resists fingerprints
- Adjustable wire shelves - Moveable racks can handle a variety of foods
- Upfront temperature controls - Easy-to-use controls regulate both fresh food and freezer sections
- Gallon door storage - Larger items are easily accommodated in the door
- Clear crisper drawers - Transparent drawers make finding your favorite items quick and easy
- Wire freezer shelf - Provides additional storage for frozen foods
- Never Clean condenser - Sealed compartment keeps coils clean and simplifies maintenance
- Model GTJ17DBESA - Silver metallic

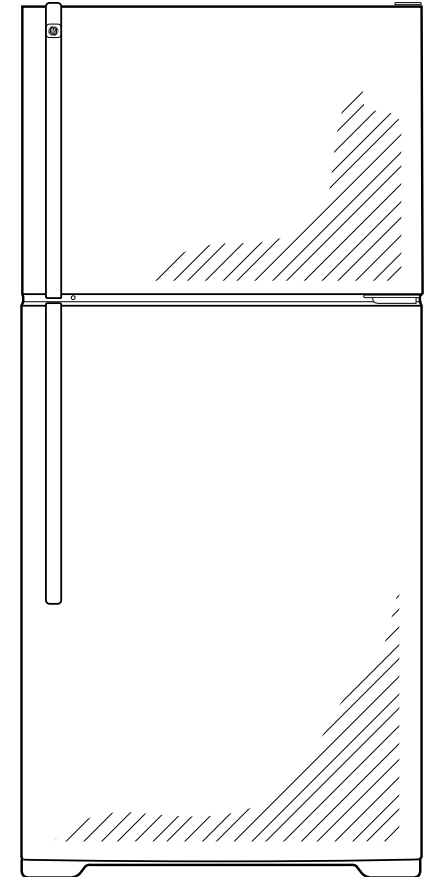

imagination at work



As an ENERGY STAR® partner, GE has determined that this product meets the ENERGY STAR guidelines for energy efficiency.

Specification Created 2/13

310406