

This gas patio flame must be used only outdoors in a well-ventilated space and must not be used inside a building, garage, screened-in porch, gazebo or any other enclosed area.

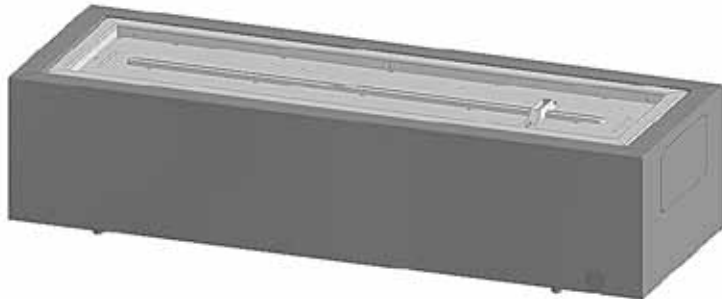

LINEAR PATIOFLAME OUTDOOR GAS FIREPLACE

*GPFL48 (WITHOUT ENCLOSURE)
GPFL48MHP (WITH ENCLOSURE)*

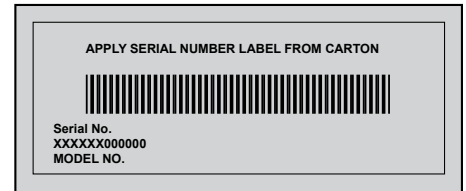

DANGER! CARBON MONOXIDE HAZARD

This appliance can produce carbon monoxide, which has no odor. Using it in an enclosed space can kill you. Never use this appliance in an enclosed space such as a camper, tent, car or home.



DANGER

IF YOU SMELL GAS:

- Shut off gas to the appliance.
- Extinguish any open flame.
- If odor continues, keep away from the appliance and immediately call your gas supplier or fire department.



WARNING! For Outdoor Use Only.



WARNING

Do not try to light this appliance without reading the "LIGHTING" instructions section of this manual.

Do not store or use gasoline or other flammable liquids or vapors in the vicinity of this or any other appliance. An L.P. cylinder not connected for use must not be stored in the vicinity of this or any other appliance. If the information in these instructions is not followed exactly, a fire or explosion may result, causing property damage, personal injury or death.

INSTALLER: LEAVE THIS MANUAL WITH THE APPLIANCE.

CONSUMER: RETAIN THIS MANUAL FOR FUTURE REFERENCE.



Napoleon Appliance Corp.,
214 Bayview Dr., Barrie, Ontario, Canada L4N 4Y8 Phone: (705)726-4278
Fax: (705)725-2564 email: wecare@napoleonproducts.com web site: www.napoleongrills.com



NAPOLEON products are designed with superior components and materials, and are assembled by trained craftsmen who take great pride in their work. Every component has been thoroughly inspected by a qualified technician before packaging and shipping to ensure that you, the customer, receive the quality product you expect from NAPOLEON.

Napoleon® Gas Appliance 5 Year Limited Warranty

All stainless steel components (excluding burner screen) of your new NAPOLEON® gas appliance are warranted against defects for five years.

Components such as gas valves, thermocouples, igniters, logs, glass embers and gaskets are covered and NAPOLEON® will provide replacement parts free of charge during the first year of limited warranty.

NAPOLEON shall not be liable for any transportation charges, labor costs or export duties.

Conditions And Limitations

NAPOLEON® warrants its products against manufacturing defects to the original purchaser only. Registering your warranty is not necessary. Simply provide your proof of purchase along with the model and serial number to make a warranty claim. NAPOLEON® reserves the right to have its representative inspect any product or part thereof prior to honouring any warranty claim. Provided that the purchase was made through an authorized NAPOLEON® dealer your heater is subject to the following conditions and limitations:

This limited warranty applies only while the unit remains at the site of original installation, and only if the unit is installed in Canada or the United States.

This factory warranty is non-transferable and may not be extended whatsoever by any of our representatives.

Installation must be done in accordance with the installation instructions included with the product and all local and national building and fire codes.

This limited warranty does not cover damages caused by misuse; lack of maintenance, accident, alterations, abuse or neglect and parts installed from other manufacturers will nullify this warranty.

This limited warranty further does not cover any scratches, dents, corrosion or discoloring caused by excessive heat, abrasive and chemical cleaners, mechanical breakage of logs and embers.

In the first year only, this warranty extends to the repair or replacement of warranted parts which are defective in material or workmanship provided that the product has been operated in accordance with the operation instructions and under normal conditions.

After the first year, with respect to the President's Limited Lifetime Warranty, NAPOLEON® may, at its discretion, fully discharge all obligations with respect to this warranty by refunding to the original warranted purchaser the wholesale price of any warranted but defective parts).

After the first year, NAPOLEON® will not be responsible for installation, labour or any other costs or expenses related to the reinstallation of a warranted part, and such expenses are not covered by this warranty.

Notwithstanding any provisions contained in the President's Limited Lifetime Warranty, napoleon's responsibility under this warranty is defined as above and it shall not in any event extend to any incidental, consequential or indirect damages.

This warranty defines the obligations and liability of NAPOLEON® with respect to the NAPOLEON® gas appliance and any other warranties expressed or implied with respect to this product, its components or accessories are excluded.

This limited warranty does not cover damages resulting from the use of components not supplied with the appliance, or the use of fuel other than those specified.

Any damages to appliance due to weather, long periods of dampness, condensation, damaging chemicals or cleaners will not be the responsibility of NAPOLEON®.

The bill of sale or copy will be required together with a serial number and a model number when making any warranty claims from your authorized dealer. The warranty registration card must be returned within fourteen days to register the warranty.

NAPOLEON® reserves the right to have its representative inspect any product or part thereof prior to honouring any warranty claim.



WARNING! For Outdoor Use Only.



WARNING! Improper installation, adjustment, alteration, service or maintenance can cause injury or property damage. Read the installation, operating and maintenance instructions thoroughly before installing or servicing this gas patio flame.



Safe Operating Practices

- **THIS APPLIANCE IS HOT WHEN OPERATING AND CAN CAUSE SEVERE BURNS IF CONTACTED.**
- **Installation and repair should be done by a qualified service person. The appliance should be inspected before use and at least annually by a qualified service person. More frequent cleaning may be required as necessary. It is imperative the control compartment, burners and circulating air passageways of the appliance be kept clean.**
- Do not operate appliance before reading and understanding operating instructions. Failure to operate appliance according to operating instructions could cause fire or injury.
- Risk of burns. The appliance should be turned off and cooled before servicing.
- Do not install damaged, incomplete or substitute components.
- **Young children should be carefully supervised when they are in the vicinity of the appliance. Toddlers, young children and others may be susceptible to accidental contact burns. A physical barrier is recommended if there are at risk individuals in the house. To restrict access to an appliance or stove, install an adjustable safety gate to keep toddlers, young children and other at risk individuals out of the vicinity and away from hot surfaces.**
- Ensure you have incorporated adequate safety measures to protect infants/toddlers from touching hot surfaces.
- Under no circumstances should this appliance be modified.
- Keep the packaging material out of reach of children and dispose of the material in a safe manner. As with all plastic bags, these are not toys and should be kept away from children and infants.
- Do not leave appliance unattended when in use.
- For Outdoor use only.
- This appliance must not be used for cooking.
- This unit is not for use with solid fuel.
- Improper installation, adjustment, alteration, service, or maintenance can cause injury or property damage. Read the installation, operating and maintenance instructions thoroughly before installing or servicing this equipment.
- This appliance shall be used **ONLY** outdoors in a well-ventilated space and shall **NOT** be used inside a building, garage, or any other enclosed area.
- Cylinders must be stored outdoors in a well-ventilated area out of reach of children. Disconnected cylinders must have threaded valve plugs tightly installed and must not be stored in a building, garage or any other enclosed area.
- Storage of this appliance indoors is permissible only if it has been disconnected from its fuel supply (natural gas line or LP gas cylinder).
- If it is evident there is excessive abrasion or wear, or the hose is cut, it must be replaced prior to the appliance being put into operation.
- **Clothing or other flammable materials should not be hung from the appliance, or placed on or near the appliance.**
- **Any guard or other protective device removed for servicing the appliance must be replaced prior to operating the appliance.**
- Inspect the fuel supply connection for signs of leakage (including the hose for LP models) before each use of the appliance.
- The pressure regulator and hose assembly supplied with LP models must be used. Replacement pressure regulators and hose assemblies must be those specified in this manual.
- The LP gas supply cylinder used with LP models must be constructed and marked in accordance with the specifications for LP-gas cylinders as required by the U.S. Department of Transportation (DOT) or the Canadian Transport Commission (CTC).
- The LP gas cylinder supply system must be arranged for vapour withdrawal.
- The LP-gas cylinder used must include a collar to protect the cylinder valve.
- When an LP model is not in use, the LP-gas must be turned off at the supply cylinder.
- To extend the life of your appliance, protect and cover it from the elements when not in use.
- This product must be installed by a licensed plumber or gas fitter when installed within the commonwealth of Massachusetts.

General Information

This gas appliance is certified under Canadian and American National Standards, ANSI Z21.97-2010 “Standard for Outdoor Decorative Gas Appliance” and CAN/CGA 2.17-M91 (R2009) “Gas-Fired Appliance for use at High Altitude” and should be installed to conform with local codes. In absence of local codes, install to the current CAN/CSA-B149.1 Propane Installation Code in Canada or to the National Fuel Gas Code, ANSI Z223.1 in the United States.

This appliance should be installed and serviced by a qualified installer to conform with local codes.

Installation practices vary from region to region and it is important to know the specifics that apply to your area, for example: in Massachusetts State:

- The appliance off valve must be a “T” handle gas cock.
- The flexible connector must not be longer than 36 inches.

The installation must conform with local codes or in the absence of local codes, with the National Fuel Gas Code ANSI Z223.1/INFPA 54 in the United States or CSA B149.1, Natural and Propane Installation code in Canada.

The appliance and its individual shut off valve must be disconnected from the gas supply piping system during any pressure testing of the system at test pressures in excess of 1/2 psig (3.5kPa).

This appliance must be isolated from the gas supply piping system by closing its individual manual shut off valve during any pressure testing of the gas supply piping system at test pressures equal to or less than 1/2 psig (3.5kPa).

The following clearances to combustible materials must be maintained:

Sides (all around)	- 24 inches (610mm)
Top	- 72 inches (1830mm)

- Always keep the appliance area clear and free from combustible materials, gasoline, and other flammable vapours and liquids.
- Do not locate appliance where it can get excessively wet.
- Do not use this appliance if any part has been under water. Immediately call a qualified service technician to inspect the unit and to replace any part of the control system and any gas control, which has been underwater.



We suggest that our gas hearth products be installed and serviced by professionals who are certified in the U.S. by the National Fireplace Institute® (NFI) as NFI Gas Specialists.

Getting Started

1. Remove all of the parts from the carton. Use the parts list to ensure all necessary parts are included.
2. Do not destroy packaging until the patio flame has been installed and operates to your satisfaction.
3. Choose a location that meets the clearance to combustibles as outlined in the specification section of this manual. Take into consideration the need for clear and easy access to the on/off valve AFTER the appliance is installed and connected to the gas supply in order to safely turn off the burner.
4. Most stainless steel parts are supplied with a protective plastic coating that must be removed prior to using the patio flame.
5. Read and follow all instructions in this manual before installing or servicing this gas patio flame.

If you have any questions about assembly or patio flame operation, or if there are damaged or missing parts please call our Customer Care Department at 1-866-820-8686 between 9 AM and 5 PM (Eastern Standard Time).



WARNING! This appliance is designed for non-combustible enclosures only, and must be installed and serviced by a qualified installer to local codes.

Specifications

DIMENSIONS

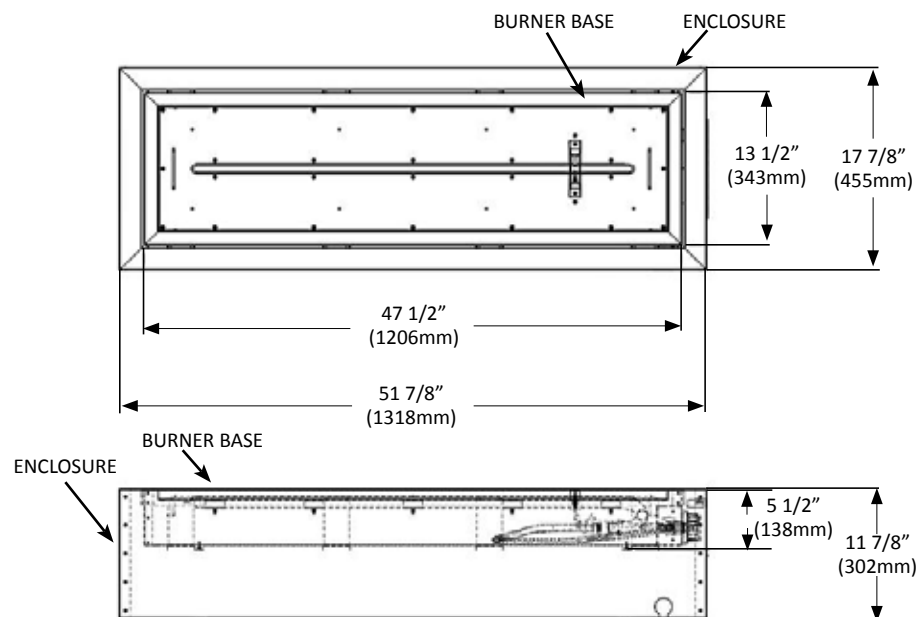

INPUT		
MODEL	FUEL	MAX. INPUT Btu/Hr
GPFL48N	Natural Gas	60,000
GPFL48P	Propane Gas	60,000

GAS INLET PRESSURES		
	NATURAL	PROPANE
Inlet Pressure	7.0" w.c.	11.0" w.c.

MINIMUM CLEARANCE TO COMBUSTIBLES		
	INCHES	MM
Side Walls	24	610
Top of unit to ceiling	72	1830

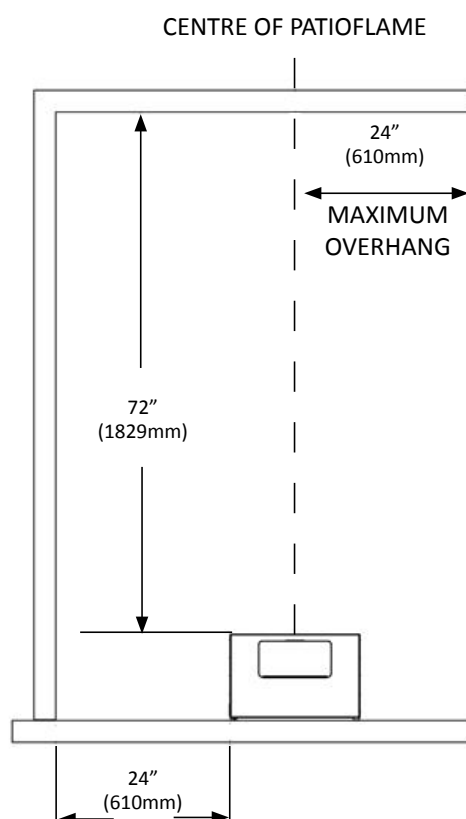

Installation Options

This unit is designed with some unique features that allow for maximum installation flexibility.

1. The gas supply to the enclosure can come either from underneath or through the side of the enclosure.

The gas supply is shown entering the side of the enclosure.

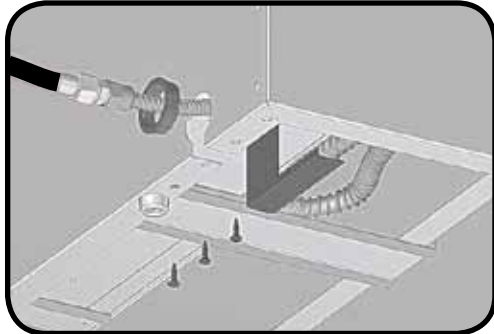

Ensure bushing snaps into side panel as shown.

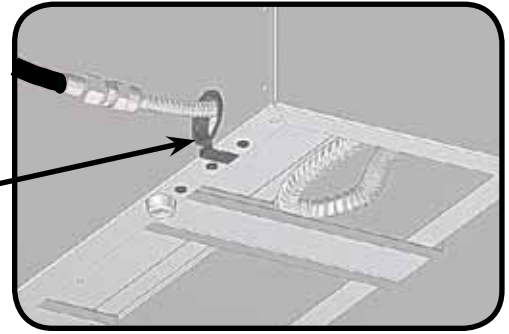

If the gas supply is to be routed through the side of the enclosure remove the (3) screws from the cover plate so the hole is exposed. Snap the bushing into the side panel to secure the hose in place. Slide the cover plate over, and reinstall.

The gas supply is shown entering the bottom of the enclosure.

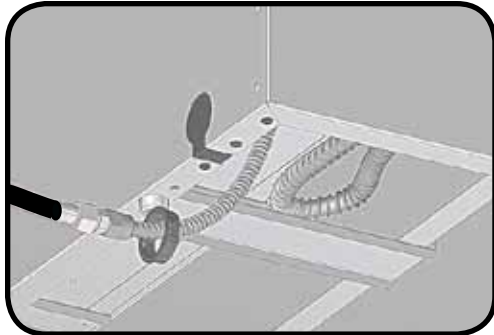

2. The burner unit can be used either with or without the enclosure. Simply lift the unit out of the enclosure to separate. A second person is required to guide out the gas hose /regulator when removing the burner unit from the enclosure. The burner unit can be placed directly on combustible surfaces, but the required clearances to the sides and top must still be maintained.

Two people are required to lift burner unit from enclosure

Lift burner unit from enclosure using handles

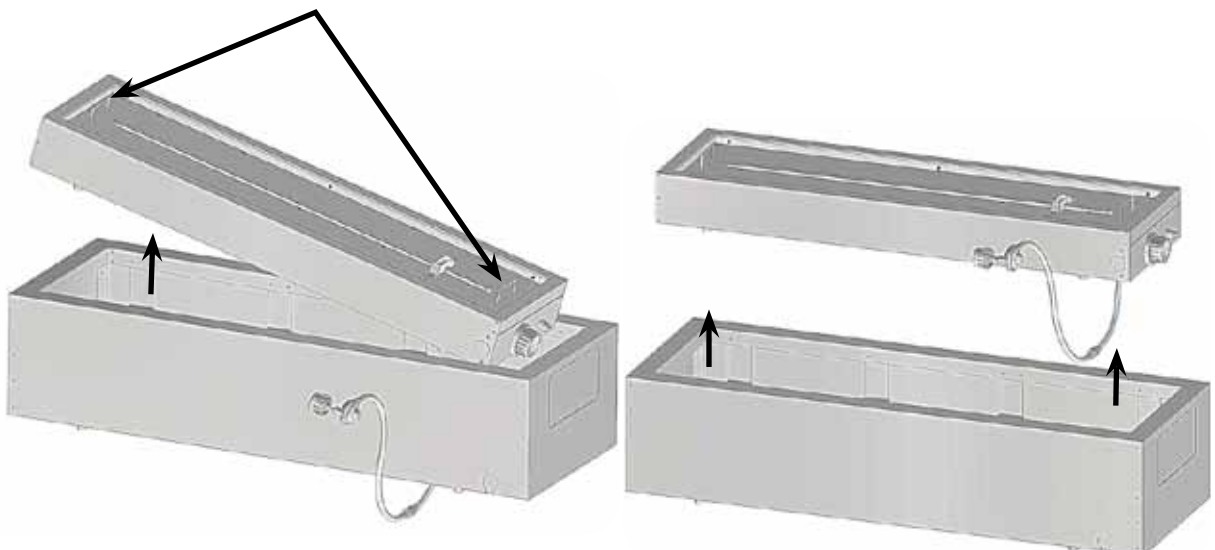

- The supply can feed either into the side of the burner base, or is fed from below the base. The gas line needs to be disconnected from the gas valve and reconnected in order to do this. This must be done by a licensed gas fitter and the connections need to be leak tested according to the leak testing instructions before using the unit.

The gas supply is shown entering the bottom of the burner.

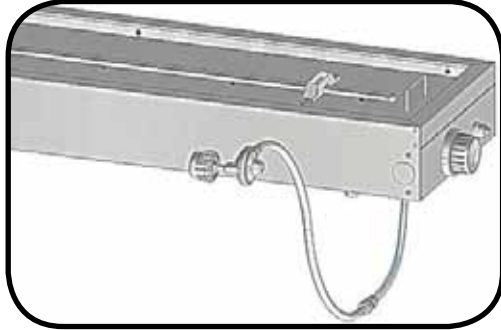

The gas supply is shown entering the side of the burner.

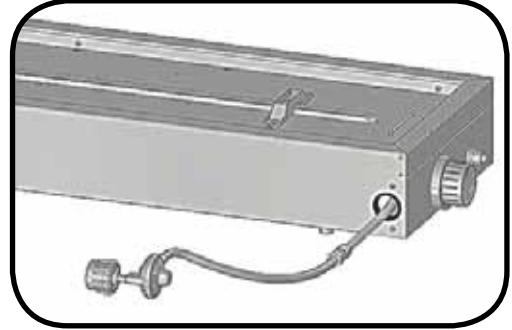

- The burner unit can be built into a non-combustible enclosure. The control module can be removed from the burner unit and located up to 12" away from the burner unit. A cap is provided to close the opening in the side of the burner module. The gas line needs to be disconnected and reconnected in order to do this. This must be done by a licensed gas fitter and the connections need to be leak tested according to the leak testing instructions before using the unit.

Removing Control Panel

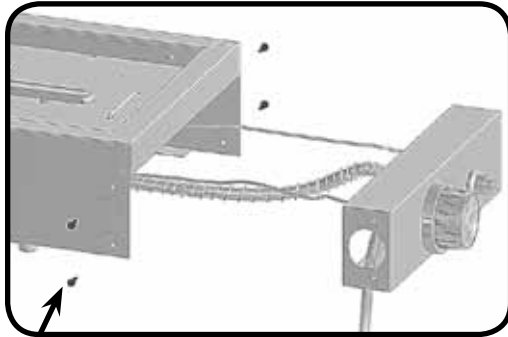

4 x N570-0013



WARNING! Cabinet frame, cabinet and counter top must be made from non-combustible material.



WARNING! You must have clear and easy access to the on/off valve AFTER the appliance is installed and connected to the gas supply in order to safely turn off the burner.



WARNING! Materials placed around the burner unit will get extremely hot. They must be non-combustible and must be able to expand and contract without cracking. Raise the burner unit above the enclosure by (3/4") to reduce the temperature of the enclosure surface. Tiled cement board is the preferred material.

Raise the burner unit by 3/4"
above the enclosure surface
as illustrated.

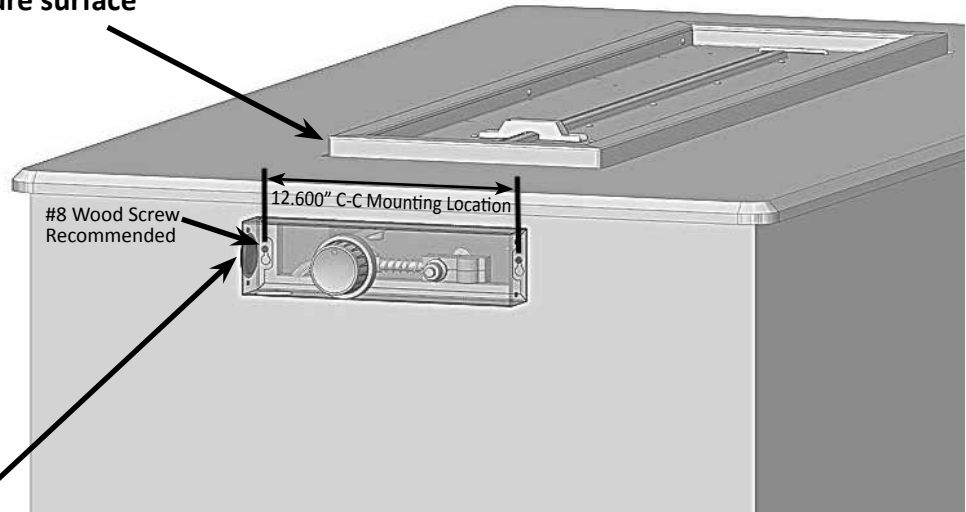

Insert cap (N510-0012) into end of
control panel as shown.

Gas Hook-Up Instructions



WARNING! If these instructions are not followed exactly, a fire causing death or serious injury may occur.

Propane Cylinder Specifications

A dented or rusty cylinder may be hazardous and should be checked by your propane supplier. Never use a cylinder with a damaged valve. Use only a propane supply cylinder constructed and marked in accordance with the specifications for LP-gas cylinders of the National Standard of Canada, CAN/CSA-b339, Cylinders, Spheres and Tubes for Transportation of Dangerous Goods; and Commission, as applicable or the Specifications for LP-Gas Cylinders of the U.S. Department of Transportation (D.O.T.). This appliance has been designed for use with a 20 lb. (9.1 kg) or 30 lb (13.6 kg) size propane cylinder only (not supplied).

The propane cylinder must be provided with a cylinder connection device compatible with the connection for outdoor appliances. The propane cylinder must be provided with a shut-off valve terminating in a propane cylinder valve type QCC1, and a safety relief device having direct communication with the vapor space of the cylinder. The cylinder supply system must be arranged for vapor withdrawal and the cylinder shall include a collar to protect the cylinder valve. The cylinder shall incorporate a listed OPD (overfill protection device). Do not store a spare LP-gas cylinder under or near this appliance. Never fill the cylinder beyond 80 percent full.

Use only the pressure regulator and hose assembly provided with this appliance. Replacement pressure regulators and hose assemblies must be specified by the manufacturer. The regulator supplies a pressure of 11 inches. water column to the appliance and has a QCC1 type fitting. Cylinders to be used with this unit must be supplied with a QCC1 cylinder valve. A QCC1 cylinder has a positive seating connection, which will not allow gas flow until a positive seal has been achieved. It is also equipped with an excess flow device. In order to attain full flow to the appliance, the valve must be in the off position when the cylinder valve is turned on.



WARNING! A fire will result if the gas supply hose makes contact with the underside of the appliance.

LP (Propane) Gas

Attach cylinder retaining bracket supplied to the base of the cylinder. Then secure to the surface to which it sits. Cylinder should be on a level surface.

Cylinder Retaining Bracket

1. Fasten the bracket to the bottom of the propane bottle using bolt and nut supplied.
2. Tighten the lag screw into the mounting surface leaving approximately 1/4" of thread above the surface.
3. Slide propane bottle into position so that the bracket slides under the head of the lag screw.
4. Tighten the lag screw onto the bracket.
5. For fastening to a concrete surface a concrete anchor will be required. (Not supplied)

Cylinder Connection: Ensure the gas regulator hose is kink free. Remove the cap or plug from the cylinder fuel valve. Insert the black QCC1 regulator nipple onto the QCC1 fuel valve. Hand tighten clockwise. Do not use tools. Leak test all joints prior to using the appliance. A leak test must be performed annually and each time a cylinder is hooked up or if a part of the gas system is replaced.

If this appliance is to be connected directly to a house propane gas supply line, follow the instructions for the natural gas hook-up.

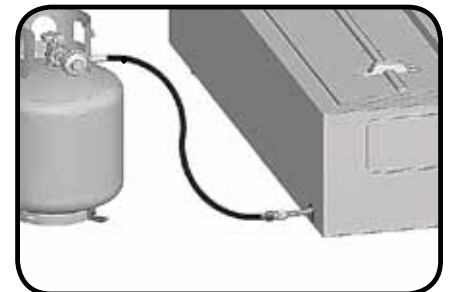
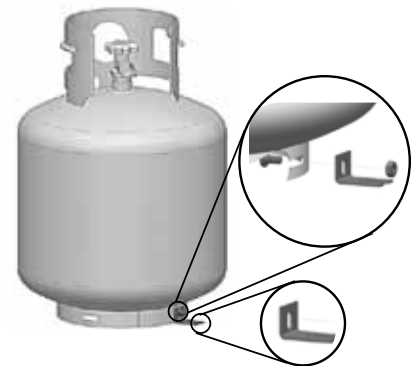



CAUTION!

- Make sure cylinder valve is in its full off position. (Turn clockwise to stop).
- Check cylinder valve features to ensure it has proper external mating threads. (Cylinder Valve Marked: USE WITH TYPE 1)
- Inspect hose shipped with the unit for damage. Never attempt to use damaged or plugged equipment. See your local LP Gas Dealer for repairs.
- When connecting regulator assembly to the cylinder valve, hand tighten black QCC1 nut clockwise to a positive stop. DO NOT use a wrench to tighten. Use of a wrench may damage the quick closing coupling nut and result in a hazardous condition.
- Locate the hose out of pathways where people may trip over it or in areas where the hose may be subject to accidental damage.
- Open cylinder valve fully (counter-clockwise). Turn the on/off valve at the unit slowly to the on position and use a soapy water solution to check all connections for leaks as indicated in the diagrams before attempting to light the appliance. If a leak is found, turn tank valve off and do not use the appliance until repairs can be made.

Enclosures For LP (Propane) Gas Supply Systems

If you build an enclosure for an LP gas cylinder, follow these recommended specifications. You must also follow local codes.

- An enclosure for an LP-gas cylinder shall be ventilated by openings at both the upper and lower levels of the enclosure.

This shall be accomplished by one of the following:

One side of the enclosure shall be completely open;

OR

For an enclosure having four sides, a top, and a bottom:

a) At least two ventilation openings shall be provided in the sidewalls of the enclosure, located within 5 in (127 mm) of the top of the enclosure, equally sized, spaced at 180 degrees, and unobstructed. The opening(s) shall have a total free area of not less than 1 in² per lb (14.2 cm² / kg) of stored fuel capacity.

b) Ventilation opening(s) shall be provided at floor level of the enclosure and shall have a total free area of not less than 1/2 in² per lb (7.1 cm² / kg) of stored fuel capacity. If ventilation openings at floor level are in a side wall, there shall be at least two openings. The bottom of the openings shall be 1 in (25.4 mm) or less from the floor level and the upper edge no more than 5 in (127 mm) above the floor level. The openings shall be equally sized, spaced at 180 degrees, and unobstructed.

c) Every opening shall have minimum dimensions so as to permit the entrance of a 1/8 inch (3.2mm) diameter rod.

Ventilation openings in sidewalls shall not communicate directly with other enclosures of the appliance.

Cylinder valves shall be readily accessible for hand operation. A door on the enclosure to gain access to the cylinder valve is acceptable, provided it is non-locking and can be opened without the use of tools. Designs using a cover to gain access to the cylinder and cylinder valve shall be provided with handles or equivalent at a minimum of 180 degrees apart to facilitate lifting of the cover.

There shall be a minimum clearance of 2 inches (50.8mm) between the lower surface of the floor of the LP gas supply cylinder enclosure and the ground.

The design of the enclosure shall be such that (1) the LP gas supply cylinder(s) can be connected, disconnected and the connections inspected and tested outside the cylinder enclosure; and (2) those connections which could be disturbed when installing the cylinder(s) in the enclosure can be leak tested inside the enclosure.

The enclosure for the LP-gas cylinder shall isolate the cylinder from the burner compartment to provide:

- Shielding from radiation;
- A flame barrier; and
- Protection from foreign material.

Be certain to mount or set the LP gas cylinder on a flat surface and restrain it using the cylinder retaining bracket to prevent it from tipping.

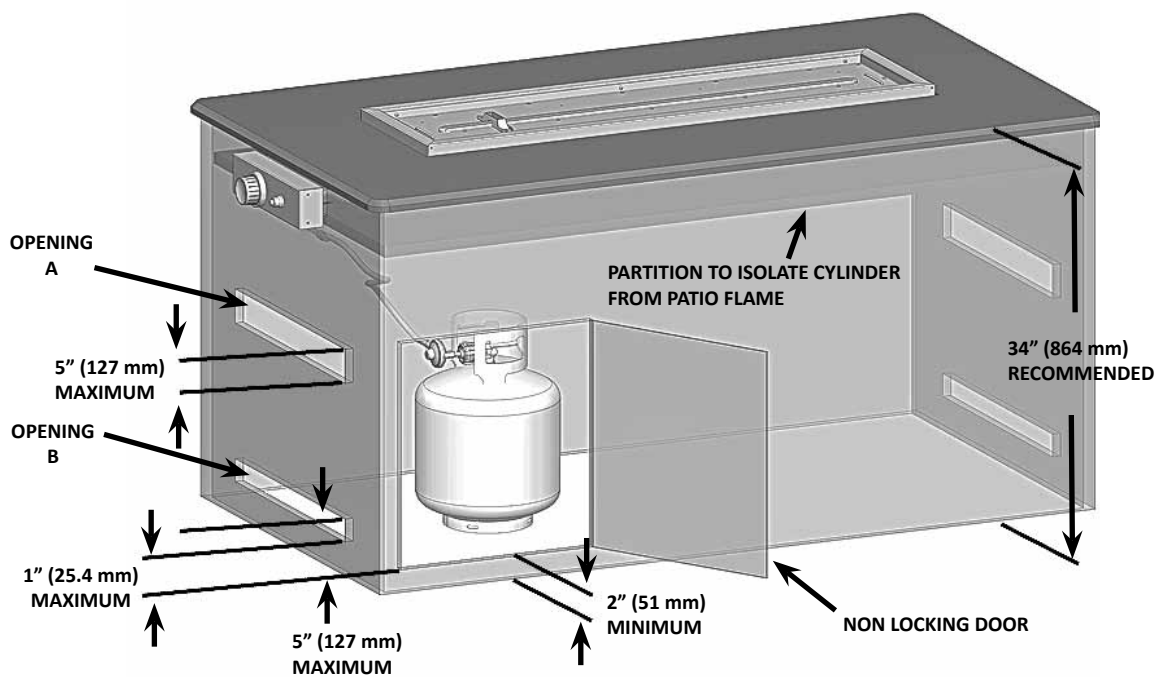

CYLINDER SIZE	OPENING A AREA	OPENING B AREA
20 lb (9.1 kg)	20 in ² (130 cm ²)	10 in ² (65 cm ²)
30 lb (13.6 kg)	30 in ² (195 cm ²)	15 in ² (100 cm ²)

Conversion to Natural Gas



WARNING! To avoid the possibility of burns conversions should only be done when the patio flame is cool. Ensure burner is turned off. Turn gas off at source and disconnect the patio flame before beginning conversion.



WARNING! Glass embers may have sharp edges wear safety glasses and gloves when handling.



WARNING! This conversion must be performed by a licensed gas fitter, and all connections must be leak tested before operating the patio flame.

Your patio flame can be easily converted to natural gas by following these steps:

1. Remove glass embers from the tray.
2. Remove the glass tray from the patio flame by removing the (18) screws that hold the tray in place.
3. Carefully lift the glass tray from the patio flame and set aside. Take care not to damage or kink the thermocouple wire.

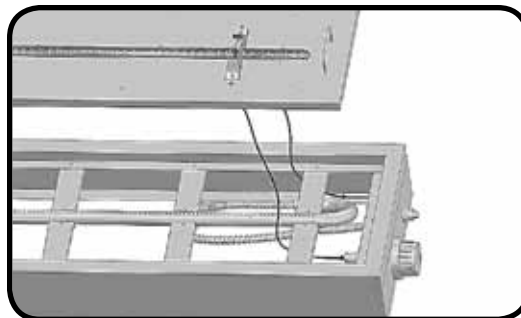
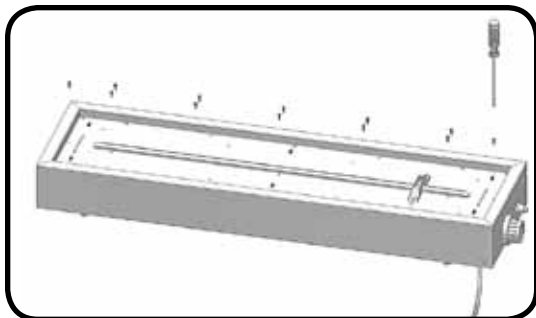

4. Disconnect the stainless steel flex connector from the orifice using (2) wrenches.

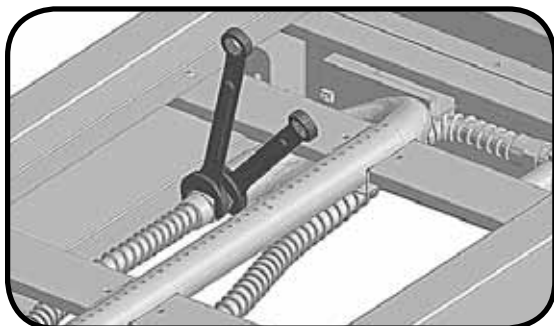

5. Unscrew the propane orifice from the inside of the burner as illustrated.

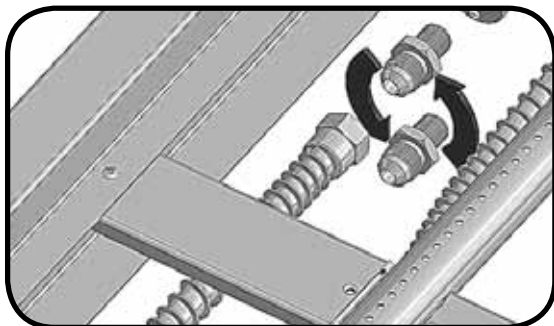

6. Replace the propane orifice with the natural gas orifice supplied.

Note: The air shutter has been factory set and does not need to be adjusted.

7. Reconnect the stainless steel flex connector to the orifice and tighten using (2) wrenches.
8. Place the glass tray over the burner and fasten to the patio flame with the screws removed in step 2.
9. A leak test must be performed according to the leak testing instructions found in the manual.

Natural Gas Hook-Up

The gas appliance is designed to operate at an inlet pressure of 7 inches water column. The piping up to the appliance is the responsibility of the installer. A flexible metal connector is included to simplify the installation of the unit. Connect the flexible connector to rigid pipe, copper tube or an approved flexible metal connector, which complies with Z21.4/CSA 6.10. If using a gas hose (not supplied) connect the flared end of the hose to the connector on the end of the flex tube as illustrated. Tighten using two wrenches. (Do not use thread sealer/pipe dope.) Leak test all joints prior to using the appliance. Piping and valves upstream of the quick disconnect are not supplied. The gas supply pipe must be sufficiently sized to supply the BTU/h specified on the rating plate, based on the length of the piping run. The quick disconnect must not be installed in an upward direction and a readily accessible manual shut-off valve must be installed upstream of, and as close to, the quick disconnect as is feasible.

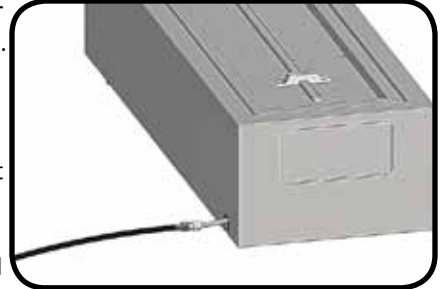

Purge the gas supply line of any trapped air prior to the first firing of the unit.



WARNING!

- The installation must be performed by a licensed gas fitter, and all connections must be leak tested before operating the grill.
- Ensure all hose connections are tightened using two wrenches. Do not use Teflon tape or pipe dope on any hose connection.
- Ensure the hose does not contact any high temperature surfaces or it may melt and leak causing a fire.
- Locate the hose out of pathways where people may trip over it or in areas where the hose may be subject to accidental damage.
- Leak test all the connections using a soap and water solution as per the leak testing instructions found in the manual.

Finishing

Glass Ember Installation



WARNING! Glass embers may have sharp edges, wear safety glasses and gloves when handling. Do not change or substitute the glass ember material provided with this appliance. If replacing, use only replacement glass embers available from your local authorized dealer / distributor.

WARNING! Glass embers may have a fine oil residue that needs to be cleaned prior to installation. Clean the glass with mild dish soap, drain, rinse thoroughly and dry before installing.

1. Carefully pour the glass embers onto the appliance ember tray as shown.
2. Spread the glass embers over the tray and burner. The distribution of clear glass over the burner will influence flame height.
3. Ensure no glass is placed on the ignition portion of the burner.

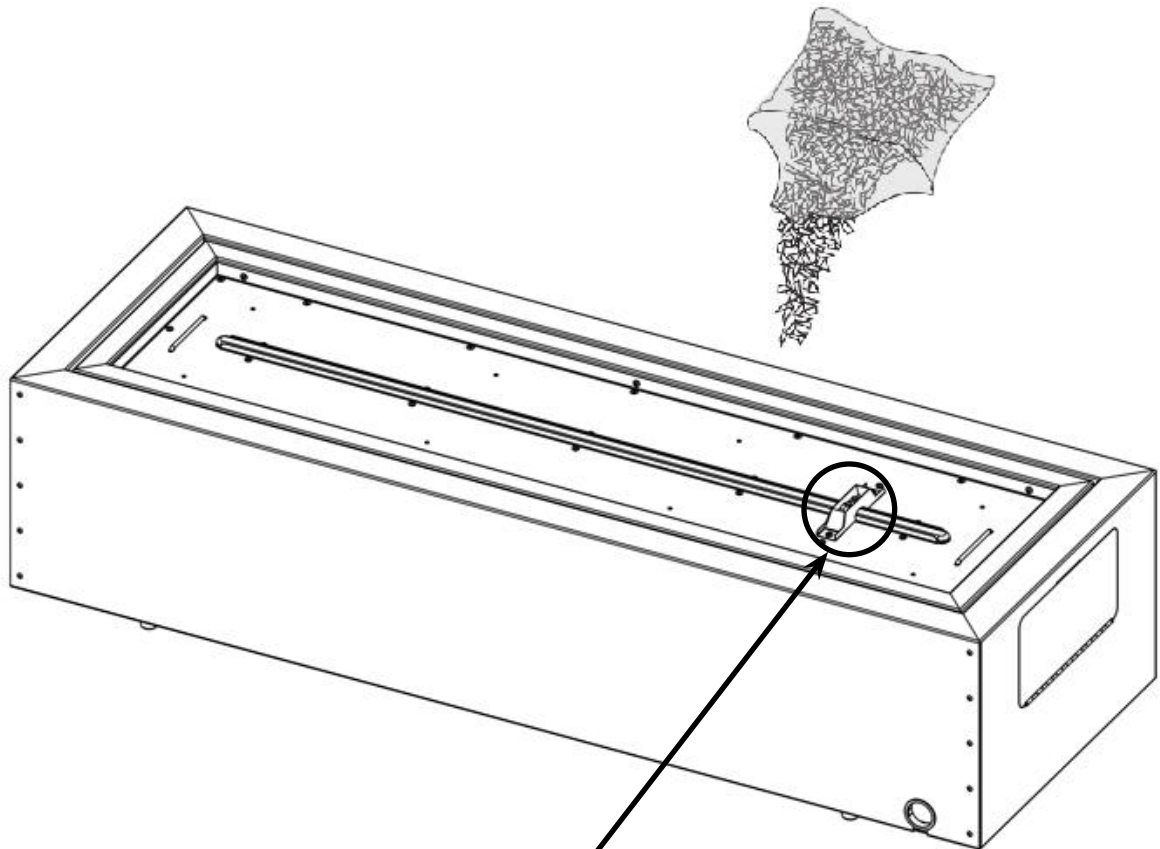

**ENSURE NO GLASS IS PLACED ON THE IGNITION PORTION OF THE BURNER,
DIFFICULTIES IN LIGHTING MAY RESULT.**

Leak Testing Instructions



WARNING! A leak test must be performed annually, or if a part of the gas system is replaced.



WARNING! Never use an open flame to check for gas leaks. Be certain no sparks or open flames are in the area while you check for leaks. Sparks or open flames will result in a fire or explosion, damage to property, serious bodily injury, or death.



Leak testing: This must be done before initial use, annually, and whenever any gas components are replaced or serviced. Do not smoke while performing this test, and remove all sources of ignition. See Leak Testing Diagram for areas to check. Turn all burner controls to the off position. Turn gas supply valve on.



Brush a half-and-half solution of liquid soap and water onto all joints and connections of the regulator, hose, manifolds and valves.



Bubbles will indicate a gas leak. Either tighten the loose joint or have the part replaced with one recommended by the Napoleon Customer Care department and have the grill inspected by a certified gas installer.

If the leak cannot be stopped, immediately shut off the gas supply, disconnect it, and have the grill inspected by a certified gas installer or dealer. Do not use the grill until the leak has been corrected.

DO NOT USE AN OPEN FLAME.

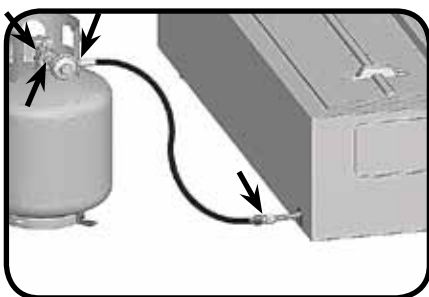

DO NOT USE AN OPEN FLAME.

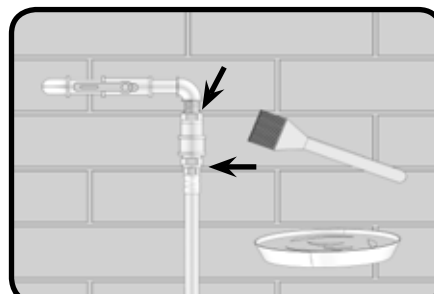
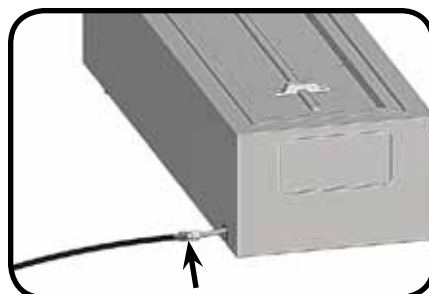

Lighting Instructions

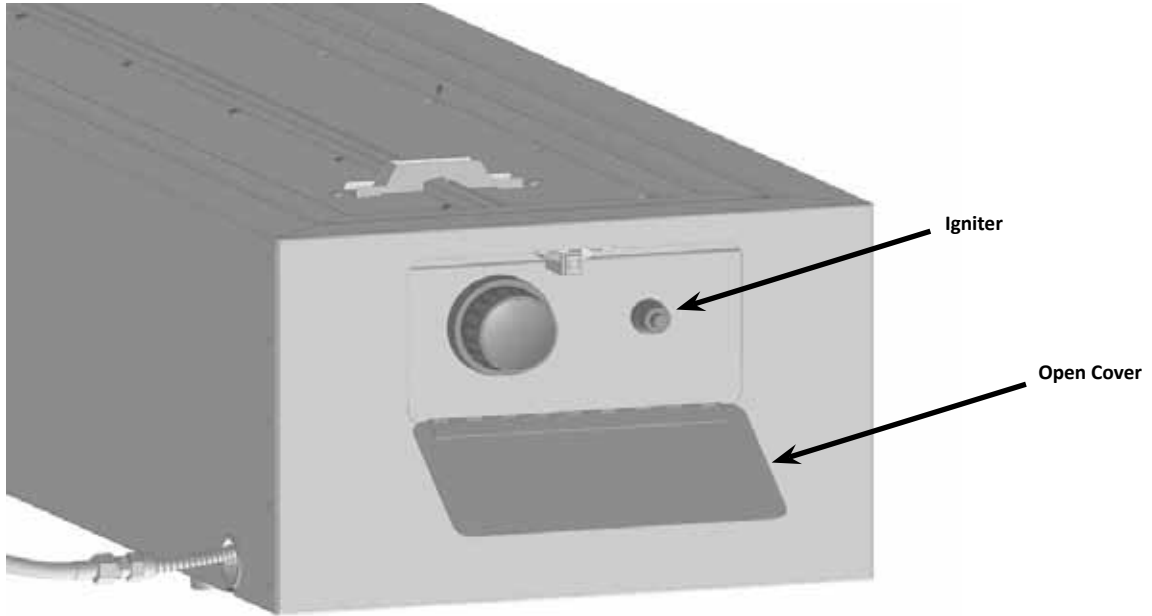

WARNING! Never use the appliance when it is raining. A cover has been provided to protect the burner and glass embers when not in use. Remove the cover before starting the appliance.

WARNING! Keep face and body away from burner area when lighting.

WARNING! Ensure burner controls are in the off position. Slowly turn on the gas supply valve.

1. Press and hold electronic igniter button (⚡).

2. Turn the burner control to the high position, press and hold in. When the burner lights, release the electronic igniter button.

3. Continue to depress the burner control knob for 30 seconds and then release. If the flame goes out, repeat the procedure.

4. Adjust the flame to the desired height with the burner control knob.

5. If the burner will not light with the electronic igniter, hold a lit long match or lit long butane lighter to the ignition area of the burner and continue with step 2.

6. To shut down the burner turn the burner control knob clockwise to the off position. Then turn the gas off at the source (propane cylinder valve or natural gas supply valve).



WARNING! The propane cylinder is equipped with an excess flow device. Unless burners are turned off prior to turning the cylinder on, only small flames and low heat will be achievable.

If lighting the unit with a match, clip the match into the supplied lighting rod.



Operating The Patio Flame



WARNING! Never use this patio flame for other than the intended use. Do not use this appliance to prepare food.



WARNING! You must have clear and easy access to the on/off valve AFTER the appliance is installed and connected to the gas supply in order to safely turn off the burner.

Initial Lighting: When lit for the first time, the patio flame emits a slight odor. This is a normal temporary condition caused by the “burn-in” of internal paints and lubricants used in the manufacturing process and does not occur again. Simply run the main burner on high for approximately one-half hour.



WARNING!

- Children and adults should be alerted to the hazards of high surface temperatures and should stay away from the patio flame to avoid burns or clothing ignition.
- Children should be carefully supervised when they are in the area of the patio flame.
- Clothing or other flammable materials should not be hung from the patio flame, or placed on or near the patio flame. The area above the enclosure may be extremely hot. Direct contact with these metal surfaces should be avoided in order to prevent burns or clothing ignition.
- Any guard or protective device removed for servicing the patio flame must be replaced prior to operating the patio flame.
- Installation and repair should be done by a qualified service person. The patio flame should be inspected before each use and at least annually by a qualified service person. More frequent cleaning may be required as necessary. It is imperative that the control compartment, burners and circulating air passageways of the patio flame be kept clean.



WARNING!

- Never use the patio flame while it is raining.
- Always turn the patio flame off when raining.
- Never splash any liquid on the glass embers when the patio flame is operating.
- The glass embers will be extremely hot while operating, never try to touch them.
- Always ensure the patio flame stands firmly on level ground.
- Never use the patio flame if the burner is damaged. Inspect the burner before each use. Ensure that no debris such as leaves; grass or other objects have entered or are on the patio flame. If the burner is damaged it must be replaced prior to using the patio flame with a replacement burner specified by your Napoleon dealer.
- Inspect the hose assembly before each use. If there is evidence of excessive abrasion or wear, or if the hose is damaged it must be replaced prior to using the patio flame with a replacement hose assembly specified by your Napoleon dealer.

NOTE! The patio flame has been designed with several safety features, which include a safety valve. If the burner flame is extinguished the patio flame will automatically shut down.



WARNING! Any modification to the patio flame may compromise the safety of this appliance. Special concern is as follows.

- Do not bypass thermocouple safety.
- Do not operate patio flame if any part has been under water. Immediately call a qualified service technician to inspect the unit and replace any part of the control system and any gas control, which has been underwater.

Maintenance / Cleaning Instructions



WARNING! Glass embers may have sharp edges, wear safety glasses and gloves when handling. Do not change or substitute the glass ember material provided with this appliance. If replacing, use only replacement glass embers available from your local authorized dealer / distributor.



WARNING! To avoid the possibility of burns, maintenance should be done only when the patio flame is cool. Avoid unprotected contact with hot surfaces. Ensure burner is turned off. Turn gas off at source and disconnect the patio flame before servicing. Clean the patio flame in an area where cleaning solutions will not harm decks, lawns, or patios. Do not use flammable, corrosive or abrasive cleaners.



Note: Stainless steel tends to oxidize or stain in the presence of chlorides and sulfides, particularly in coastal areas and other harsh environments, such as the warm, highly humid atmosphere around pools and hot tubs. These stains could be perceived as rust, but can be easily removed or prevented. To provide stain prevention and removal, wash all stainless steel surfaces every 3-4 weeks or as often as required with fresh water and/or stainless steel cleaner.

Control Panel: The control panel text is printed directly on the stainless steel and with proper maintenance will remain dark and legible. To clean the panel, use only warm soapy water or stainless steel cleaner available from your Napoleon dealer. Never apply abrasive cleaners on any stainless surfaces, especially the printed portion of the control panel or the printing will gradually rub off.



WARNING! Hose: Check for abrasions, melting, cuts, and cracks in the hose. If any of these conditions exist, do not use the patio flame. Have the part replaced by your Napoleon dealer or qualified gas installer.

Cleaning Inside The Patio Flame: While washing your patio flame, be sure to keep the area around the burner and pilot assembly dry at all times.



WARNING! If the gas control is exposed to water in any way, DO NOT try to use the patio flame. The gas control must be replaced.

Burner: The burner is made from heavy wall 304 stainless steel, but extreme heat and a corrosive environment can cause surface corrosion to occur. This can be removed with a brass wire brush. Inspect the burner at least annually for cracks, insect nests, excessive corrosion or any other damage. If the burner is damaged, it must be replaced with a burner specified by the manufacturer before the appliance is put into operation.



CAUTION! Beware of Spiders.

Spiders and insects are attracted to the smell of propane and natural gas. The burner is equipped with an insect screen on the air shutter, which reduces the likelihood of insects building nests inside the burner but does not entirely eliminate the problem. A nest or web can cause the burner to burn with a soft yellow or orange flame or cause a fire (flashback) at the air shutter underneath the control panel. Other warning signs that may indicate a problem are:

- Strong or unusual odor coming from the patio flame.
- Continued difficulty or delayed ignition.
- Flame appears either very short or very long.
- Flame only burns part way across the burner.
- Excessive soot building up on the glass embers.

To clean the inside of the burner, it must be removed from the patio flame: Remove the glass embers and examine the burner. If dirty, clean with a wire brush. Remove the screws that attach the glass ember tray and the nuts from the bottom of the burner. Slide the burner back and up wards to remove.

Cleaning: Use a flexible venturi tube brush to clean the inside of the burner. Shake any loose debris from the burner through the gas inlet. Check the burner ports and valve orifices for blockages. Burner ports can close over time due to debris and corrosion, use an opened paperclip or a drill bit to clean them. The ports are easier to clean if the burner is removed from the patio flame, but it can also be done with the burner installed.

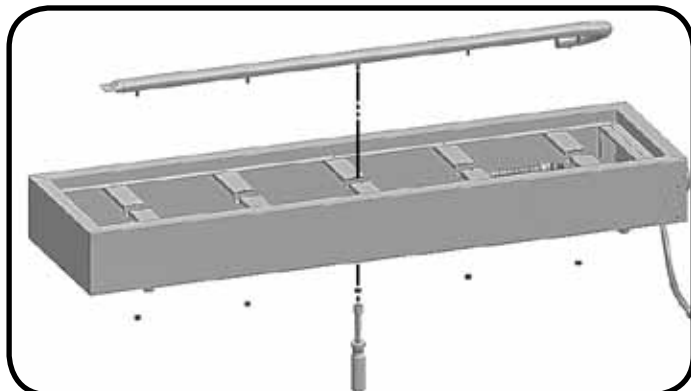
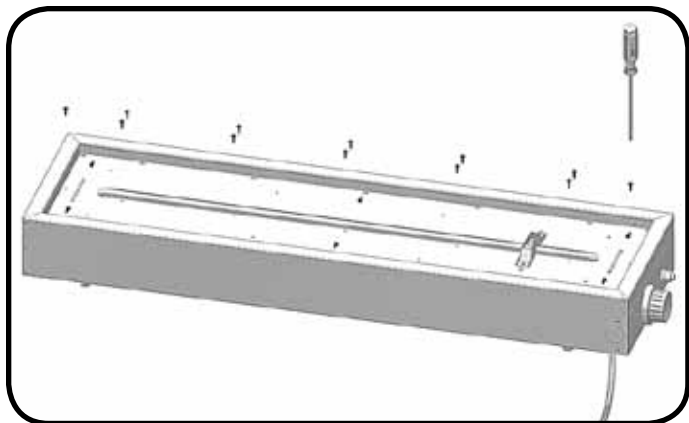

Reinstallation: Reverse the procedure to reinstall the burner. Check that the valve enters the burner when installing. Replace the glass embers. When the appliance is put back in service, check the burner flame pattern with the image below.

NORMAL



ABNORMAL

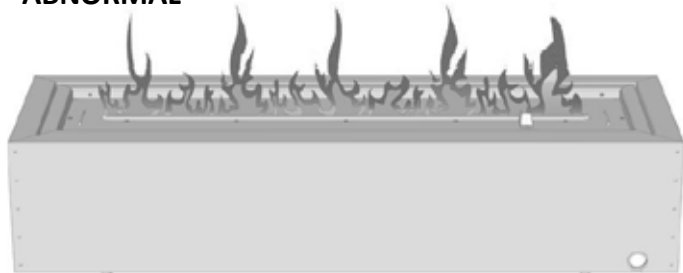

Cleaning The Outer Patio Flame Surface: Do not use abrasive cleaners or steel wool on any painted, or stainless steel parts of your Napoleon Patio Flame. Doing so will scratch the finish. Exterior heater surfaces should be cleaned with warm soapy water. To clean stainless surfaces, use a stainless steel or a non-abrasive cleaner. Always wipe in the direction of the grain. Over time, stainless steel parts discolor when heated, usually to a golden or brown hue. This discoloration is normal and does not affect the performance of the patio flame.



WARNING! The patio flame area must be clear and free from combustible materials, gasoline and other flammable vapors and liquids. Do not obstruct the flow of combustion and ventilation air. Keep the ventilation opening of the cylinder enclosure free and clear of debris.

Troubleshooting

Problem	Possible Causes	Solution
Low heat / Low flame when valve turned to high.	For propane - improper lighting procedure. For natural gas - undersized supply line.	Ensure lighting procedure is followed carefully. The valve must be in the off position when the tank valve is turned on. Turn tank on slowly to allow pressure to equalize. See lighting instructions. Pipe must be sized according to installation code.
Burners burn with yellow flame, accompanied by the smell of gas.	Possible spider web or other debris.	Thoroughly clean burner venturi. See general maintenance instructions.
Burner will not light with the igniter, but will light with a match.	Dead battery / or installed incorrectly. Loose electrode wire or switch terminal wires. Improper gap at electrode tip.	Replace with heavy duty battery. Check that electrode wire is firmly pushed onto the terminal on the back of the igniter. Check that the lead wires from the module to the ignition switch (if equipped) are firmly pushed onto their respective terminals. The gap can be adjusted by bending the tip in or out. Until a spark is achieved.
Burner will not stay lit when control knob is released.	Knob not being held in long enough. Too windy. Glass or debris in ignition area of the burner preventing thermocouple from being fully engulfed in flame. Dirty thermocouple or thermocouple connection. Faulty thermocouple or valve.	Thermocouple must have time to heat up – hold the knob in for 30 seconds after the burner lights, then release Unit will shut down if winds are greater than 10mph (16km/h). Either locate to different area or use when it is less windy. Ensure there is no glass or other debris in ignition area, and that the small hole below the thermocouple is unobstructed. Clean the thermocouple and clean the connection between the valve and thermocouple. Ensure the connection is properly tightened. Replace thermocouple and / or valve.
Humming regulator.	Normal occurrence on hot days.	This is not a defect. It is caused by internal vibrations in the regulator and does not affect the performance or safety of the gas heater. Humming regulators will not be replaced.
Burner output on “high” setting is too low. (Rumbling noise and fluttering blue flame at burner surface.)	Lack of gas. Supply hose is pinched. Dirty or clogged orifice. Spider webs or other matter in venturi tube. Propane regulator in “low flow” state.	Check gas level in propane cylinder. Reposition supply hose as necessary. Clean burner orifice. Clean out venturi tube. Ensure lighting procedure is followed carefully. All valves must be in the off position when the tank valve is turned on. Turn tank on slowly to allow pressure to equalize. See lighting instructions.

KEEP YOUR RECEIPT AS PROOF OF PURCHASE TO VALIDATE YOUR WARRANTY.

Ordering Replacement Parts

Warranty Information

MODEL: _____

DATE OF PURCHASE: _____

SERIAL NUMBER: _____

(Record information here for easy reference)

Before contacting the Customer Care Department, check the NAC Website for more extensive cleaning, maintenance, troubleshooting and parts replacement instructions at www.napoleongrills.com. Contact the factory directly for replacement parts and warranty claims. Our Customer Care Department is available between 9 AM and 5 PM (Eastern Standard Time) at 1-866-820-8686 or fax at 1-705-727-4282. To process a claim, we must be provided with the following information:

1. Model and serial number of the unit.
2. Part number and description.
3. A concise description of the problem ('broken' is not sufficient).
4. Proof of purchase (photocopy of the invoice).

In some cases the Customer Care Representative could request to have the parts returned to the factory for inspection before providing replacement parts. These parts must be shipped prepaid to the attention of the Customer Care Department with the following information enclosed:

1. Model and serial number of the unit.
2. A concise description of the problem ('broken' is not sufficient).
3. Proof of purchase (photocopy of the invoice).
4. Return Authorization Number - provided by the Customer Care Representative.

Before contacting customer care, please note that the following items are not covered by the warranty:

- Costs for transportation, brokerage or export duties.
- Labor costs for removal and reinstallation.
- Costs for service calls to diagnose problems.
- Discoloration of stainless steel parts.
- Part failure due to lack of cleaning and maintenance, or use of improper cleaners (oven cleaner).

Parts List

Item	Part #	Description	
1	n010-0699	base	x
2	w272-0001	foot, rubber	x
3	n570-0013	#8 x 5/8" screw	x
4	n100-0043	main burner	x
	n565-0008	replacement screen	x
5	n450-0025	1/4" - 20 nut	x
6	n475-0289	control panel	x
7	n725-0049	safety valve	x
8	n051-0007	control knob bezel	x
9	n380-0016r	burner control knob	x
10	n720-0044	flex connector 12" X 3/8"	x
11	n255-0027	union fitting 3/8" - 3/8"	x
12	n010-0281	flex connector 30" X 3/8"	x
13	w455-0076	orifice propane #43	p
	n455-0066	orifice natural #25	n
14	w530-0023	regulator hose assembly	p
15	n510-0012	plug,black snap in 1 3/4"	x
16	n357-0013	igniter 1 spark - AAA 1.5V	x
17	n043-0002	battery, AAA 1.5V	x
18	n710-0071	glass tray	x
19	n080-0274	bracket electrode - thermocouple	x
20	n585-0077	wind shield	x
21	n570-0022	#8-32x3/8 screw	x
22	n680-0001	thermocouple	x
23	n240-0028	electrode c/w lead	x
24	n570-0008	#8x1/2" screw	x
25	n325-0074	handle glass tray	x
26	n570-0013	#8 x 5/8" screw	x
27	n105-0002	bushing snap 1.5"	x
28	n200-0095	cover unit	x
29	n735-0003	1/4" lock washer	x
30	n570-0073	1/4-20 X 3/8 screw	x
31	n325-0049	handle cover	x
32	n010-0700hs	enclosure assembly	x
33	n430-0006	magnetic catch	x
34	n570-0058	6-32 X 1/4" screw	x
35	n080-0277	bracket supply cover	x
36	w080-0761	bracket tank retainer	x
37	n300-0002	glass embers - topaz 2 x 7.5lb	x
	n345-0001	natural gas hose 10ft	ac
	mega	glass embers - amber 1lb	ac
	megb	glass embers - blue 1lb	ac
	megk	glass embers - black 1lb	ac
	megr	glass embers - red 1lb	ac

Parts List

Item	Part #	Description	
	mkgc	glass embers - clear 6lb	ac
	mkgk	glass embers - black 6lb	ac
	mkgb	glass embers - blue 6lb	ac
	mkgr	glass embers - red 6lb	ac

x - standard

p - propane units only

n - natural gas units only

ac - accessory

Parts Diagram

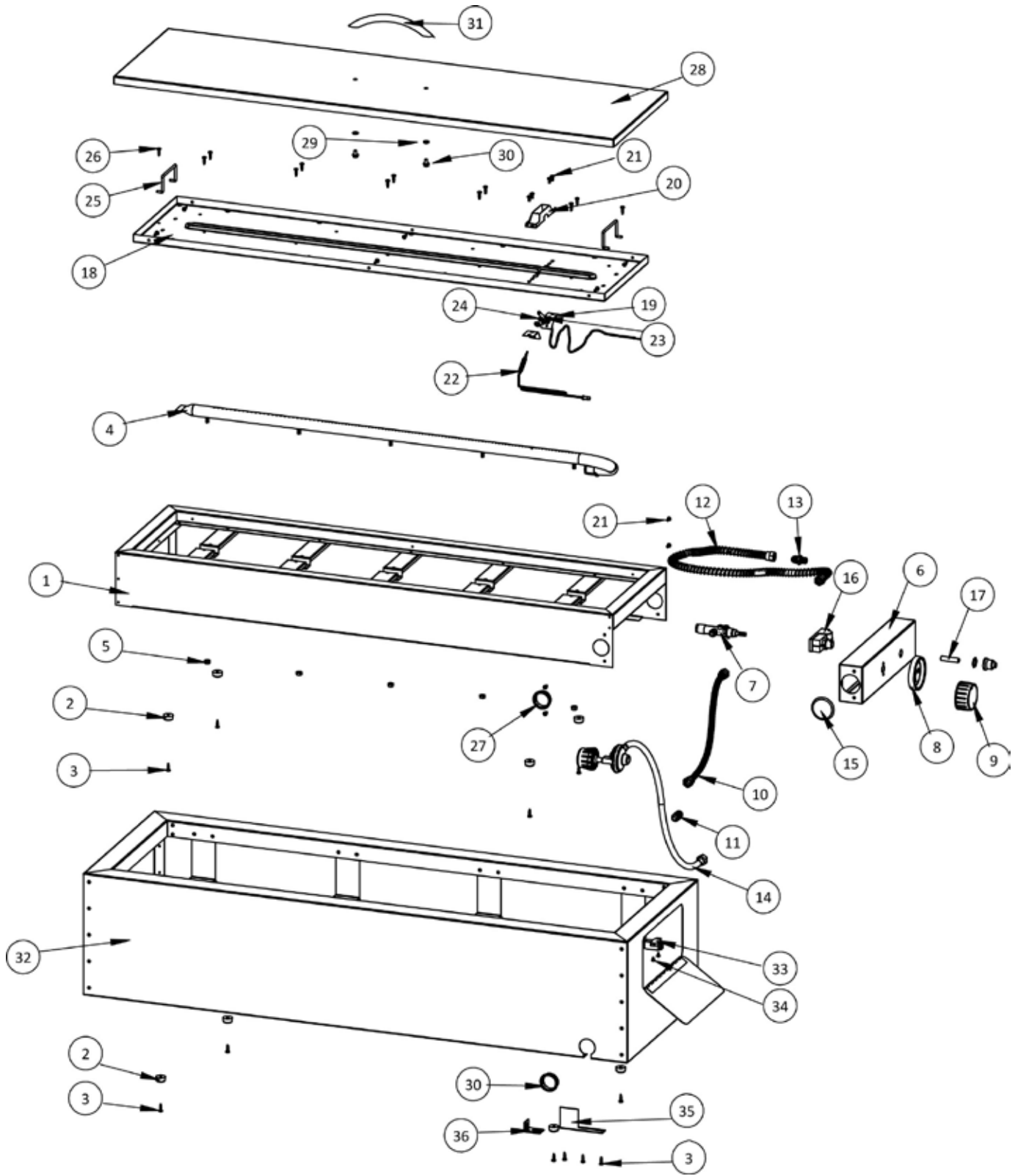



FAX TO: 705 727 4282

ACCESSORIES & PARTS ORDER FORM

PLEASE PRINT CLEARLY

CONTACT NAME: _____

SHIP TO : _____

TEL : _____

FAX : _____

EMAIL: _____

VISA OR MASTERCARD # : _____

EXPIRY DATE: _____

SIGNATURE: _____

QUANTITY	PART NUMBER	DESCRIPTION

TAXES MAY APPLY
SHIPPING EXTRA

IF CONFIRMATION IS REQUIRED PLEASE INCLUDE A FAX NUMBER OR EMAIL ADDRESS



TÉLÉCOPIEZ AU: 705 727 4282

BON DE COMMANDE POUR PIÈCES/ACCESSOIRES

NOM DU CLIENT _____

ADRESSE: _____

TÉLÉPHONE : _____ FAX : _____

EMAIL: _____

VISA OU MASTERCARD : _____ DATE D'EXPIRATION : _____

SIGNATURE: _____

QUANTITÉ	NUMÉRO DE PRODUIT	DESCRIPTION

LES TAXES PEUVENT S'APPLIQUER
LES FRAIS D'EXPEDITION SUPPLÉMENTAIRE

**SI VOUS DÉSIREZ RECEVOIR UNE CONFIRMATION, VEUILLEZ INCLURE UN NUMÉRO DE
TÉLÉCOPIEUR OU UNE ADRESSE COURRIEL**