



**FRIEDRICH**

**Floating Air Select**



- FSHW091 - 9,000 BTU Single Zone - 110V**
- FSHW121 - 12,000 BTU Single Zone - 110V**
- FSHW183 - 18,000 BTU Single Zone - 230V**
- FSHW243 - 24,000 BTU Single Zone - 230V**
- FSHW363 - 36,000 BTU Single Zone - 230V**

# TABLE OF CONTENTS

|  |     |
|--|-----|
| INTRODUCTION-  | 4   |
| Important Safety Information-  | 4   |
| Personal injury or death hazards-  | 6   |
| Model identification guide-  | 7   |
| Indoor Units-  | 8   |
| Outdoor Units-   | 9   |
| Remote Control-  | 9   |
| SPECIFICATIONS-  | 10  |
| Product Specifications-  | 10  |
| Capacities and selection data-   | 14  |
| 9-12K Operation Characteristics curve-   | 18  |
| 18-24kK Operation Characteristics curve-   | 18  |
| 36K Operation Characteristics curve-   | 19  |
| 9-12K Capacity Variation Ratio According to Temperature-                                     | 20  |
| 18-24 K Capacity Variation Ratio According to Temperature-                                   | 20  |
| 36K Capacity Variation Ratio According to Temperature-                                       | 21  |
| 9-12K Noise Curve-   | 21  |
| 18-24K Noise Curve-  | 22  |
| 36K Noise Curve-   | 22  |
| Cooling Data Sheet in Rated Frequency-   | 23  |
| Heating Data Sheet in Rated Frequency-   | 23  |
| 18-24K Indoor Unit Dimensions-   | 25  |
| 9-12K Outdoor Unit Dimensions-   | 26  |
| 18-24K Outdoor Unit Dimensions-  | 27  |
| 36K Outdoor Unit Dimensions-   | 27  |
| OPERATION-   | 28  |
| Remote Control Button Identification-  | 28  |
| Remote Control Description-  | 29  |
| 9-24k Sequence of Operation-   | 33  |
| 36k Sequence of Operation-   | 42  |
| 9-12K Refrigerant System Diagram-  | 45  |
| 18-24K Refrigerant System Diagram-   | 45  |
| 36K Refrigerant System Diagram-  | 46  |
| INSTALLATION-  | 47  |
| Installation Tools-  | 48  |
| Installation Parts Checklist-  | 51  |
| Selection of Installation Location-  | 51  |
| Installation of Indoor Unit-   | 53  |
| Leak Check, Evacuation, and Charging (Triple Evacuation)-                                    | 60  |
| Checklist and Operation Test-  | 62  |
| Check Unit following Installation-   | 62  |
| Test Operation-  | 62  |
| REMOVAL-   | 63  |
| Indoor Unit-   | 63  |
| Outdoor Unit-  | 68  |
| WIRED CONTROLLER-  | 72  |
| Display-   | 72  |
| Buttons-   | 74  |
| Operation Instructions-  | 75  |
| Installation Instructions-   | 93  |
| R-410A SEALED SYSTEM REPAIR-   | 98  |
| Service Valves Appearance-   | 98  |
| Pumping Down-  | 99  |
| Gas Charging (After Repair)-   | 100 |
| COMPONENTS TESTING -   | 101 |
| Resistance Table of Ambient Temperature Sensor for Indoor and Outdoor Units (15k $\Omega$ )- | 101 |
| Resistance Table of Ambient Temperature Sensor for Indoor and Outdoor Units (20k $\Omega$ )- | 102 |
| Resistance Table of Ambient Temperature Sensor for Indoor and Outdoor Units (50k $\Omega$ )- | 103 |
| 9-12k Indoor Unit Printed Circuit Board Identification-                                      | 104 |
| 18-24k Indoor Unit Printed Circuit Board Identification-                                     | 105 |
| 36k Indoor Unit Printed Circuit Board Identification-  | 106 |
| 9-12k Outdoor Unit Printed Circuit Board Identification-                                     | 107 |
| 18-24k Outdoor Unit Printed Circuit Board Identification-                                    | 108 |
| 36k Outdoor Unit Printed Circuit Board Identification-                                       | 109 |
| TROUBLESHOOTING-   | 110 |
| Diagnostic Codes-  | 110 |
| Malfunction of Temperature Sensor F1, F2-  | 118 |
| 9-12k Malfunction of blocked Protection of IDU Fan Motor H6-                                 | 119 |
| 18-36k Malfunction of blocked Protection of IDU Fan Motor H6-                                | 120 |
| Malfunction of Protection of Jumper Cap C5-  | 121 |

---

# TABLE OF CONTENTS

|  |     |
|--|-----|
| Malfunction of IDU Fan Motor U8-   | 122 |
| Malfunction of Communication E6 -  | 124 |
| Malfunction of Power Supply from Indoor to Outdoor Unit-                   | 125 |
| Malfunction of Detecting Plate (WIFI) JF-                                  | 126 |
| Indoor fan does not rotate and there is no Feedback-                       | 127 |
| Temperature sensor malfunction-  | 128 |
| Malfunction diagnosis of startup failure-                                  | 129 |
| Diagnosis of losing synchronism for compressor -                           | 130 |
| 9-12k, 36k Diagnosis of overload and discharge malfunction-                | 131 |
| 18-24k Diagnosis of overload and discharge malfunction-                    | 132 |
| Capacity Charging malfunction - Outdoor unit-                              | 133 |
| 9-24k PM protection, phase current overcurrent -                           | 134 |
| 36k IPM Protection, Out-of-Step Fault, Compressor Phase Overcurrent-       | 135 |
| High temperature and Overload Protection Diagnosis-                        | 136 |
| PFC (Correction Power Factor) Outdoor Unit Malfunction-                    | 137 |
| Communication malfunction: (following AP1 for outdoor unit control board)- | 138 |
| High-pressure Protection-  | 139 |
| Troubleshooting for Malfunction without Active Error Code-                 | 140 |
| WIRING DIAGRAMS-   | 143 |
| 9-12K Indoor Unit Wiring Diagram -   | 143 |
| 18-24k Indoor Unit Wiring Diagram-   | 144 |
| 36K Indoor Unit Wiring Diagrams -  | 145 |
| 18-24k Outdoor Unit Wiring Diagrams-                                       | 147 |
| 36k Outdoor Unit Wiring Diagrams-  | 147 |
| PARTS CATALOG-   | 148 |
| 9K Indoor Unit -   | 148 |
| 12k Indoor Unit-   | 150 |
| 18K Indoor Unit-   | 152 |
| 24K Indoor Unit-   | 154 |
| 36K Indoor Unit-   | 156 |
| 9K Outdoor Unit-   | 158 |
| 12k Outdoor Unit-  | 160 |
| 18k Outdoor Unit-  | 162 |
| 24k Outdoor Unit-  | 164 |
| 36k Outdoor Unit-  | 166 |
| APPENDIX-  | 168 |
| Appendix 1: Reference Sheet of Celsius and Fahrenheit-                     | 168 |
| Appendix 2: Configuration of Connection Pipe-                              | 168 |
| Appendix 3: Pipe Expanding Method-   | 169 |
| LIMITED WARRANTY-  | 170 |
| FRIEDRICH AUTHORIZED PARTS DEPOTS-   | 171 |

# INTRODUCTION

## Important Safety Information

The information in this manual is intended for use by a qualified technician who is familiar with the safety procedures required for installation and repair, and who is equipped with the proper tools and test instruments required to service this product.

Installation or repairs made by unqualified persons can result in subjecting the unqualified person making such repairs as well as the persons being served by the equipment to hazards resulting in injury or electrical shock which can be serious or even fatal.

Safety warnings have been placed throughout this manual to alert you to potential hazards that may be encountered. If you install or perform service on equipment, it is your responsibility to read and obey these warnings to guard against any bodily injury or property damage which may result to you or others.

**Your safety and the safety of others is very important.**

We have provided many important safety messages in this manual and on your appliance. Always read and obey all safety messages.

This is a safety Alert symbol.  
This symbol alerts you to potential hazards that can kill or hurt you and others.



All safety messages will follow the safety alert symbol with the word "WARNING" or "CAUTION". These words mean:

 **WARNING** Indicates a hazard which, if not avoided, can result in severe personal injury or death and damage to product or other property.

**CAUTION** Indicates a hazard which, if not avoided, can result in personal injury and damage to product or other property.

All safety messages will tell you what the potential hazard is, tell you how to reduce the chance of injury, and tell you what will happen if the instructions are not followed.

**NOTICE** Indicates property damage can occur if instructions are not followed.

 **WARNING**

|   |  |
|---|--|
|  | <p style="text-align: center;"><b>Refrigeration system under high pressure</b></p> <p>Do not puncture, heat, expose to flame or incinerate.</p> <p>Only certified refrigeration technicians should service this equipment.</p> <p>R410A systems operate at higher pressures than R22 equipment. Appropriate safe service and handling practices must be used.</p> <p>Only use gauge sets designed for use with R410A.</p> <p>Do not use standard R22 gauge sets.</p> |
|---|--|



# INTRODUCTION

## Important Safety Information

### CAUTION

DO NOT OPERATE EQUIPMENT DURING ACTIVE STAGES OF CONSTRUCTION

To ensure proper operation, Friedrich requires that all equipment is not operated during active construction phases. This includes active stages of completing framing, drywalling, spackling, sanding, painting, flooring, and moulding in the equipment's designated conditioning space. The use of this equipment during construction could result in premature failure of the components and/or system and is in violation of our standard warranty guidelines. The operation of newly installed equipment during construction will accelerate the commencement and/or termination of the warranty period.

### WARNING

Please read this manual thoroughly prior to equipment installation or operation. It is the installer's responsibility to properly apply and install the equipment. Installation must be in conformance with the NFPA 70-2008 National Electric Code or current edition, International Mechanic code 2009 or current edition and any other applicable local or national codes.

### WARNING

Refrigeration system under high pressure. Do not puncture, heat, expose to flame or incinerate. Only certified refrigeration technicians should service this equipment. R410A systems operate at higher pressures than R22 equipment. Appropriate safe service and handling practices must be used. Only use gauge sets designed for use with R410A. Do not use R22 gauge sets. Failure to do so can result in property damage, personal injury, or death.

### WARNING

#### Electrical shock hazard.

Turn OFF electric power before service or installation. Unit must be properly grounded. Unit must have correct fuse or circuit breaker protection. Unit's supply circuit must have the correct wire conductor size. All electrical connections and wiring must be installed by a qualified electrician and conform to the National Electrical Code and all local codes which have jurisdiction. Failure to do so can result in property damage, personal injury and/or death.



### Your safety and the safety of others are very important.

We have provided many important safety messages in this manual and on your appliance. Always read and obey all safety messages.

This is the safety Alert symbol.

This symbol alerts you to potential

hazards that can kill or hurt you and others.

All safety messages will follow the safety alert symbol with the word "WARNING" or "CAUTION".

These words mean:



Indicates a hazard which, if not avoided, can result in severe personal injury or death and damage to product or other property.

### WARNING

Indicates a hazard which, if not avoided, can result in personal injury and damage to product or other property. All safety messages will tell you how to reduce the chance of injury, and tell you what will happen if the instructions

### CAUTION



Indicates property damage can occur if instructions are not followed.

### NOTICE

---

# INTRODUCTION

## Personal injury or death hazards

|                         |  <b>WARNING</b>                                   |  <b>AVERTISSEMENT</b>   |  <b>ADVERTENCIA</b>                                      |
|-------------------------|--|--|---|
| <b>SAFETY<br/>FIRST</b> | Do not remove, disable or bypass this unit's safety devices. Doing so may cause fire, Doing so may cause fire, injuries, or death. | Ne pas supprimer, désactiver ou contourner cette l'unité des dispositifs de sécurité, faire vous risqueriez de provoquer le feu, les blessures ou la mort. | No eliminar, desactivar o pasar por alto los dispositivos de seguridad de la unidad. Si lo hace podría producirse fuego, lesiones o muerte. |

### ELECTRICAL HAZARDS:

- Shutdown and/or disconnect all electrical power to the unit before performing inspections, maintenance, or service.
- Make sure to follow proper lockout/tag out procedures.
- Always work in the company of a qualified assistant if possible.
- Capacitors, even when disconnected from the electrical power source, retain an electrical charge potential capable of causing electric shock or electrocution. Wait a few minutes after shutdown to allow the capacitors to discharge the stored energy.
- Handle, discharge, and test capacitors according to safe, established, standards, and approved procedures.
- Extreme care, proper judgment, and safety procedures must be exercised if it becomes necessary to test or troubleshoot equipment with the power turned on to the unit.
- Do not spray water on the air conditioning unit while the power is on.
- Electrical component malfunction caused by water could result in electric shock or other electrically unsafe conditions when the power is restored and the unit is turned on, even after the exterior is dry.
- Use air conditioner on a single dedicated circuit within the specified amperage rating.
- Ensure the unit that the unit is properly grounded.
- Do not cut or modify the power supply cord or remove the ground prong of the plug.
- Never operate the unit on an extension cord.
- Follow all safety precautions and use approved protective safety equipment such as: gloves, goggles, and clothing. Ensure that properly insulated tools, and testing equipment are used as well to protect against equipment damage and reduce the risk of injury.
- Failure to follow proper safety procedures and these warnings can result in serious injury or possibly death.

# INTRODUCTION

## Model identification guide

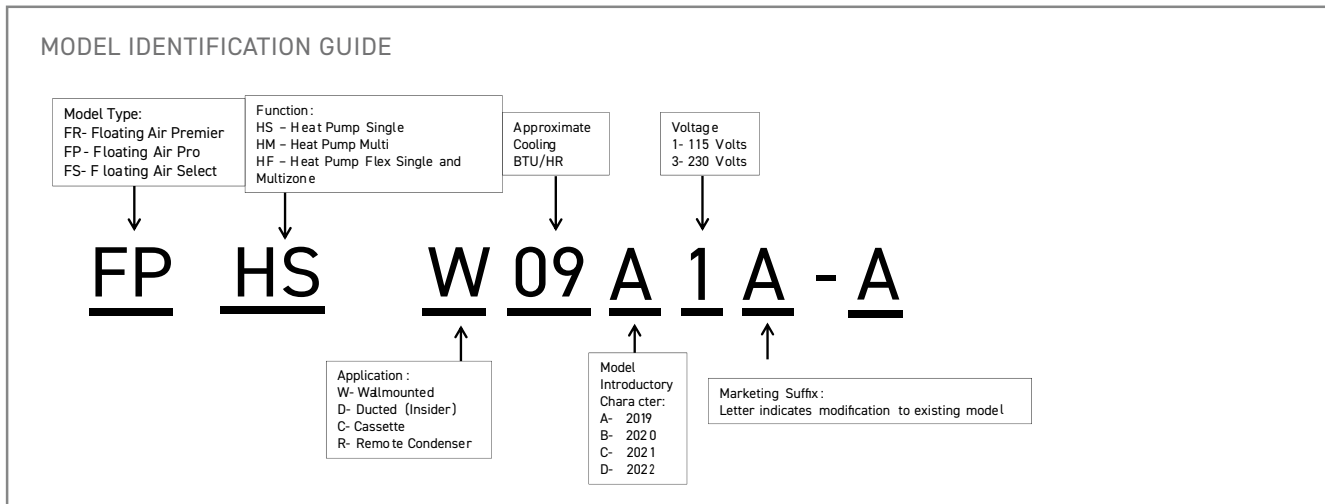
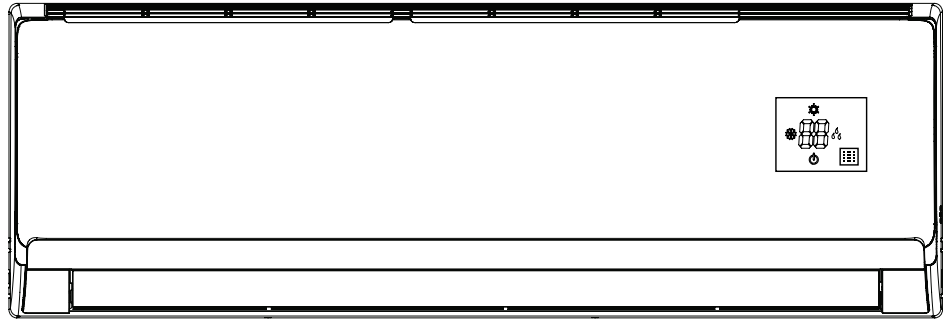

**Figure 101**  
Model Identification Guide

---

# INTRODUCTION

FSHSW09A1A  
FSHSW12A1A



FSHSW18A3A  
FSHSW24A3A

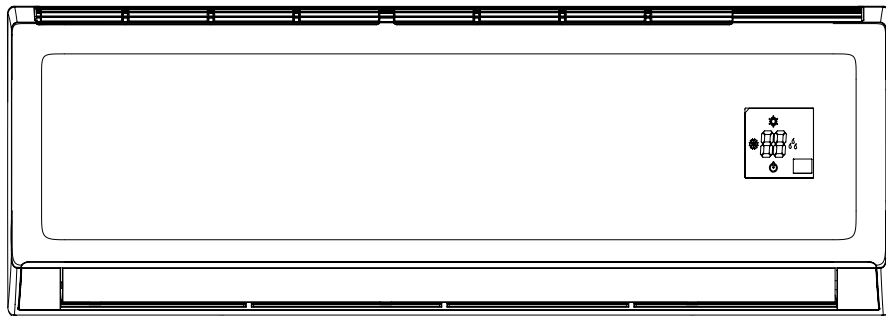

FSHSW36A3A

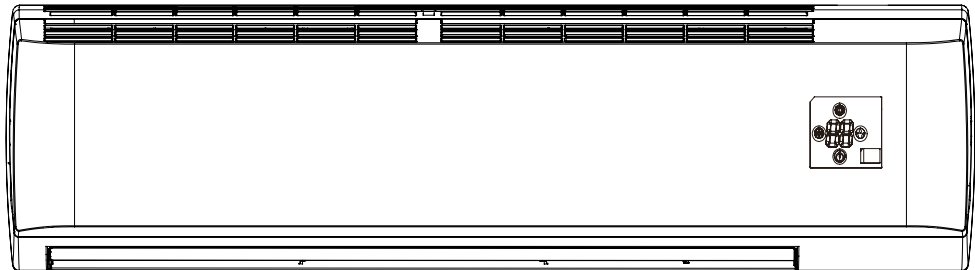
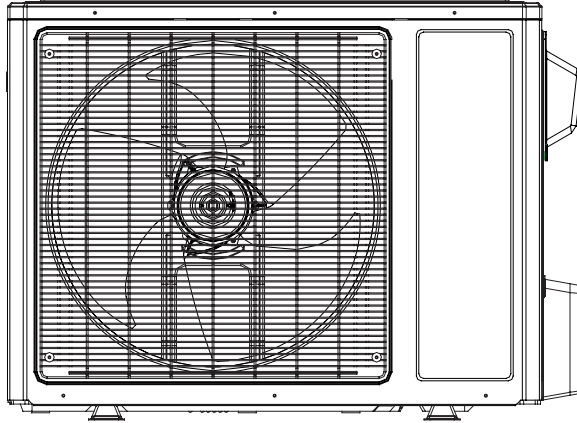

Figure 102  
Indoor Units

---

# INTRODUCTION

FHSR09A1A  
FHSR12A1A  
FHSR18A3A  
FHSR24A3A  
FHSR36A3A



**Figure 103**  
Outdoor Units

FHSW09A1A  
FHSW12A1A  
FHSW18A3A  
FHSW24A3A  
FHSW36A3A



**Figure 104**  
Remote Control

# SPECIFICATIONS

| Friedrich Indoor Model Number                 |                 | Unit     | FSHSW09A1A      | FSHSW12A1A      | FSHSW18A3A      | FSHSW24A3A                   | FSHSW36A3A                   |
|---|-----------------|----------|-----------------|-----------------|-----------------|------------------------------|------------------------------|
| Friedrich Outdoor Model Number                |                 |          | FHSR09A1A       | FHSR12A1A       | FHSR18A3A       | FHSR24A3A                    | FHSR36A3A                    |
| Friedrich Indoor UPC code                     |                 |          | 724587438710    | 724587438727    | 724587438734    | 724587438741                 | 724587438758                 |
| Friedrich Outdoor UPC code                    |                 |          | 724587438765    | 724587438772    | 724587438789    | 724587438796                 | 724587438802                 |
| Product Code                                  |                 |          | CB425008200     | CB425007900     | CB425007400     | CB425007700                  | CB432008100                  |
| Power Supply                                  | Rated Voltage   | V        | 115             | 115             | 208/230         | 208/230                      | 208/230                      |
|   | Rated Frequency | Hz       | 60              | 60              | 60              | 60                           | 60                           |
|   | Phases          | --       | 1               | 1               | 1               | 1                            | 1                            |
| Power Supply Mode                             |                 |          | Outdoor         | Outdoor         | Outdoor         | Outdoor                      | Outdoor                      |
| Cross-sectional Area of Power Cable Conductor |                 | AWG      | AWG12           | AWG12           | AWG14           | AWG14                        | AWG12                        |
| Recommended Power Cable(Core)                 |                 | N        | 3               | 3               | 3               | 3                            | 3                            |
| Min/Max. Voltage                              |                 | V        | 103/127         | 103/127         | 187/253         | 187/253                      | 187/253                      |
| Cooling Capacity                              |                 | W        | 2638            | 3517            | 5275            | 6450                         | 9850                         |
| Cooling Capacity                              |                 | Btu/h    | 9000            | 12000           | 18000           | 22000                        | 33600                        |
| Min. Cooling Capacity                         |                 | W        | 810             | 1100            | 1000            | 2500                         | 2170                         |
| Min. Cooling Capacity                         |                 | Btu/h    | 2764            | 3753            | 3412            | 8600                         | 7404.04                      |
| Max. Cooling Capacity                         |                 | W        | 2850            | 3664            | 6000            | 7034                         | 10550                        |
| Max. Cooling Capacity                         |                 | Btu/h    | 9724            | 12500           | 20472           | 24000                        | 35996.6                      |
| Heating Capacity                              |                 | W        | 2784            | 3810            | 5803            | 7034                         | 10140                        |
| Heating Capacity                              |                 | Btu/h    | 9500            | 13000           | 19800           | 24000                        | 34600                        |
| Min. Heating Capacity                         |                 | W        | 610             | 1000            | 1000            | 2500                         | 4390                         |
| Min. Heating Capacity                         |                 | Btu/h    | 2081            | 3412            | 3412            | 8600                         | 14978.68                     |
| Max. Heating Capacity                         |                 | W        | 3600            | 4400            | 6400            | 7600                         | 10550                        |
| Max. Heating Capacity                         |                 | Btu/h    | 12283           | 15013           | 21837           | 26000                        | 35996.6                      |
| Cooling Power Input                           |                 | W        | 900             | 1194            | 1820            | 2010                         | 4100                         |
| Min. Cooling Power Input                      |                 | W        | 350             | 380             | 80              | 600                          | 450                          |
| Max. Cooling Power Input                      |                 | W        | 1100            | 1300            | 2350            | 2700                         | 4300                         |
| Heating Power Input                           |                 | W        | 870             | 1250            | 2090            | 2130                         | 3800                         |
| Min. Heating Power Input                      |                 | W        | 280             | 350             | 220             | 650                          | 560                          |
| Max. Heating Power Input                      |                 | W        | 1250            | 1350            | 2350            | 2750                         | 4300                         |
| Cooling Current                               |                 | A        | 10.87           | 13              | 8.1             | 8.92                         | 17                           |
| Heating Current                               |                 | A        | 10.36           | 13.5            | 8.5             | 9.45                         | 16.5                         |
| Rated Input                                   |                 | W        | 1270            | 1350            | 2350            | 2750                         | 4300                         |
| Rated Current                                 |                 | A        | 12.66           | 13.5            | 12              | 11.98                        | 20                           |
| Rated Heating Current                         |                 | A        | 10.65           | 13.8            | 13              | 12.2                         | 20                           |
| Max. Over Current Protection                  |                 | A        | 25              | 30              | 25              | 25                           | 40                           |
| Min. Current [MCA]                            |                 | A        | 17              | 20              | 16              | 16                           | 24                           |
| Starting Current                              |                 | A        | 6               | 8               | /               | 5                            | 2                            |
| EER   |                 | W/W      | 2.93            | 2.95            | 2.9             | 3.21                         | 2.4                          |
| EER   |                 | Btu/h)/w | 10              | 10.05           | 9.89            | 10.95                        | 8.2                          |
| COP   |                 | W/W      | 3.2             | 3.05            | 2.78            | 3.3                          | 2.67                         |
| COP   |                 | Btu/h)/w | 10.92           | 10.4            | 9.47            | 11.3                         | 9.11                         |
| SEER  |                 |          | 18              | 18              | 18              | 18                           | 18                           |
| HSPF  |                 |          | 9               | 9               | 9               | 10                           | 9                            |
| Air Flow Volume                               |                 | m3/h     | 540/490/410/290 | 680/540/410/330 | 850/750/650/500 | 1200/1050/900/750            | 1500/1300/1100/950           |
| Air Flow Volume                               |                 | CFM      | 318/288/241/171 | 400/318/241/194 | 500/441/383/294 | 706.2/617.925/529.65/441.375 | 882.75/765.05/647.35/559.075 |

Figure 201

## Product Specifications

# SPECIFICATIONS

| Friedrich Indoor Model Number  |                                | Unit   | FSHSW09A1A               | FSHSW12A1A               | FSHSW18A3A               | FSHSW24A3A               | FSHSW36A3A               |
|--------------------------------|--------------------------------|--------|--------------------------|--------------------------|--------------------------|--------------------------|--------------------------|
| Friedrich Outdoor Model Number |                                |        | FHSR09A1A                | FHSR12A1A                | FHSR18A3A                | FHSR24A3A                | FHSR36A3A                |
| Dehumidifying Volume           |                                | L/h    | 0.8                      | 1.4                      | 1.8                      | 2                        | 3.5                      |
| Dehumidifying Volume           |                                | PINT/D | 1.69                     | 2.96                     | 3.8                      | 4.23                     | 7.4                      |
| Application Area               |                                | sq ft  | 130-194                  | 172-258                  | 248-366                  | 248-366                  | 495-764                  |
| Indoor unit                    | Fan Type                       | --     | Cross-flow               | Cross-flow               | Cross-flow               | Cross-flow               | Cross-flow               |
|                                | Fan Diameter Length(D×L)       | inch   | 3 6/7×22 5/6             | 3 6/7×25                 | /                        | 4 1/4×32 7/10            | 4 1/4 × 20 4/7           |
|                                | Cooling Speed                  | r/min  | 1350/1200/1050/750       | 1350/1200/1000/800       | 1350/1200/1050/900       | 1300/1150/1000/850       | 1400/1250/1000/800       |
|                                | Heating Speed                  | r/min  | 1350/1200/1050/850       | 1350/1200/1000/900       | 1300/1200/1100/900       | 1300/1150/1000/850       | 1400/1250/1050/850       |
|                                | Fan Motor Power Output         | W      | 20                       | 20                       | 35                       | 30                       | 70                       |
|                                | Fan Motor RLA                  | A      | 0.24                     | 0.25                     | 0.37                     | 0.32                     | 0.4                      |
|                                | Fan Motor Capacitor            | µF     | 4                        | 4                        | 2.5                      | 3                        | 0                        |
|                                | Evaporator Form                | --     | Aluminum Fin-copper Tube | Aluminum Fin-copper Tube | Aluminum Fin-copper Tube | Aluminum Fin-copper Tube | Aluminum Fin-copper Tube |
|                                | Evaporator Pipe Diameter       | inch   | 0.197                    | 0.197                    | /                        | /                        | 2/7                      |
|                                | Evaporator Row-fin Gap         | inch   | 2-1/18                   | 2-1/18                   | /                        | /                        | 2-1/18                   |
|                                | Evaporator Coil Length (L×D×W) | inch   | 23×7/8×10 8/16           | 25×7/8×12 1/16           | /                        | 33 1/4×1×13 1/2          | 42 2/7×1×15              |
|                                | Swing Motor Model              | --     | MP24AA                   | MP24BA                   | MP35CJ                   | MP35CJ                   | MP24BA                   |
|                                | Swing Motor Power Output       | W      | 1.5                      | 1.5                      | 2.5                      | 2.5                      | 1.5                      |
|                                | Fuse Current                   | A      | 3.15                     | 3.15                     | 3.15                     | 3.15                     | 3.15                     |
|                                | Set Temperature Range          | *F     | 61-86                    | 61-86                    | 61-86                    | 61-86                    | 61-86                    |
|                                | Sound Pressure Level           | dB (A) | 43/38/34/28              | 43/39/35/29              | 47/44/41/35              | 49/46/42/36              | 54/49/44/37              |
|                                | Sound Power Level              | dB (A) | 53/48/44/28              | 53/49/45/39              | 57/54/51/45              | 63/59/56/52              | 64/59/54/47              |
|                                | Dimension (W×H×D)              | inch   | 31.102×10.827×7.874      | 33.268×11.378×8.228      | 38.2×11.8×8.8            | 42.441×12.795×9.685      | 53.15×12.835×9.961       |
| Net Weight                     | lb                             | 20.9   | 23.2                     | 30.9                     | 37.485                   | 41.895                   |                          |
| Gross Weight                   | lb                             | 25.4   | 27.6                     | 37.5                     | 45.202                   | 51.818                   |                          |

Figure 202  
Product Specifications

# SPECIFICATIONS

| Friedrich Indoor Model Number                                 |   | Unit  | FSHSW09A1A                           | FSHSW12A1A                           | FSHSW18A3A                       | FSHSW24A3A                       | FSHSW36A3A                        |
|---|---|-------|--------------------------------------|--------------------------------------|----------------------------------|----------------------------------|-----------------------------------|
| Friedrich Outdoor Model Number                                |   |       | FSHSR09A1A                           | FSHSR12A1A                           | FSHSR18A3A                       | FSHSR24A3A                       | FSHSR36A3A                        |
| Outdoor Unit  | Compressor Manufacturer   |       | ZHUHAI LANDA COM-PRESSOR CO.,LTD     | ZHUHAI LANDA COM-PRESSOR CO.,LTD     | ZHUHAI LANDA COM-PRESSOR CO.,LTD | ZHUHAI LANDA COM-PRESSOR CO.,LTD | ZHUHAI LANDA COM-PRESSOR CO., LTD |
|   | Compressor Model  |       | QXA-A091zE190                        | QXA-A091zE190                        | QXA-B141zF030A                   | QXA-B141zF030A                   | QXAS-D32ZX090A                    |
|   | Compressor Oil  |       | FVC68D or RB 68EP                    | FVC68D or RB 68EP                    | RB68EP                           | RB68EP                           | RB68EP or equivalent              |
|   | Compressor Type   |       | Rotary                               | Rotary                               | Rotary                           | Rotary                           | Rotary                            |
|   | Compressor LRA  | A     | 40                                   | 40                                   | 25                               | 25                               | 67                                |
|   | Compressor RLA  | A     | 12.62                                | 15.23                                | 12.08                            | 12.18                            | 17.5                              |
|   | Compressor Power Input  | W     | 980                                  | 980                                  | 1440                             | 1440                             | 4150±3%                           |
|   | Compressor Overload Protector                                   |       | 1NT11L-6233 or KSD115 or HPC115/95U1 | 1NT11L-6233 or KSD115 or HPC115/95U1 | /                                | /                                | 1NT11L-6233                       |
|   | Fan Type  |       | Axial-flow                           | Axial-flow                           | Axial-flow                       | Axial-flow                       | Axial-flow                        |
|   | Fan Diameter  | inch  | 15.748                               | 15.748                               | /                                | 20                               | 21.654                            |
|   | Fan Motor Speed   | rpm   | 850                                  | 900                                  | 800                              | 800                              | 890                               |
|   | Fan Motor Power Output  | W     | 30                                   | 30                                   | 60                               | 60                               | 170                               |
|   | Fan Motor RLA   | A     | 0.24                                 | 0.23                                 | 0.52                             | 0.4                              | 0.73                              |
|   | Outdoor Unit Air Flow Volume                                    | m3/h  | 1800                                 | 1800                                 | 3200                             | 3200                             | 4400                              |
|   | Condenser Form  |       | Aluminum Fin-copper Tube             | Aluminum Fin-copper Tube             | Aluminum Fin-copper Tube         | Aluminum Fin-copper Tube         | Aluminum Fin-copper Tube          |
|   | Condenser Pipe diameter   | inch  | 0.276                                | 0.276                                | /                                | /                                | 3/8                               |
|   | Condenser Rows-fin Gap  | mm    | 1-1.4                                | 2-1.4                                | 1-1.4                            | 2-1.4                            | 2-1.4                             |
|   | Condenser Rows-fin Gap  | inch  | 1-1/18                               | 2-1/18                               | /                                | /                                | 2-1/18                            |
|   | Condenser Coil Length (L×D×W)                                   | inch  | 29 3/4×3/4×20                        | 28×1 1/2×20                          | /                                | /                                | 37×1 3/4×30                       |
|   | Permissible Excessive Operating Pressure for the Discharge Side | MPa   | 4.3                                  | 4.3                                  | 4.3                              | 4.3                              | 4.3                               |
| Permissible Excessive Operating Pressure for the Suction Side | MPa   | 2.5   | 2.5                                  | 2.5                                  | 2.5                              | 2.5                              |                                   |
| Maximum Allowable Pressure                                    | MPa   | 4.3   | 4.3                                  | 4.3                                  | 4.3                              | 4.3                              |                                   |
| Cooling Operation Ambient Temperature Range                   | *F  | 0-115 | 0-115                                | 00115                                | 0-115                            | 0-115                            |                                   |



# SPECIFICATIONS

| Friedrich Indoor Model Number  |  | Unit   | FSHSW09A1A               | FSHSW12A1A               | FSHSW18A3A               | FSHSW24A3A               | FSHSW36A3A               |
|--------------------------------|--|--------|--------------------------|--------------------------|--------------------------|--------------------------|--------------------------|
| Friedrich Outdoor Model Number |  |        | FSHSR09A1A               | FSHSR12A1A               | FSHSR18A3A               | FSHSR24A3A               | FSHSR36A3A               |
| Outdoor Unit                   | Heating Operation Ambient Temperature Range              | *F     | -4~75                    | -4~75                    | -13~75                   | -13~75                   | -4~75                    |
|                                | Throttling Method  |        | Electron expansion valve | Electron expansion valve | Electron expansion valve | Electron expansion valve | Electron expansion valve |
|                                | Defrosting Method  |        | Automatic Defrosting     | Automatic Defrosting     | Automatic Defrosting     | /                        | Automatic Defrosting     |
|                                | Climate Type   |        | T1                       | T1                       | T1                       | T1                       | T1                       |
|                                | Climate Zone   |        | Temperate Zone           | Temperate Zone           | Temperate Zone           | Frigid Zone              | Temperate Zone           |
|                                | Isolation  |        | I                        | I                        | I                        | I                        | I                        |
|                                | Moisture Protection                                      |        | IPX4                     | IPX4                     | IPX4                     | IPX4                     | IPX4                     |
|                                | Sound Pressure Level                                     | dB (A) | 52                       | 53                       | 57                       | 58                       | 65                       |
|                                | Sound Power Level  | dB (A) | 62                       | 63                       | 67                       | 68                       | 75                       |
|                                | Dimension (W×H×D)  | inch   | 33.386×21.26×12.598      | 33.386×21.26×12.598      | 37.6×27.6×15.6           | 37.598×27.559×15.591     | 38.583×31.102×16.811     |
|                                | Net Weight   | lb     | 62.8                     | 67.3                     | 97                       | 103.635                  | 160.965                  |
|                                | Gross Weight   | lb     | 68.4                     | 72.8                     | 106.9                    | 113.558                  | 171.99                   |
|                                | Refrigerant  |        | R410A                    | R410A                    | R410A                    | R410A                    | R410A                    |
|                                | Refrigerant Charge                                       | oz     | 24.7                     | 31.8                     | 45.86                    | 56.4                     | 91.71                    |
|                                | Length   | ft     | 24.6                     | 24.6                     | 24.6                     | 24.6                     | 24.6                     |
|                                | Gas Additional Charge                                    | oz/ft. | 0.2                      | 0.2                      | 0.2                      | 0.538                    | 0.538                    |
|                                | Outer Diameter of Liquid Pipe(British System Allocation) | inch   | 1/4"                     | 1/4"                     | 1/4"                     | 1/4"                     | 1/4"                     |
|                                | Outer Diameter of Gas Pipe(British System Allocation)    | inch   | 3/8"                     | 3/8"                     | 1/2"                     | 5/8"                     | 5/8"                     |
|                                | Max Distance Height                                      | ft     | 32.8                     | 49.2                     | 65                       | 65.6                     | 32.8                     |
|                                | Max Distance Length                                      | ft     | 65.6                     | 98.4                     | 100                      | 100.1                    | 98.4                     |

---

# SPECIFICATIONS

## Capacities and selection data

### Capacity characteristic charts

The following charts show the characteristics of outdoor unit capacity, which corresponds with the operating ambient temperature of outdoor unit. This data is obtained with Free-Spin of the Condenser and not in a testing mode

Conditions:

- 1- Pipelength / height difference: 25 ft. (7.6m) / 0 ft. (0m)
- 2- Compressor at rated inverter frequency
- 3- Indoor fan speed at high fan speed
- 4- Capacity loss due to frost accumulation and defrost operation is not included.

# SPECIFICATIONS

## Capacities and selection data

### Cooling Template

| Indoor units(Btu) | Outdoor Air Temp. (°F DB) | Indoor Air Temp. °F DB / °F WB |       |       |         |       |       |         |       |       |             |             |             |             |             |             |             |             |             |
|-------------------|---------------------------|--------------------------------|-------|-------|---------|-------|-------|---------|-------|-------|-------------|-------------|-------------|-------------|-------------|-------------|-------------|-------------|-------------|
|                   |                           | 64 / 54                        |       |       | 70 / 60 |       |       | 75 / 83 |       |       | 80 / 67     |             |             | 85 / 71     |             |             | 90 / 73     |             |             |
|                   |                           | TC                             | SHC   | PI    | TC      | SHC   | PI    | TC      | SHC   | PI    | TC          | SHC         | PI          | TC          | SHC         | PI          | TC          | SHC         | PI          |
| FSHSW09A1A        | 14                        | 3.83                           | 2.81  | 0.60  | 4.55    | 3.34  | 0.63  | 4.86    | 3.57  | 0.65  | 5.22        | 3.84        | 0.67        | 5.40        | 3.97        | 0.68        | 4.95        | 3.64        | 0.68        |
|                   | 23                        | 4.19                           | 3.10  | 0.63  | 4.91    | 3.63  | 0.66  | 5.22    | 3.86  | 0.67  | 5.58        | 4.13        | 0.69        | 5.76        | 4.26        | 0.70        | 5.31        | 3.93        | 0.71        |
|                   | 32                        | 4.37                           | 3.25  | 0.65  | 5.09    | 3.79  | 0.68  | 5.40    | 4.02  | 0.70  | 5.76        | 4.29        | 0.72        | 5.94        | 4.43        | 0.73        | 5.49        | 4.09        | 0.74        |
|                   | 41                        | 4.91                           | 3.68  | 0.67  | 5.63    | 4.22  | 0.71  | 5.94    | 4.46  | 0.72  | 6.30        | 4.73        | 0.75        | 6.48        | 4.86        | 0.76        | 6.03        | 4.52        | 0.77        |
|                   | 50                        | 5.45                           | 4.11  | 0.70  | 6.17    | 4.65  | 0.74  | 6.48    | 4.89  | 0.75  | 6.84        | 5.16        | 0.77        | 7.02        | 5.30        | 0.78        | 6.57        | 4.96        | 0.79        |
|                   | 59                        | 5.90                           | 4.48  | 0.72  | 6.62    | 5.03  | 0.76  | 6.93    | 5.27  | 0.78  | 7.29        | 5.54        | 0.80        | 7.47        | 5.68        | 0.81        | 7.02        | 5.34        | 0.82        |
|                   | 67                        | 6.08                           | 4.65  | 0.75  | 6.80    | 5.20  | 0.79  | 7.11    | 5.44  | 0.80  | 7.47        | 5.71        | 0.83        | 7.65        | 5.85        | 0.84        | 7.20        | 5.51        | 0.85        |
|                   | 77                        | 7.97                           | 6.13  | 0.77  | 8.69    | 6.69  | 0.81  | 9.00    | 6.93  | 0.83  | 9.36        | 7.21        | 0.86        | 9.54        | 7.35        | 0.86        | 9.09        | 7.00        | 0.87        |
|                   | 87                        | 8.42                           | 6.52  | 0.80  | 9.14    | 7.08  | 0.84  | 9.45    | 7.32  | 0.86  | 9.81        | 7.60        | 0.88        | 9.99        | 7.74        | 0.89        | 9.54        | 7.39        | 0.90        |
|                   | 95                        | 7.61                           | 5.93  | 0.81  | 8.33    | 6.49  | 0.86  | 8.64    | 6.74  | 0.87  | <b>9.00</b> | <b>7.02</b> | <b>0.90</b> | <b>9.18</b> | <b>7.16</b> | <b>0.91</b> | <b>8.73</b> | <b>6.81</b> | <b>0.92</b> |
|                   | 104                       | 6.66                           | 5.23  | 0.89  | 7.38    | 5.79  | 0.94  | 7.74    | 6.08  | 0.96  | 8.10        | 6.36        | 0.99        | 8.28        | 6.50        | 1.00        | 7.83        | 6.15        | 1.01        |
|                   | 115                       | 6.300                          | 4.977 | 0.975 | 7.020   | 5.546 | 1.026 | 7.380   | 5.830 | 1.048 | 7.740       | 6.115       | 1.080       | 7.920       | 6.257       | 1.089       | 7.470       | 5.901       | 1.098       |

### Heating Template

| Indoor units(Btu) | Outdoor Air |       | Indoor Air Temp. °F DB |       |       |       |             |             |       |       |       |      |
|-------------------|-------------|-------|------------------------|-------|-------|-------|-------------|-------------|-------|-------|-------|------|
|                   | °F DB       | °F WB | 60                     |       | 65    |       | 70          |             | 75    |       | 78    |      |
|                   |             |       | TC                     | PI    | TC    | PI    | TC          | PI          | TC    | PI    | TC    | PI   |
| FSHSW09A1A        | -15         | -17   | 3.61                   | 0.67  | 3.71  | 0.68  | 3.99        | 0.70        | 4.09  | 0.71  | 4.13  | 0.71 |
|                   | -5          | -7    | 4.18                   | 0.68  | 4.28  | 0.69  | 4.56        | 0.71        | 4.66  | 0.73  | 4.70  | 0.73 |
|                   | 5           | 3     | 5.13                   | 0.71  | 5.23  | 0.72  | 5.51        | 0.74        | 5.61  | 0.75  | 5.65  | 0.76 |
|                   | 10          | 8     | 5.32                   | 0.73  | 5.42  | 0.73  | 5.70        | 0.76        | 5.80  | 0.77  | 5.84  | 0.77 |
|                   | 14          | 12    | 5.80                   | 0.74  | 5.89  | 0.75  | 6.18        | 0.77        | 6.27  | 0.79  | 6.32  | 0.79 |
|                   | 23          | 19    | 7.32                   | 0.77  | 7.41  | 0.78  | 7.70        | 0.80        | 7.79  | 0.82  | 7.84  | 0.82 |
|                   | 32          | 28    | 7.98                   | 0.79  | 8.08  | 0.79  | 8.36        | 0.82        | 8.46  | 0.84  | 8.50  | 0.84 |
|                   | 41          | 37    | 8.65                   | 0.80  | 8.74  | 0.81  | 9.03        | 0.84        | 9.12  | 0.85  | 9.17  | 0.86 |
|                   | 47          | 43    | 9.12                   | 0.84  | 9.22  | 0.84  | <b>9.50</b> | <b>0.87</b> | 9.60  | 0.89  | 9.64  | 0.89 |
|                   | 50          | 47    | 9.22                   | 0.86  | 9.31  | 0.87  | 9.60        | 0.90        | 9.69  | 0.91  | 9.74  | 0.92 |
|                   | 59          | 50    | 9.31                   | 0.89  | 9.41  | 0.90  | 9.69        | 0.92        | 9.79  | 0.94  | 9.83  | 0.95 |
|                   | 68          | 59    | 9.93                   | 0.94  | 10.02 | 0.95  | 10.31       | 0.98        | 10.40 | 1.00  | 10.45 | 1.00 |
| 75                | 65          | 10.17 | 0.97                   | 10.26 | 0.98  | 10.55 | 1.01        | 10.64       | 1.03  | 10.69 | 1.03  |      |

### Cooling Template

| Indoor units(Btu) | Outdoor Air Temp. (°F DB) | Indoor Air Temp. °F DB / °F WB |      |      |         |      |      |         |      |      |              |             |             |         |       |      |         |      |      |
|-------------------|---------------------------|--------------------------------|------|------|---------|------|------|---------|------|------|--------------|-------------|-------------|---------|-------|------|---------|------|------|
|                   |                           | 64 / 54                        |      |      | 70 / 60 |      |      | 75 / 83 |      |      | 80 / 67      |             |             | 85 / 71 |       |      | 90 / 73 |      |      |
|                   |                           | TC                             | SHC  | PI   | TC      | SHC  | PI   | TC      | SHC  | PI   | TC           | SHC         | PI          | TC      | SHC   | PI   | TC      | SHC  | PI   |
| FSHSW12A1A        | 14                        | 5.10                           | 3.75 | 0.80 | 6.06    | 4.45 | 0.84 | 6.48    | 4.76 | 0.86 | 6.96         | 5.12        | 0.88        | 7.20    | 5.29  | 0.90 | 6.60    | 4.85 | 0.91 |
|                   | 23                        | 5.58                           | 4.13 | 0.83 | 6.54    | 4.84 | 0.87 | 6.96    | 5.15 | 0.89 | 7.44         | 5.51        | 0.92        | 7.68    | 5.68  | 0.93 | 7.08    | 5.24 | 0.94 |
|                   | 32                        | 5.82                           | 4.34 | 0.86 | 6.78    | 5.05 | 0.91 | 7.20    | 5.36 | 0.93 | 7.68         | 5.72        | 0.96        | 7.92    | 5.90  | 0.97 | 7.32    | 5.45 | 0.98 |
|                   | 41                        | 6.54                           | 4.91 | 0.89 | 7.50    | 5.63 | 0.94 | 7.92    | 5.94 | 0.96 | 8.40         | 6.30        | 0.99        | 8.64    | 6.48  | 1.00 | 8.04    | 6.03 | 1.01 |
|                   | 50                        | 7.26                           | 5.48 | 0.93 | 8.22    | 6.21 | 0.98 | 8.64    | 6.52 | 1.00 | 9.12         | 6.89        | 1.03        | 9.36    | 7.07  | 1.04 | 8.76    | 6.61 | 1.05 |
|                   | 59                        | 7.86                           | 5.97 | 0.96 | 8.82    | 6.70 | 1.01 | 9.24    | 7.02 | 1.03 | 9.72         | 7.39        | 1.06        | 9.96    | 7.57  | 1.07 | 9.36    | 7.11 | 1.09 |
|                   | 67                        | 8.10                           | 6.20 | 0.99 | 9.06    | 6.93 | 1.04 | 9.48    | 7.25 | 1.07 | 9.96         | 7.62        | 1.10        | 10.20   | 7.80  | 1.11 | 9.60    | 7.34 | 1.12 |
|                   | 77                        | 10.62                          | 8.18 | 1.02 | 11.58   | 8.92 | 1.08 | 12.00   | 9.24 | 1.10 | 12.48        | 9.61        | 1.13        | 12.72   | 9.79  | 1.15 | 12.12   | 9.33 | 1.16 |
|                   | 87                        | 11.22                          | 8.70 | 1.06 | 12.18   | 9.44 | 1.11 | 12.60   | 9.77 | 1.14 | 13.08        | 10.14       | 1.17        | 13.32   | 10.32 | 1.18 | 12.72   | 9.86 | 1.19 |
|                   | 95                        | 10.14                          | 7.91 | 1.08 | 11.10   | 8.66 | 1.13 | 11.52   | 8.99 | 1.16 | <b>12.00</b> | <b>9.36</b> | <b>1.19</b> | 12.24   | 9.55  | 1.21 | 11.64   | 9.08 | 1.22 |
|                   | 104                       | 8.88                           | 6.97 | 1.19 | 9.84    | 7.72 | 1.25 | 10.32   | 8.10 | 1.27 | 10.80        | 8.48        | 1.31        | 11.04   | 8.67  | 1.33 | 10.44   | 8.20 | 1.34 |
|                   | 115                       | 8.40                           | 6.64 | 1.29 | 9.36    | 7.39 | 1.36 | 9.84    | 7.77 | 1.39 | 10.32        | 8.15        | 1.43        | 10.56   | 8.34  | 1.44 | 9.96    | 7.87 | 1.46 |

### Heating Template

| Indoor units(Btu) | Outdoor Air |       | Indoor Air Temp. °F DB |       |       |       |              |             |       |       |       |      |
|-------------------|-------------|-------|------------------------|-------|-------|-------|--------------|-------------|-------|-------|-------|------|
|                   | °F DB       | °F WB | 60                     |       | 65    |       | 70           |             | 75    |       | 78    |      |
|                   |             |       | TC                     | PI    | TC    | PI    | TC           | PI          | TC    | PI    | TC    | PI   |
| FSHSW12A1A        | -15         | -17   | 4.94                   | 0.96  | 5.07  | 0.97  | 5.46         | 1.00        | 5.59  | 1.02  | 5.66  | 1.03 |
|                   | -5          | -7    | 5.72                   | 0.98  | 5.85  | 0.99  | 6.24         | 1.02        | 6.37  | 1.04  | 6.44  | 1.05 |
|                   | 5           | 3     | 7.02                   | 1.02  | 7.15  | 1.03  | 7.54         | 1.06        | 7.67  | 1.08  | 7.74  | 1.09 |
|                   | 10          | 8     | 7.28                   | 1.04  | 7.41  | 1.05  | 7.80         | 1.09        | 7.93  | 1.11  | 8.00  | 1.11 |
|                   | 14          | 12    | 7.93                   | 1.06  | 8.06  | 1.07  | 8.45         | 1.11        | 8.58  | 1.13  | 8.65  | 1.13 |
|                   | 23          | 19    | 10.01                  | 1.11  | 10.14 | 1.12  | 10.53        | 1.15        | 10.66 | 1.18  | 10.73 | 1.18 |
|                   | 32          | 28    | 10.92                  | 1.13  | 11.05 | 1.14  | 11.44        | 1.18        | 11.57 | 1.20  | 11.64 | 1.21 |
|                   | 41          | 37    | 11.83                  | 1.15  | 11.96 | 1.16  | 12.35        | 1.20        | 12.48 | 1.22  | 12.55 | 1.23 |
|                   | 47          | 43    | 12.48                  | 1.20  | 12.61 | 1.21  | <b>13.00</b> | <b>1.25</b> | 13.13 | 1.28  | 13.20 | 1.28 |
|                   | 50          | 47    | 12.61                  | 1.24  | 12.74 | 1.25  | 13.13        | 1.29        | 13.26 | 1.31  | 13.33 | 1.32 |
|                   | 59          | 50    | 12.74                  | 1.27  | 12.87 | 1.29  | 13.26        | 1.33        | 13.39 | 1.35  | 13.46 | 1.36 |
|                   | 68          | 59    | 13.59                  | 1.35  | 13.72 | 1.36  | 14.11        | 1.41        | 14.24 | 1.44  | 14.30 | 1.44 |
| 75                | 65          | 13.91 | 1.39                   | 14.04 | 1.41  | 14.43 | 1.45         | 14.56       | 1.48  | 14.63 | 1.49  |      |

# SPECIFICATIONS

## Capacities and selection data

### Cooling Template

| Indoor units(Btu) | Outdoor Air Temp. (°F DB) | Indoor Air Temp. °F DB / °F WB |       |      |         |       |      |        |       |      |              |              |             |         |       |      |         |       |      |
|-------------------|---------------------------|--------------------------------|-------|------|---------|-------|------|--------|-------|------|--------------|--------------|-------------|---------|-------|------|---------|-------|------|
|                   |                           | 64 / 54                        |       |      | 70 / 60 |       |      | 75/ 83 |       |      | 80 / 67      |              |             | 85 / 71 |       |      | 90 / 73 |       |      |
|                   |                           | TC                             | SHC   | PI   | TC      | SHC   | PI   | TC     | SHC   | PI   | TC           | SHC          | PI          | TC      | SHC   | PI   | TC      | SHC   | PI   |
| FSHSW18A3A        | 14                        | 9.82                           | 6.23  | 1.20 | 10.17   | 7.32  | 1.23 | 10.74  | 7.74  | 1.25 | 12.13        | 8.73         | 1.27        | 12.49   | 9.37  | 1.30 | 13.67   | 10.25 | 1.32 |
|                   | 23                        | 10.85                          | 6.88  | 1.22 | 11.50   | 8.28  | 1.26 | 12.31  | 8.86  | 1.27 | 14.10        | 10.15        | 1.30        | 14.52   | 10.89 | 1.32 | 15.51   | 11.63 | 1.34 |
|                   | 32                        | 12.03                          | 8.86  | 1.23 | 12.93   | 9.31  | 1.29 | 13.83  | 9.95  | 1.30 | 15.84        | 11.41        | 1.33        | 16.32   | 12.24 | 1.35 | 17.43   | 13.07 | 1.37 |
|                   | 41                        | 12.52                          | 9.03  | 1.32 | 13.46   | 9.69  | 1.43 | 14.40  | 10.37 | 1.44 | 16.50        | 11.88        | 1.47        | 17.00   | 12.75 | 1.50 | 18.15   | 13.61 | 1.52 |
|                   | 50                        | 13.00                          | 9.38  | 1.36 | 14.03   | 10.10 | 1.46 | 15.00  | 10.80 | 1.47 | 17.19        | 12.37        | 1.50        | 17.70   | 13.28 | 1.53 | 18.91   | 14.18 | 1.55 |
|                   | 59                        | 14.53                          | 10.53 | 1.37 | 15.28   | 11.00 | 1.48 | 16.35  | 11.77 | 1.50 | 17.91        | 12.89        | 1.53        | 18.44   | 13.83 | 1.56 | 20.61   | 15.46 | 1.58 |
|                   | 67                        | 17.00                          | 12.12 | 1.56 | 17.92   | 12.90 | 1.65 | 19.04  | 13.71 | 1.67 | 20.35        | 14.65        | 1.70        | 20.96   | 15.72 | 1.74 | 23.33   | 17.50 | 1.76 |
|                   | 77                        | 16.23                          | 11.65 | 1.60 | 17.18   | 12.37 | 1.69 | 18.28  | 13.16 | 1.70 | 19.56        | 14.09        | 1.74        | 20.15   | 15.11 | 1.77 | 22.46   | 16.85 | 1.79 |
|                   | 87                        | 15.02                          | 11.08 | 1.63 | 16.16   | 11.64 | 1.72 | 17.24  | 12.41 | 1.74 | 18.81        | 13.54        | 1.77        | 19.38   | 14.53 | 1.81 | 21.53   | 16.15 | 1.83 |
|                   | 95                        | 14.31                          | 10.56 | 1.65 | 15.44   | 11.12 | 1.75 | 15.77  | 11.35 | 1.77 | <b>18.09</b> | <b>13.02</b> | <b>1.81</b> | 18.63   | 13.97 | 1.84 | 20.82   | 15.62 | 1.86 |
|                   | 104                       | 14.00                          | 10.02 | 1.70 | 15.04   | 11.28 | 1.78 | 15.37  | 11.53 | 1.80 | 17.18        | 12.37        | 1.84        | 17.70   | 13.27 | 1.88 | 19.69   | 14.77 | 1.89 |
|                   | 115                       | 13.52                          | 10.23 | 1.77 | 14.45   | 10.84 | 1.89 | 15.00  | 11.25 | 1.91 | 16.15        | 12.11        | 1.95        | 16.63   | 12.48 | 1.99 | 19.16   | 14.37 | 2.01 |

### Heating Template

| Indoor units(Btu) | Outdoor Air |       | Indoor Air Temp. °F DB |      |       |      |              |             |       |      |       |      |
|-------------------|-------------|-------|------------------------|------|-------|------|--------------|-------------|-------|------|-------|------|
|                   | °F DB       | °F WB | 60                     |      | 65    |      | 70           |             | 75    |      | 78    |      |
|                   |             |       | TC                     | PI   | TC    | PI   | TC           | PI          | TC    | PI   | TC    | PI   |
| FSHSW18A3A        | -15         | -17   | 6.98                   | 1.62 | 6.75  | 1.65 | 6.56         | 1.70        | 6.39  | 1.78 | 6.13  | 1.81 |
|                   | -5          | -7    | 8.75                   | 1.70 | 8.60  | 1.76 | 8.51         | 1.82        | 8.42  | 1.86 | 8.23  | 1.90 |
|                   | 5           | 3     | 10.33                  | 1.73 | 10.13 | 1.80 | 10.01        | 1.86        | 9.91  | 1.91 | 9.80  | 1.93 |
|                   | 10          | 8     | 11.85                  | 1.80 | 11.60 | 1.86 | 11.43        | 1.91        | 11.28 | 1.95 | 11.23 | 1.98 |
|                   | 14          | 12    | 12.96                  | 1.83 | 12.75 | 1.90 | 12.52        | 1.94        | 12.31 | 1.98 | 12.11 | 2.01 |
|                   | 23          | 19    | 14.94                  | 1.86 | 14.74 | 1.92 | 14.46        | 1.96        | 14.02 | 2.00 | 13.88 | 2.04 |
|                   | 32          | 28    | 16.77                  | 1.90 | 16.48 | 1.96 | 16.16        | 2.00        | 15.67 | 2.04 | 15.51 | 2.08 |
|                   | 41          | 37.00 | 18.63                  | 1.94 | 18.46 | 2.00 | 18.10        | 2.04        | 17.56 | 2.08 | 17.38 | 2.12 |
|                   | 47          | 43.00 | 20.80                  | 1.97 | 20.60 | 2.04 | <b>20.20</b> | <b>2.08</b> | 19.59 | 2.12 | 19.39 | 2.16 |
|                   | 50          | 47.00 | 21.22                  | 1.99 | 21.02 | 2.06 | 20.60        | 2.10        | 19.98 | 2.14 | 19.78 | 2.18 |
|                   | 59          | 50    | 21.67                  | 2.01 | 21.44 | 2.08 | 21.02        | 2.12        | 20.38 | 2.16 | 20.17 | 2.20 |
|                   | 68          | 59    | 18.45                  | 1.71 | 18.22 | 1.77 | 17.86        | 1.80        | 17.33 | 1.84 | 17.15 | 1.87 |
|                   | 75          | 65    | 18.70                  | 1.75 | 18.58 | 1.80 | 18.22        | 1.84        | 17.67 | 1.87 | 17.49 | 1.91 |

### Cooling Template

| Indoor units(Btu) | Outdoor Air Temp. (°F DB) | Indoor Air Temp. °F DB / °F WB |       |      |         |       |      |        |       |      |              |              |             |         |       |      |         |       |      |
|-------------------|---------------------------|--------------------------------|-------|------|---------|-------|------|--------|-------|------|--------------|--------------|-------------|---------|-------|------|---------|-------|------|
|                   |                           | 64 / 54                        |       |      | 70 / 60 |       |      | 75/ 83 |       |      | 80 / 67      |              |             | 85 / 71 |       |      | 90 / 73 |       |      |
|                   |                           | TC                             | SHC   | PI   | TC      | SHC   | PI   | TC     | SHC   | PI   | TC           | SHC          | PI          | TC      | SHC   | PI   | TC      | SHC   | PI   |
| FSHSW24A3A        | 14                        | 7.48                           | 5.50  | 1.07 | 9.46    | 6.95  | 1.25 | 11.22  | 8.25  | 1.32 | 12.98        | 9.54         | 1.38        | 13.42   | 9.86  | 1.46 | 13.86   | 10.19 | 1.50 |
|                   | 23                        | 8.36                           | 6.19  | 1.13 | 9.90    | 7.33  | 1.32 | 11.66  | 8.63  | 1.39 | 13.42        | 9.93         | 1.46        | 14.08   | 10.42 | 1.48 | 14.74   | 10.91 | 1.56 |
|                   | 32                        | 9.02                           | 6.72  | 1.21 | 10.34   | 7.70  | 1.37 | 12.10  | 9.01  | 1.44 | 13.86        | 10.33        | 1.52        | 14.74   | 10.98 | 1.58 | 15.40   | 11.47 | 1.62 |
|                   | 41                        | 9.68                           | 7.26  | 1.27 | 11.66   | 8.75  | 1.41 | 13.42  | 10.07 | 1.48 | 15.18        | 11.39        | 1.56        | 15.84   | 11.88 | 1.64 | 16.50   | 12.38 | 1.68 |
|                   | 50                        | 10.78                          | 8.14  | 1.33 | 12.98   | 9.80  | 1.50 | 14.74  | 11.13 | 1.57 | 16.50        | 12.46        | 1.66        | 17.16   | 12.96 | 1.70 | 17.38   | 13.12 | 1.74 |
|                   | 59                        | 11.44                          | 8.69  | 1.42 | 13.86   | 10.53 | 1.55 | 15.62  | 11.87 | 1.63 | 17.38        | 13.21        | 1.72        | 17.60   | 13.38 | 1.76 | 18.04   | 13.71 | 1.77 |
|                   | 67                        | 12.32                          | 9.42  | 1.48 | 14.52   | 11.11 | 1.60 | 16.28  | 12.45 | 1.69 | 18.04        | 13.80        | 1.77        | 18.26   | 13.97 | 1.81 | 18.92   | 14.47 | 1.83 |
|                   | 77                        | 14.96                          | 11.52 | 1.54 | 18.48   | 14.23 | 1.62 | 20.24  | 15.58 | 1.70 | 22.00        | 16.94        | 1.79        | 22.22   | 17.11 | 1.85 | 22.66   | 17.45 | 1.87 |
|                   | 87                        | 15.84                          | 12.28 | 1.66 | 20.02   | 15.52 | 1.67 | 21.78  | 16.88 | 1.76 | 23.54        | 18.24        | 1.85        | 22.66   | 17.56 | 1.89 | 23.10   | 17.90 | 1.93 |
|                   | 95                        | 13.42                          | 10.47 | 1.76 | 18.48   | 14.41 | 1.76 | 20.24  | 15.79 | 1.85 | <b>22.00</b> | <b>17.16</b> | <b>1.95</b> | 23.32   | 18.19 | 2.01 | 23.98   | 18.70 | 2.05 |
|                   | 104                       | 12.98                          | 10.19 | 1.85 | 16.06   | 12.61 | 1.92 | 17.82  | 13.99 | 2.02 | 19.58        | 15.37        | 2.13        | 21.78   | 17.10 | 2.18 | 22.22   | 17.44 | 2.24 |
|                   | 115                       | 10.56                          | 8.34  | 1.99 | 14.74   | 11.64 | 2.04 | 16.50  | 13.04 | 2.15 | 18.26        | 14.43        | 2.26        | 20.02   | 15.82 | 2.34 | 20.24   | 15.99 | 2.36 |

### Heating Template

| Indoor units(Btu) | Outdoor Air |       | Indoor Air Temp. °F DB |      |       |      |              |             |       |      |       |      |
|-------------------|-------------|-------|------------------------|------|-------|------|--------------|-------------|-------|------|-------|------|
|                   | °F DB       | °F WB | 60                     |      | 65    |      | 70           |             | 75    |      | 78    |      |
|                   |             |       | TC                     | PI   | TC    | PI   | TC           | PI          | TC    | PI   | TC    | PI   |
| FSHSW24A3A        | -15         | -17   | 8.88                   | 1.56 | 9.36  | 1.59 | 10.32        | 1.66        | 10.80 | 1.69 | 11.28 | 1.72 |
|                   | -5          | -7    | 10.08                  | 1.59 | 10.56 | 1.62 | 11.52        | 1.69        | 12.00 | 1.73 | 12.48 | 1.76 |
|                   | 5           | 3     | 12.48                  | 1.66 | 12.96 | 1.69 | 13.92        | 1.76        | 14.40 | 1.80 | 14.88 | 1.83 |
|                   | 10          | 8     | 12.96                  | 1.69 | 13.44 | 1.73 | 14.40        | 1.80        | 14.88 | 1.83 | 15.36 | 1.87 |
|                   | 14          | 12    | 14.56                  | 1.73 | 15.04 | 1.76 | 16.00        | 1.83        | 16.48 | 1.87 | 16.96 | 1.91 |
|                   | 23          | 19    | 17.76                  | 1.80 | 18.24 | 1.83 | 19.20        | 1.91        | 19.68 | 1.95 | 20.16 | 1.99 |
|                   | 32          | 28    | 19.68                  | 1.83 | 20.16 | 1.87 | 21.12        | 1.95        | 21.60 | 1.99 | 22.08 | 2.03 |
|                   | 41          | 37    | 21.36                  | 1.87 | 21.84 | 1.91 | 22.80        | 1.99        | 23.28 | 2.03 | 23.76 | 2.07 |
|                   | 47          | 43    | 22.56                  | 1.95 | 23.04 | 1.99 | <b>24.00</b> | <b>2.07</b> | 24.48 | 2.11 | 24.96 | 2.15 |
|                   | 50          | 47    | 22.80                  | 2.01 | 23.28 | 2.05 | 24.24        | 2.13        | 24.72 | 2.17 | 25.20 | 2.22 |
|                   | 59          | 50    | 23.04                  | 2.07 | 23.52 | 2.11 | 24.48        | 2.20        | 24.96 | 2.24 | 25.44 | 2.28 |
|                   | 68          | 59    | 24.48                  | 2.19 | 24.96 | 2.24 | 25.92        | 2.33        | 26.40 | 2.38 | 26.88 | 2.42 |
|                   | 75          | 65    | 25.20                  | 2.26 | 25.68 | 2.30 | 26.64        | 2.40        | 27.12 | 2.45 | 27.60 | 2.50 |

# SPECIFICATIONS

## Capacities and selection data

### Cooling Template

| Indoor units(Btu) | Outdoor Air Temp. (°F DB) | Indoor Air Temp. °F DB / °F WB |       |      |         |       |      |         |       |      |              |              |             |         |       |      |         |       |      |
|-------------------|---------------------------|--------------------------------|-------|------|---------|-------|------|---------|-------|------|--------------|--------------|-------------|---------|-------|------|---------|-------|------|
|                   |                           | 64 / 54                        |       |      | 70 / 60 |       |      | 75 / 83 |       |      | 80 / 67      |              |             | 85 / 71 |       |      | 90 / 73 |       |      |
|                   |                           | TC                             | SHC   | PI   | TC      | SHC   | PI   | TC      | SHC   | PI   | TC           | SHC          | PI          | TC      | SHC   | PI   | TC      | SHC   | PI   |
|                   |                           | kBtu/h                         | kW    |      | kBtu/h  | kW    |      | kBtu/h  | kW    |      | kBtu/h       | kW           |             | kBtu/h  | kW    |      | kBtu/h  | kW    |      |
| FHSW36A3A         | 14                        | 11.40                          | 8.40  | 2.01 | 14.40   | 10.60 | 2.34 | 17.10   | 12.60 | 2.46 | 19.80        | 14.60        | 2.59        | 20.50   | 15.10 | 2.74 | 21.20   | 15.60 | 2.81 |
|                   | 23                        | 12.80                          | 9.50  | 2.12 | 15.10   | 11.20 | 2.47 | 17.80   | 13.20 | 2.60 | 20.50        | 15.20        | 2.74        | 21.50   | 15.90 | 2.77 | 22.50   | 16.70 | 2.92 |
|                   | 32                        | 13.80                          | 10.30 | 2.26 | 15.80   | 11.80 | 2.57 | 18.50   | 13.80 | 2.70 | 21.20        | 15.80        | 2.85        | 22.50   | 16.80 | 2.96 | 23.50   | 17.50 | 3.03 |
|                   | 41                        | 14.80                          | 11.10 | 2.37 | 17.80   | 13.40 | 2.64 | 20.50   | 15.40 | 2.77 | 23.20        | 17.40        | 2.92        | 24.20   | 18.20 | 3.07 | 25.20   | 18.90 | 3.14 |
|                   | 50                        | 16.50                          | 12.50 | 2.48 | 19.80   | 14.90 | 2.80 | 22.50   | 17.00 | 2.95 | 25.20        | 19.00        | 3.10        | 26.20   | 19.80 | 3.18 | 26.50   | 20.00 | 3.25 |
|                   | 59                        | 17.50                          | 13.30 | 2.66 | 21.20   | 16.10 | 2.90 | 23.90   | 18.20 | 3.05 | 26.50        | 20.10        | 3.21        | 26.90   | 20.40 | 3.29 | 27.60   | 21.00 | 3.32 |
|                   | 67                        | 18.80                          | 14.40 | 2.77 | 22.20   | 17.00 | 3.00 | 24.90   | 19.00 | 3.16 | 27.60        | 21.10        | 3.32        | 27.90   | 21.30 | 3.39 | 28.90   | 22.10 | 3.43 |
|                   | 77                        | 22.80                          | 17.60 | 2.88 | 28.20   | 21.70 | 3.03 | 30.90   | 23.80 | 3.19 | 33.60        | 25.90        | 3.36        | 33.90   | 26.10 | 3.47 | 34.60   | 26.60 | 3.50 |
|                   | 87                        | 24.20                          | 18.80 | 3.10 | 30.60   | 23.70 | 3.13 | 33.30   | 25.80 | 3.29 | 36.00        | 27.90        | 3.47        | 34.60   | 26.80 | 3.54 | 35.30   | 27.40 | 3.61 |
|                   | 95                        | 20.50                          | 16.00 | 3.29 | 28.20   | 22.00 | 3.29 | 30.90   | 24.10 | 3.47 | <b>33.60</b> | <b>26.20</b> | <b>3.65</b> | 35.60   | 27.80 | 3.76 | 36.60   | 28.50 | 3.83 |
|                   | 104                       | 19.80                          | 15.50 | 3.47 | 24.50   | 19.20 | 3.59 | 27.20   | 21.40 | 3.78 | 29.90        | 23.50        | 3.98        | 33.30   | 26.10 | 4.09 | 33.90   | 26.60 | 4.20 |
|                   | 115                       | 16.10                          | 12.70 | 3.72 | 22.50   | 17.80 | 3.82 | 25.20   | 19.90 | 4.02 | 27.90        | 22.00        | 4.23        | 30.60   | 24.20 | 4.38 | 30.90   | 24.40 | 4.42 |

### Heating Template

| Indoor units(Btu) | Outdoor Air |       | Indoor Air Temp. °F DB |      |        |      |              |             |        |      |        |      |
|-------------------|-------------|-------|------------------------|------|--------|------|--------------|-------------|--------|------|--------|------|
|                   | °F DB       | °F WB | 60                     |      | 65     |      | 70           |             | 75     |      | 78     |      |
|                   |             |       | TC                     | PI   | TC     | PI   | TC           | PI          | TC     | PI   | TC     | PI   |
|                   |             |       | kBtu/h                 | kW   | kBtu/h | kW   | kBtu/h       | kW          | kBtu/h | kW   | kBtu/h | kW   |
| FHSW36A3A         | -15         | -17   | 12.80                  | 2.73 | 13.50  | 2.78 | 14.20        | 2.84        | 14.90  | 2.90 | 16.30  | 3.02 |
|                   | -5          | -7    | 14.50                  | 2.78 | 15.20  | 2.84 | 15.90        | 2.90        | 16.60  | 2.96 | 18.00  | 3.08 |
|                   | 5           | 3     | 18.00                  | 2.90 | 18.70  | 2.96 | 19.40        | 3.02        | 20.10  | 3.08 | 21.50  | 3.20 |
|                   | 10          | 8     | 18.70                  | 2.96 | 19.40  | 3.02 | 20.10        | 3.08        | 20.80  | 3.14 | 22.10  | 3.27 |
|                   | 14          | 12    | 21.00                  | 3.02 | 21.70  | 3.08 | 22.40        | 3.14        | 23.10  | 3.21 | 24.50  | 3.34 |
|                   | 23          | 19    | 25.60                  | 3.14 | 26.30  | 3.21 | 27.00        | 3.27        | 27.70  | 3.34 | 29.10  | 3.47 |
|                   | 32          | 28    | 28.40                  | 3.21 | 29.10  | 3.27 | 29.80        | 3.34        | 30.40  | 3.41 | 31.80  | 3.54 |
|                   | 41          | 37    | 30.80                  | 3.27 | 31.50  | 3.34 | 32.20        | 3.41        | 32.90  | 3.48 | 34.30  | 3.62 |
|                   | 47          | 43    | 32.50                  | 3.41 | 33.20  | 3.48 | <b>33.90</b> | <b>3.55</b> | 34.60  | 3.62 | 36.00  | 3.77 |
|                   | 50          | 47    | 32.90                  | 3.51 | 33.60  | 3.58 | 34.30        | 3.65        | 34.90  | 3.73 | 36.30  | 3.88 |
|                   | 59          | 50    | 33.20                  | 3.61 | 33.90  | 3.69 | 34.60        | 3.76        | 35.30  | 3.84 | 36.70  | 4.00 |
|                   | 68          | 59    | 35.30                  | 3.83 | 36.00  | 3.91 | 36.70        | 3.99        | 37.40  | 4.07 | 38.80  | 4.24 |
|                   | 75          | 65    | 36.30                  | 3.95 | 37.00  | 4.03 | 37.70        | 4.11        | 38.40  | 4.20 | 39.80  | 4.37 |

# SPECIFICATIONS

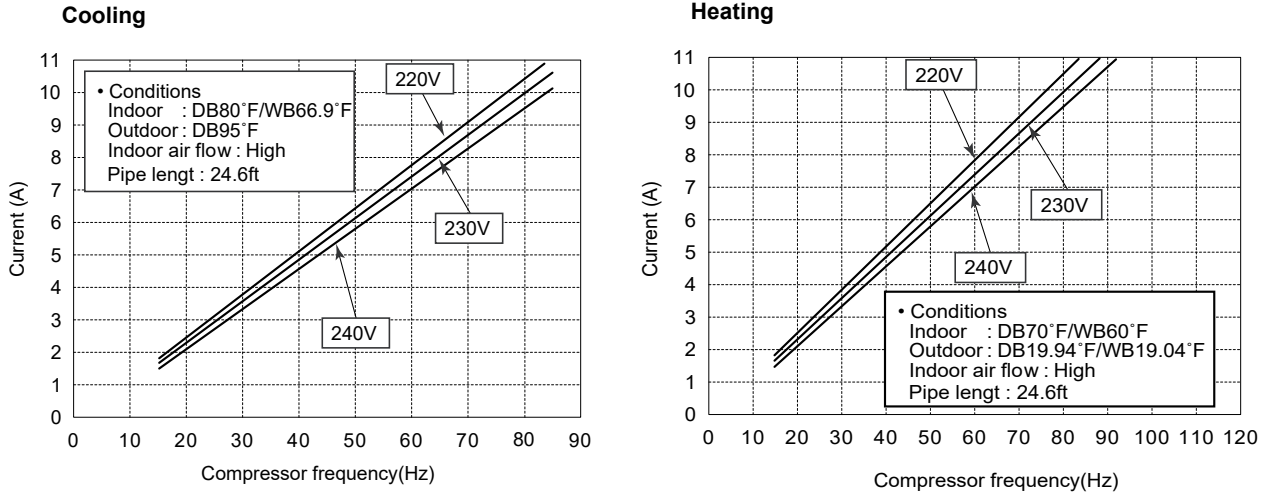

Figure 203  
9-12K Operation Characteristics curve

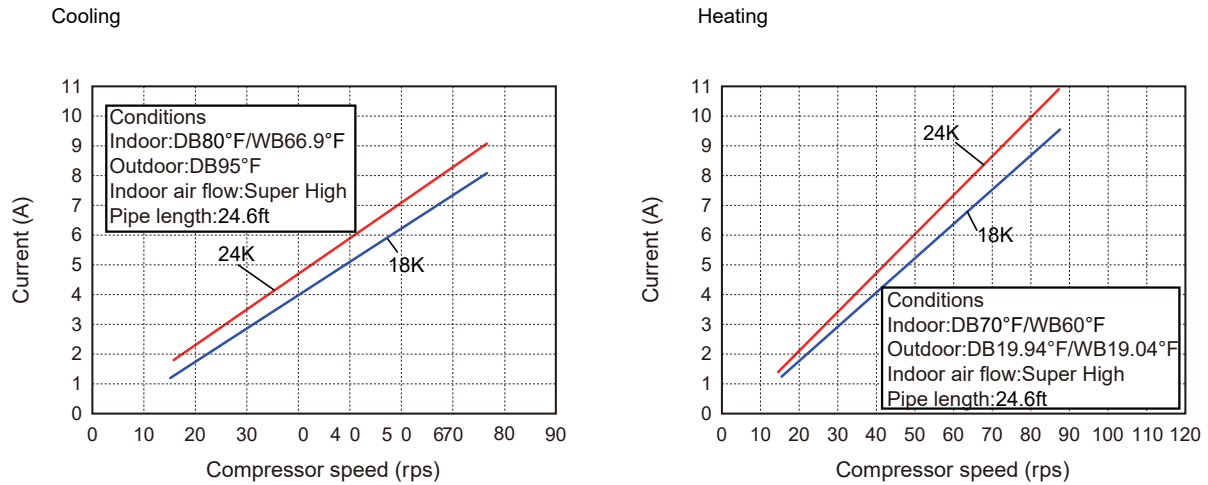
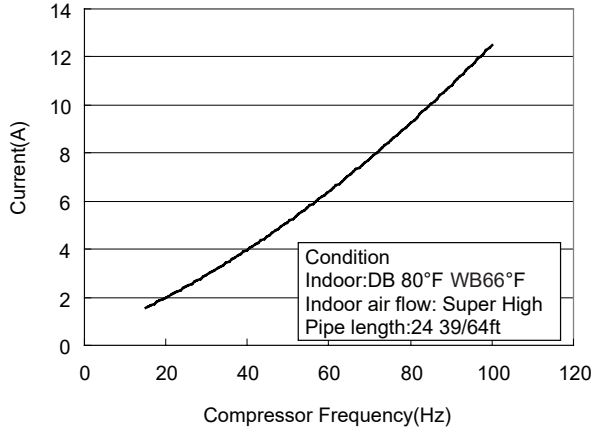

Figure 204  
18-24kK Operation Characteristics curve

# SPECIFICATIONS

24K

Cooling



Heating

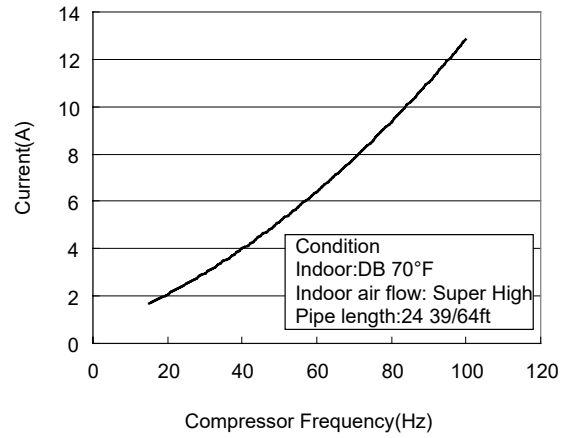
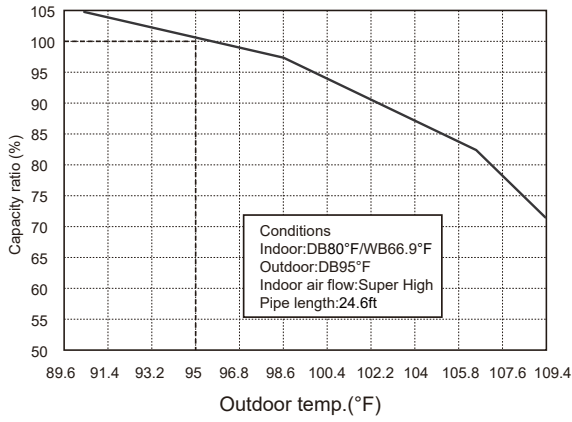

Figure 205

## 36K Operation Characteristics curve

# SPECIFICATIONS

## Cooling



## Heating

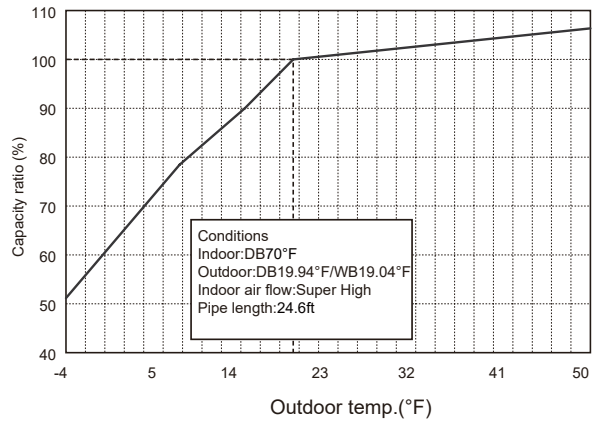
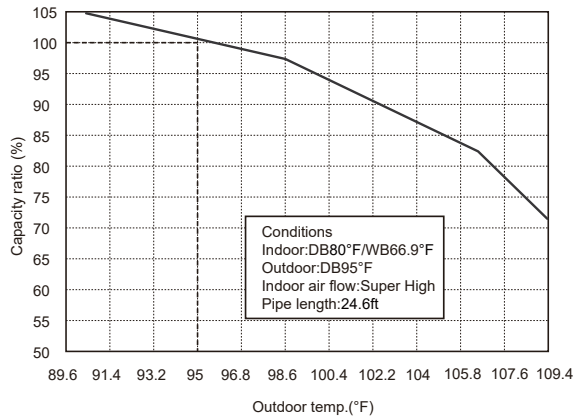

Figure 206

## 9-12K Capacity Variation Ratio According to Temperature

## Cooling



## Heating

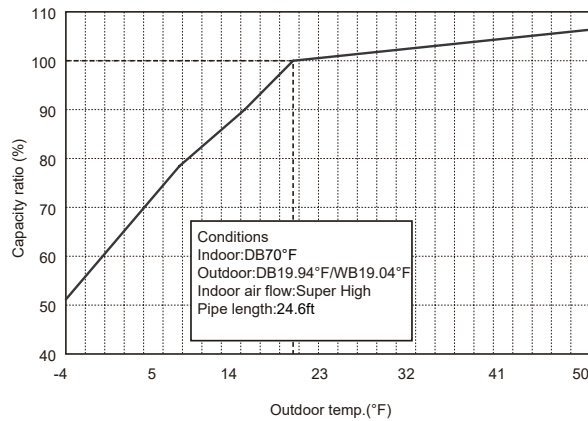
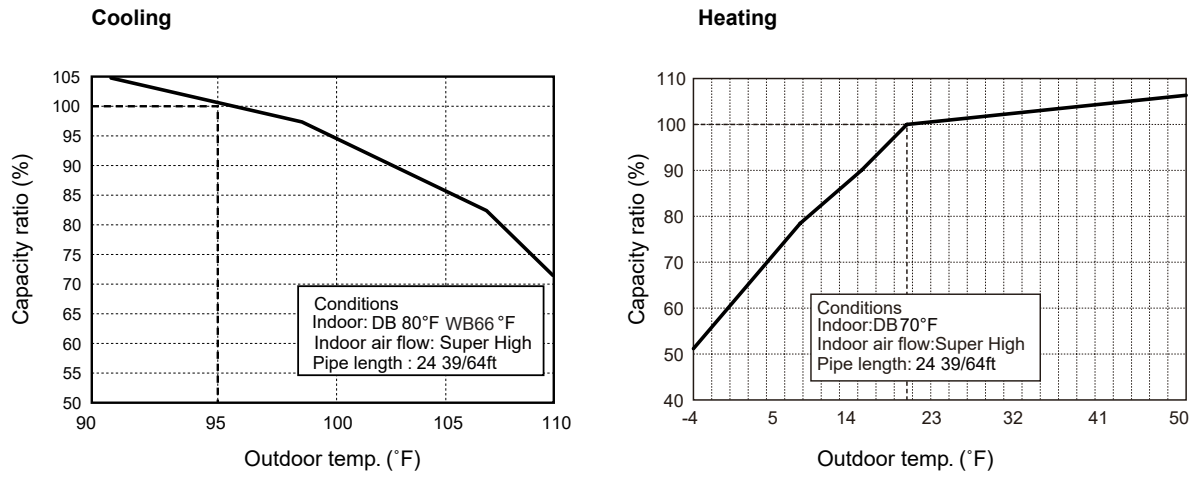

Figure 207

## 18-24 K Capacity Variation Ratio According to Temperature



# SPECIFICATIONS



**Figure 208**  
**36K Capacity Variation Ratio According to Temperature**

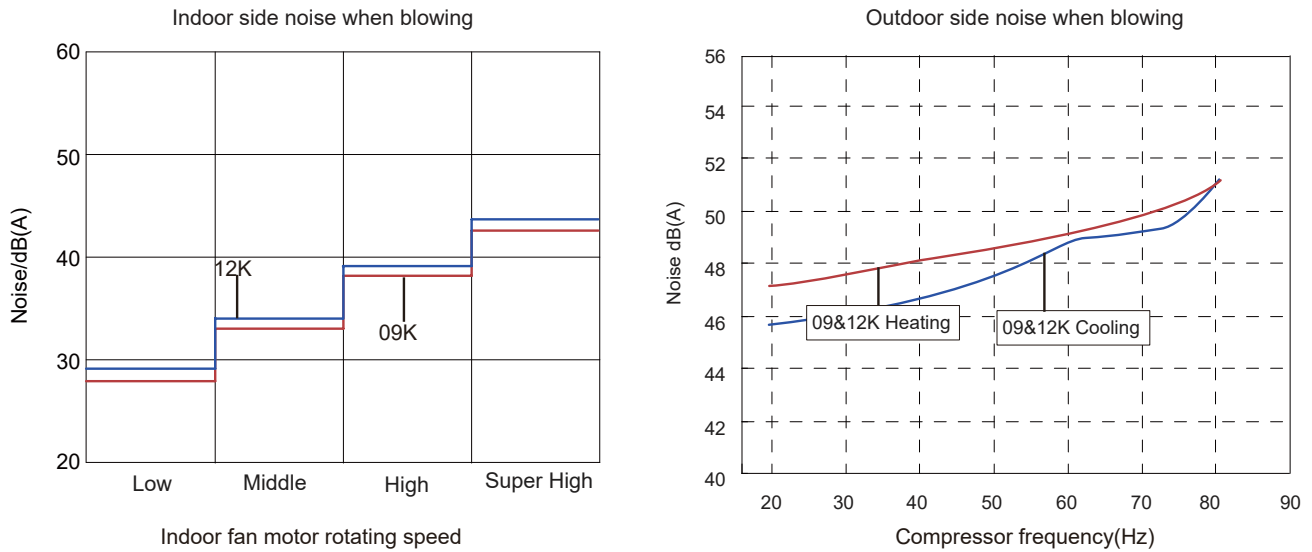

**Figure 209**  
**9-12K Noise Curve**

# SPECIFICATIONS

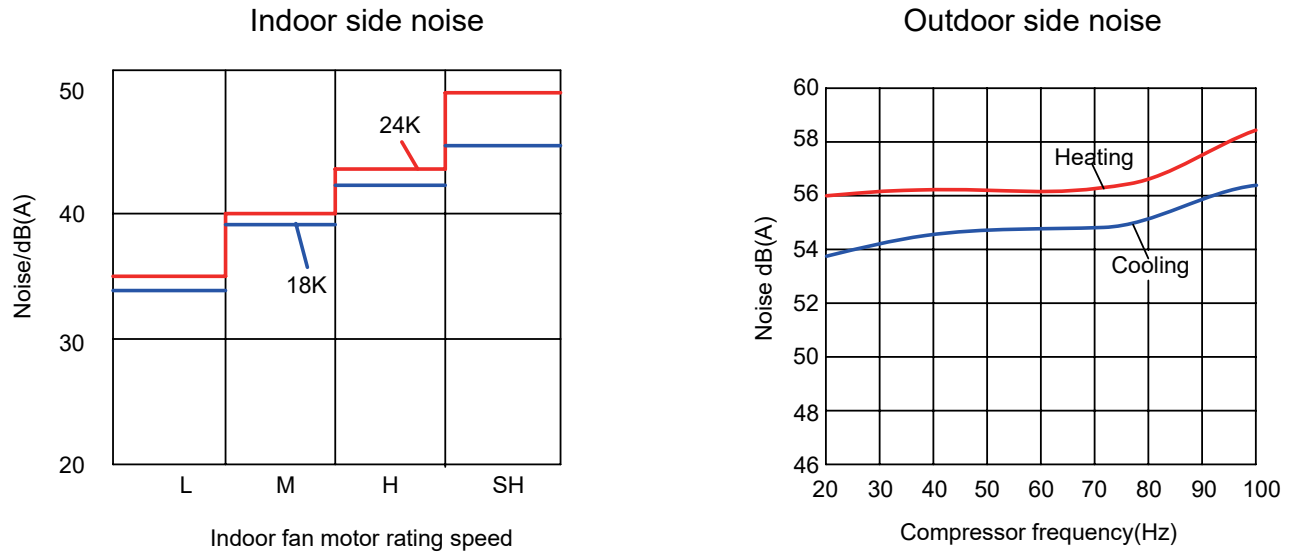

Figure 210  
18-24K Noise Curve

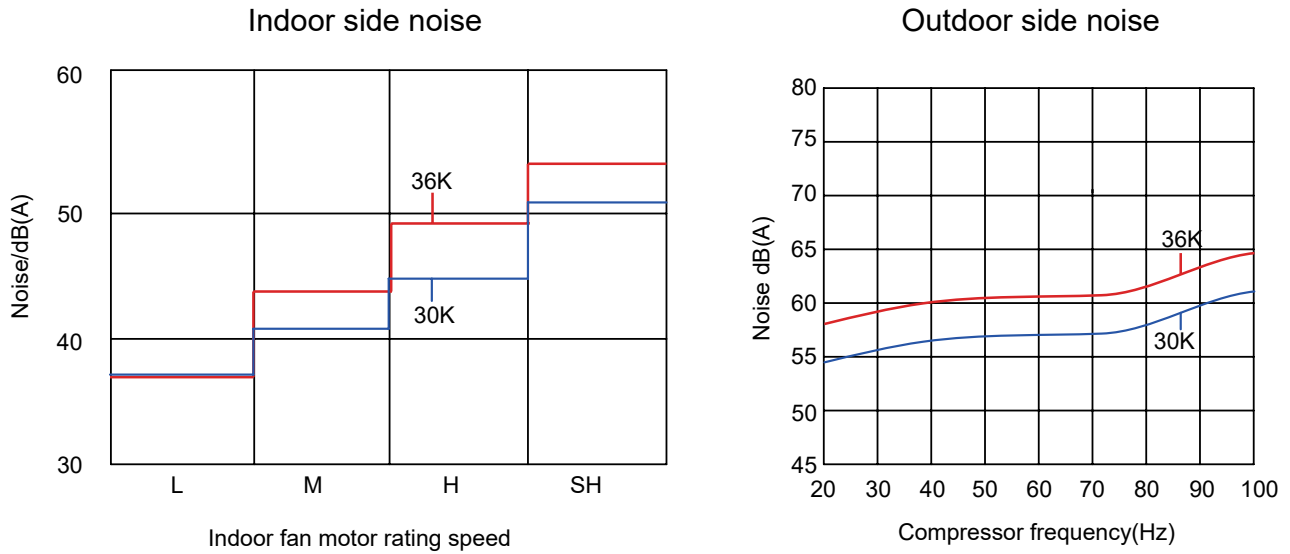

Figure 211  
36K Noise Curve

# SPECIFICATIONS

| Rated cooling connecting indoor and (DB/WB) |         | Model | Pressure of gas pipe connecting indoor and outdoor unit | Inlet and outlet pipe temperature of heat exchanger |                | Fan speed of indoor unit | Fan speed of outdoor unit | Compressor frequency (Hz) |
|---|---------|-------|---|---|----------------|--------------------------|---------------------------|---------------------------|
| Indoor                                      | Outdoor |       |   | PSI   | T1 (°F)        |                          |                           |                           |
| 80/67                                       | 95/75   | 9k    | 130.44-144.93   | in:46.4-51.8  | in:167-181.4   | Super High               | High                      | 52                        |
|   |         | 12k   |   | out:51.8-57.2                                       | out:98.6-118.4 |                          |                           | 72                        |
| 80/67                                       | 95/75   | 18k   | 130-142   | in:46.4-51.8  | in:167-181.4   | Super High               | High                      | 75                        |
| 80/67                                       | 95/75   | 24k   |   | out:51.8-57.2                                       | out:98.6-118.4 | Super High               | High                      | 87                        |
| 80/66                                       | 95/75   | 36k   | 130-145   | 46.8 to 52.8  | 127 to 96.8    | Super High               | High                      | 60                        |

T1: Inlet and outlet pipe temperature of evaporator  
T2: Inlet and outlet pipe temperature of condenser  
P: Pressure at the side of big valve  
Connection pipe length: 24.6ft.

**Figure 212**  
**Cooling Data Sheet in Rated Frequency**

| Rated Heating connecting indoor and (DB/WB) |             | Model | Pressure of gas pipe connecting indoor and outdoor unit | Inlet and outlet pipe temperature of heat exchanger |               | Fan speed of indoor unit | Fan speed of outdoor unit | Compressor frequency (Hz) |
|---|-------------|-------|---|---|---------------|--------------------------|---------------------------|---------------------------|
| Indoor                                      | Outdoor     |       |   | PSI   | T1 (°F)       |                          |                           |                           |
| 70/60                                       | 19.94/19.04 | 9k    | 362.32-405.80   | in:167-181.4  | in:33.8-37.4  | Super High               | High                      | 65                        |
|   |             | 12k   |   | out:98.6-113  | out:35.6-42.8 |                          |                           | 77                        |
| 70/60                                       | 47/43       | 18k   | 507-550   | in:167-181.4  | in:33.8-37.4  |                          |                           | 90                        |
| 70/60                                       | 47/43       | 24k   |   | out:98.6-113  | out:35.6-42.8 |                          |                           | 87                        |
| 70/-  | 20/19       | 36k   | 507-550   | 134.4 to 102  | 36 to 39      |                          |                           | 58                        |

T1: Inlet and outlet pipe temperature of evaporator  
T2: Inlet and outlet pipe temperature of condenser  
P: Pressure at the side of big valve  
Connection pipe length: 24.6ft.

**Figure 213**  
**Heating Data Sheet in Rated Frequency**

# SPECIFICATIONS

Unit: " (inches)

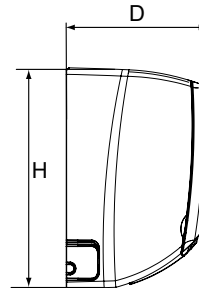
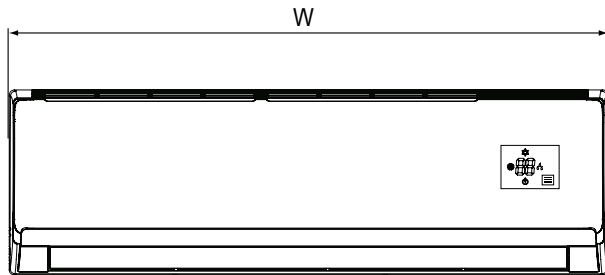

**09K**

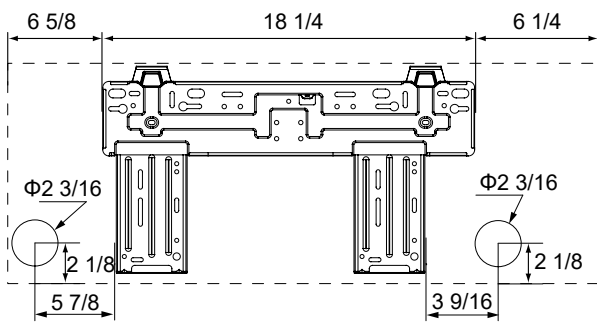

**12K**

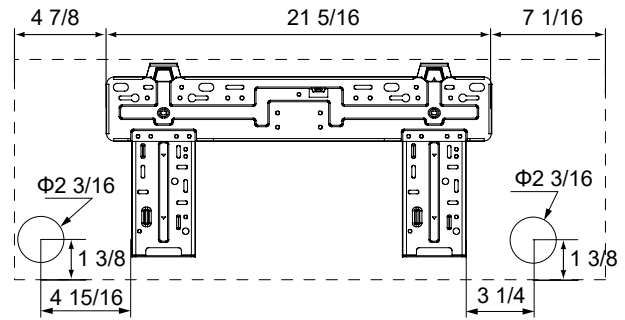

| Models | W      | H        | D     |
|--------|--------|----------|-------|
| 09K    | 31 1/8 | 10 13/16 | 7 7/8 |
| 12K    | 33 1/4 | 11 3/8   | 8 1/4 |

Figure 224

9-12K Indoor Unit Dimensions

# SPECIFICATIONS

Unit: " (inches)

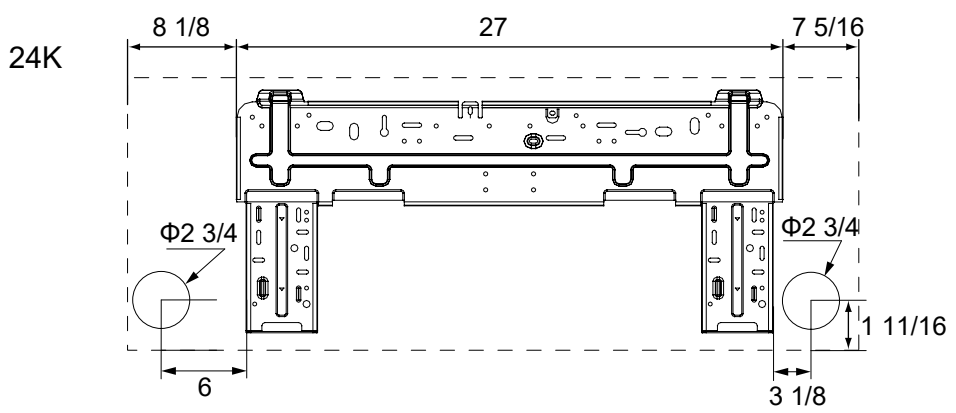
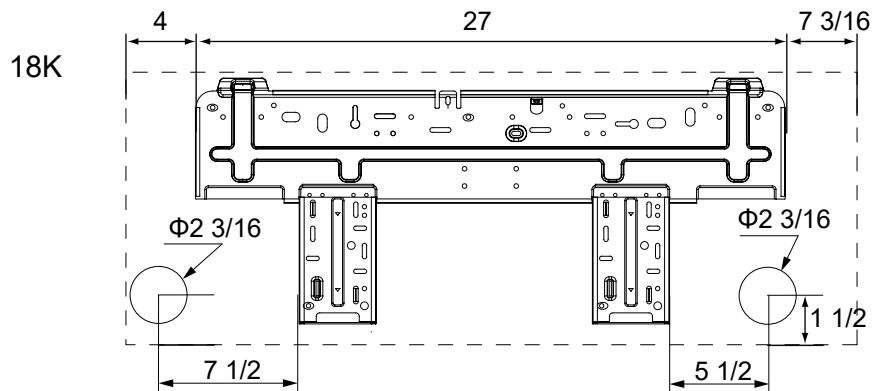
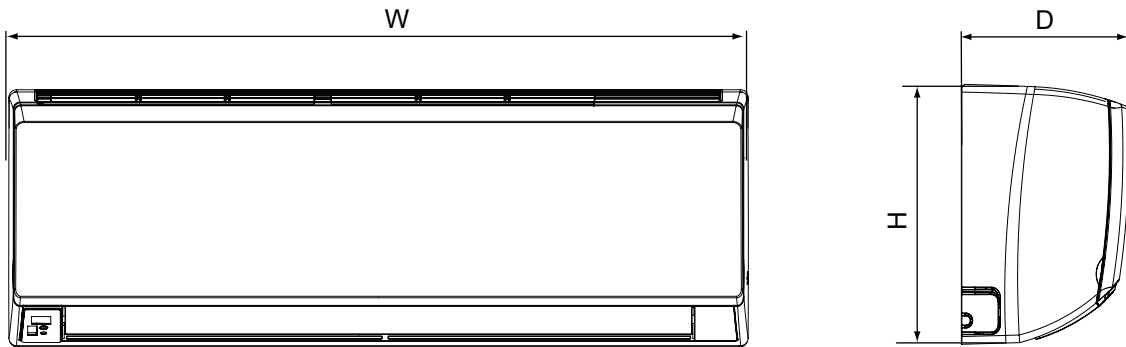

| Models | W       | H        | D       |
|--------|---------|----------|---------|
| 18K    | 38 3/16 | 11 13/16 | 8 13/16 |
| 24K    | 42 7/16 | 12 13/16 | 9 11/16 |

Figure 225

18-24K Indoor Unit Dimensions

# SPECIFICATIONS

Unit: " (inches)

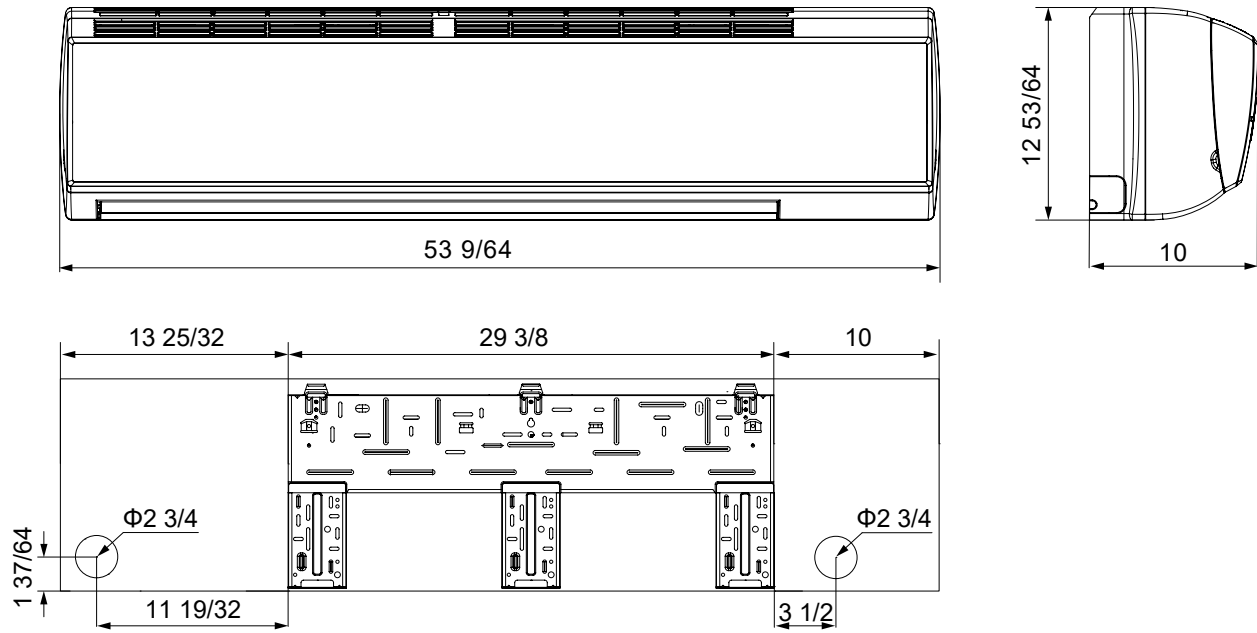

Figure 226

## 36K indoor Unit Dimensions

Unit: " (inches)

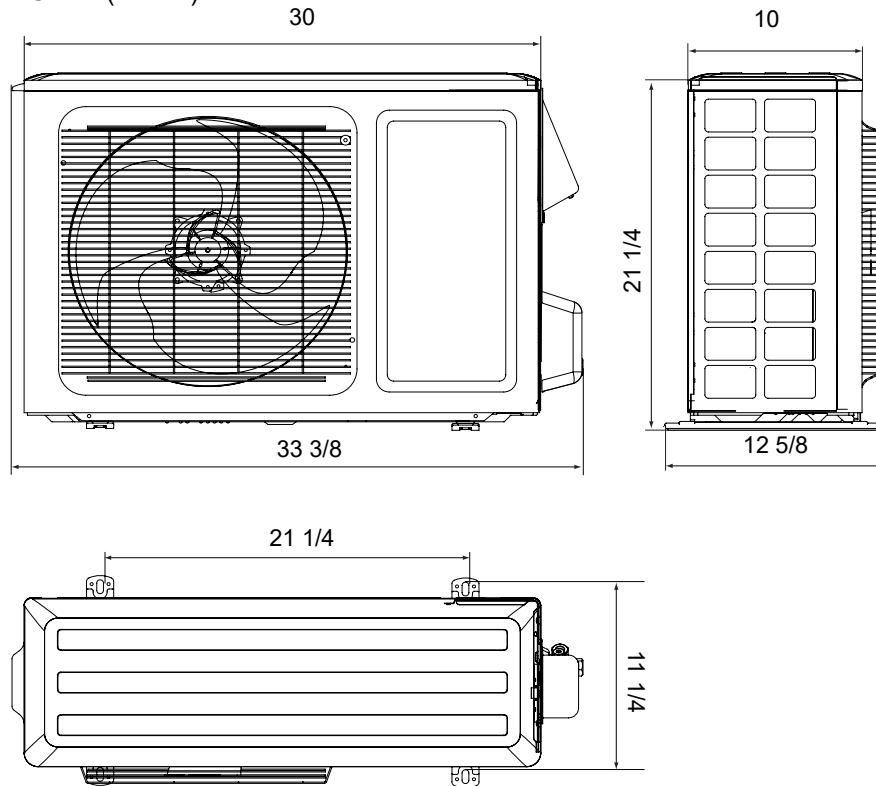

Figure 227

## 9-12K Outdoor Unit Dimensions

# SPECIFICATIONS

Unit: " (inches)

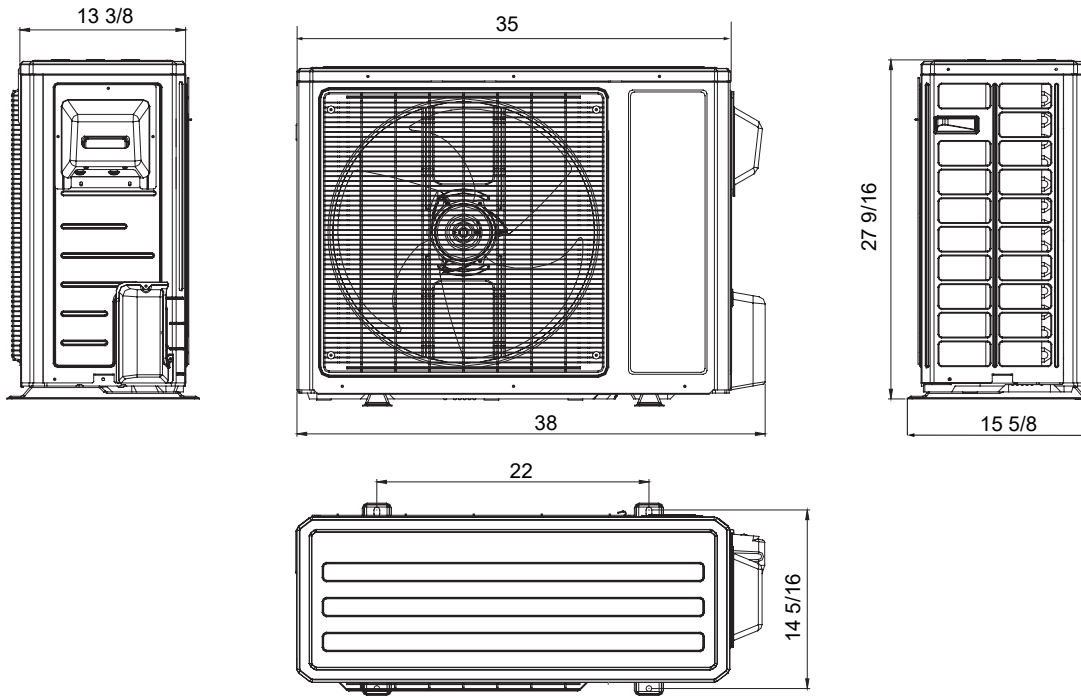

Figure 228

## 18-24K Outdoor Unit Dimensions

Unit: " (inches)

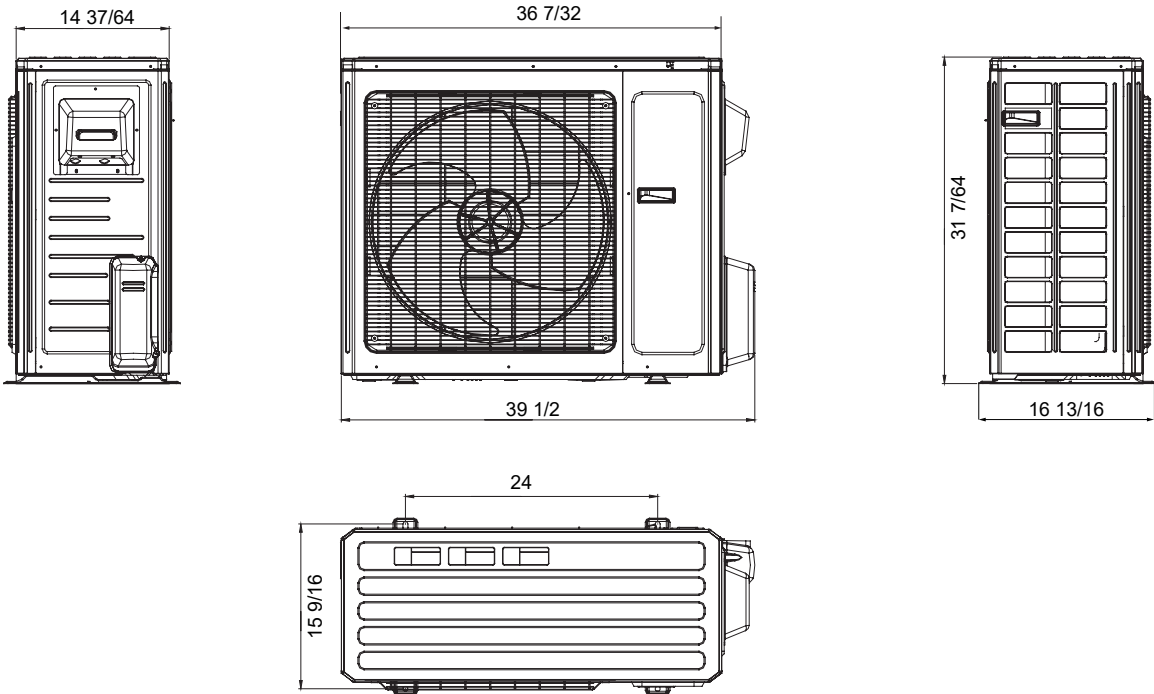

Figure 229

## 36K Outdoor Unit Dimensions

# OPERATION

69700657 / 69700623



## Introduction for icons on display screen

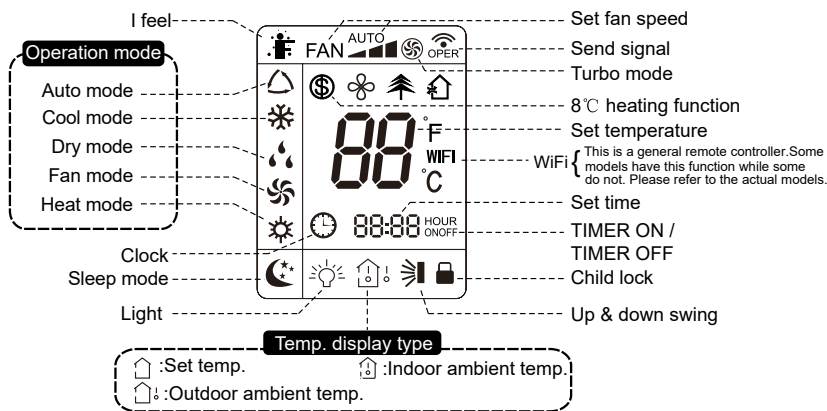

## Introduction for buttons on remote controller

### Note:

- This is a general use remote controller, it could be used for the air conditioners with multifunction; For some function, which the model doesn't have, if press the corresponding button on the remote controller that the unit will keep the original running status.
- After putting through the power, the air conditioner will give out a sound. Operation indicator "⏻" is ON (red indicator, the colour is different for different models). After that, you can operate the air conditioner by using remote controller.
- Under on status, pressing the button on the remote controller, the signal icon "📶" on the display of remote controller will blink once and the air conditioner will give out a "de" sound, which means the signal has been sent to the air conditioner.
- Under off status, set temperature and clock icon will be displayed on the display of remote controller (If timer on, timer off and light functions are set, the corresponding icons will be displayed on the display of remote controller at the same time); Under on status, the display will show the corresponding set function icons.

Figure 301

## Remote Control Button Identification



# OPERATION

## Remote Control Description

### 1. ON/OFF button

Press this button to turn on the unit. Press this button again to turn off the unit.

### 2. MODE button

Press this button to select your required operation mode.

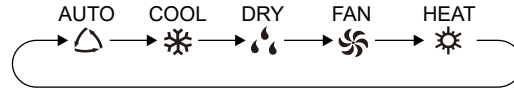

- When selecting auto mode, air conditioner will operate automatically according to ex-factory setting. Set temperature can't be adjusted and will not be displayed as well. Press "FAN" button can adjust fan speed. Press "SWING" button can adjust fan blowing angle.
- After selecting cool mode, air conditioner will operate under cool mode. Cool indicator on indoor unit is ON. (This indicator is not available for some models). Press "▲" or "▼" button to adjust set temperature. Press "FAN" button to adjust fan speed. Press "SWING" button to adjust fan blowing angle.
- When selecting dry mode, the air conditioner operates at low speed under dry mode. Dry indicator "💧" on indoor unit is ON. (This indicator is not available for some models). Under dry mode, fan speed can't be adjusted. Press "SWING" button to adjust fan blowing angle.
- When selecting fan mode, the air conditioner will only blow fan, no cooling and no heating. All indicators are OFF. Press "FAN" button to adjust fan speed. Press "SWING" button to adjust fan blowing angle.
- When selecting heating mode, the air conditioner operates under heat mode. Heat indicator on indoor unit is ON. (This indicator is not available for some models). Press "▲" or "▼" button to adjust set temperature. Press "FAN" button to adjust fan speed. Press "SWING" button to adjust fan blowing angle. (Cooling only unit won't receive heating mode signal. If setting heat mode with remote controller, press ON/OFF button can't start up the unit).

#### Note:

- For preventing cold air, after starting up heating mode, indoor unit will delay 1~5 minutes to blow air (actual delay time is depend on indoor ambient temperature).
- Set temperature range from remote controller: 60.8 ~ 86° F; Fan speed: auto, low speed, medium speed, high speed.

### 3. FAN button

Pressing this button can set fan speed circularly as: auto (AUTO), low (▲), medium (▲▲), high (▲▲▲).



#### Note:

- Under AUTO speed, air conditioner will select proper fan speed automatically according to ex-factory setting.
- Fan speed under dry mode is low speed.
- X-FAN function: Hold fan speed button in COOL or DRY mode, the icon "⊗" is displayed and the indoor fan will continue operation for a few minutes in order to dry the indoor unit even though you have turned off the unit. After energization, X-FAN OFF is defaulted. X-FAN is not available in AUTO, FAN or HEAT mode.

This function indicates that moisture on evaporator of indoor unit will be blown after the unit is stopped to avoid mould.

- Having set X-FAN function on: After turning off the unit by pressing ON/OFF button indoor fan will continue running for a few minutes. at low speed. In this period, Hold fan speed button to stop indoor fan directly.
- Having set X-FAN function off: After turning off the unit by pressing ON/OFF button, the complete unit will be off directly.

### 4. SWING button

Press this button can select up&down swing angle. Fan blow angle can be selected circularly as below:

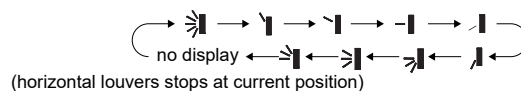

- When selecting "⊗", air conditioner is blowing fan automatically. Horizontal louver will automatically swing up & down at maximum angle.
- When selecting "↑", "↓", "↖", "↗", "↘", "↙", air conditioner is blowing fan at fixed position. Horizontal louver will stop at the fixed position.
- When selecting "↗", "↘", "↙", "↖", air conditioner is blowing fan at fixed angle. Horizontal louver will send air at the fixed angle.
- Hold "⊗" button above 2s to set your required swing angle. When reaching your required angle, release the button.

#### Note:

- "↗", "↘", "↙", "↖" may not be available. When air conditioner receives this signal, the air conditioner will blow fan automatically.

### 5. TURBO button

Under COOL or HEAT mode, press this button to turn to quick COOL or quick HEAT mode. "⊗" icon is displayed on remote controller. Press this button again to exit turbo function and "⊗" icon will disappear.

# OPERATION

## Remote Control Description

### 6. ▲/▼ button

- Press "▲" or "▼" button once increase or decrease set temperature 1° F. Holding "▲" or "▼" button, 2s later, set temperature on remote controller will change quickly. On releasing button after setting is finished, temperature indicator on indoor unit will change accordingly. (Temperature can't be adjusted under auto mode)
- When setting TIMER ON, TIMER OFF or CLOCK, press "▲" or "▼" button to adjust time. (Refer to CLOCK, TIMER ON, TIMER OFF buttons)

### 7. SLEEP button

Under COOL, HEAT mode, press this button to start up sleep function. "☾" icon is displayed on remote controller. Press this button again to cancel sleep function and "☾" icon will disappear.

### 8. TEMP button

By pressing this button, you can see indoor set temperature, indoor ambient temperature or outdoor ambient temperature on indoor units display. The setting on remote controller is selected circularly as below:

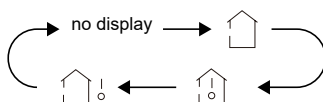

- When selecting "🏠" or no display with remote controller, temperature indicator on indoor unit displays set temperature.
- When selecting "🏠☀️" with remote controller, temperature indicator on indoor unit displays indoor ambient temperature.
- When selecting "🏠☀️🌞" with remote controller, temperature indicator on indoor unit displays outdoor ambient temperature.

#### Note:

- Outdoor temperature display is not available for some models. At that time, indoor unit receives "🏠☀️" signal, while it displays indoor set temperature.
- It's defaulted to display set temperature when turning on the unit. There is no display in the remote controller.
- Only for the models whose indoor unit has dual-8 display.
- When selecting displaying of indoor or outdoor ambient temperature, indoor temperature indicator displays corresponding temperature and automatically turn to display set temperature after three or five seconds.

### 9. WIFI button

Press "WiFi" button to turn on or turn off WiFi function. When WiFi function is turned on, the "WiFi" icon will be displayed on remote controller; Under status of remote controller off, press "MODE" and "WiFi" buttons simultaneously for 1s, WiFi module will restore to factory default setting.

- This function is only available for some models.

### 10. LIGHT button

Press this button to turn off display light on indoor unit. "☀️" icon on remote controller disappears. Press this button again to turn on display light. "☀️" icon is displayed.

### 11. CLOCK button

Press this button to set clock time. "🕒" icon on remote controller will blink. Press "▲" or "▼" button within 5s to set clock time. Each pressing of "▲" or "▼" button, clock time will increase or decrease 1 minute. If hold "▲" or "▼" button, 2s later, time will change quickly. Release this button when reaching your required time. Press "CLOCK" button to confirm the time. "🕒" icon stops blinking.

#### Note:

- Clock time adopts 24-hour mode.
- The interval between two operation can't exceed 5s. Otherwise, remote controller will quit setting status. Operation for TIMER ON/TIMER OFF is the same.

### 12. TIMER ON / TIMER OFF button

#### ● TIMER ON button

"TIMER ON" button can set the time for timer on. After pressing this button, "🕒" icon disappears and the word "ON" on remote controller blinks. Press "▲" or "▼" button to adjust TIMER ON setting. After each pressing "▲" or "▼" button, TIMER ON setting will increase or decrease 1min. Hold "▲" or "▼" button, 2s later, the time will change quickly until reaching your required time. Press "TIMER ON" to confirm it. The word "ON" will stop blinking. "🕒" icon resumes displaying. Cancel TIMER ON: Under the condition that TIMER ON is started up, press "TIMER ON" button to cancel it.

#### ● TIMER OFF button

"TIMER OFF" button can set the time for timer off. After pressing this button, "🕒" icon disappears and the word "OFF" on remote controller blinks. Press "▲" or "▼" button to adjust TIMER OFF setting. After each pressing "▲" or "▼" button, TIMER OFF setting will increase or decrease 1min. Hold "▲" or "▼" button, 2s later, the time will change quickly until reaching your required time. Press "TIMER OFF" word "OFF" will stop blinking. "🕒" icon resumes displaying. Cancel TIMER OFF. Under the condition that TIMER OFF is started up, press "TIMER OFF" button to cancel it.

---

# OPERATION

## Remote Control Description

### Note:

- Under on and off status, you can set TIMER OFF or TIMER ON simultaneously.
- Before setting TIMER ON or TIMER OFF, please adjust the clock time.
- After starting up TIMER ON or TIMER OFF, set the constant circulating valid. After that, air conditioner will be turned on or turned off according to setting time. ON/OFF button has no effect on setting. If you Don't need this function, please use remote controller to cancel it.

## Function introduction for combination buttons

### 1. Energy-saving function

Under cooling mode, press "TEMP" and "CLOCK" buttons simultaneously to start up or turn off energy-saving function. When energy-saving function is started up, "SE" will be shown on remote controller, and air conditioner will adjust the set temperature automatically according to ex-factory setting to reach to the best energy-saving effect. Press "TEMP" and "CLOCK" buttons simultaneously again to exit energy-saving function.

#### Note:

- Under energy-saving function, fan speed is defaulted at auto speed and it can't be adjusted.
- Under energy-saving function, set temperature can't be adjusted. Press "TURBO" button and the remote controller won't send signal.
- Sleep function and energy-saving function can't operate at the same time. If energy-saving function has been set under cooling mode, press sleep button will cancel energy-saving function. If sleep function has been set under cooling mode, start up the energy-saving function will cancel sleep function.

### 2. 46°F heating function

Under heating mode, press "TEMP" and "CLOCK" buttons simultaneously to start up or turn off 46°F heating function. When this function is started up, "Ⓢ" and "46°F" will be shown on remote controller, and the air conditioner keep the heating status at 46°F. Press "TEMP" and "CLOCK" buttons simultaneously again to exit 46°F heating function.

#### Note:

- Under 46°F heating function, fan speed is defaulted at auto speed and it can't be adjusted.
- Under 46°F heating function, set temperature can't be adjusted. Press "TURBO" button and the remote controller won't send signal.
- Sleep function and 46°F heating function can't operate at the same time. If 46°F heating function has been set under cooling mode, press sleep button will cancel 46°F heating function. If sleep function has been set under cooling mode, start up the 46°F heating function will cancel sleep function.
- Under °F temperature display, the remote controller will display 46 °F heating.

### 3. Child lock function

Press "▲" and "▼" simultaneously to turn on or turn off child lock function. When child lock function is on, "🔒" icon is displayed on remote controller. If you operate the remote controller, the "🔒" icon will blink three times without sending signal to the unit.

### 4. Temperature display switchover function

Under OFF status, press "▼" and "MODE" buttons simultaneously to switch temperature display between °C and °F.

### 5. I FEEL Function

Press "▲" and "MODE" buttons simultaneously to start I FEEL function and "🌡️" will be displayed on the remote controller. After this function is set, the remote controller will send the detected ambient temperature to the controller and the unit will automatically adjust the indoor temperature according to the detected temperature. Press this two buttons simultaneously again to close I FEEL function and "🌡️" will disappear.

- Please put the remote controller near user when this function is set. Do not put the remote controller near the object of high temperature or low temperature in order to avoid detecting inaccurate ambient temperature. When I FEEL function is turned on, the remote controller should be put within the area where indoor unit can receive the signal sent by the remote controller.

If "H1" is displayed on the remote controller while it's not operated by the professional person/after-sales person, it belongs to the misoperation.

Please operate it as below to cancel it. Under the OFF status of remote controller, hold the Mode button for 5s to cancel "H1" display.

#### Note:

- If remote controller displays "H1", it belongs to the normal function reminder. If the unit is defrosting under heating mode, it operates according to H1 defrosting mode. "H1" won't be displayed on the panel of indoor unit;
- Once you set H1 mode, if you turn off unit by remote controller, H1 will display 3 times on the remote controller and then disappear;
- Also, when you set H1 mode, when you change to heating mode, H1 will display 3 times on the remote controller and then disappear.

---

# OPERATION

## Remote Control Description

### Operation guide

1. After putting through the power, press "ON/OFF" button on remote controller to turn on the air conditioner.
2. Press "MODE" button to select your required mode: AUTO, COOL, DRY, FAN, HEAT.
3. Press "▲" or "▼" button to set your required temperature. (Temperature can't be adjusted under auto mode).
4. Press "FAN" button to set your required fan speed: auto, low, medium and high speed.
5. Press "SWING" button to select fan blowing angle.

### Replacement of batteries in remote controller

1. Press the back side of remote controller marked with "🔋", as shown in the fig, and then push out the cover of battery box along the arrow direction.
2. Replace two AAA 1.5V dry batteries, and make sure the position of "+" polar and "-" polar are correct.
3. Reinstall the cover of battery box.

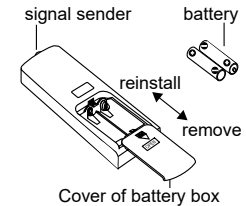

#### Note:

- During operation, point the remote control signal sender at the receiving window on indoor unit.
- The distance between signal sender and receiving window should be no more than 8m, and there should be no obstacles between them.
- Signal may be interfered easily in the room where there is fluorescent lamp or wireless telephone; remote controller should be close to indoor unit during operation.
- Replace new batteries of the same model when replacement is required.
- If you won't use remote controller for a long time, please take out the batteries.
- If the display on remote controller is fuzzy or there's no display, please replace batteries.

---

# OPERATION

## 9-24k Sequence of Operation

### 1. Basic function of system

#### (1) Cooling mode

- (1) Under this mode, fan and swing operates at setting status. Temperature setting range is 60.8~86.0°F.
- (2) During malfunction of outdoor unit or the unit is stopped because of protection, indoor unit keeps original operation status.

#### (2)Drying mode

- (1) Under this mode, fan operates at low speed and swing operates at setting status. Temperature setting range is 60.8~86.0°F.
- (2) If the outdoor unit malfunctions, or the unit is stopped because of protection, indoor unit keeps original operation status.
- (3) Protection status is same as that under cooling mode.
- (4) Sleep function is not available for drying mode.

#### (3)Heating mode

- (1) Under this mode, Temperature setting range is 60.8~86.0°F.
- (2) Working condition and process for heating mode:

When unit heating mode is turned on, the indoor unit enters into cold air prevention status. When the unit is stopped or at OFF status, and indoor unit has been initially started, the unit enters into residual heat-blowing status.

#### (4)Working method for AUTO mode:

1. Working condition and process for AUTO mode:
  - a. Under AUTO mode, standard heating Tpreset=68.0°F and standard cooling Tpreset=77.0°F. The unit will switch mode automatically according to ambient temperature.
2. Protection function
  - a. During cooling operation, protection function is same as that under cooling mode.
  - b. During heating operation, protection function is same as that under heating mode.
3. Display: Set temperature is the set value under each condition. Ambient temperature is (Tamb.-Tcompensation) for heat pump unit and Tamb. for cooling only unit.
4. If there's I feel function, Tcompensation is 0. Others are same as above.

#### (5)Fan mode

Under this mode, indoor fan operates at set fan speed. Compressor, outdoor fan, 4-way valve and electric heating tube stop operation. Indoor fan can select to operate at high, medium, low or auto fan speed. Temperature setting range is 60.8~86.0°F.

### 2. Other control

#### (1) Buzzer

Upon energization or command from the unit or remote controller, the buzzer will give out a beep.

#### (2) Auto button

If press this auto button when turning off the unit, the complete unit will operate at auto mode. Indoor fan operates at auto fan speed and swing function is turned on. Press this auto button at ON status to turn off the unit.

#### (3) Auto fan

Heating mode: During auto heating mode or normal heating mode, auto fan speed will adjust the fan speed automatically according to ambient temperature and set temperature.

#### (4) Sleep

After setting sleep function for a period of time, system will adjust set temperature automatically.

#### (5) Timer function:

General timer and clock timer functions are compatible by equipping remote controller with different functions.

#### (6) Memory function

Memorized compensation temperature, off-peak energization value.

Memory content: mode, up&down swing, light, set temperature, set fan speed, general timer (clock timer can't be memorized).

After power recovery, the unit will be turned on automatically according to memory content.

#### (7) Health function

Turn on the unit by pressing auto button, and the health is defaulted ON.

---

# OPERATION

## 9-24k Sequence of Operation

### (8) I feel control mode

After controller received I feel control signal and ambient temperature sent by remote controller, controller will work according to the ambient temperature sent by remote controller.

### (9) Compulsory defrosting function

(1) Start up compulsory defrosting function

Under ON status, set heating mode with remote controller and adjust the temperature to 60.8°F. Press "+, -, +, -, +, -" button successively within 5s and the complete unit will enter into compulsory defrosting status. Meanwhile, heating indicator on indoor unit will ON 10s and OFF 0.5s successively. (Note: If complete unit malfunctions or stops operation due to protection, compulsory defrosting function can be started up after malfunction or protection is resumed.)

(2) Exit compulsory defrosting mode

After compulsory defrosting is started up, the complete unit will exit defrosting operation according to the actual defrosting result, and the complete unit will resume normal heating operation.

### (10) Refrigerant recovery function:

(1) Enter refrigerant recycling function

Within 5min after energizing (unit ON or OFF status), continuously press LIGHT button for 3 times within 3s to enter refrigerant recycling mode; Fo is displayed and refrigerant recycling function is started. At this moment, the maintenance people closes liquid valve. After 5min, stick the thimble of maintenance valve with a tool. If there is no refrigerant spraying out, close the gas valve immediately and then turn off the unit to remove the connection pipe.

(2) Exit refrigerant recycling function

After entering refrigerant recycling mode, when receive any remote control signal or enter refrigerant recycling mode for 25min, the unit will exit refrigerant recycling mode automatically. If the unit is in standby mode before refrigerant recycling, it will be still in standby mode after finishing refrigerant recycling; if the unit is in ON status before refrigerant recycling, it will still run in original operation mode.

### (11) Ambient temperature display control mode

1. When user set the remote controller to display set temperature (corresponding remote control code: 01), current set temperature will be displayed.

2. Only when remote control signal is switched to indoor ambient temperature display status (corresponding remote control code: 10) from other display status (corresponding remote control code: 00, 01, 11), controller will display indoor ambient temperature for 3s and then turn back to display set temperature.

Under this mode, indoor fan operates at set fan speed. Compressor, outdoor fan, 4-way valve and electric heating tube stop operation. Indoor fan can select to operate at high, medium, low or auto fan speed. Temperature setting range is 60.8~86.0°F.

### (12) Off-peak energization function:

Adjust compressors minimum stop time. The original minimum stop time is 180s and then we change to:

The time interval between two start-ups of compressor can't be less than  $180+T$  s ( $0 \leq T \leq 15$ ). T is the variable of controller. That's to say the minimum stop time of compressor is 180s~195s.

### (13) X-fan mode

When X-fan function is turned on, after turn off the unit, indoor fan will still operate at low speed for 2min and then the complete unit will be turned off. When x-fan function is turned off, after turn off the unit, the complete unit will be turned off directly.

### (14) 46° heating function

Under heating mode, you can set 46° heating function by remote controller. The system will operate at 46° set temperature.

### (15) Turbo fan control function

Set turbo function under cooling or heating mode to enter into turbo fan speed. Press fan speed button to cancel turbo wind.

No turbo function under auto, dry or fan mode.

---

# OPERATION

## 9-24k Sequence of Operation

### Outdoor Units

#### 1. Input Parameter Compensation and Calibration

##### (1) Check the ambient temperature compensation function Indoor ambient temperature compensation function.

- In cooling mode, the indoor ambient temperature participating in computing control = (T<sub>indoor ambient temperature</sub> - Δ T<sub>cooling indoor ambient temperature compensation</sub>)
- In heating mode, the indoor ambient temperature participating in computing control = (T<sub>indoor ambient temperature</sub> - Δ T<sub>heating indoor ambient temperature compensation</sub>)

##### (2) Check effective judgment controls of parameters

Effective judgment function of the outdoor exhaust temperature thermo-bulb When conditions a and b are satisfied, the outdoor exhaust temperature thermo-bulb is judged not to be connected into place, the mainboard of outer units will display failure of the outdoor exhaust temperature thermo-bulb (not connected into place), stop the machine for repairing, and resume the machine by remote controls of ON/OFF.

###### a. Judgment of exhaust detection temperature change:

After the compressor starts up and runs for 10 minutes, if the compressor frequency  $f \geq 40\text{Hz}$ , and the rising value  $T_{\text{exhaust}}$  ( $T_{\text{exhaust}}$  (after start-up for 10 minutes) -  $T_{\text{exhaust}}$  (before start-up))  $< 35.6^\circ\text{F}$ , the outdoor exhaust temperature thermo-bulb can be judged not to be connected into place (judging once when the power is on the first time).

b. Comparative judgment of exhaust detection temperature and condenser detection temperature (T<sub>pipe temperature</sub> = T<sub>outdoor pipe temperature</sub> in cooling mode, T<sub>pipe temperature</sub> = T<sub>indoor pipe temperature</sub> in heating mode): After the compressor starts up and runs for 10 minutes, if the compressor frequency  $f \geq 40\text{Hz}$ , and T<sub>pipe temperature</sub>  $\geq (T_{\text{exhaust}} + 37.4)$ , the outdoor exhaust temperature thermobulb can be judged not to be connected into place (judging once when power is on the first time).

### 2. Basic Functions

#### (1) Cooling Mode

##### 1. Conditions and processes of cooling operation:

- If the compressor is shut down, and  $[T_{\text{setup}} - (T_{\text{indoor ambient temperature}} - \Delta T_{\text{cooling indoor ambient temperature compensation}})] \leq 32.9^\circ\text{F}$ , start up the machine for cooling, the cooling operation will start;
- During operations of cooling, if  $32^\circ\text{F} \leq [T_{\text{setup}} - (T_{\text{indoor ambient temperature}} - \Delta T_{\text{cooling indoor ambient temperature compensation}})] < 35.6^\circ\text{F}$ , the cooling operation will be still running;
- During operations of cooling, if  $35.6^\circ\text{F} \leq [T_{\text{setup}} - (T_{\text{indoor ambient temperature}} - \Delta T_{\text{cooling indoor ambient temperature compensation}})]$ , the cooling operation will stop after reaching the temperature point.

##### 2. Temperature setting range

- If T<sub>outdoor ambient temperature</sub>  $\geq [T_{\text{low-temperature cooling temperature}}]$ , the temperature can be set at: 61~86°F (Cooling at room temperature);
- If T<sub>outdoor ambient temperature</sub>  $< [T_{\text{low-temperature cooling temperature}}]$ , the temperature can be set at: 77~86°F (Cooling at low temperature), that is, the minimum setting temperature for outer units judgment is 77°F.

#### (2) Dehumidifying Mode

- Conditions and processes of dehumidifying operations: Same as the cooling mode;
- The temperature setting range is: 61~86°F;

#### (3) Air-supplying Mode

- The compressor, outdoor fans and four-way valves are switched off;
- The temperature setting range is: 61~86°F.

#### (4) Heating Mode

1. Conditions and processes of heating operations: (T<sub>indoor ambient temperature</sub> is the actual detection temperature of indoor environment thermo-bulb, T<sub>heating indoor ambient temperature compensation</sub> is the indoor ambient temperature compensation during heating operations)

- If the compressor is shut down, and  $[(T_{\text{indoor ambient temperature}} - \Delta T_{\text{heating indoor ambient temperature compensation}}) - T_{\text{setup}}] \leq 32.9^\circ\text{F}$ , start the machine to enter into heating operations for heating;
  - During operations of heating, if  $32^\circ\text{F} \leq [(T_{\text{indoor ambient temperature}} - \Delta T_{\text{heating indoor ambient temperature compensation}}) - T_{\text{setup}}] < 35.6^\circ\text{F}$ , the heating operation will be still running;
  - During operations of heating, if  $35.6^\circ\text{F} \leq [(T_{\text{indoor ambient temperature}} - \Delta T_{\text{heating indoor ambient temperature compensation}}) - T_{\text{setup}}]$ , the heating operation will stop after reaching the temperature point.
2. The temperature setting range in this mode is: 61~86°F.

---

# OPERATION

## 9-24k Sequence of Operation

### 3. Special Functions

#### Defrosting Control

① Conditions for starting defrosting

After the time for defrosting is judged to be satisfied, if the temperature for defrosting is satisfied after detections for continuous 3minutes, the defrosting operation will start.

② Conditions of finishing defrosting

The defrosting operation can exit when any of the conditions below is satisfied:

③  $T_{\text{outdoor pipe temperature}} \geq (T_{\text{outdoor ambient temperature}} - [T_{\text{temperature 1 of finishing defrosting}}])$ ;

④ The continuous running time of defrosting reaches [tmax. defrosting time].

### 4. Control Logic

#### (1) Compressor Control

Start the compressor after starting cooling, heating, dehumidifying operations, and the outer fans start for 5s; When the machine is shutdown, in safety stops and when switching to air-supplying mode, the compressor will stop immediately. In all modes: once the compressor starts up, it will not be allowed to stop until having run for the [tmin. compressor running time] (Note: including cases of shutdown when the temperature point is reached; except the cases requiring stopping the compressor such as fault protection, remote shutdown, mode switching etc.); In all modes: once the compressor stops, it will be allowed be restart after 3-minute delay (Note: The indoor units have a function of power memory, the machine can be restarted after remote shutdown and powering up again without delay).

##### 1. Cooling mode

Start the machine to enter into cooling operation for cooling, the compressor is switched on.

##### 2. Dehumidifying mode

Same as the cooling mode.

##### 3. Air-supplying mode

The compressor is switched off.

##### 4. Heating mode

(1) Start the machine to enter into heating operation for heating, the compressor is switched on.

(2) Defrosting:

a. Defrosting starts: the compressor is shut down, and restarts it after 55-second delay.

b. Defrosting ends: the compressor stops, then starts it after 55-second delay.

#### (2) Outer Fans Control

Notes:

Only the outer fans run for at least 80s in each air flow speed can the air flow be switched;

After the outer fans run compulsively in high speed for 80s when the machine starts up, control the air flow according to the logic.

After remote shutdown, safety stops, and when the machine stops after reaching the temperature point, as well as after the compressor stops, extend 1 minute, the outer fans will stop (During the period in the 1 minute, the air flow of outer fans can be changed according to the outdoor ambient temperature changes); When running with force, the outdoor fans shall run in the highest air flow.

#### (3) 4-way valve control

1. The 4-way valve control under the modes of Cooling, dehumidification and supplying air: closing;

2. The status of 4-way valve control under the heating mode: getting power;

(1) 4-way valve power control under heating mode

a. Starts the machine under heating mode, the 4-way valve will get power immediately.

(2) 4-way valve power turn-off control under heating mode

a. When you should turn off the power or switch to other mode under heating mode, the power of 4-way valve will be cut after 2 minutes of the compressor stopped.

b. When all kinds of protection stops, the power of 4-way valve will be cut after delaying 4 minutes.

(3) Defrosting control under heating mode:

a. Defrosting begins: The power of 4-way valve will be cut after 50s of entering into the defrosting compressor.

b. Defrosting stops: The 4-way valve will get power after 50s of exiting the defrosting compressor.

#### (4) Evaporator frozen-preventing protection function

At the mode of Cooling, dehumidifying:

Evaporator frozen-preventing protection function is allowed to begin after 6 min of starting the compressor.



---

# OPERATION

## 9-24k Sequence of Operation

### 1. Starting estimation:

After the compressor stopped working for 180s, if  $T_{\text{inner pipe}} > [T_{\text{frozen-preventing frequency-limited temperature}}$  (the temperature of hysteresis is 35.6°F)), the machine is only allowed to start for operating, otherwise it should not be started, and should be stopped to treat according to the frozen-preventing protection: Clear the trouble under the mode of power turn-off / heating, and the protection times are not counted.

### 2. Frequency limited

$[T_{\text{frozen-preventing normal speed frequency-reducing temperature}}] \leq [T_{\text{inner pipe}} T_{\text{frozen-preventing frequency-limited temperature}}]$ , you should limit the frequency raising of compressor.

### 3. Reducing frequency at normal speed:

If  $[T_{\text{frozen-preventing high speed frequency-reducing temperature}}] \leq [T_{\text{inner pipe}} T_{\text{frozen-preventing normal speed frequency-reducing temperature}}]$ , you should adjust the compressor frequency by reducing 8Hz/90s till the lower limit;

### 4. Reducing frequency at high speed:

If  $[T_{\text{frozen-preventing power turn-off temperature}}] \leq T_{\text{inner pipe}} [T_{\text{frozen-preventing high speed frequency-reducing temperature}}]$  you should adjust the compressor frequency by reducing 30Hz/90s till the lower limit;

### 5. Power turn-off:

If the  $T_{\text{inner pipe}} < [T_{\text{frozen-preventing power turn-off temperature}}]$ , then frozen-preventing protect to stop the machine; If  $T_{\text{frozen-preventing frequency-limited temperature}} < T_{\text{inner pipe}}$ , and the compressor has stopped working for 3 minutes, the whole machine should be allowed to operate.

6. If the frozen-preventing protection power turn-off continuously occurs for six times, it should not be resumed automatically, and you should press the ON/OFF button to resume if the fault keeps on. During the process of running, if the running time of compressor exceeds the t evaporator frozen-preventing protection times zero clearing time, the times of frozen-preventing power turn-off should be cleared to recount. The mode of stopping the machine or transferring to supply air will clear the trouble times immediately (if the trouble can not be resumed, mode transferring will not clear it).

## (5) Overload protection function

Overload protection function at the mode of Cooling and dehumidifying

### 1. Starting estimation:

After the compressor stopped working for 180s, if  $T_{\text{outer pipe}} < [T_{\text{Cooling overload frequency-limited temperature}}]$  (the temperature of hysteresis is 35.6°F), the machine is allowed to start, otherwise it should not be started, and should be stopped to treat according to the overload protection: Clear the trouble at the mode of power turn-off / heating, and the protection times are not counted.

### 2. Frequency limited

If  $[T_{\text{Cooling overload frequency-limited temperature}}] \leq [T_{\text{outer pipe}} T_{\text{Cooling overload frequency reducing temperature at normal speed}}]$ , you should limit the frequency raising of compressor.

### 3. Reducing frequency at normal speed and power turn-off:

If  $[T_{\text{Cooling overload frequency reducing temperature at high speed}}] \leq T_{\text{outer pipe}} < [T_{\text{Cooling overload power turn-off temperature}}]$ , you should adjust the compressor frequency by reducing 8Hz/90s till the lower limit; After it was running 90s at the lower limit, if  $[T_{\text{Cooling overload frequency reducing temperature at normal speed}}] \leq T_{\text{outer pipe}}$ , then Cooling overload protects machine stopping;

### 4. Reducing frequency at high speed and stop machine:

If  $[T_{\text{Cooling overload frequency reducing temperature at high speed}}] \leq T_{\text{outer pipe}} [T_{\text{Cooling overload power turn-off temperature}}]$ , you should adjust the compressor frequency by reducing 30Hz/90s till the lower limit; After it was running 90s at the lower limit, if  $[T_{\text{Cooling overload frequency reducing temperature at normal speed}}] \leq [T_{\text{outer pipe}}]$ , then Cooling overload protects machine stopping;

### 5. Power turn-off:

If the  $[T_{\text{Cooling overload power turn-off temperature}}] \leq T_{\text{outer pipe}}$ , then Cooling overload protects machine stopping; If  $[T_{\text{outer pipe}}] < [T_{\text{Cooling overload frequency-limited temperature}}]$  and the compressor has been stopped working for 3 minutes, the machine should be allowed to operate.

6. If the Cooling overload protection power turn-off continuously occurs for six times, it should not be resumed automatically, and you should press the ON/OFF button to resume if the fault keeps on. During the process of running, if the running time of compressor exceeds the t overload protection times zero clearing time, the times of overload protection power turn-off should be cleared to recount. The mode of stopping the machine or transferring to supply air will clear the trouble times immediately (if the trouble can not be resumed, transferring mode will not clear it).

## Overload protection function at the mode of heating

### Starting estimation :

After the compressor stopped working for 180s, if  $T_{\text{inner pipe}} < T_{\text{heating overload frequency-limited temperature}}$  (the temperature of hysteresis is 35.6°F), the machine is allowed to start, otherwise it should not be started, and should be stopped to treat according to the overload protection:

Clear the trouble at the mode of power turn-off / heating, and the protection times are not counted.

---

# OPERATION

## 9-24k Sequence of Operation

### 1. Frequency limited

If  $[T_{\text{heating overload frequency-limited temperature}}] \leq T_{\text{inner pipe}} < [T_{\text{heating overload frequency reducing temperature at normal speed}}]$ , you should limit the frequency raising of compressor.

### 2. Reducing frequency at normal speed and stopping machine:

If  $T_{\text{heating overload frequency reducing temperature at normal speed}} \leq T_{\text{inner pipe}} < [T_{\text{heating overload frequency reducing temperature at high speed}}]$ , you should adjust the compressor frequency by reducing 8Hz/90s till the lower limit; After it was running 90s at the lower limit, if  $T_{\text{heating overload frequency reducing temperature at normal speed}} \leq T_{\text{inner pipe}}$ , then overload protects machine stopping;

### 3. Reducing frequency at high speed and power turn-off:

If  $[T_{\text{heating overload frequency reducing temperature at high speed}}] \leq T_{\text{inner pipe}} < [T_{\text{heating overload power turn-off temperature}}]$ , you should adjust the compressor frequency by reducing 30Hz/90s till the lower limit; After it was running 90s at the lower limit, if  $T_{\text{heating overload frequency reducing temperature at normal speed}} \leq T_{\text{outer pipe}}$ , then Cooling overload protects machine stopping;

### 4. Power turn-off:

If the  $[T_{\text{heating overload power turn-off temperature}}] \leq T_{\text{inner pipe}}$ , then overload protects machine stopping; If  $T_{\text{inner pipe}} > T_{\text{heating overload frequency-limited temperature}}$  and the compressor has been stopped working for 3 minutes, the machine should be allowed to operate.

5. If the overload protection power turn-off continuously occurs for six times, it should not be resumed automatically, and you should press the ON/OFF button to resume if the fault keeps on. During the process of running, if the running time of compressor exceeds the  $t_{\text{overload protection times zero clearing time}}$ , the times of overload protection power turn-off should be cleared to recount. The mode of stopping the machine or transferring to supply air will clear the trouble times immediately (if the trouble can not be resumed, transferring mode will not clear it). Protective function for discharge temperature of compressor

### 1. Starting estimation:

After the compressor stopped working for 180s, if  $T_{\text{Discharge}} < T_{\text{Discharge limited temperature}}$  (the temperature of hysteresis is 35.6°F), the machine is allowed to start, otherwise it should not be started, and should be stopped to treat according to the discharge temperature:

The machine should be stopped or transferred to supply air, the trouble should be cleared immediately, and the protection times are not counted.

### 2. Frequency limited

If  $[T_{\text{limited frequency temperature during discharging}}] \leq T_{\text{Discharge}} < [T_{\text{frequency reducing temperature at normal speed during discharging}}]$ , you should limit the frequency raising of compressor.

### 3. Reducing frequency at normal speed and stopping machine:

If  $[T_{\text{frequency reducing temperature at normal speed during discharging}}] \leq T_{\text{Discharge}} < [T_{\text{frequency reducing temperature at high speed during discharging}}]$ , you should adjust the compressor frequency by reducing 8Hz/90s till the lower limit; After it was running 90s at the lower limit, if  $[T_{\text{frequency reducing temperature at normal speed during discharging}}] \leq T_{\text{Discharge}}$ , you should discharge to protect machine stopping;

### 4. Reducing frequency at high speed and power turn-off:

If  $[T_{\text{frequency reducing temperature at high speed during discharging}}] \leq T_{\text{Discharge}} < [T_{\text{stop temperature during discharging}}]$ , you should adjust the compressor frequency by reducing 30Hz/90s till the lower limit; After it was running 90s at the lower limit, if  $[T_{\text{frequency reducing temperature at normal speed during discharging}}] \leq T_{\text{Discharge}}$ , you should discharge to protect machine stopping;

### 5. Power turn-off:

If the  $[T_{\text{power turn-off temperature during discharging}}] \leq T_{\text{Discharge}}$ , you should discharge to protect machine stopping; If  $T_{\text{Discharge}} < [T_{\text{limited frequency temperature during discharging}}]$  and the compressor has been stopped for 3 minutes, the machine should be allowed to operate.

6. If the discharging temperature protection of compressor continuously occurs for six times, it should not be resumed automatically, and you should press the ON/OFF button to resume. During the process of running, if the running time of compressor exceeds the  $t_{\text{Protection times clearing of discharge}}$ , the discharge protection is cleared to recount. Stopped or transferred to supply air mode will clear the trouble times immediately (if the trouble can not be resumed, mode transferring also will not clear it).

### 7. Frequency limited

If  $[I_{\text{limited frequency when overcurrent}}] \leq I_{\text{AC Electric current}} < [I_{\text{frequency reducing when overcurrent}}]$ , you should limit the frequency raising of compressor.

### 8. Reducing frequency:

If  $[I_{\text{frequency reducing when overcurrent}}] \leq [I_{\text{AC Electric current}} \text{ I Power turn-off when overcurrent}]$ , you should reduce the compressor frequency till the lower limit or exit the frequency reducing condition;

### 9. Power turn-off:

If  $[I_{\text{power turn-off machine when overcurrent}}] \leq [I_{\text{AC Electric current}}]$ , you should carry out the overcurrent stopping protection; If  $I_{\text{AC Electric current}} < [I_{\text{limited frequency when overcurrent}}]$  and the compressor has been stopped for 3 minutes, the machine should be allowed to operate.

10. If the overcurrent protection continuously occurs for six times, it should not be resumed automatically, and you should press the ON/OFF button to resume. During the process of running, if the running time of compressor exceeds the  $[t_{\text{Protection times clearing of over current}}]$ , the discharge protection is cleared to recount.

# OPERATION

## 9-24k Sequence of Operation

### (6)Voltage sag protection

After start the compressor, if the time of DC link Voltage sag [ $U_{\text{Sagging protection voltage}}$ ] is measured to be less than t Voltage sag protection time , the machine should be stop at once, hand on the voltage sag trouble, reboot automatically after 30 minutes.

### (7)Communication fault

When you have not received any correct signal from the inner machine in three minutes, the machine will stop for communication fault. When you have not received any correct signal from driver IC (aim to the controller for the separating of main control IC and driver IC), and the machine will stop for communication fault. If the communication is resumed, the machine will be allowed to operate.

### (8)Module protection

Testing the module protective signal immediately after started, once the module protective signal is measured, stop the machine with module protection immediately. If the module protection is resumed, the machine will be allowed to operate. If the module protection continuously occurs for three times, it should not be resumed automatically, and you should press the ON/OFF button to resume. If the running time of compressor exceeds the [ $t_{\text{Protection times clearing of module}}$ ] , the module protection is cleared to recount.

### (9)Module overheating protection

#### 1. Starting estimation:

After the compressor stopped working for 180s, if  $T_{\text{Module}} < [T_{\text{Module frequency limited temperature}}]$  (the temperature of hysteresis is 35.6°F ), the machine is allowed to start, otherwise it should not be started, and should be stopped to treat according to the module overheating protection: The machine should be stopped or transferred to supply air, the trouble should be cleared immediately, and the protection times are not counted.

#### 2. Frequency limited

If  $[T_{\text{Limited frequency temperature of module}}] \leq T_{\text{Module}} < [T_{\text{frequency reducing temperature at normal speed of module}}]$  , you should limit the frequency raising of compressor.

#### 3. Reducing frequency at normal speed and power turn-off:

If  $[T_{\text{frequency reducing temperature at normal speed of module}}] \leq T_{\text{Module}} < [T_{\text{frequency reducing temperature at high speed of module}}]$ , you should adjust the compressor frequency by reducing 8Hz/90s till the lower limit; After it was running 90s at the lower limit, if  $[T_{\text{frequency reducing temperature at normal speed of module}}] \leq T_{\text{Module}}$ , you should stop the machine for module overheating protection;

#### 4. Reducing frequency at high speed and power turn-off:

If  $[T_{\text{frequency reducing temperature at high speed of module}}] \leq T_{\text{Module}} < [T_{\text{Power turn-off temperature of module}}]$  you should adjust the compressor frequency by reducing 30Hz/90s till the lower limit; After it was running 90s at the lower limit, if  $[T_{\text{frequency reducing temperature at normal speed of module}}] \leq T_{\text{Module}}$ , you should stop the machine for module overheating protection;

#### 5. Power turn-off:

If the  $[T_{\text{Power turn-off temperature of module}}] \leq T_{\text{Module}}$ , you should stop the machine for module overheating protection; If  $T_{\text{Module}} < [T_{\text{Limited frequency temperature of module}}]$  and the compressor has been stopped for 3 minutes, the machine should be allowed to operate.

6. If protection continuously occurs for six times, it should not be resumed automatically, and you should press the ON/OFF button to resume. During the process of running, if the running time of compressor exceeds the [ $t_{\text{Protection times clearing of module}}$ ] , the discharge protection is cleared to recount. Stopped or transferred to supply air mode will clear the trouble times immediately (if the trouble can not be resumed, mode transferring also will not clear it).

### (10)Compressor overloads protection

If you measure the compressor overload switch action in 3s, the compressor should be stopped for overloading. The machine should be allowed to operate after overload protection was measured to resume. If the overloading protection continuously occurs for three times, it should not be resumed automatically, and you should press the ON/OFF button to resume. The protection times of compressor is allowed to clear after the compressor run [ $t_{\text{Protection times clearing of compressor overloading}}$ ] 30 minutes.

### (11)Phase current overcurrent protection of compressor

During the running process of compressor, you could measure the phase current of the compressor, and control it according to the following steps:

#### 1. Frequency limited

If  $[I_{\text{Limited frequency phase current}}] \leq [I_{\text{Phase current T frequency reducing phase current}}]$  , you should limit the frequency raising of compressor.

#### 2. Reducing Frequency

If  $[I_{\text{Frequency Reducing Phase Current}}] \leq [I_{\text{Phase Current}}] < [I_{\text{Power Turn-Off Phase Current}}]$ , the compressor shall continue to reduce frequency till the lowest frequency limit or out of the condition of reducing frequency;

#### 3. Power turn-off

If  $[I_{\text{Phase Current}}] \geq [I_{\text{Power Turn-Off Phase Current}}]$ , the compressor phase current shall stop working for overcurrent protection; if  $[I_{\text{Phase Current}}] \leq [I_{\text{Frequency Reducing Phase Current}}]$ , and the compressor have stopped working for 3 min, the machine shall be allowed to operate;

4. If the overcurrent protection of compressor phase current continuously occurs for six times, it should not be resumed automatically, and you should press the ON/OFF button to resume. During the process of running, if the running time of compressor exceeds the [ $t_{\text{Clearing Time of Compressor Phase Current Times}}$ ] , the overcurrent protection is cleared to recount.

---

# OPERATION

## 9-24k Sequence of Operation

### (12) Starting-up Failure Protection for Compressor

Stop the compressor after starting fails, then restart it after 20s if the fault doesn't show. If starting fails 3 consecutive times, it shall be reported as Starting-up Failure, and then restart up it after 3 min. When it still not be able to operate through carry out the above process for 5 times, it is available if you press ON/OFF. The compressor should be cleared after it runs 2 min.

### (13) Out-of-Step Protection for Compressor

The out-of-step protection signal should be detected immediately after starting-up compressor, and once find the out-of-step protection signal, the out-of-step protection shall be stopped; if it can run for lasting power turn-off 3 min, the machine shall be allowed to operate. If it still can't run automatically when the out-of-step protection for compressor happens to stop working for 6 times in succession, it needs to press ON/OFF to operate. And if the running time is more than 10 min, the power turn-off times for out-of-step protection shall be cleared and recounted.

### (14) Voltage Abnormity Protection for DC Bus

To detect voltage abnormity protection for dc bus after completing the pre-charge:

#### 1. Over-High Voltage Protection for DC Bus:

If it found the DC bus voltage  $U_{DC} > [U_{DC} \text{ Jiekuangchun Protection}]$ , turn off PFC and stop the compressor at once, and it shall show the DC over-high voltage failure; it should clear out the failure when the voltage dropped to  $U_{DC} < [U_{DC} \text{ Jiekuangchun Recovery}]$  and the compressor stopped for 3 min.

#### 2. Over-Low Voltage Protection for DC Bus:

If it found the DC bus voltage  $U_{DC} < [U_{DC} \text{ Wantuochun Protection}]$ , turn off PFC and stop the compressor at once, and it shall show the DC over-low voltage; and it should clear out the failure when the voltage raised to  $U_{DC} > [U_{DC} \text{ Wantuochun Recovery}]$  and the compressor stopped for 3 min.

#### 3. To detect voltage abnormity protect for DC bus when getting electricity:

If it found the DC bus voltage  $U_{DC} > [U_{DC} \text{ Over-High Voltage}]$ , turn off the relay at once, and shows voltage abnormity failure for DC Bus. And the failure can't recover except to break off and get the electricity.

### (15) Abnormity Protection for Four-way Valve

Under the model of heating operation in good condition: the compressor is detected  $[T_{\text{Inner Tube}} < (T_{\text{Inner Ring}} - T_{\text{Abnormity Temperature Difference For Four-Way Valve Reversion}})]$ , during the running, it should be regarded as four-way valve reversion abnormity. And then it can run if stop the reversion abnormity protection for four-way valve 3 min; and if it still can't run when the reversion abnormity protection for four-way valve happens to stop working for 3 times in succession, it is available if presses ON/OFF.

Attention: the protection shall be shielded during the testing mode and defrosting process, and it shall be cleared out the failure and its times immediately when turning off or delivering wind / cooling / dehumidifying mode conversed (the inverted mode Don't clear out the failure when it can't recover to operate).

### (16) PFC Protection

1. After start up the PFC, it should detect the protection signal of PFC immediately; under the condition of PFC protection, it should turn off the PFC and compressor at the same time;
2. It shows the failure is cleared out if PFC Protection stopped working 3 min and recovers to run automatically;
3. If the PFC protection failure occurs 3 times consecutively, it will be available if you press ON/OFF; and clear the PFC Protection times when start up PFC for 10min.

### (17) Failure Detection for Sensor

1. Outdoor Ambient Sensor: detect the failure of sensor at all times.
2. Outdoor Tube Sensor: You should not detect the failure of outdoor tube sensor within 10 minutes heating operation compressor except the defrosting, and you could detect it at other time.
3. Outdoor Exhaust Sensor:
  - (a) The compressor only detect the sensor failure after it start up 3 min in normal mode;
  - (b) It should detect the exhaust sensor failure immediately in the testing mode.
4. Module Temperature Sensor:
  - (a) Short-Circuit Detection: the compressor should be detected immediately when the module temperature sensor occurs short-circuits;
  - (b) Open-Circuit Detection: the compressor should be detected on open-circuit when it runs 3min (it neednt 30s avoiding the module over-heated).
  - (c) Detect the sensor failure at all times in the testing mode.
5. Disposal for Sensor Protection
  - (1) When the short-circuit of sensor is detected within 30s, It is regarded as the temperature of sensor over-high (or infinitely high), and now according to the over-high sensor, the machine should carry out the corresponding protection to stop working, and show the corresponding temperature shutdown protection and sensor failure at the same time (for example: the compressor stops immediately when the outdoor tube sensor short-circuit, and the machine shall show the overload protection and outdoor tube sensor failure).
  - (2) When the open-circuit of sensor is detected within 30s, The protection shall be stopped and it shall show the corresponding sensor failure.

---

# OPERATION

## 9-24k Sequence of Operation

### 6. Electric Heating Function of Chassis

- (1) When  $T_{\text{outdoor amb.}} \leq 32^{\circ}\text{F}$  , the electric heating of chassis will operate;
- (2) When  $T_{\text{outdoor amb.}} > 35.6^{\circ}\text{F}$  , the electric heating of chassis will stop operation;
- (3) When  $32^{\circ}\text{F} < T_{\text{outdoor amb.}} \leq 35.6^{\circ}\text{F}$ , the electric heating of chassis will keep original status.

### 7. Electric Heating Function of Compressor

- (1) When  $T_{\text{outdoor amb.}} \leq 23^{\circ}\text{F}$  , compressor stops operation, while the electric heating of compressor starts operation;
- (2) When  $T_{\text{outdoor amb.}} > 28.4^{\circ}\text{F}$  , the electric heating of compressor stops operation;
- (3) When  $23^{\circ}\text{F} < T_{\text{outdoor amb.}} \leq 28.4^{\circ}\text{F}$  , the electric heating of compressor will keep original status.

# OPERATION

## 36k Sequence of Operation

### 1. Temperature Parameters

Indoor preset temperature ( $T_{\text{preset}}$ )

Indoor ambient temperature ( $T_{\text{amb}}$ )

### 2. Basic Functions

Once energized, in no case should the compressor be restarted within less than 3 minutes. In the situation that memory function is available, for the first energization, if the compressor is at stop before de-energization, the compressor will be started without a 3-minute lag; if the compressor is in operation before de-energization, the compressor will be started with a 3-minute lag; and once started, the compressor will not be stopped within 6 minutes regardless of changes in room temperature;

#### (1) Cooling Mode

##### ① Working conditions and process of cooling

When  $T_{\text{amb}} \geq T_{\text{preset}}$ , the unit will enter cooling operation, in which case the indoor fan, the outdoor fan and the compressor will work and the indoor fan will run at preset speed.

When  $T_{\text{amb}} \leq T_{\text{preset}} - 3.6^\circ\text{F}$ , the compressor will stop, the outdoor fan will stop with a time lag of 60s, and the indoor fan will run at preset speed.

When  $T_{\text{preset}} - 3.6^\circ\text{F} < T_{\text{amb}} < T_{\text{preset}} + 1.8^\circ\text{F}$ , the unit will remain at its previous state.

Under this mode, the four-way valve will be de-energized and temperature can be set within a range from  $61^\circ\text{F} \sim 86^\circ\text{F}$ . If the compressor is shut down for some reason, the indoor fan and the swing device will operate at original state.

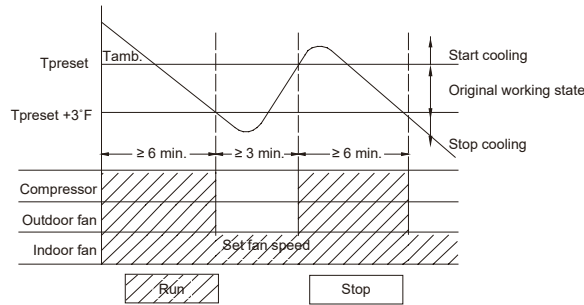

##### ② Protection

###### Antifreeze protection

Under cooling and dehumidifying mode, 6 minutes after the compressor is started:

If  $T_{\text{evap}} \leq 35.6^\circ\text{F}$ , the compressor will operate at reduced frequency.

If  $T_{\text{evap}} \leq 30.2^\circ\text{F}$  is detected for durative 3 minutes, the compressor will stop, and after 60 seconds, the outdoor fan will stop; and under cooling mode, the indoor fan and the swing motor will remain at the original state.

If  $T_{\text{evap}} \geq 42.8^\circ\text{F}$  and the compressor has remained at OFF for at least 3 minutes, the compressor will resume its original operation state.

###### Total current up and frequency down protection

If  $I_{\text{total}} \leq 16\text{A}$ , frequency rise will be allowed; if  $I_{\text{total}} \geq 17\text{A}$ , frequency rise will not be allowed; if  $I_{\text{total}} \geq 18\text{A}$ , the compressor will run at reduced frequency; and if  $I_{\text{total}} \geq 20\text{A}$ , the compressor will stop and the outdoor fan will stop with a time lag of 60s.

#### (2) Dehumidifying Mode

##### ① Working conditions and process of dehumidifying.

If  $T_{\text{amb}} > T_{\text{preset}} + 1.8^\circ\text{F}$ , the unit will enter cooling and dehumidifying mode, in which case the compressor and the outdoor fan will operate and the indoor fan will run at low speed.

If  $T_{\text{preset}} - 3.6^\circ\text{F} \leq T_{\text{amb}} \leq T_{\text{preset}} + 1.8^\circ\text{F}$ , the compressor remains at its original operation state.

If  $T_{\text{amb}} < T_{\text{preset}} - 3.6^\circ\text{F}$ , the compressor will stop, the outdoor fan will stop with a time lag of 60s, and the indoor fan will operate at low speed.

##### ② Protection

Protection is the same as that under the cooling mode.

#### (3) Heating Mode

##### ① Working conditions and process of heating

If  $T_{\text{amb}} \leq T_{\text{preset}} + 3.6^\circ\text{F}$ , the unit enters heating mode, in which case the four-way valve, the compressor and the outdoor fan will operate simultaneously, and the indoor fan will run at preset speed in the condition of preset cold air prevention.

If  $T_{\text{amb}} \geq T_{\text{preset}} + 9^\circ\text{F}$ , the compressor will stop, the outdoor fan will stop with a time lag of 60s, and the indoor fan will stop after 60-second blow at low speed.

If  $T_{\text{preset}} + 3.6^\circ\text{F} < T_{\text{amb}} < T_{\text{preset}} + 9^\circ\text{F}$ , the unit will maintain its original operating status.

Under this mode, the four-way valve is energized and temperature can be set within a range of  $61^\circ\text{F} \sim 86^\circ\text{F}$ . The operating symbol, the heating symbol and preset temperature are revealed on the display.

##### ② Condition and process of defrost

# OPERATION

## 36k Sequence of Operation

When duration of successive heating operation is more than 45 minutes, or accumulated heating time more than 90 minutes, and one of the following conditions is reached, the unit will enter the defrost mode after 3 minutes.

- a.  $T_{\text{outdoor amb.}} \geq 41^{\circ}\text{F}$ ,  $T_{\text{outdoor pipe}} \leq 28.4^{\circ}\text{F}$ ; b.  $28.4^{\circ}\text{F} \leq T_{\text{outdoor amb.}}$
- c.  $23.4^{\circ}\text{F} < T_{\text{outdoor amb.}} \leq 28.4^{\circ}\text{F}$ ,  $T_{\text{outdoor pipe}} \leq 17.6^{\circ}\text{F}$ ;
- d.  $14^{\circ}\text{F} < T_{\text{outdoor amb.}} < 23^{\circ}\text{F}$ ,  $T_{\text{outdoor pipe}} - T_{\text{compensation}} \leq T_{\text{outdoor amb.}} - 5.4^{\circ}\text{F}$ ;
- e.  $T_{\text{outdoor amb.}} < 14^{\circ}\text{F}$ ,  $T_{\text{outdoor pipe}} - T_{\text{compensation}} \leq T_{\text{outdoor amb.}} - 5.4^{\circ}\text{F}$ ;

After energization, when defrosting for the first time  $T_{\text{compensation}} = 0^{\circ}\text{F}$ . If it is not the first time for defrosting, the  $T_{\text{compensation}}$  is determined by the  $T_{\text{outdoor pipe}}$  of last time quitting defrosting.

- a.  $T_{\text{outdoor pipe}} > 35.6^{\circ}\text{F}$ ,  $T_{\text{compensation}} = 0^{\circ}\text{F}$ ; b.  $T_{\text{outdoor pipe}} \leq 35.6^{\circ}\text{F}$ ,  $T_{\text{compensation}} = 5.4^{\circ}\text{F}$ .

At that time, the indoor fan stops and the compressor stops, and after 60 seconds the outer fan will stop, and then after 30 seconds, the four-way valve will stop. After 30 seconds, the compressor is initiated for raising the frequency to defrost frequency.

When the compressor has operated under defrost mode for 10 minutes, or  $T_{\text{outdoor tube}} \geq 50^{\circ}\text{F}$ , the compressor will be converted to 46Hz operation. After 30 seconds, the compressor will stop. And after another 30 seconds, the four-way valve will be opened, and after 60 seconds, the compressor and the outer fan will be started, the indoor fan will run under preset cold air prevention conditions, and H1 will be displayed at temperature display area on the display panel. Defrost frequency is 70 Hz.

### 3. Protection

#### Cold air prevention

The unit is started under heating mode (the compressor is ON):

① In the case of  $T_{\text{indoor amb.}} < 75^{\circ}\text{F}$ : if  $T_{\text{tube}} \leq 104^{\circ}\text{F}$  and the indoor fan is at stop state, the indoor fan will begin to run at low speed with a time lag of 2 minutes. Within 2 minutes, if  $T_{\text{tube}} > 104^{\circ}\text{F}$ , the indoor fan also will run at low speed; and after 1 minute operation at low speed, the indoor fan will be converted to operation at preset speed. Within 1 minute low speed operation or 2 minute non-operation, if  $T_{\text{tube}} > 108^{\circ}\text{F}$ , the fan will run at present speed.

② In the case of  $T_{\text{indoor amb.}} < 75^{\circ}\text{F}$ : if  $T_{\text{tube}} \leq 108^{\circ}\text{F}$ , the indoor fan will run at low speed, and after one minute, the indoor fan will be converted to preset speed. Within 1 minute low speed operation, if  $T_{\text{tube}} > 104^{\circ}\text{F}$ , the indoor fan will be converted to preset speed. Note:  $T_{\text{indoor amb.}}$  indicated in ① and ② refers to, under initially heating mode, the indoor ambient temperature before the command to start the compressor is performed according to the program, or after the unit is withdrawn from defrost, the indoor ambient temperature before the defrost symbol is cleared.

#### Total current up and frequency down protection

If the total current  $I_{\text{total}} \leq 16\text{A}$ , frequency rise will be allowed; if  $I_{\text{total}} \geq 17\text{A}$ , frequency rise will not be allowed; if  $I_{\text{total}} \geq 18\text{A}$ , the compressor will run at reduced frequency; and if  $I_{\text{total}} \geq 20\text{A}$ , the compressor will stop and the outdoor fan will stop with a time lag of 60s.

#### (4) Fan Mode

Under the mode, the indoor fan will run at preset speed and the compressor, the outdoor fan, the four-way valve and the electric heater will stop.

Under the mode, temperature can be set within a range of  $61^{\circ}\text{F} \sim 86^{\circ}\text{F}$ .

#### (5) AUTO Mode

##### ① Working conditions and process of AUTO mode

Under AUTO mode, standard cooling temperature  $T_{\text{preset}}$  is  $77^{\circ}\text{F}$  and standard heating temperature  $T_{\text{preset}}$  is  $68^{\circ}\text{F}$ .

a. Once energized, if  $T_{\text{amb.}} \leq 71.6^{\circ}\text{F}$ , the unit will be started under heating mode; if  $71.6^{\circ}\text{F} < T_{\text{amb.}} < 78.8^{\circ}\text{F}$ , the unit will run under fan mode and the run indicator will be bright; and if  $T_{\text{amb.}} \geq 78.8^{\circ}\text{F}$ , the unit will be started under cooling mode.

b. Under AUTO mode, if  $T_{\text{amb.}} \geq T_{\text{preset}} + 1.8^{\circ}\text{F}$  is detected, the unit will select to run under cooling mode, in which case implicit preset temperature is  $77^{\circ}\text{F}$ ; if  $T_{\text{amb.}} \leq T_{\text{preset}} - 1.8^{\circ}\text{F}$ , the compressor will stop, the outdoor fan will stop with a time lag of 1 minute, and the indoor fan will run at preset speed; and if  $T_{\text{preset}} - 1.8^{\circ}\text{F} < T_{\text{amb.}} < T_{\text{preset}} + 1.8^{\circ}\text{F}$ , the unit will remain at its original state.

c. Under AUTO mode, if  $T_{\text{amb.}} \leq T_{\text{preset}} + 3.6^{\circ}\text{F}$  is detected, the unit will select to run under heating mode, in which case implicit preset temperature is  $64^{\circ}\text{F}$ ; if  $T_{\text{amb.}} \geq T_{\text{preset}} + 9^{\circ}\text{F}$ , the compressor will stop, the outdoor fan will stop with a time lag of 1 minute, and the indoor fan will run under the mode of residue heat blowing; and if  $T_{\text{preset}} + 3.6^{\circ}\text{F} < T_{\text{amb.}} < T_{\text{preset}} + 41^{\circ}\text{F}$ , the unit will remain at its original state. The cooling-only unit will run under fan mode.

d. Under AUTO mode, if  $71.6^{\circ}\text{F} < T_{\text{amb.}} < 78.8^{\circ}\text{F}$ , the unit will remain at its original state.

##### ② Protection

a. In cooling operation, protection is the same as that under the cooling mode;

b. In heating operation, protection is the same as that under the heating mode;

c. When ambient temperature changes, operation mode will be converted preferentially. Once started, the compressor will remain unchanged for at least 6 minutes.

#### (6) Common Protection Functions and Fault Display under COOL, HEAT, DRY and AUTO Modes

##### ① Overload protection

$T_{\text{tube}}$ : measured temperature of outdoor heat exchanger under cooling mode; and measured temperature of indoor heat exchanger under heating mode.

##### 1) Cooling overload.

a. If  $T_{\text{tube}} \leq 126^{\circ}\text{F}$ , the unit will return to its original operation state.

b. If  $T_{\text{tube}} \geq 131^{\circ}\text{F}$ , frequency rise is not allowed.

# OPERATION

## 36k Sequence of Operation

- c. If  $T_{tube} \geq 136^{\circ}\text{F}$ , the compressor will run at reduced frequency.
- d. If  $T_{tube} \geq 144^{\circ}\text{F}$ , the compressor will stop and the indoor fan will run at preset speed.

### 2) Heating overload

- a. If  $T_{tube} \leq 126^{\circ}\text{F}$ , the unit will return to its original operation state.
- b. If  $T_{tube} \geq 131^{\circ}\text{F}$ , frequency rise is not allowed.
- c. If  $T_{tube} \geq 136^{\circ}\text{F}$ , the compressor will run at reduced frequency.
- d. If  $T_{tube} \geq 144^{\circ}\text{F}$ , the compressor will stop and the indoor fan will blow residue heat and then stop.

### ② Exhaust temperature protection of compressor

If exhaust temperature  $\geq 208^{\circ}\text{F}$ , frequency is not allowed to rise.

If exhaust temperature  $\geq 217^{\circ}\text{F}$ , the compressor will run at reduced frequency.

If exhaust temperature  $\geq 230^{\circ}\text{F}$ , the compressor will stop.

If exhaust temperature  $\leq 194^{\circ}\text{F}$ , the compressor has stayed at stop for at least 3 minutes, the compressor will resume its operation.

### ③ Communication fault

If the unit fails to receive correct signals for durative 3 minutes, communication fault can be justified and the whole system will stop.

### ④ Module protection

Under module protection mode, the compressor will stop. When the compressor remains at stop for at least 3 minutes, the compressor will resume its operation. If module protection occurs six times in succession, the compressor will not be started again.

### ⑤ Overload protection

If temperature sensed by the overload sensor is over  $239^{\circ}\text{F}$ , the compressor will stop and the outdoor fan will stop with a time lag of 30 seconds. If temperature is below  $203^{\circ}\text{F}$ , the overload protection will be relieved.

If voltage on the DC bus is below 150V or over 420V, the compressor will stop and the outdoor fan will stop with a timelag of 30 seconds.

When voltage on the DC bus returns to its normal value and the compressor has stayed at stop for at least 3 minutes, the compressor will resume its operation.

### ⑥ Faults of temperature sensors

| Designation of sensors      | Faults  |
|-----------------------------|---|
| Indoor ambient temperature  | The sensor is detected to be open-circuited or short-circuited for successive 5 seconds   |
| Indoor tube temperature     | The sensor is detected to be open-circuited or short-circuited for successive 5 seconds   |
| Outdoor ambient temperature | The sensor is detected to be open-circuited or short-circuited for successive 30 seconds  |
| Outdoor tube temperature    | The sensor is detected to be open-circuited or short-circuited for successive 30 seconds, and no detection is performed within 10 minutes after defrost begins. |
| Exhaust                     | After the compressor has operated for 3 minutes, the sensor is detected to be open-circuited or short-circuited for successive 30 seconds.                      |
| Overload                    | After the compressor has operated for 3 minutes, the sensor is detected to be open-circuited or short-circuited for successive 30 seconds.                      |



# OPERATION

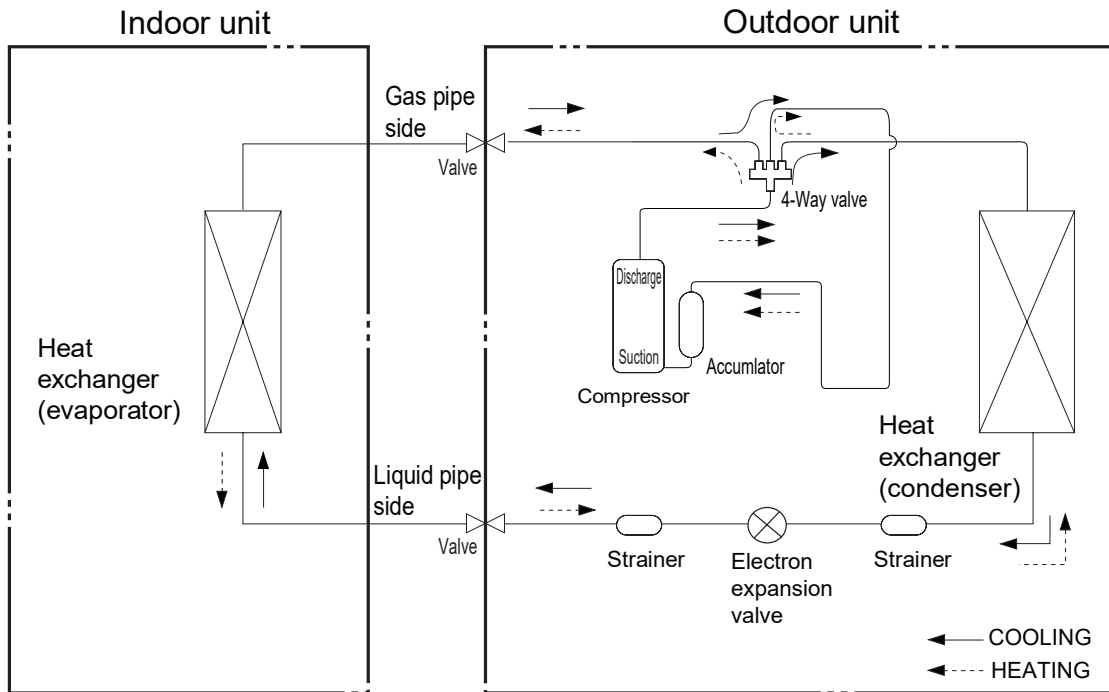

Figure 302

**9-12K Refrigerant System Diagram**

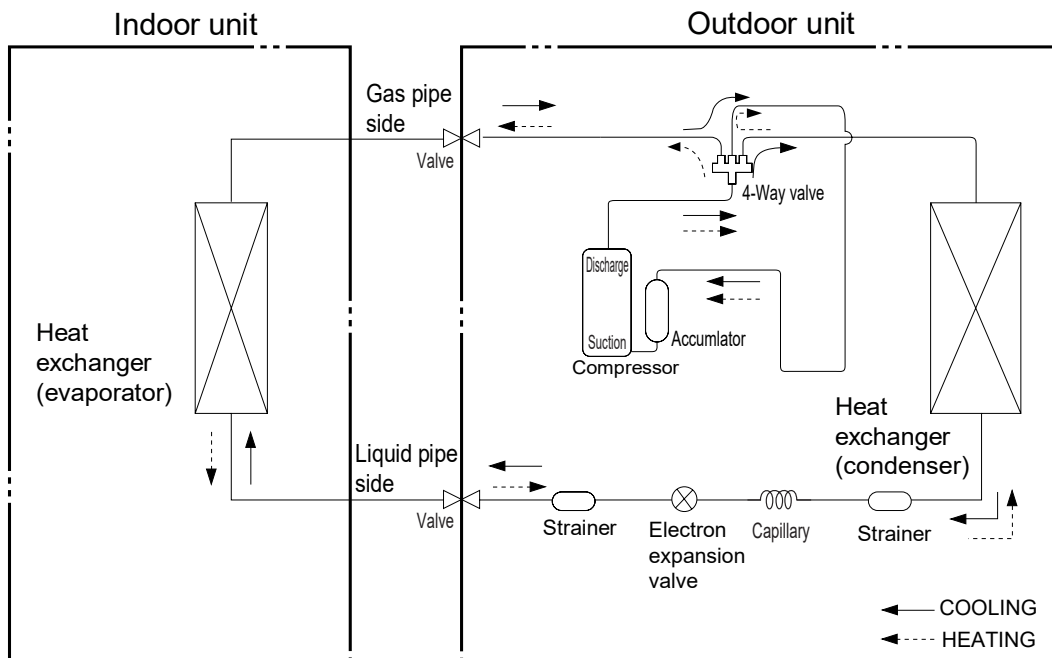
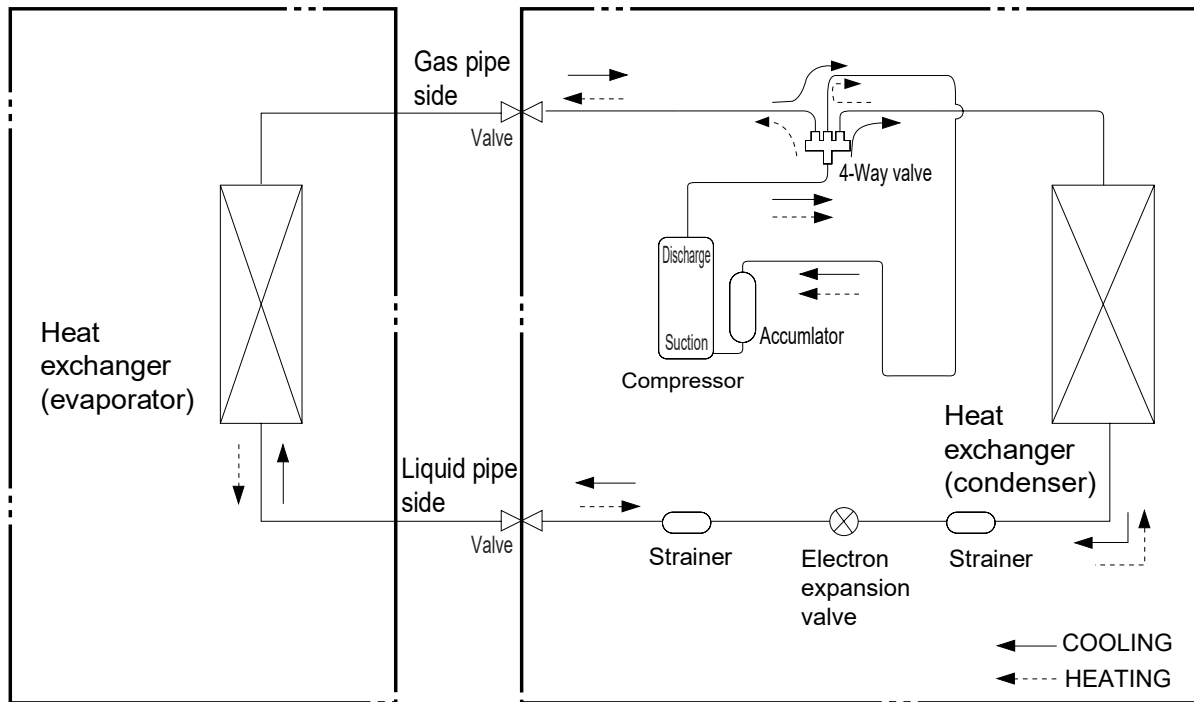

Figure 303

**18-24K Refrigerant System Diagram**

# OPERATION



Connection pipe specification:

Liquid pipe: 1/4 inch

Gas pipe: 5/8 inch

Figure 304

**36K Refrigerant System Diagram**

---

# INSTALLATION

## Safety Precautions: Important!

Please read the safety precautions carefully before installation and maintenance.  
The following contents are very important for installation and maintenance.

Please follow the instructions below.

- The installation or maintenance must accord with the instructions.
- Comply with all national electrical codes and local electrical codes.
- Pay attention to the warnings and cautions in this manual.
- All installation and maintenance shall be performed by distributor or qualified person.
- All electric work must be performed by a licensed technician according to local regulations and the instructions given in this manual.
- Be caution during installation and maintenance. Prohibit incorrect operation to prevent electric shock, casualty and other accidents.



## Warnings

---

### Electrical Safety Precautions:

1. Cut off the power supply of air conditioner before checking and maintenance.
2. The air condition must apply specialized circuit and prohibit share the same circuit with other appliances.
3. The air conditioner should be installed in suitable location and ensure the power plug is touchable.
4. Make sure each wiring terminal is connected firmly during installation and maintenance.
5. Have the unit adequately grounded. The grounding wire can't be used for other purposes.
6. Must apply protective accessories such as protective boards, cable-cross loop and wire clip.
7. The live wire, neutral wire and grounding wire of power supply must be corresponding to the live wire, neutral wire and grounding wire of the air conditioner.
8. The power cord and power connection wires can't be pressed by hard objects.
9. If power cord or connection wire is broken, it must be replaced by a qualified person.

10. If the power cord or connection wire is not long enough, please get the specialized power cord or connection wire from the manufacture or distributor. Prohibit prolong the wire by yourself.
11. For the air conditioner without plug, an air switch must be installed in the circuit. The air switch should be all-pole parting and the contact parting distance should be more than 1/8 inch.
12. Make sure all wires and pipes are connected properly and the valves are opened before energizing.
13. Check if there is electric leakage on the unit body. If yes, please eliminate the electric leakage.
14. Replace the fuse with a new one of the same specification if it is burnt down; don't replace it with a cooper wire or conducting wire.
15. If the unit is to be installed in a humid place, the circuit breaker must be installed.

### Installation Safety Precautions:

1. Select the installation location according to the requirement of this manual.(See the requirements in installation part)
2. Handle unit transportation with care; the unit should not be carried by only one person if it is more than 44.09lb.
3. When installing the indoor unit and outdoor unit, a sufficient fixing bolt must be installed; make sure the installation support is firm.
4. Ware safety belt if the height of working is above 78 3/4 inch.
5. Use equipped components or appointed components during installation.
6. Make sure no foreign objects are left in the unit after finishing installation.

### Refrigerant Safety Precautions:

1. Avoid contact between refrigerant and fire as it generates poisonous gas; Prohibit prolong the connection pipe by welding.
2. Apply specified refrigerant only. Never have it mixed with any other refrigerant. Never have air remain in the refrigerant line as it may lead to rupture or other hazards.
3. Make sure no refrigerant gas is leaking out when installation is completed.
4. If there is refrigerant leakage, please take sufficient measure to minimize the density of refrigerant.
5. Never touch the refrigerant piping or compressor without wearing glove to avoid scald or frostbite.

Improper installation may lead to fire hazard, explosion, electric shock or injury.

# INSTALLATION

## Installation Tools

|  |   |  |
|--|---|--|
| <p>1. Level meter, measuring tape</p>   | <p>2. Screw driver</p>                   | <p>3. Impact drill, drill head, electric drill</p>               |
| <p>4. Electroprobe</p>                  | <p>5. Universal meter</p>                | <p>6. Torque wrench, open-end wrench, inner hexagon spanner</p>  |
| <p>7. Electronic leakage detector</p>  | <p>8. Vacuum pump</p>                  | <p>9. Pressure meter</p>                                        |
| <p>10. Pipe pliers, pipe cutter</p>   | <p>11. Pipe expander, pipe bender</p>  | <p>12. Soldering appliance, refrigerant container</p>          |

# INSTALLATION

## Installation Dimension Diagram

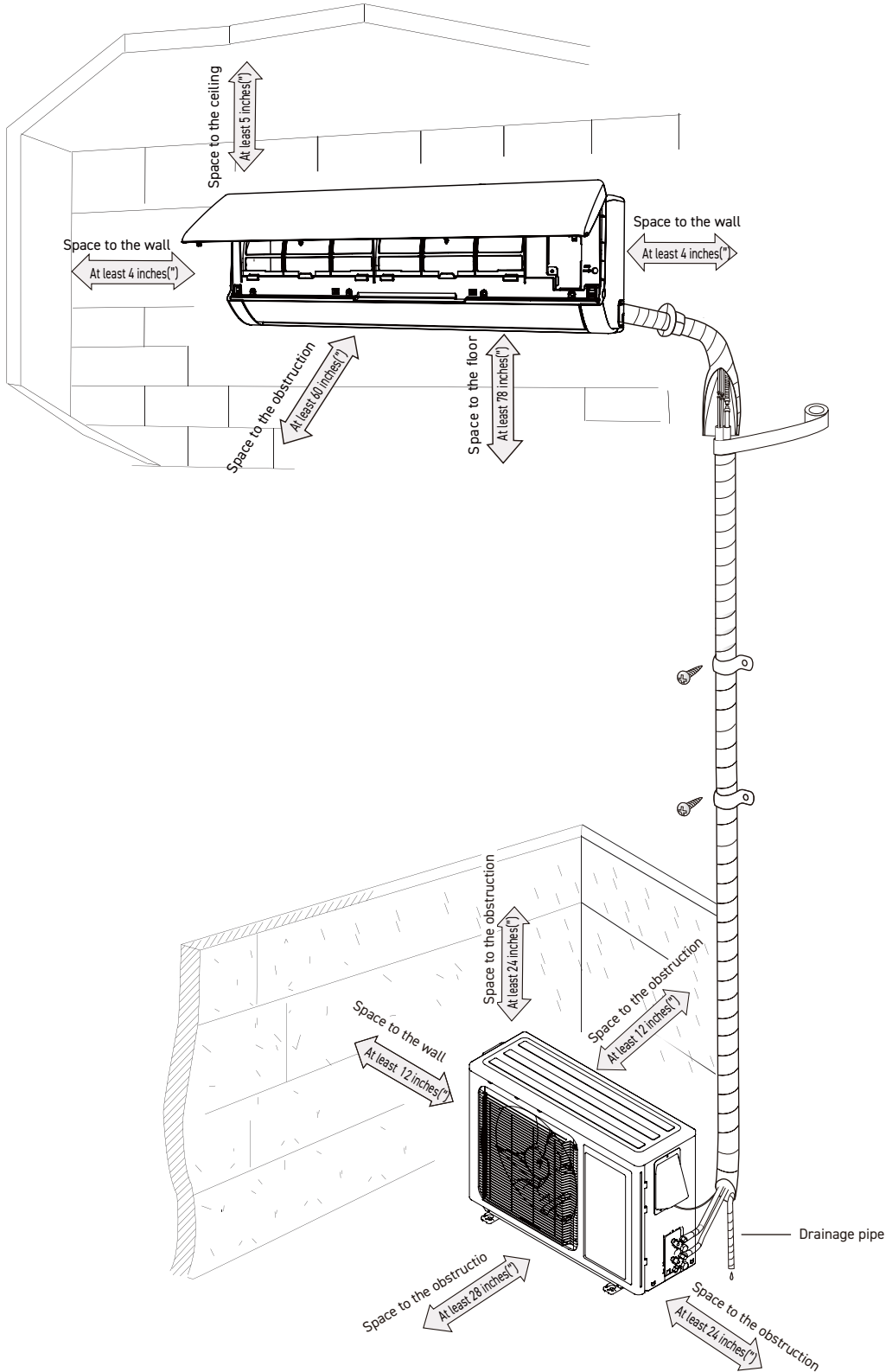

# INSTALLATION

## Installation Work Flow

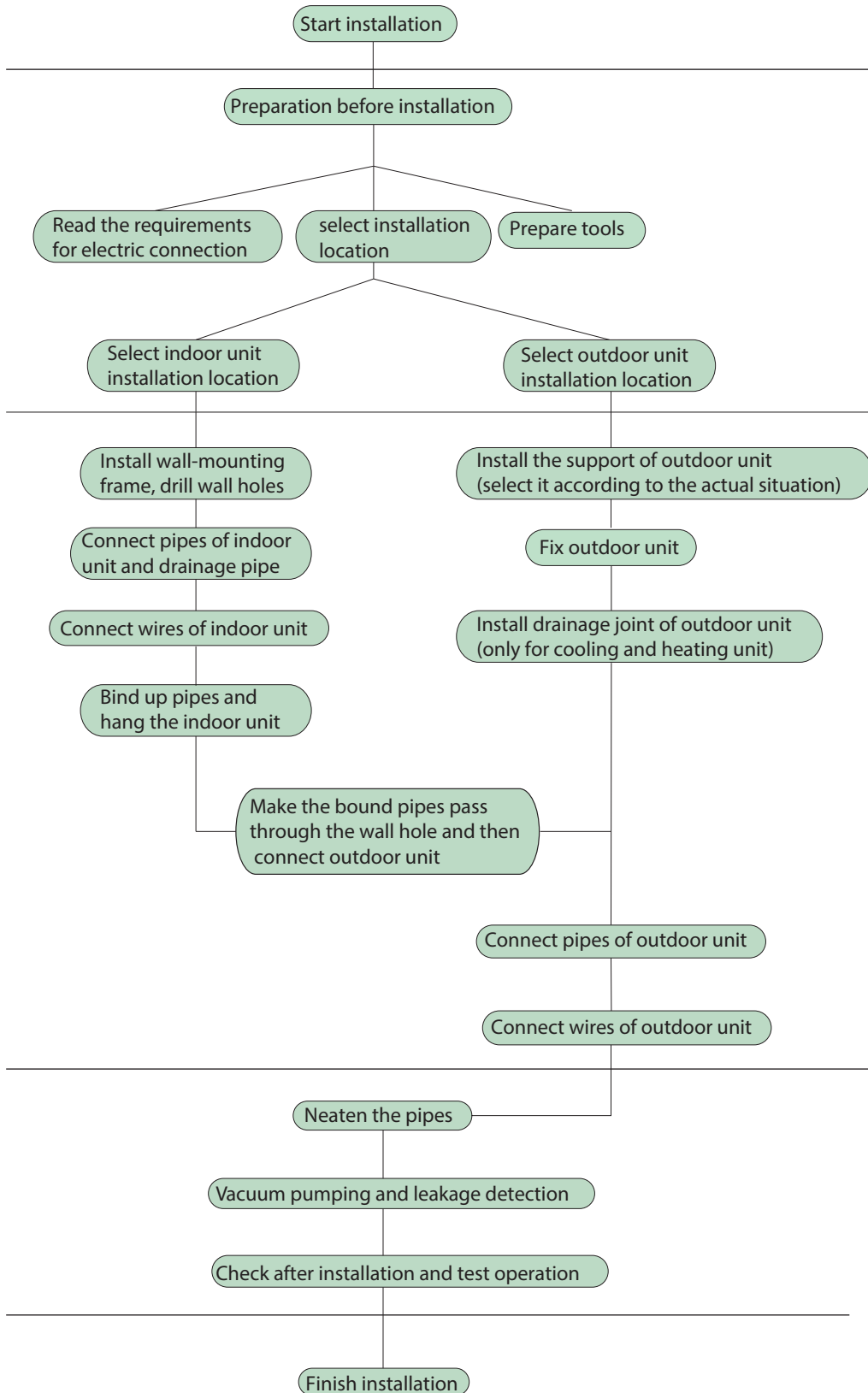

---

# INSTALLATION

## Installation Parts Checklist

1. Indoor Unit
2. Outdoor Unit
3. Connection Pipe
4. Drainage pipe
5. Wall Mounting Frame
6. Connecting Cable (power cord)
7. Wall Pipe
8. Sealing gim
9. Wrapping Tape
10. Outdoor unit support
11. Fixing screw
12. Drainage plug (cooling and heating unit)
13. Owner's Manual
14. Remote Control

## Selection of Installation Location

### Basic Requirement

Installing the unit in the following places may cause malfunction. If it is unavoidable, please consult the local dealer:

1. Places with strong heat sources, vapors, flammable or explosive gas, or volatile objects spread in the air.
2. Places with high-frequency devices (such as welding machine, medical equipment).
3. Places with oil or fumes in the air.
4. Places with sulfureted gas.

### Indoor Unit

1. There should be no obstruction near air inlet and air outlet.
2. Select a location where the condensation water can be dispersed easily and won't affect other people.
3. Select a location which is convenient to connect the outdoor unit and near the power socket.
4. Select a location which is out of reach for children.
5. The location should be able to withstand the weight of indoor unit and won't increase noise and vibration.
6. The appliance must be installed 78 inches above the floor.
7. Don't install the indoor unit right above electric appliances.
8. The appliance shall not be installed in the laundry.

---

# INSTALLATION

## Outdoor Unit

1. Select a location where the noise and outflow air emitted by the outdoor unit will not affect neighborhood.
2. The location should be well ventilated and dry, in which the outdoor unit won't be exposed directly to sunlight or strong wind.
3. The location should be able to withstand the weight of outdoor unit.
4. Make sure that the installation follows the requirement of installation dimension diagram.
5. Select a location which is out of reach for children and far away from animals or plants. If it is unavoidable, please add fence for safety purpose.

## Electrical connection Requirements

### Safety Precaution

1. Must follow the electric safety regulations when installing the unit.
2. According to the local safety regulations, use qualified power supply circuit and air switch.
3. Make sure the power supply matches with the requirement of air conditioner. Unstable power supply or incorrect wiring may result in electric shock, fire hazard or malfunction. Please install proper power supply cables before using the air conditioner.
4. Properly connect the live wire, neutral wire and grounding wire of power socket.
5. Be sure to cut off the power supply before proceeding any work related to electricity and safety.
6. Do not put through the power before finishing installation.
7. For appliances with type Y attachment, the instructions shall contain the substance of the following. If the supply cord is damaged, it must be replaced by the manufacturer, its service agent or similarly qualified persons in order to avoid a hazard.
8. The temperature of refrigerant circuit will be high, please keep the interconnection cable away from the copper tube.

### Grounding Requirements

1. The air conditioner is first class electric appliance. It must be properly grounded with a specialized grounding device by a professional. Please make sure it is always grounded effectively, otherwise it may cause electric shock.
2. The yellow-green wire in air conditioner is grounding wire, which can't be used for other purposes.
3. The grounding resistance should comply with national electric safety regulations.
4. The appliance must be positioned so that the plug is accessible.
5. An all-pole disconnection switch having a contact separation of at least 3mm in all poles should be connected in fixed wiring.
6. Include an air switch with suitable capacity, please note the following table. Air switch should be included mag net buckle and heating buckle function, it can protect the circuit-short and overload.

## CAUTION

Do not rely on the fuse alone for protection of the circuit



# INSTALLATION

## Installation of Indoor Unit

### Install Wall Mounting Frame

1. Hang the wall-mounting frame on the wall; adjust it in horizontal position with the level meter and then point out the screw fixing holes on the wall.
2. Drill the screw fixing holes on the wall with impact drill (the specification of drill head should be the same as the plastic expansion particle) and then fill the plastic expansion particles in the holes.
3. Fix the wall-mounting frame on the wall with tapping screws (ST4.2X25TA) and then check if the frame is firmly installed by pulling the frame. If the plastic expansion particle is loose, please drill another fixing hole nearby.
4. Choose the position of piping hole according to the direction of outlet pipe. The position of piping hole should be a little lower than the wall-mounted frame.(As show in Fig.1)
5. Open a piping hole with the diameter of 2 3/4inch on the selected outlet pipe position.In order to drain smoothly, slant the piping hole on the wall slightly downward to the outdoor side with the gradient of 5-10°.(As show in Fig.2)

#### Note:

1. Pay attention to dust prevention and take relevant safety measures when opening the hole.
2. The plastic expansion particles are not provided and should be bought locally.

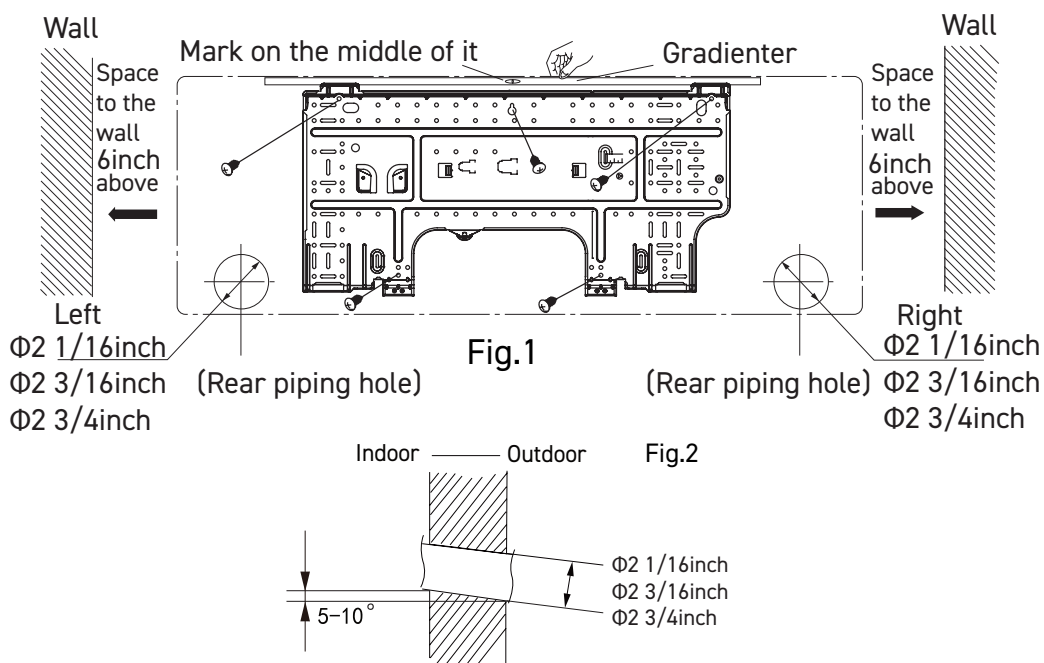

### Outlet Pipe

1. The pipe can be led out in the direction of right, rear right, left or rear left.(As show in Fig.3)
2. When selecting leading out the pipe from left or right, please cut off the corresponding hole on the bottom case.(As show in Fig.4)

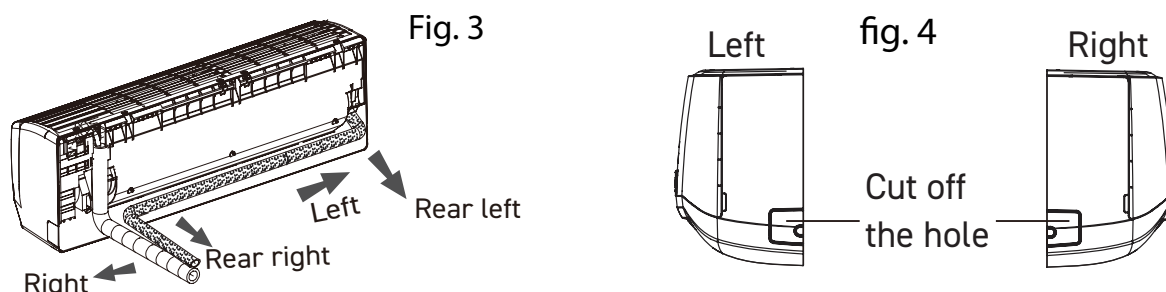

# INSTALLATION

## Installation of Indoor Unit

Connect the Pipe of the Indoor Unit

1. Aim the pipe joint at the corresponding bellmouth.(As show in Fig.5)
2. Pretightening the union nut with hand.
3. Adjust the torque force by referring to Figure 22a. Place the open-end wrench on the pipe joint and place the torque wrench on the union nut. Tighten the union nut with torque wrench.(As show in Fig.6)
4. Wrap the indoor pipe and joint of connection pipe with insulating pipe, and then wrap it with tape.(As show in Fig.7)

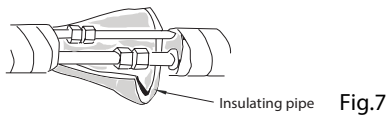
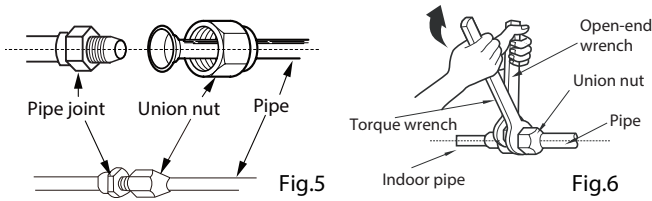

## Install Drain Hose

1. Connect the drain hose to the outlet pipe of indoor unit.(As show in Fig.8)
  2. Bind the joint with tape.(As show in Fig.9)
- Note:
1. Add insulating pipe in the indoor drain hose in order to prevent condensation. (As show in Fig.10)
  2. The plastic expansion particles are not provided.

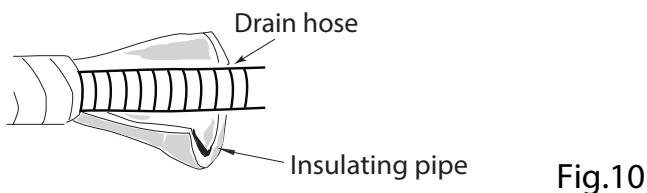
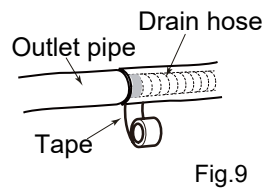
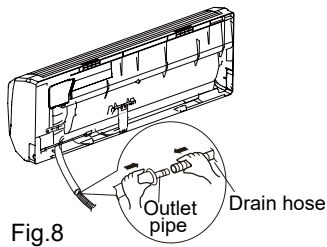

# INSTALLATION

## Installation of Indoor Unit

### Connect Wire of Indoor Unit

1. Open the panel, remove the screw on the wiring cover and then take down the cover.(As show in Fig.11)
2. Fix the wire crossing board on connection wire sleeve at the bottom case; let the connection wire sleeve go through the wire crossing hole at the back of indoor unit, and then pull it out from the front.(As show in Fig.12)

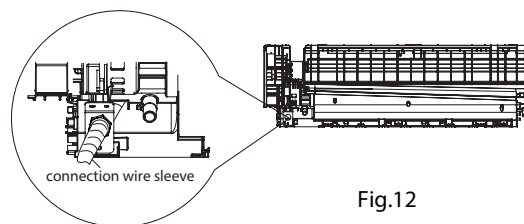
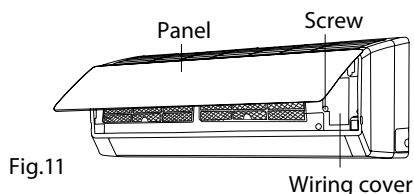

3. Remove the wire clip; connect the power connection wire to the wiring terminal; tighten the screw and then fix the power connection wire with wire clip.(As show in Fig.13)
4. Put wiring cover back and then tighten the screw.
5. Close the panel.

### NOTE:

All wires of indoor unit and outdoor unit should be connected by a professional.

If the length of power connection wire is insufficient, please contact the supplier for a new one. Avoid extending the wire by yourself.

For the air conditioner with plug, the plug should be reachable after finishing installation.

For the air conditioner without plug, an air switch must be installed in the line. The air switch should be all-pole parting and the contact parting distance should be more than 1/8inch.

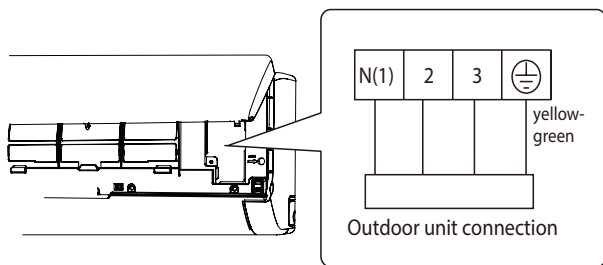

Fig.13

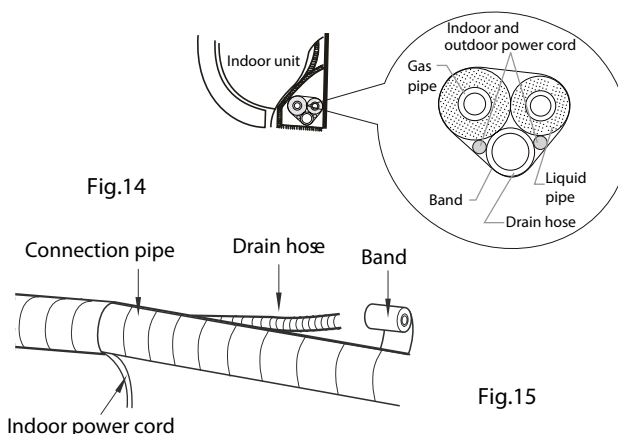

Fig.15

### Bind Up Pipe

1. Bind up the connection pipe, power cord and drain hose with the band.(As show in Fig.14)
2. Reserve a certain length of drain hose and power cord for installation when binding them. When binding to a certain degree, separate the indoor power and then separate the drain hose.(As show in Fig.15)
3. Bind them evenly.
4. The liquid pipe and gas pipe should be bound separately at the end.
5. The power cord and control wire can't be crossed or winding.
6. The drain hose should be bound at the bottom.

---

# INSTALLATION

## Installation of Indoor Unit

### Hang the Indoor Unit

1. Put the bound pipes in the wall pipe and then make them pass through the wall hole.
2. Hang the indoor unit on the wall-mounting frame.
3. Stuff the gap between pipes and wall hole with sealing gum.
4. Fix the wall pipe. (As show in Fig.16)
5. Check if the indoor unit is installed firmly and closed to the wall.(As show in Fig.17)

### NOTE

Do not bend the drain hose too excessively in order to prevent blocking.

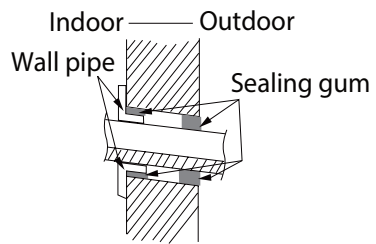

Fig.16

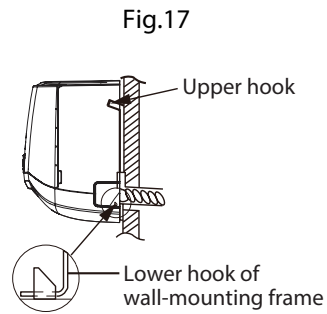

Fig.17

# INSTALLATION

## Installation of the Outdoor Unit

Install the Outdoor Support

1. Select installation location according to the house structure.
2. Fix the support of outdoor unit on the selected location with expansion screws.

Notes

1. Take sufficient protective measures when installing the outdoor unit.
2. Make sure the support can withstand at least four times the unit weight.
3. The outdoor unit should be installed at least 1 1/6inch above the floor in order to install drain joint.(As show in

Fig.18)

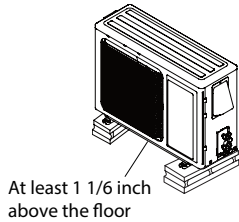

Fig.18

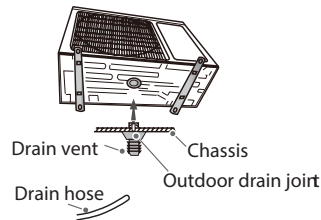

Fig.19

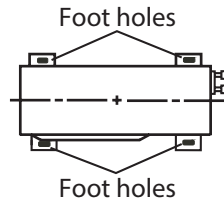

Fig.20

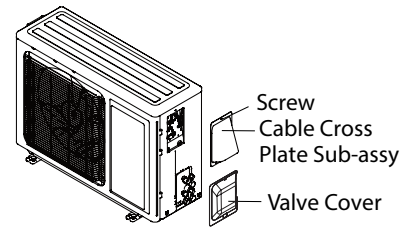

Fig.21

Install Drain Joint ( For Colling and Heating Unit Only)

1. Connect the outdoor drain joint into the hole on the chassis.
2. Connect the drain hose into the drain vent. (As show in Fig.19)

Fix the Outdoor Unit

1. Place the outdoor unit on the support.
2. Fix the foot holes of outdoor unit with bolts.(As show in Fig.20)

Connect Indoor and Outdoor Pipes

1. Remove the screw on the right cable cross plate sub-assy and valve cover of outdoor unit and then remove the cable cross plate sub-assy and valve cover.(As show in Fig.21)
2. Remove the screw cap of valve and aim the pipe joint at the bellmouth of pipe.(As show in Fig.22)
3. Pretightening the union nut with hand.
4. Tighten the union nut with torque wrench .

Refer to the figure 22a for wrench moment of force

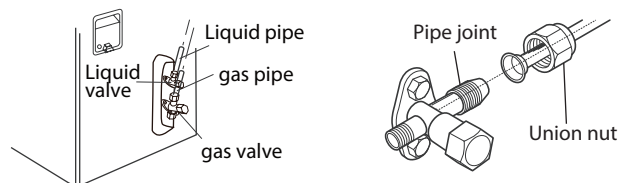

Fig.22

| Hex nut diameter(inch) | Tightening torque(ft·lbf) |
|------------------------|---------------------------|
| Φ1/4                   | 11~14.7                   |
| Φ3/8                   | 22.8~29.5                 |
| Φ1/2                   | 33.2~40.6                 |
| Φ5/8                   | 44.3~47.9                 |
| Φ3/4                   | 51.6~55.3                 |

Fig. 22a

# INSTALLATION

## Installation of the Outdoor Unit

### Connect Outdoor Electric Wire

1. Put power connection wire and power wire through the wire-passing hole.
2. Remove the wire clip; connect the power connection wire and power wire to the wiring terminal; fix them with screws.(As show in Fig.23)
3. Fix the power connection wire and power wire with wire clip.
4. Install the cable cross plate sub-assy.

### Notes

1. After tightening the screw, pull the power cord slightly to check if it is firm.
2. Never cut the power connection wire to prolong or shorten the distance.
3. The connecting wire and connection pipe cannot touch each other.
4. Top cover of outdoor unit and electric box assembly should be fixed by the screw. Otherwise, it can cause a fire, or short circuit caused by water or dust.

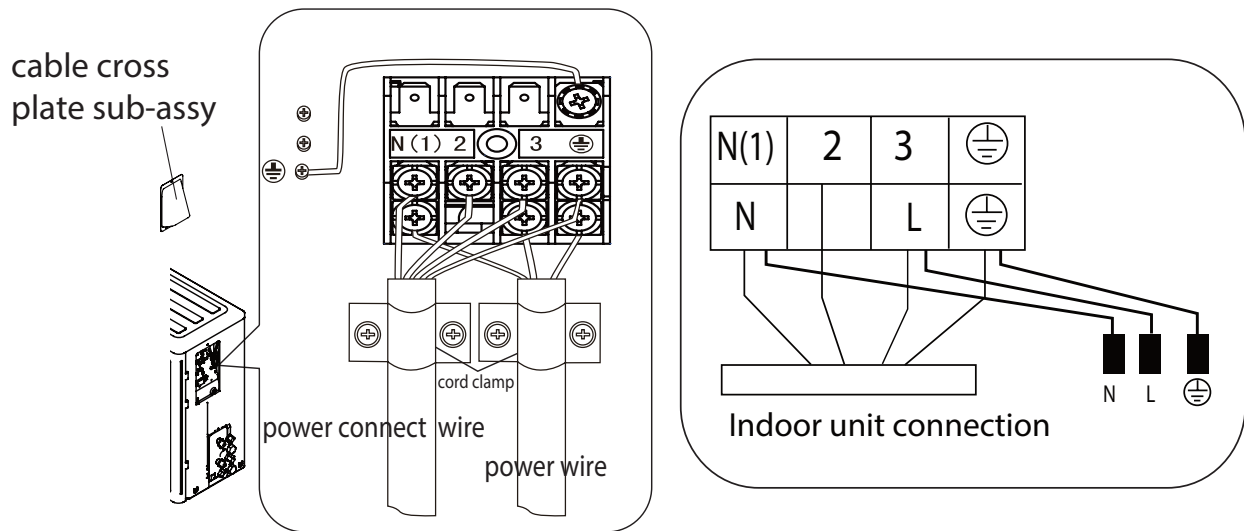
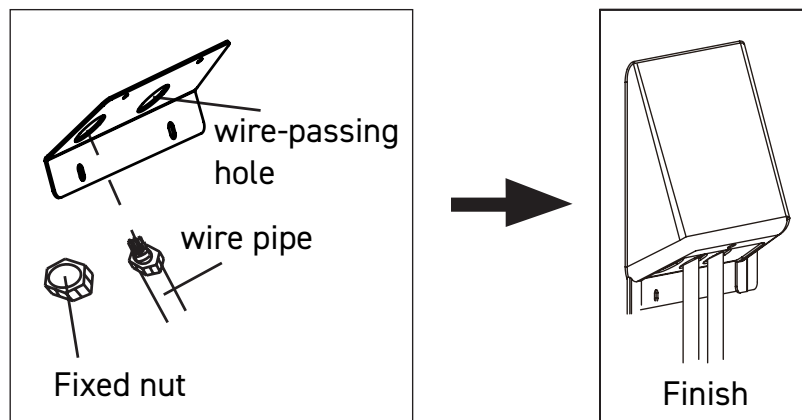

Fig.23



# INSTALLATION

## Installation of the Outdoor Unit

### Neaten the Pipes

1. The pipes should be placed along the wall, bent reasonably and hidden possibly. Min. semidiameter of bending the pipe is 4 inch.
2. If the outdoor unit is higher than the wall hole, you must set a U-shaped curve in the pipe before pipe goes into the room, in order to prevent rain from getting into the room. (As show in Fig.24)

### Notes:

1. The through-wall height of drain hose shouldn't be higher than the outlet pipe hole of indoor unit. (As show in Fig.25)
2. Slant the drain hose slightly downwards. The drain hose can't be curved, raised and fluctuant, etc. (As show in Fig.26)
3. The water outlet can't be placed in water in order to drain smoothly.(As show in Fig.27)

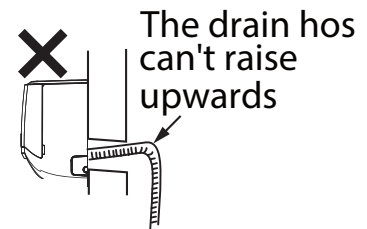
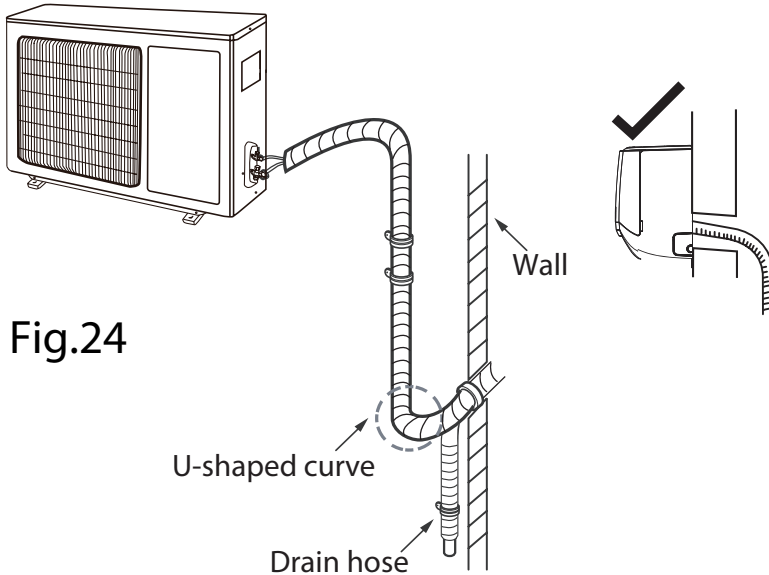

Fig.25

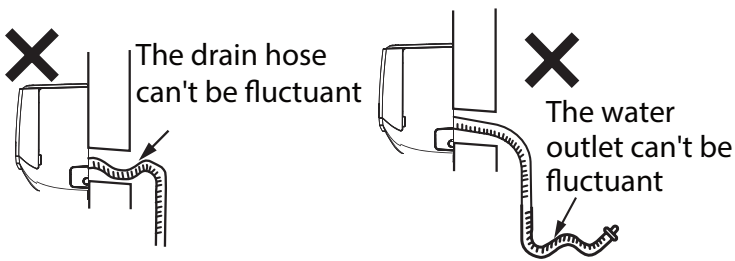
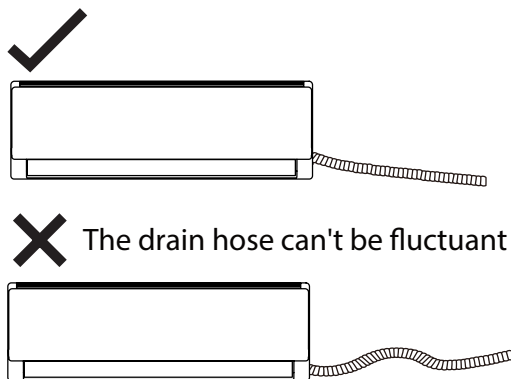

Fig.26

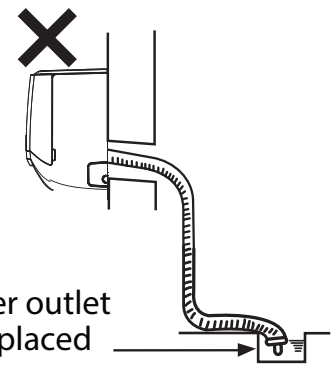

Fig.27

---

# INSTALLATION

## Leak Check, Evacuation, and Charging (Triple Evacuation)

Friedrich requires all installations are Leak Checked and Evacuated in accordance to the "triple evacuation" process. This process promotes a dry tight refrigeration system before opening the service valves. It recommended that a single port refrigeration manifold and hoses rated over 800psi be used. Refrigeration hose valves, along with a vacuum pump and micron gauge, must be used to ensure the system can be vacuumed and held under 500 microns. Check all equipment and hoses for proper usage and leaks before beginning.

### 1. 1st Nitrogen Pressure Test:

Ensure all refrigeration connections are properly flared, secured, and torqued to their respective settings. Pressurize the system with nitrogen to 550psi. Soap all connections with an approved refrigerant leak detection solution. The pressure in the system must hold for one hour respective to the environmental conditions and should not vary less than 540psi. If pressure can not be adequate held, check integrity of flares and torque specifications. Once pressure is held adequately, purge the nitrogen charge to system pressure of 5-10psi. DO NOT RETURN TO ATMOSPHERIC PRESSURE.

### 2. 1st Vacuum Micron Test:

Connect hoses and vacuum pump to the outdoor unit as shown in Fig.28. Start the vacuum pump and vacuum to 1000 microns. Close the valve to the vacuum pump and check for micron rise for 15 minutes. If microns rise to near atmospheric pressure, there is a potential leak; follow Section 8.7.A. If microns rise over 5000, the system is very wet and will require further nitrogen purges.

### 3. 2nd Nitrogen Break:

Once the system holds below 5000 microns, reconnect the nitrogen tank break the system vacuum with 30-50psi of nitrogen. Wait 5 minutes, then purge to 5-10psi. DO NOT RETURN TO ATMOSPHERIC PRESSURE.

### 4. 2nd Vacuum Micron Test:

Reconnect vacuum pump and gauge and begin evacuation. Vacuum system to 500 microns. Close vacuum valve and check for micron rise. Vacuum should hold under 1000 microns. Repeat 8.7.C and 8.7.D until achieved.

### 5. 3rd Nitrogen Break:

Once the system holds below 1000 microns, reconnect the nitrogen tank break the system vacuum with 30-50psi of nitrogen. Wait 5 minutes, then purge to 5-10psi. DO NOT RETURN TO ATMOSPHERIC PRESSURE.

### 6. 3rd Final Vacuum Micron Test:

Reconnect vacuum pump and gauge and begin evacuation. Vacuum system to 300 microns. Close vacuum valve and check for micron rise. Vacuum should hold under 500 microns. Repeat 8.7.C and 8.7.D until achieved. Once held under 500 microns, the system is considered dry and tight.

### 7. Charging the system:

Unscrew Service Valve Caps to expose the inner hexagon head. Use an allen-head spanner or service wrench with appropriate adapter to release the refrigerant into the system. If the calculated line set length is over 24.9ft, weight i n the additional charge with an approved refrigerant scale as needed (Fig.28B).



---

# INSTALLATION

Leak Check, Evacuation, and Charging (Triple Evacuation)

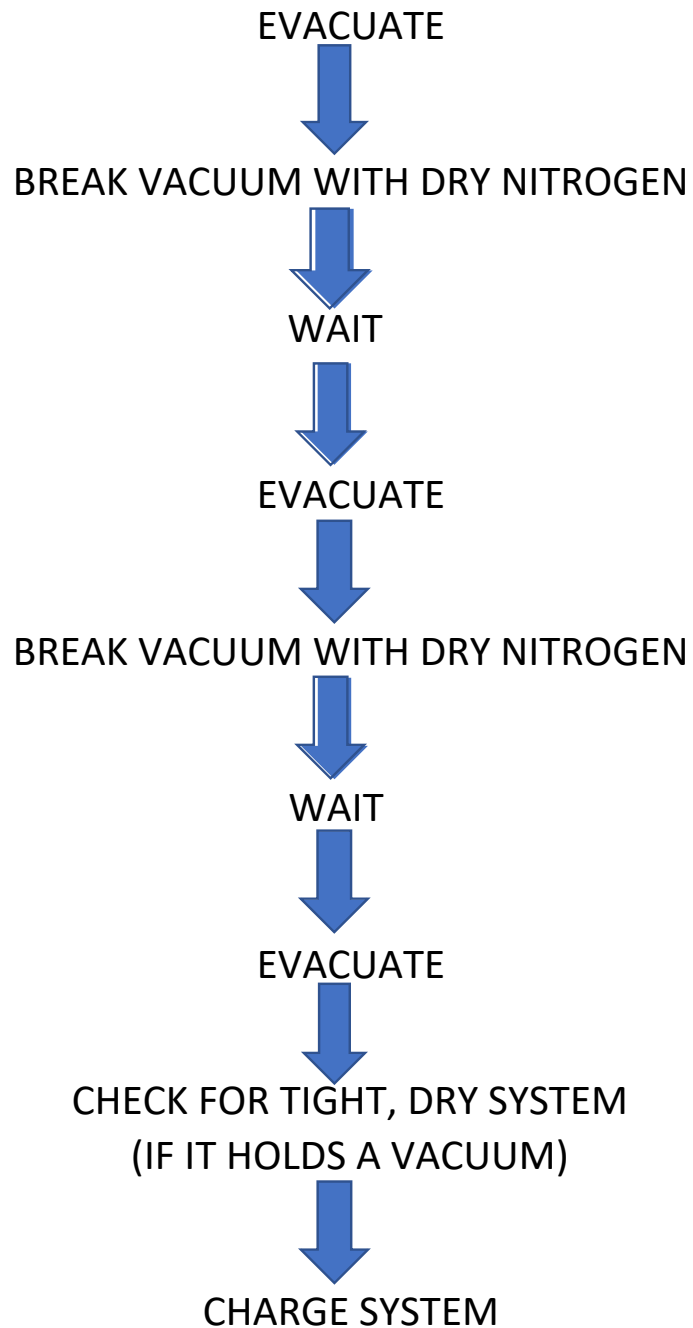

# INSTALLATION

## Checklist and Operation Test

### Check Unit following Installation

| No. | Items to be checked  | Possible malfunction                                  |
|-----|--|---|
| 1   | Has the unit been installed firmly?  | The unit may drop, shake or emit noise.               |
| 2   | Have you done the refrigerant leakage test?                                      | It may cause insufficient cooling (heating) capacity. |
| 3   | Is heat insulation of pipeline sufficient?                                       | It may cause condensation and water dripping.         |
| 4   | Is water drained well?   | It may cause condensation and water dripping.         |
| 5   | Is the voltage of power supply according to the voltage marked on the nameplate? | It may cause malfunction or damage the parts.         |
| 6   | Is electric wiring and pipeline installed correctly?                             | It may cause malfunction or damage the parts.         |
| 7   | Is the unit grounded securely?   | It may cause electric leakage.                        |
| 8   | Does the wiring follow the specifications?                                       | It may cause malfunction or damage the parts.         |
| 9   | Is there any obstruction in air inlet and air outlet?                            | It may cause insufficient cooling (heating).          |
| 10  | Dust and debris not removed after installation?                                  | It may cause malfunction or damaging the parts.       |
| 11  | The gas valve and liquid valve of connection pipe are open completely?           | It may cause insufficient cooling (heating) capacity. |

## Test Operation

### 1. Preparation of Test Operation

The client approves the air conditioner installation.

Specify the important notes for air conditioner to the client.

### 2, Method of test operation

Turn on the power, press ON/OFF button on the remote controller to start operation.

Press MODE button to select AUTO, COOL, DRY, FAN and HEAT to check whether the operation is normal or not.

If the ambient temperature is lower than 60.8°F, the air conditioner can't start cooling.

# REMOVAL

## Indoor Unit

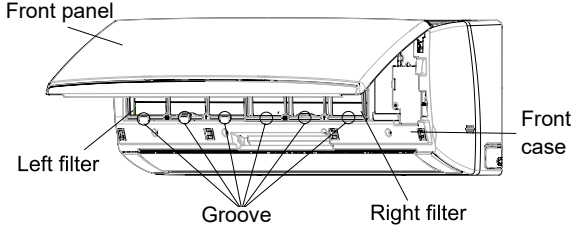
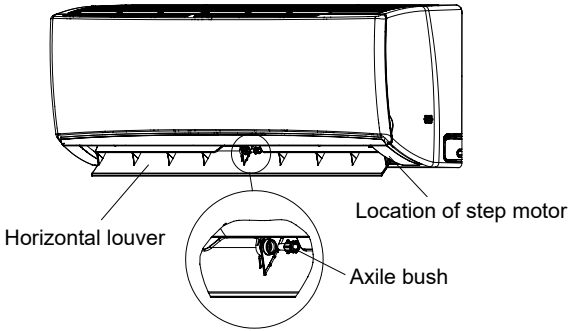
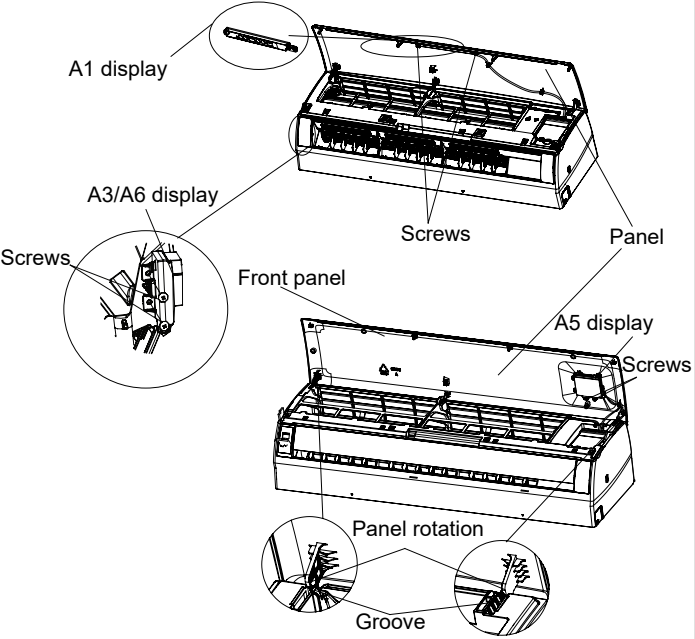
| Step  | Procedure  |
|---|--|
| <p>1. Remove filter assembly</p> <p>Open the front panel. Push the left filter and right filter until they are separate from the groove on the front panel. Remove the left filter and right filter respectively.</p>   |    |
| <p>2. Remove horizontal louver</p> <p>Push out the axle bush on horizontal louver. Bend the horizontal louver with hand and then separate the horizontal louver from the crankshaft of step motor to remove it.</p>   |   |
| <p>3. Remove panel</p> <p>a (1)A1 display: Screw off the 2 screws that are locking the display board. Separate the display board from the front panel.<br/>(2)A3/A5 display: Screw off the 2 screws that are locking the display board.</p> <p>b Separate the panel rotation shaft from the groove fixing the front panel and then removes the front panel.</p> |  |

# REMOVAL

## Indoor Unit

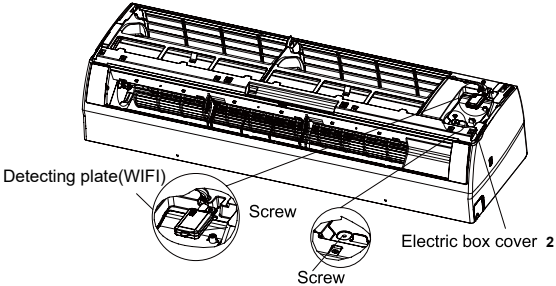
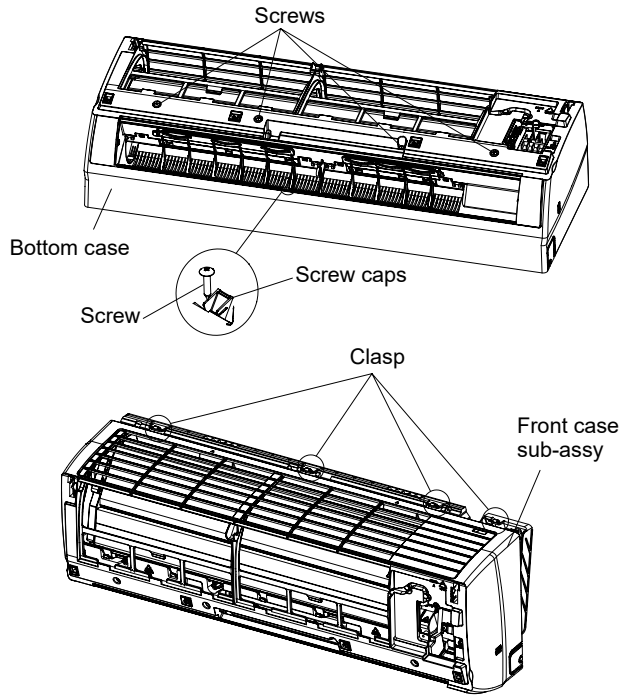
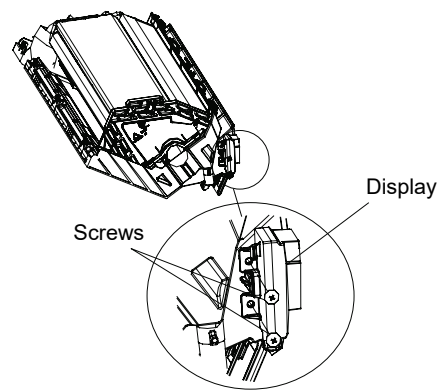
| Step   | Procedure   |
|--|---|
| 4. Remove electric box cover 2 and detecting plate(WIFI) | <p>Remove the screws on the electric box cover 2 and detecting plate(WIFI), then remove the electric box cover 2 and detecting plate(WIFI).</p> <p>Note:the position of detection board(WIFI) may be different for different models.</p>    |
| 5. Remove front case sub-assy                            | <p>a Remove the screws fixing front case.</p> <p>Note:<br/>1.Open the screw caps before removing the screws around the air outlet.<br/>2.The quantity of screws fixing the front case sub-assy is different for different models.</p> <p>b Loosen the connection clasps between front case sub-assy and bottom case. Lift up the front case sub-assy and take it out.</p>  |
| 6. Remove display  | <p>Screw off the 2 screws that are locking the display board.</p>   |

# REMOVAL

## Indoor Unit

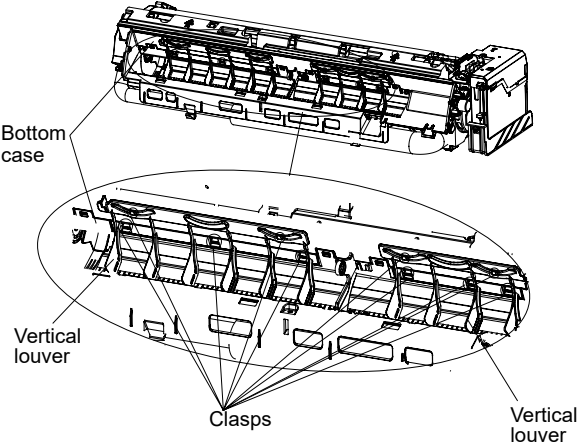
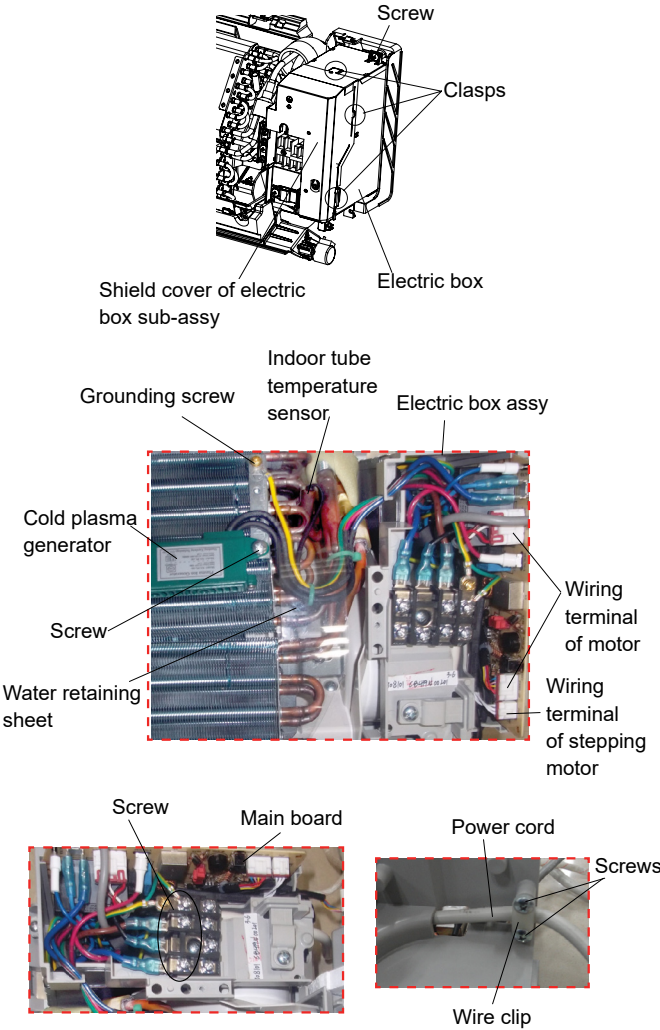
| Steps   | Procedure   |
|---|---|
| <p>7. Remove vertical louver</p> <p>Loosen the connection clasps between vertical louver and bottom case to remove vertical louver.</p>   |  <p>Bottom case</p> <p>Vertical louver</p> <p>Clasps</p> <p>Vertical louver</p>   |
| <p>8. Remove electric box assy</p> <p>a Loosen the connection clasps between shield cover of electric box sub-assy and electric box, and then remove the shield cover of electric box sub-assy. Remove the screw fixing electric box assy .</p> <p>b</p> <ol style="list-style-type: none"> <li>① Take off the water retaining sheet.</li> <li>Remove the cold plasma generator by screwing off the locking screw on the generator.</li> <li>② Take off the indoor tube temperature sensor.</li> <li>③ Screw off 1 grounding screw.</li> <li>④ Remove the wiring terminals of motor and stepping motor.</li> <li>⑤ Remove the electric box assy.</li> </ol> <p>c Twist off the screws that are locking each lead wire and rotate the electric box assy. Twist off the screws that are locking the wire clip. Loosen the power cord and remove it's wiring terminal. Lift up the main board and take it off.</p> |  <p>Screw</p> <p>Clasps</p> <p>Shield cover of electric box sub-assy</p> <p>Electric box</p> <p>Grounding screw</p> <p>Indoor tube temperature sensor</p> <p>Electric box assy</p> <p>Cold plasma generator</p> <p>Water retaining sheet</p> <p>Screw</p> <p>Wiring terminal of motor</p> <p>Wiring terminal of stepping motor</p> <p>Screw</p> <p>Main board</p> <p>Power cord</p> <p>Wire clip</p> <p>Screws</p> |

# REMOVAL

## Indoor Unit

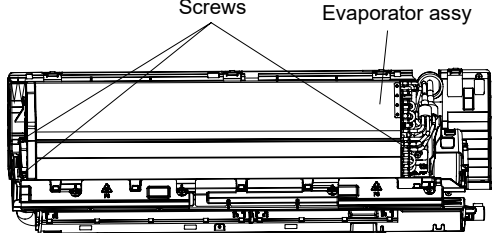
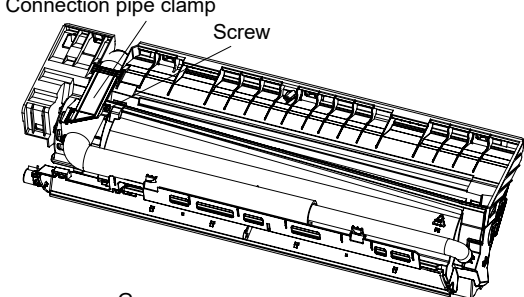
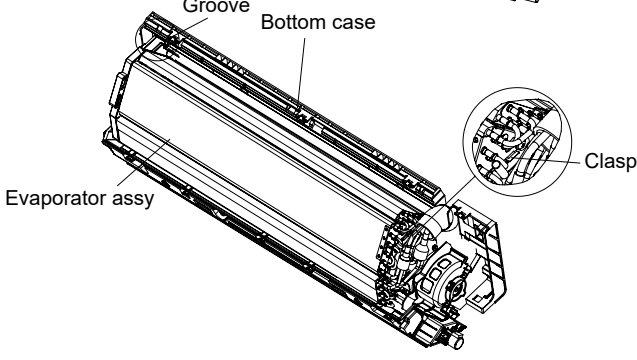
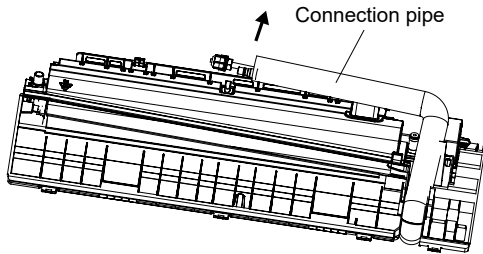
| Steps                     | Procedure   |  |
|---------------------------|---|--|
|                           | <p>Instruction: Some wiring terminal of this product is with lock catch and other devices. The pulling method is as below:</p> <p>① Remove the soft sheath for some terminals at first, hold the circlip and then pull out the terminals.</p> <p>② Pull out the holder for some terminals at first (holder is not available for some wiring terminal), hold the connector and then pull the terminal.</p> |    |
| 9. Remove evaporator assy |   |  |
| a                         | Remove 3 screws fixing evaporator assy.   |    |
| b                         | At the back of the unit, remove the screw fixing connection pipe clamp and then remove the connection pipe clamp.   |  |
| c                         | First remove the left side of the evaporator from the groove of bottom case and then remove the right side from the clasp on the bottom case.   |  |
| d                         | Adjust the position of connection pipe on evaporator slightly and then lift the evaporator upwards to remove it.  |  |

# REMOVAL

## Indoor Unit

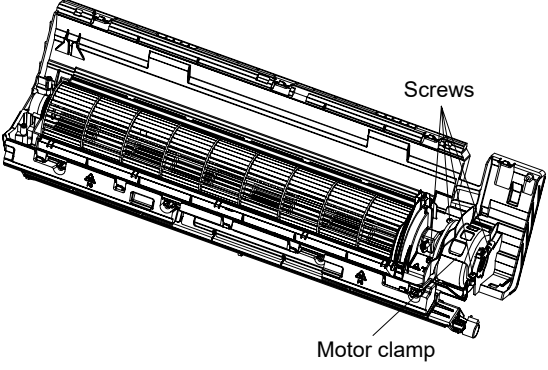
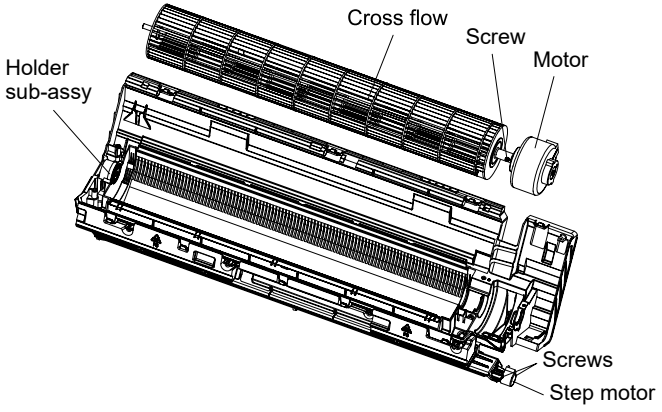
| Steps                                 | Procedure  |
|---------------------------------------|--|
| 10. Remove motor and cross flow blade |  |
| a                                     | <p>Remove the screws fixing motor clamp and then remove the motor clamp.</p>   |
| b                                     | <p>Remove the screws at the connection place of cross flow blade and motor; lift the motor and cross flow blade upwards to remove them.<br/>Remove the bearing holder sub-assy.<br/>Remove the screw fixing step motor and then remove the step motor.</p>  |

# REMOVAL

## Outdoor Unit

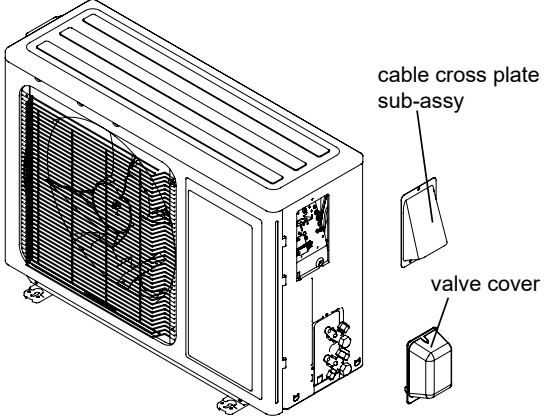
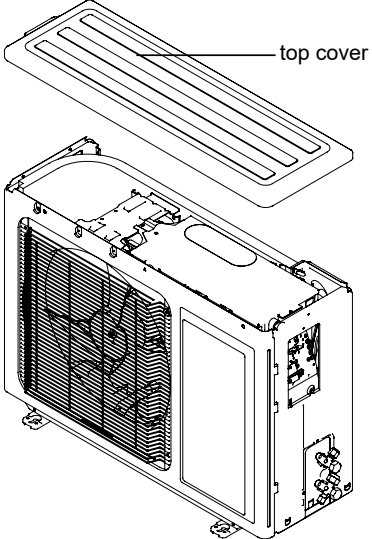
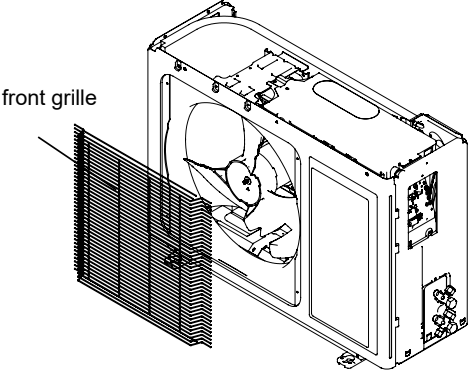
| Steps  | Procedure  |
|--|--|
| <b>1.Remove cable cross plate sub-assy and valve cover</b> |  <p>Remove the screws fixing cable cross plate sub-assy and then remove the cable cross plate sub-assy.</p> <p>Remove the screws fixing valve cover and then remove the valve cover.</p> |
| <b>2.Remove top cover</b>                                  |  <p>Remove connection screws connecting the top cover plate with the front panel and the right side plate, and then remove the top cover.</p>   |
| <b>3.Remove front grille</b>                               |  <p>Remove connection screws between the front grille and the front panel. Then remove the front grille.</p>   |



# REMOVAL

## Outdoor Unit

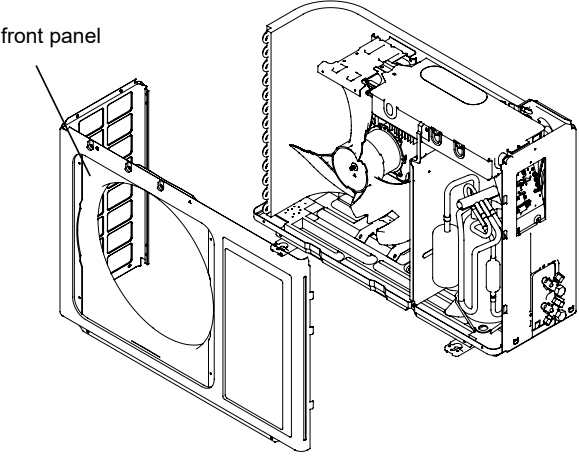
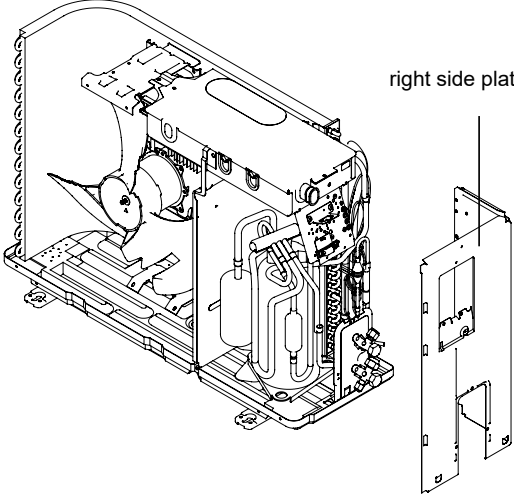
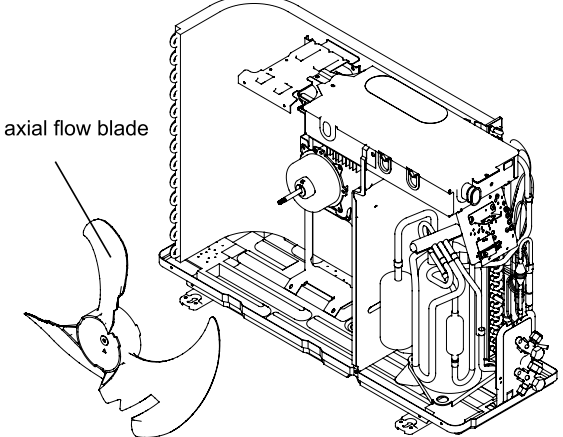
| Steps                            | Procedure   |
|----------------------------------|---|
| <b>4.Remove front panel</b>      | <p data-bbox="300 436 722 527">Remove connection screws connecting the front panel with the chassis and the motor support, and then remove the front panel.</p>               |
| <b>5.Remove right side plate</b> | <p data-bbox="300 982 722 1100">Remove connection screws connecting the right side plate with the valve support and the electric box. Then remove the right side plate.</p>  |
| <b>6.Remove axial flow blade</b> | <p data-bbox="300 1577 722 1633">Remove the nut fixing the blade and then remove the axial flow blade.</p>    |

# REMOVAL

## Outdoor Unit

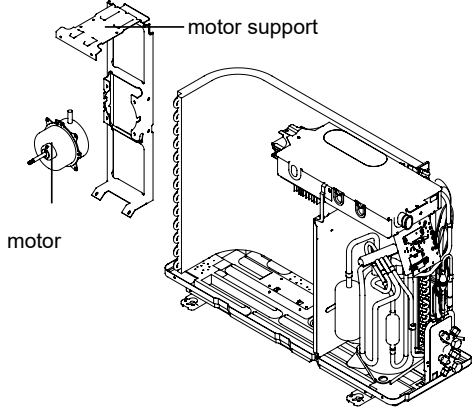
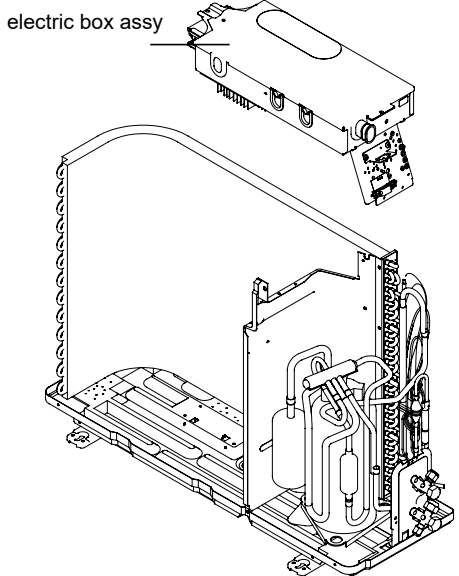
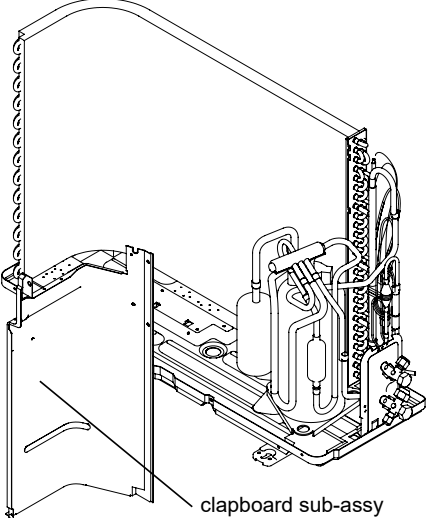
| Steps  | Procedure  |
|--|--|
| <p><b>7.Remove motor and motor support</b></p> <p>Remove the 4 tapping screws fixing the motor. Pull out the lead-out wire and remove the motor. Remove the 2 tapping screws fixing the motor support. Lift motor support to re-move it.</p> |  <p>motor support</p> <p>motor</p> |
| <p><b>8.Remove electric box assy</b></p> <p>Remove the 2 screws fixing the cover of electric box. Lift to remove the cover. Loosen the wire and disconnect the terminal. Lift to re-move the electric box assy.</p>                          |  <p>electric box assy</p>         |
| <p><b>9.Remove clapboard sub-assy</b></p> <p>Loosen the screws of the clapboard sub-assy. The clapboard sub-assy has a hook on the lower side. Lift and pull the clapboard sub-assy to remove.</p>   |  <p>clapboard sub-assy</p>       |

# REMOVAL

## Outdoor Unit

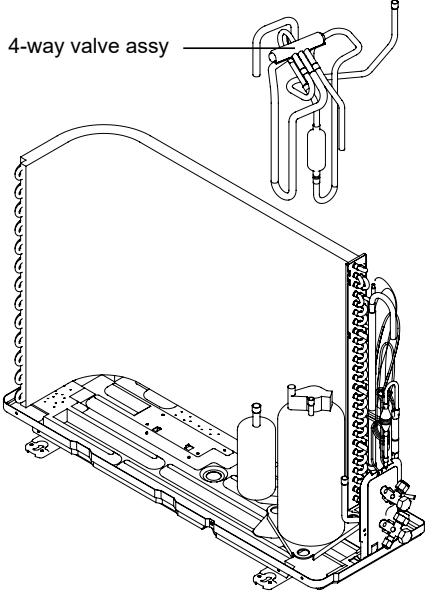
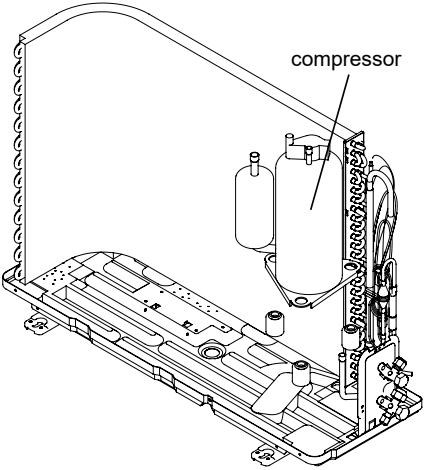
| Steps   | Procedure   |
|---|---|
| <p data-bbox="245 373 565 401"><b>10. Remove 4-way valve assy</b></p> <p data-bbox="310 436 737 758">Unscrew the fastening nut of the 4-way Valve Assy coil and remove the coil. Wrap the 4-way Valve Assy with wet cotton and unsolder the 4 weldspots connecting the 4-way Valve Assy to take it out (Note: Refrigerant should be discharged firstly.) Welding process should be as quickly as possible and keep wrapping cotton wet all the time. Be sure not to burn out the lead-out wire of compressor.</p> | <p data-bbox="948 428 1110 455">4-way valve assy</p>  |
| <p data-bbox="245 1045 509 1073"><b>11. Remove compressor</b></p> <p data-bbox="310 1115 732 1178">Remove the 3 footing screws of the compressor and remove the compressor.</p>   | <p data-bbox="1203 1100 1312 1127">compressor</p>   |

---

# WIRED CONTROLLER

Display

























# WIRED CONTROLLER

Display

WIRED CONTROLLER POWER OWNER'S MANUAL

## 1.2 Instructions for Related Displayed Symbols

| No. | Symbols   | Instructions   |
|-----|---|--|
| 1   |    | Up and down swing function   |
| 2   |    | Left and right swing function  |
| 3   |    | Fresh air function   |
| 4   |    | Sleep function   |
| 5   |    | Auto mode  |
| 6   |    | Cooling mode   |
| 7   |    | Dry mode   |
| 8   |   | Fan mode   |
| 9   |  | Heating mode   |
| 10  |  | Health function  |
| 11  |  | I-Demand function  |
| 12  |  | Absence function   |
| 13  |  | Shielding status (Buttons, temperature, ON/OFF, mode or energy saving is shielded by remote monitor) |
| 14  |  | Current set fan speed  |
| 15  |  | Memory function (Memory in power failure)  |
| 16  |  | DRED function  |
| 17  |  | Save function  |
| 18  |  | X-fan function   |
| 19  |  | Timer on status  |
| 20  |  | Gate card pulled-off status or nobody presented status   |
| 21  |  | Quiet function   |
| 22  |  | Function lock  |

# WIRED CONTROLLER

## Buttons

### 2.1 Button Graphics

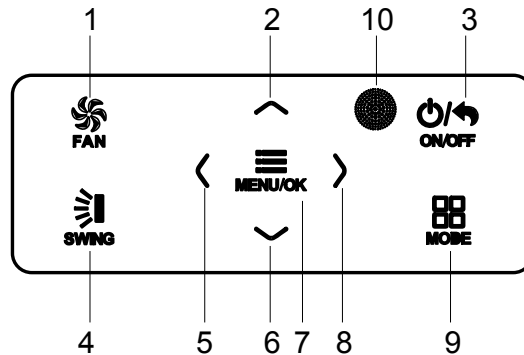

Fig. 2 Button graphics

### 2.2 Function Instructions of Buttons

| No. | Button name                    | Button Function  |
|-----|--------------------------------|--|
| 1   | FAN                            | Set low speed, medium speed, high speed, turbo and auto speed. |
| 2   | ^                              | (1) Set temperature  |
| 6   | ∨                              | (2) Set parameter  |
|     |                                | (3) Move option cursor   |
| 3   | ON/OFF/BACK                    | (1) Turn on or turn off unit<br>(2) Return to last page        |
| 4   | SWING                          | Set up&down swing and set left&right swing                     |
| 5   | <                              | (1) Set related function on or off                             |
| 8   | >                              | (2) Move option cursor   |
|     |                                | (3) Set parameter  |
| 7   | MENU/OK                        | (1) Enter menu page<br>(2) Confirm setting                     |
| 9   | MODE                           | Set auto, cooling, dry, fan and heating modes for indoor unit. |
| 10  | Remote control receiver window |  |

## 3 Operation Instructions

### 3.1 Menu Structure

Normal setting of wired controller can be set directly on the main page, including fan speed, swing, set temperature, mode, ON/OFF. The setting and status view of other functions can be set in corresponding submenu. Detailed menu structure is as shown in Fig. 3.

# WIRED CONTROLLER

## Operation Instructions

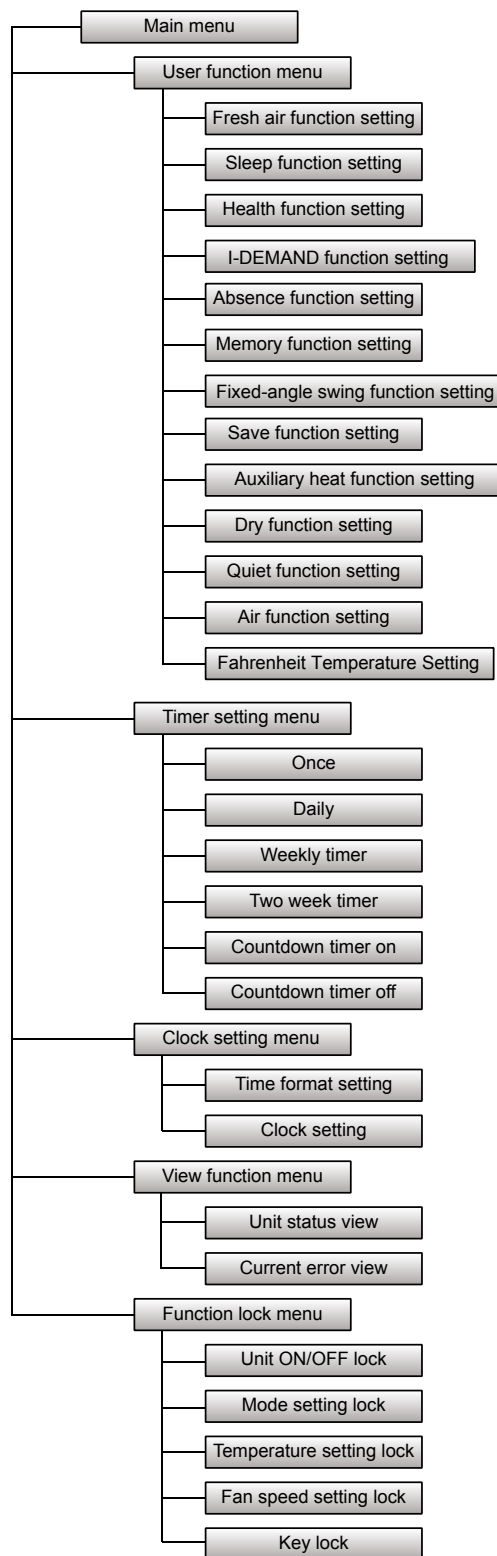

Fig. 3 Menu structure

# WIRED CONTROLLER

## Operation Instructions

### 3.2 On/Off

When the wired control is on main page, press ON/OFF button to turn on the unit. Press ON/OFF button again to turn off the unit. The interfaces of On/Off status are shown in Fig. 4 and Fig. 5.

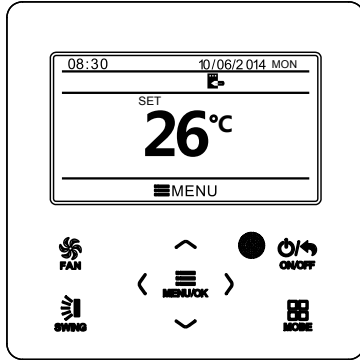

Fig. 4 Off interface

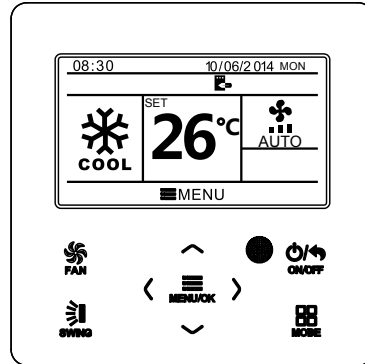
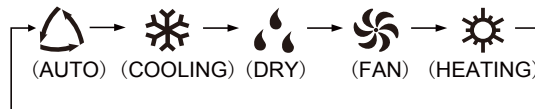

Fig. 5 On interface

### 3.3 Mode Setting

Under On status, pressing MODE button can set mode circularly as:



**Note:** If save function is on, auto mode is not available.

### 3.4 Temperature Setting

Under unit on status, pressing “^” or “v” button on the main page increases or decreases set temperature by 1°C(1°F); holding “^” or “v” button increases or decreases set temperature by 1°C(1°F) every 0.3s.

In cooling, dry, fan and heating mode, temperature setting range is 16°C~30°C (61°F~86°F). Under auto mode, set temperature cannot be adjusted.

### 3.5 Fan Setting

Under On status, pressing FAN button can set fan speed circularly as:

Low→Medium→High→Turbo→Auto→Low

Symbols displayed are as shown in Fig. 6.

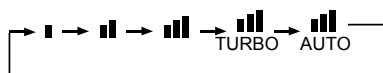

Fig. 6 Fan setting



---

# WIRED CONTROLLER

## Operation Instructions

### 3.6 Swing Setting

In unit on status, press SWING button for swing setting. Two swing modes are available: fixed-angle swing and simple swing.

When fixed-angle swing mode is set, swing operation is as follows:

In unit on status, press SWING button to select up&down swing . Up&down swing angle will be adjusted circularly as below:

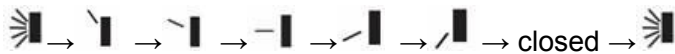



Select up&down swing and left&right swing through “<” or “>” button. When left&right swing  is selected. Left&right swing angle will be adjusted circularly as below:



**Note:**

- ①. Turn on fixed-angle swing mode in function setting page;
- ②. If fixed-angle swing is not available for the model, fixed-angle swing will be invalid when the wired controller turns on fixed-angle swing mode.

Simple swing mode: when fixed-angle swing mode is turned off, swing operation is as below:

Pressing SWING button under unit on status, up&down swing frame occurs. Then press SWING button to turn on or turn off up&down swing.  is displayed when up&down swing is on and is not displayed when up&down swing is off. When up&down swing frame have not disappeared, press “<” or “>” button to switch to left&right swing setting. Then left&right swing frame occurs. In this case, press SWING button to turn on or turn off left&right swing.  is displayed when left&right swing is on and is not displayed when left&right swing is off. For detailed operation, please refer to Fig. 7.

# WIRED CONTROLLER

## Operation Instructions

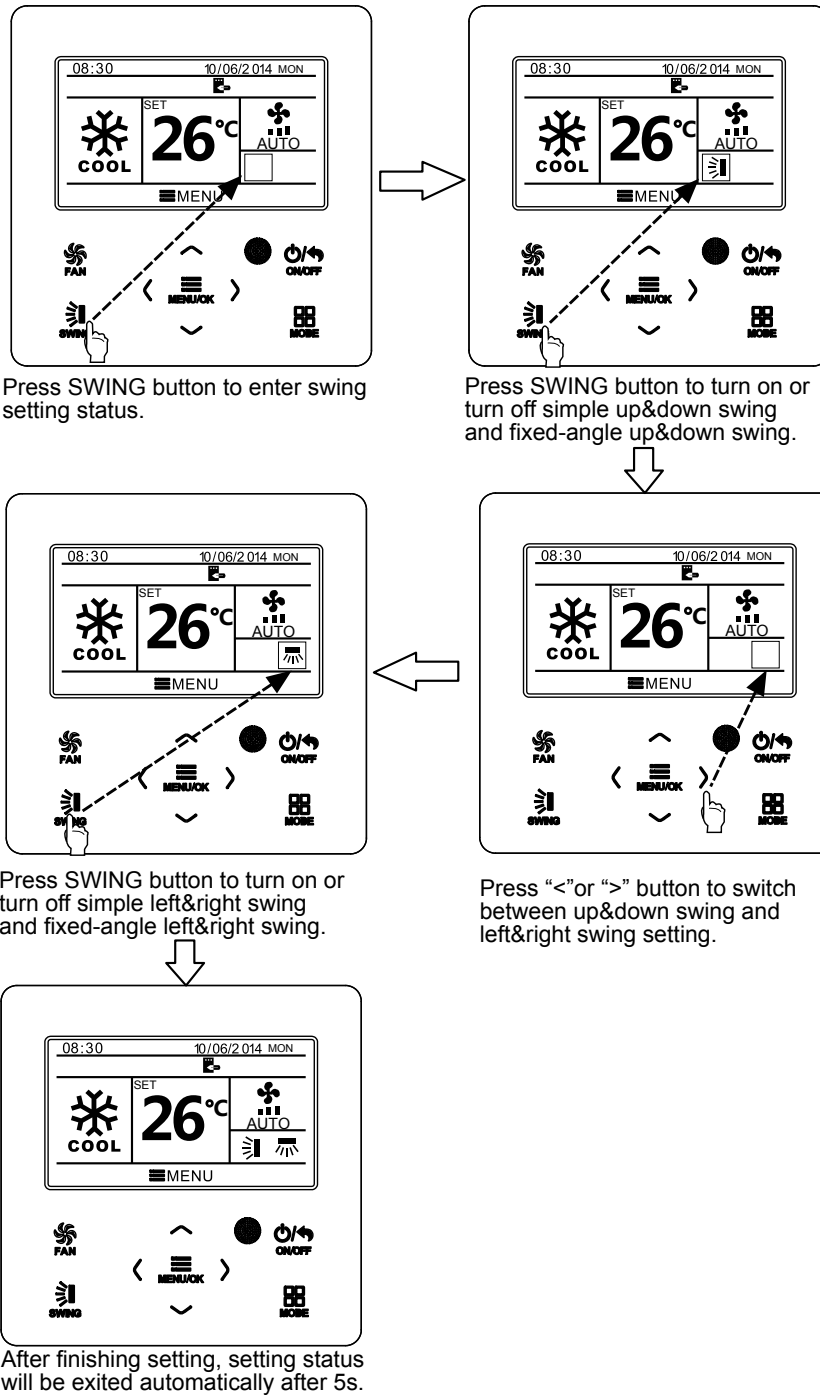

Fig. 7 Swing setting

# WIRED CONTROLLER

## Operation Instructions

### 3.7 Functions Setting

Press MENU/OK button on main page to enter main menu page. Press “^” or “v” or “<” or “>” button to select the function setting symbol. Then press MENU/OK button to enter user function setting page. Press “^” or “v” button to select specific function item. Press “<” or “>” button to turn on or turn off this function. If the function item can't be set, it will displays with gray color. Please refer to Fig.8.

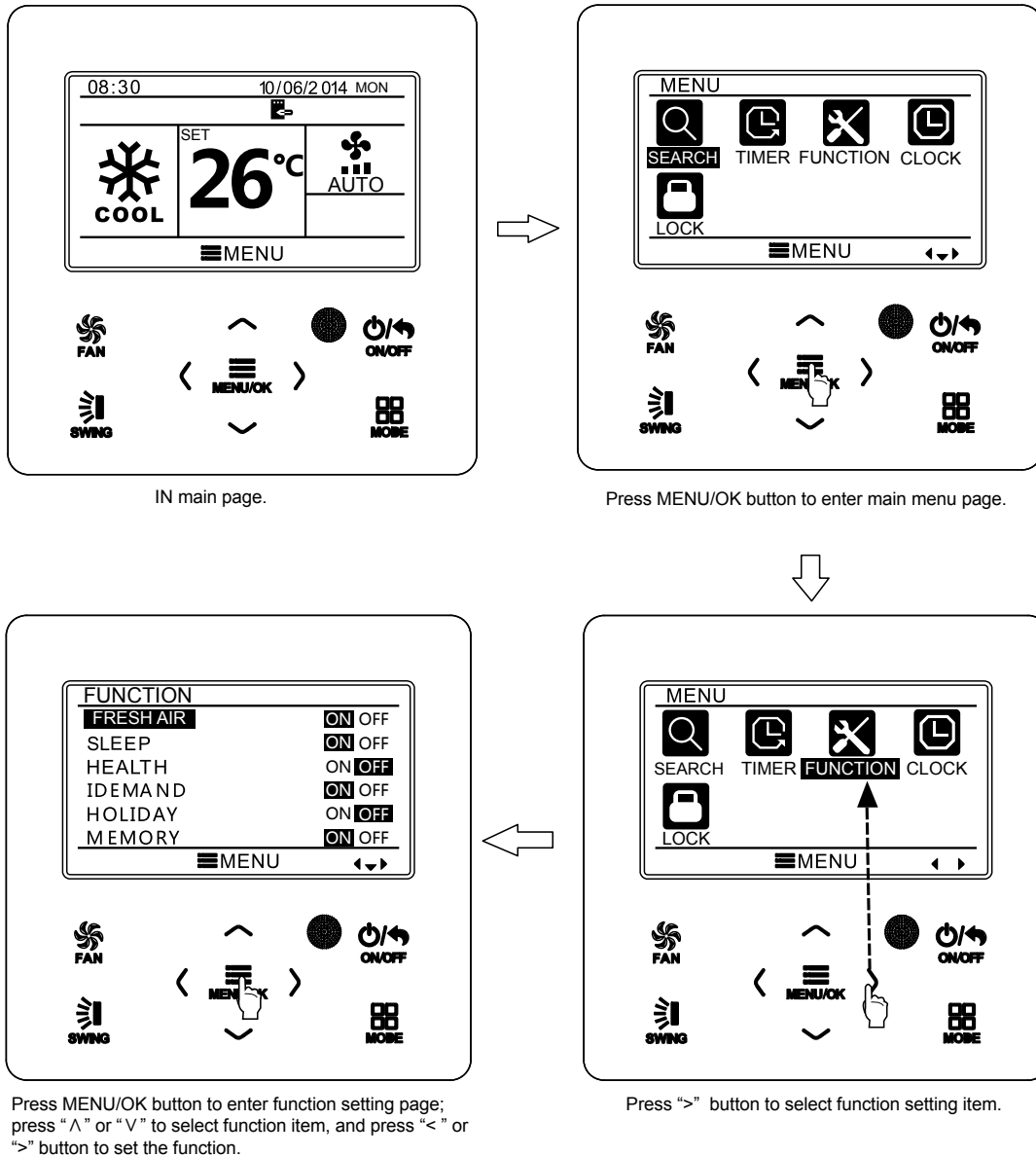

Fig. 8 Function setting

---

# WIRED CONTROLLER

## Operation Instructions

### 3.7.1 Fresh Air Function Setting

After entering user function page, press “^” or “v” button to select fresh air function and press “<” or “>” button to turn on or turn off air function. Press MENU button to adjust the mode of fresh air.

After entering fresh air mode setting, press “^” or “v” button to adjust the mode in the range of 1~10. After setting, press MENU button to save the setting.

### 3.7.2 Sleep Function Setting

After entering user function page, press “^” or “v” button to select sleep function and press “<” or “>” button to turn on or turn off sleep function with auto saving.

If this function is turned on, the unit will operate according to the preset sleep curve to provide comfortable sleep environment.

#### Note:

- In fan or auto mode, sleep function is not available.
- Sleep function will be cancelled when turning off the unit or switching modes.

---

# WIRED CONTROLLER

## Operation Instructions

### 3.7.3 Health Function Setting

After entering user function page, press “^” or “v” button to select health function and press “<” or “>” button to turn on or turn off health function with auto saving.

### 3.7.4 I-DEMAND Function Setting

After entering user function page, press “^” or “v” button to select IDEMAND function option and press “<” or “>” button to turn on or turn off this function with auto saving.

#### Note:

- This function is only available in cooling mode.
- When this function has been set, set temperature is displayed in SE. In this case, temperature setting and fan speed setting are shielded.
- This function will be cancelled when switching modes.
- This function and sleep function cannot be on simultaneously. If I-demand function is set firstly and then sleep function is set, I-demand function will be cancelled while sleep function will be valid, and vice versa.

### 3.7.5 Absence Function Setting

After entering user function page, press “^” or “v” button to select holiday function option and press “<” or “>” button to turn on or turn off this function with auto saving.

This function is used to maintain indoor temperature so that unit can realize fast heating.

#### Note:

- This function is only available in heating mode.
- When this function has been set, set temperature is displayed in 8°C (46°F). In this case, temperature setting and fan speed setting are shielded.
- This function will be cancelled when switching modes.
- This function and sleep function cannot be on simultaneously. If absence function is set firstly and then sleep function is set, absence function will be cancelled while sleep function will be valid, and vice versa.

### 3.7.6 Memory Function Setting

After entering user function page, press “^” or “v” button to select memory function and press “<” or “>” button to turn on or turn off memory function with auto saving.

### 3.7.7 Fixed-angle Swing Mode Setting

After entering user function page, press “^” or “v” button to select lock swing function option and press “<” or “>” button to turn on or turn off this function with auto saving.

**Note:** If fixed-angle swing function is not available for the connected unit, this function will be cancelled automatically after setting.

---

# WIRED CONTROLLER

## Operation Instructions

### 3.7.8 Save Function Setting

After entering user function page, press “^” or “v” button to select save function and press “<” or “>” button to turn on or turn off save function. Press MENU button to enter save function setting page.

After entering save function setting page, press “<” or “>” button to select cooling or heating limitation temperature. After selecting cooling or heating limitation temperature, press “^” or “v” button to adjust limitation temperature value. After setting, press MENU button to save the setting.

**Note:** When save function has been set, auto mode cannot be set.

### 3.7.9 Auxiliary Heating Function Setting

After entering user function page, press “^” or “v” button to select auxiliary heating function and press “<” or “>” button to turn on or turn off this function with auto saving.

### 3.7.10 X-fan Function Setting

After entering user function page, press “^” or “v” button to select dry function option and press “<” or “>” button to turn on or turn off this function with auto saving.

**Note:**

- This function is only available in cooling mode and dry mode.

### 3.7.11 Quiet Function Setting

After entering user function page, press “^” or “v” button to select quiet function and press “<” or “>” button to turn on or turn off this function with auto saving.

**Note:** This function is only available in cooling mode, heating mode and auto mode.

### 3.7.12 Fahrenheit Temperature Setting

After entering user function page, press “^” or “v” button to select Fahrenheit temperature function and press “<” or “>” button to turn on or turn off this function with auto saving. After closing this function, Celsius temperature will be displayed.

# WIRED CONTROLLER

## Operation Instructions

### 3.7.13 Air Function Setting

After entering user function page, press “^” or “v” button to select Air Function and press “<” or “>” button to turn on or turn off air function. Press MENU button to adjust the mode of Air Function .

After entering Air Function mode setting, press “^” or “v” button to adjust the mode in the range of 1~2. After setting, press MENU button to save the setting.

The each mode means as follows:1- suction 2-discharge

### 3.8 Unit Status View

Press MENU button to enter the menu and select the function symbol to be viewed. Then press MENU button to enter view function page. Press “^” or “v” button to select status view function. Press MENU button to enter unit status view page. Press BACK button to return to the last page. Please refer to Fig. 9.

The following statuses can be viewed: if auxiliary heating is operating;indoor ambient temperature; outdoor ambient temperature.

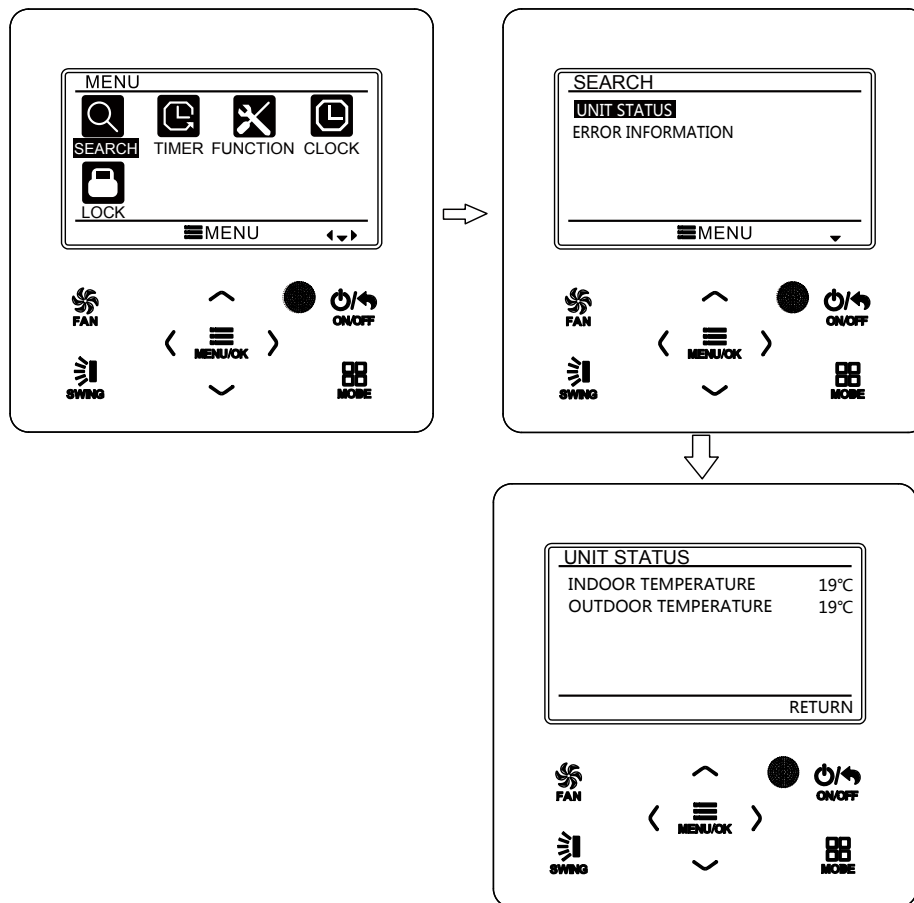

Fig. 9 Status View

# WIRED CONTROLLER

## Operation Instructions

### 3.9 Current Error View

When error occurs in the unit, error symbol will be displayed on the main page of wired controller to indicate that the unit is with error. In this case, you can enter error view page to view the current error.

Press MENU button to enter the menu and select the function symbol to be viewed. Then press MENU button to enter view function page. Press “^” or “v” button to select error information. Press MENU button to enter error view page. If there are too many errors, press “^” or “v” to turn pages. Press BACK button to return to the last page. Please refer to Fig. 10.

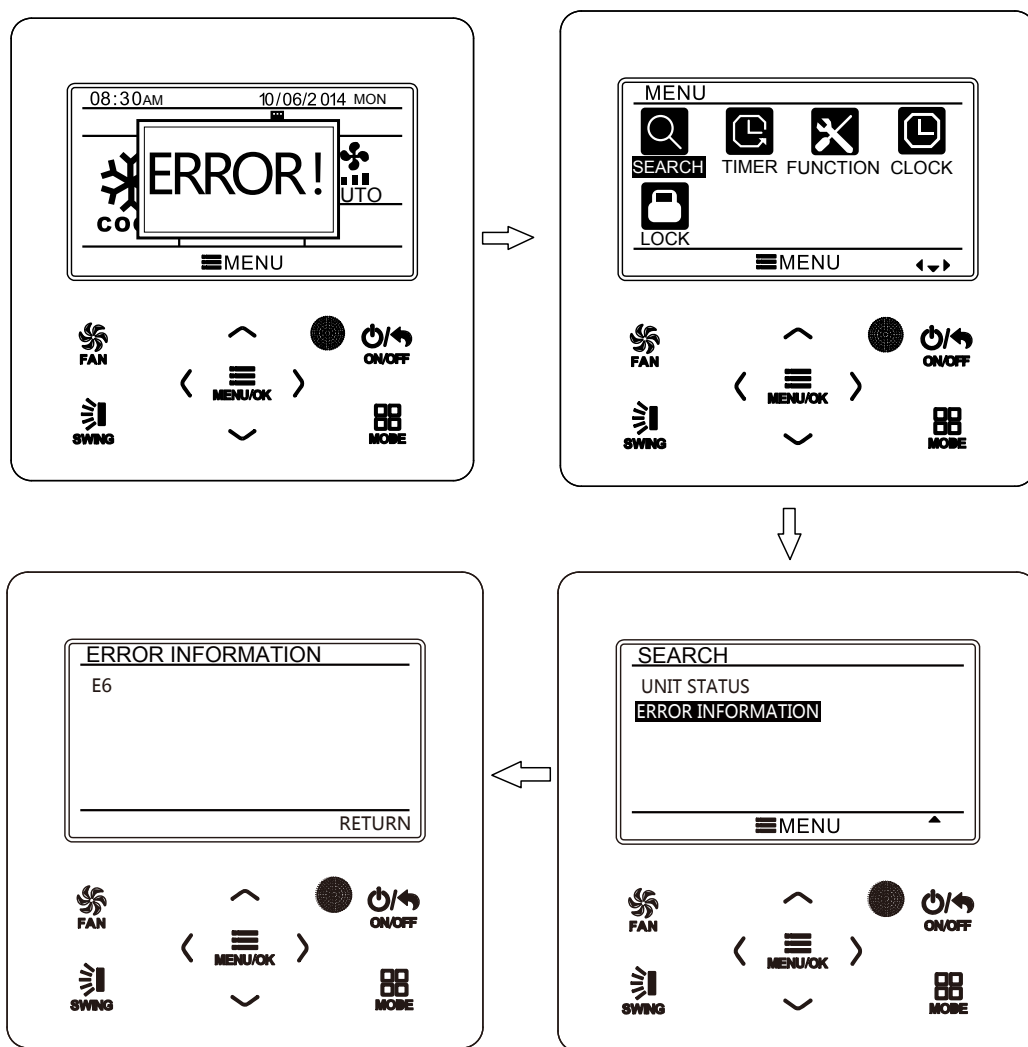

Fig. 10 Current Error View



# WIRED CONTROLLER

## Operation Instructions

| Error   | Error Code | Error   | Error Code |
|---|------------|---|------------|
| Return air temperature sensor open/short circuited                      | F1         | Drive board communication error                                 | P6         |
| evaporator temperature sensor open/short circuited                      | F2         | Compressor overheating protection                               | H3         |
| Indoor unit liquid valve temperature sensor open/short circuited        | b5         | Indoor and outdoor units unmatched                              | LP         |
| Indoor gas valve temperature sensor open/short circuited                | b7         | Communication line misconnected or expansion valve error        | dn         |
| IPM temperature sensor open/short circuited                             | P7         | Running mode conflict   | E7         |
| Outdoor ambient temperature sensor open/short circuited                 | F3         | Pump-down   | Fo         |
| Outdoor unit condenser mid-tube temperature sensor open/short circuited | F4         | Jumper error  | C5         |
| Discharge temperature sensor open/short circuited                       | F5         | Forced defrosting   | H1         |
| Indoor and outdoor communication error                                  | E6         | Compressor startup failure                                      | Lc         |
| DC bus under-voltage protection   | PL         | High discharge temperature protection                           | E4         |
| DC bus over-voltage protection  | PH         | Overload protection   | E8         |
| Compressor phase current sensing circuit error                          | U1         | Whole unit over-current protection                              | E5         |
| Compressor demagnetization protection                                   | HE         | Over phase current protection                                   | P5         |
| PFC protection  | Hc         | Compressor desynchronizing                                      | H7         |
| IPM Temperature Protection  | P8         | IPM Current protection  | H5         |
| Over-power protection   | L9         | Compressor phase loss/reversal protection                       | Ld         |
| System charge shortage or blockage protection                           | F0         | Frequency restricted/reduced with whole unit current protection | F8         |
| Capacitor charging error  | PU         | Frequency restricted/reduced with IPM current protection        | En         |
| High pressure protection  | E1         | Frequency restricted/reduced with high discharge temperature    | F9         |
| Low pressure protection   | E3         | Frequency restricted/reduced with anti-freezing protection      | FH         |
| Compressor stalling   | LE         | Frequency restricted/reduced with overload protection           | F6         |
| Over-speeding   | LF         | Frequency restricted/reduced with IPM temperature protection    | EU         |
| Drive board temperature sensor error                                    | PF         | Indoor unit full water error                                    | E9         |
| AC contactor protection   | P9         | Anti-freezing protection  | E2         |
| Temperature drift protection  | PE         | AC input voltage abnormal                                       | PP         |
| Sensor connection protection  | Pd         | Whole unit current sensing circuit error                        | U5         |
| DC bus voltage drop error   | U3         | 4-way valve reversing error                                     | U7         |
| Outdoor fan 1 error protection  | L3         | Motor stalling  | H6         |
| Outdoor fan 2 error protection  | LA         | PG motor zero-crossing protection                               | U8         |
| compressor inhalation temperature sensor error                          | dc         | Indoor fan tripping error                                       | U0         |

# WIRED CONTROLLER

## Operation Instructions

| Error   | Error Code | Error                          | Error Code |
|---|------------|--------------------------------|------------|
| Communication error between IDU and grid connection | Ln         | IDU network address error      | y3         |
| Communication error between ODU and grid connection | LM         | Ip address allocation overflow | yb         |
| Main error at grid connection side                  | y2         |                                |            |

## 3.10 Timer Setting

The wired controller can set 6 kinds of timer: one time clock timer, everyday timer, one week timer, two week timer, countdown timer on and countdown timer off. Select timer symbol after entering menu page. Press MENU button to enter timer setting page. Press “^” or “v” button to select one kind of timer. Press “<” or “>” button to turn on or turn off this timer. Please refer to Fig. 11.

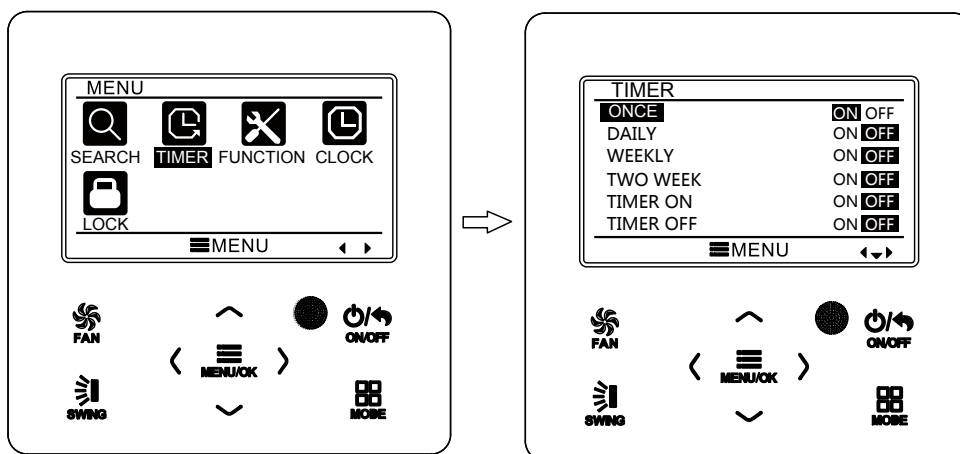

Fig. 11 Turn on or turn off timer

### 3.10.1 One Time Clock Timer

The wired controller can set one time clock timer. If the unit is off, timer on can be set. If the unit is on, timer off can be set. This timer will be carried out for only once when timer time is reached and then the timer will be off automatically.

In timer function setting page, when one time timer is selected, press “<” or “>” button to turn on or turn off this timer function. Press MENU button to enter timer time setting page, as shown in Fig. 12.

Press “<” or “>” button to select timer hour or minute and press “^” or “v” button to adjust time. Holding “^” or “v” button increases or decreases time rapidly. After finishing setting, press MENU button to save timer time.

# WIRED CONTROLLER

## Operation Instructions

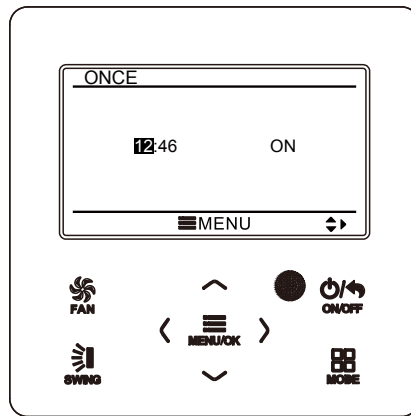

Fig. 12 Setting page of one time clock timer

**Note:** If this timer function is turned on, when the unit is turned on or turned off, this timer function will be cancelled automatically.

### 3.10.2 Daily Timer

In daily timer, user can set eight segments of timer individually. The individual segment will be valid only when it is turned on. In each segment, you can set time, unit ON/OFF, set temperature in cooling (it is valid only when the current mode is cooling), set temperature in heating (it is valid only when the current mode is heating).

Please refer to Fig. 13 to select setting.

After entering daily timer setting page, press “<” or “>” button item. Press “^” or “v” button to adjust the value. Press MENU button to save setting.

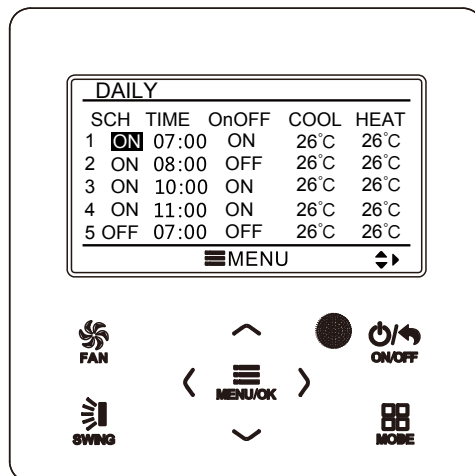

Fig. 13 Daily timer setting

### 3.10.3 Weekly Timer

The user can set the everyday timer content for a week. In each day, the user can set eight segments of timer content. The unit will execute corresponding timer setting in a week.

# WIRED CONTROLLER

## Operation Instructions

After entering weekly timer setting page, press “<” or “>” button to select the day to be set. Then press MENU button to enter timer programming of that day. Press “<” or “>” button to select the item to be set. Press “^” or “v” button to adjust the content. Press MENU button to save setting. Please refer to Fig. 14.

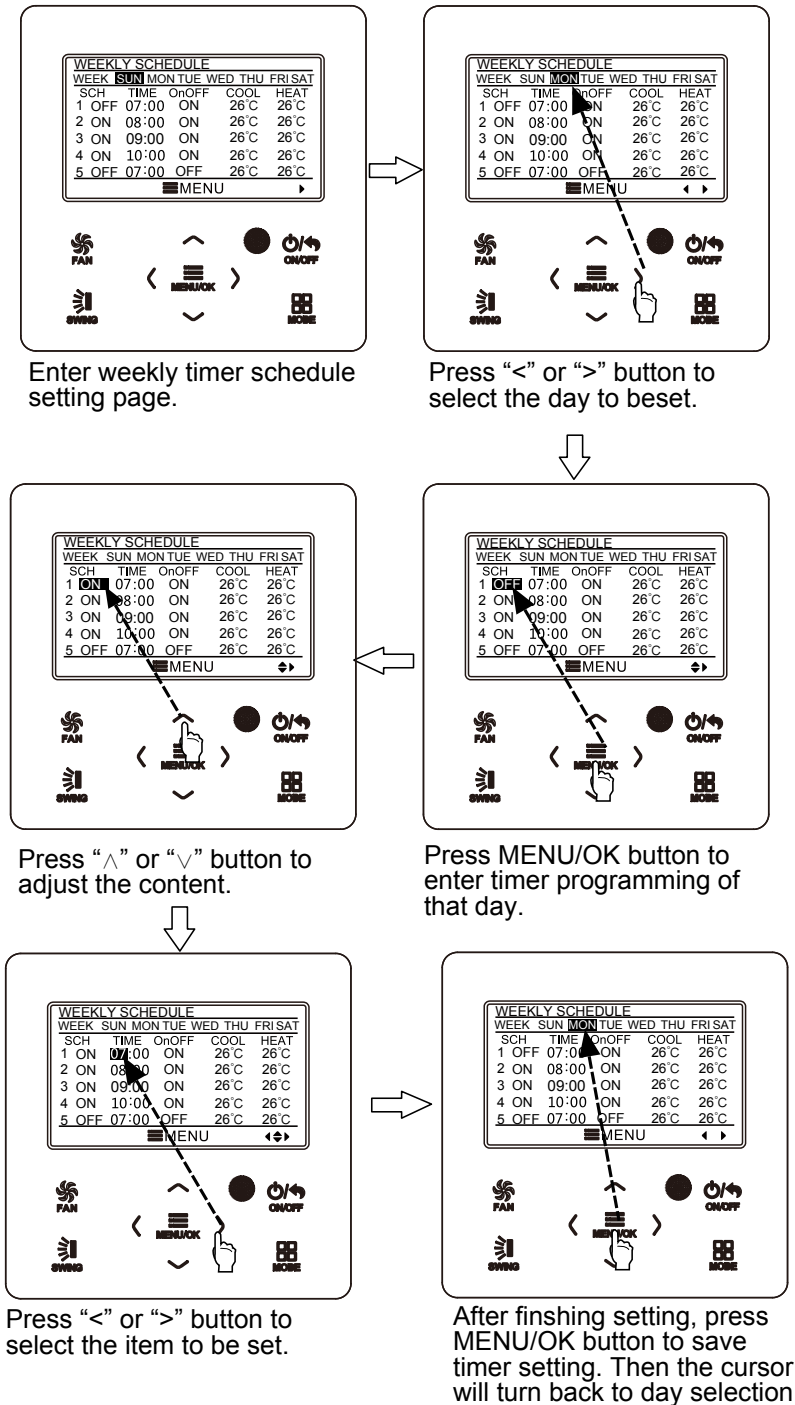

Fig. 14 Weekly timer setting

# WIRED CONTROLLER

## Operation Instructions

### 3.10.4 Two Week Timer

The user can set the everyday timer content for two weeks. In each day, the user can set eight segments of timer content. The unit will execute corresponding timer setting in two weeks.

In timer function setting page, press “^” or “v” button to select two week timer setting and then press MENU button to enter two week timer menu page. Press “^” or “v” button to select current week option and then press “<” or “>” button to set current week as first week or second week. Press MENU button to save current week setting. Please refer to Fig. 15.

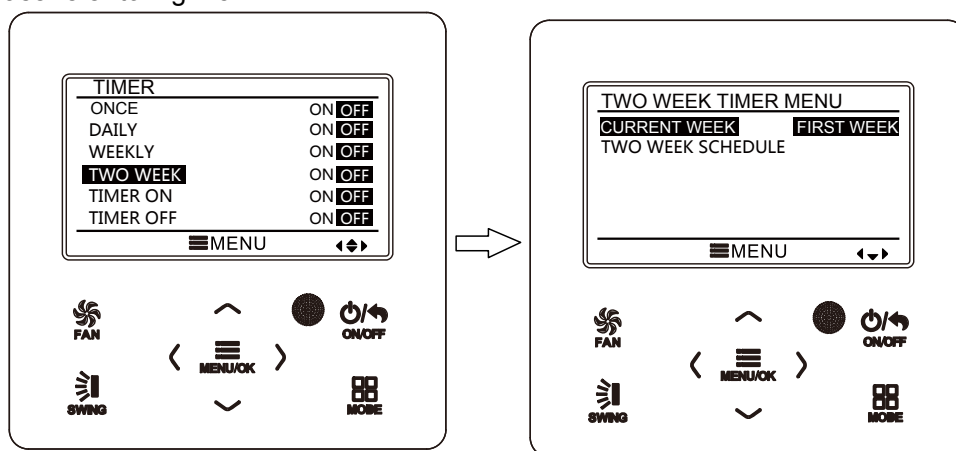

Fig. 15 Setting of current week

After entering two week timer menu page, press “^” or “v” button to select the two week schedule option and then press MENU button to enter two week timer programming. After entering two week timer setting page, press “<” or “>” button to select the day to be set. Then press MENU button to enter timer programming of that day. Press “<” or “>” button to select the item to be set. Press “^” or “v” button to adjust the content. Press MENU button to save setting. Press BACK button to exit this page. The setting symbols please refer to weekly timer setting.

### 3.10.5 Countdown Timer

Countdown timer includes timer on and timer off. Unit On/Off after a desired hour can be set. In unit on status, timer off can be set, or timer off and timer on can be set simultaneously. In unit off status, timer on can be set, or timer off and timer on can be set simultaneously. If timer off in x hours and timer on in y hours are set simultaneously in unit on status, the unit will be off in x hours and then the unit will be on in y hours after timer off.

# WIRED CONTROLLER

## Operation Instructions

After entering timer on setting page, press “^” or “v” button to increases or decreases timer time by 0.5h. Press MENU button to save setting. Press BACK button to return to the last page. Please refer to Fig. 16.

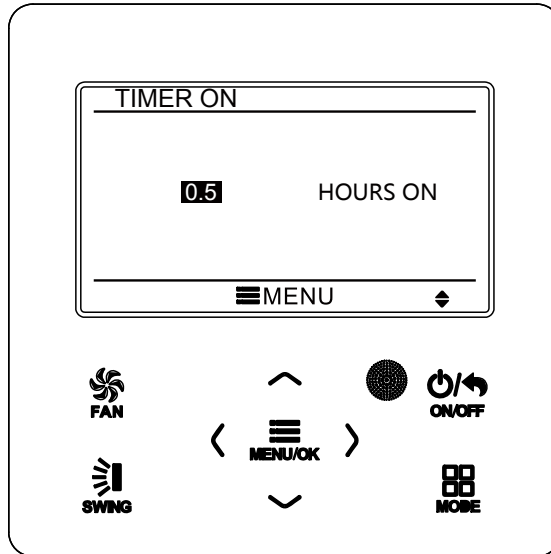

Fig. 16 Countdown timer on

After entering timer off setting page, press “^” or “v” button to increases or decreases timer time by 0.5h. Press MENU button to save setting. Press BACK button to return to the last page. Please refer to Fig. 17.

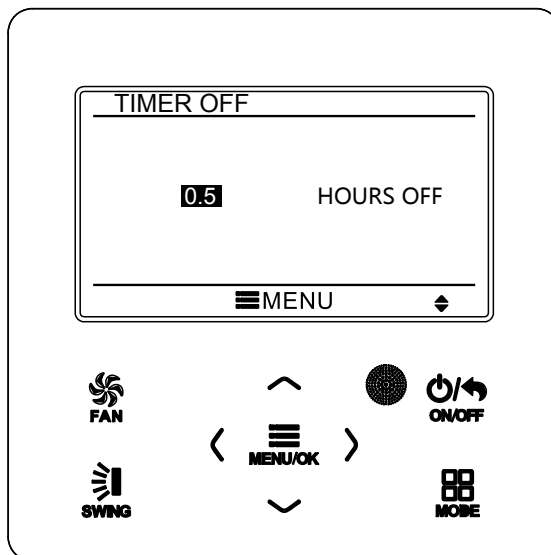

Fig. 17 Countdown timer off

If timer function is on, the set hours will decrease as the unit operation time increases. In this case, residual hours can be viewed after entering timer setting page.

# WIRED CONTROLLER

## Operation Instructions

This timer function will be carried out for only once and then it will be cancelled automatically.

Note: If this timer function is turned on, when the unit is turned on or turned off, this timer function will be cancelled automatically.

### 3.11 Clock Setting

#### 3.11.1 Time Format Setting

The user can set the time format in 12-hour system or 24-hour system. Select clock symbol in menu page and then press MENU button to enter clock setting page. Press “^” or “v” button to select time format and then press “<” or “>” button to select 12-hour system or 24-hour system. Please refer to Fig. 18.

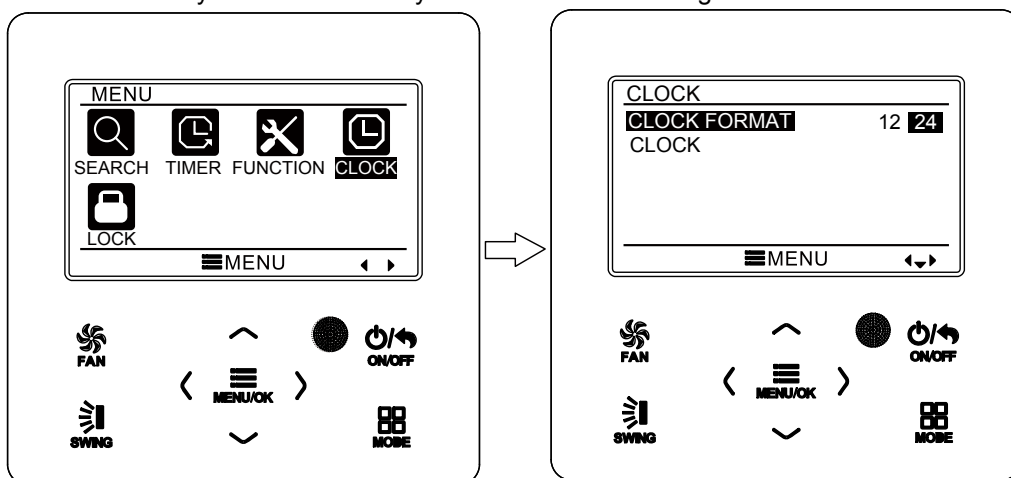

Fig. 18 Time format selection

#### 3.11.2 Clock Setting

Select clock symbol in menu page and then press MENU button to enter clock setting page. Press “^” or “v” button to select time set and then press MENU button to enter time setting.

Press “<” or “>” button to select setting items: hour, minute, year, month, day; press “^” or “v” button to set the value and then press MENU button to save setting. Please refer to Fig. 19.

**Note:** If you need to use both the wired controller and remote controller, please set the time of them identically.

# WIRED CONTROLLER

## Operation Instructions

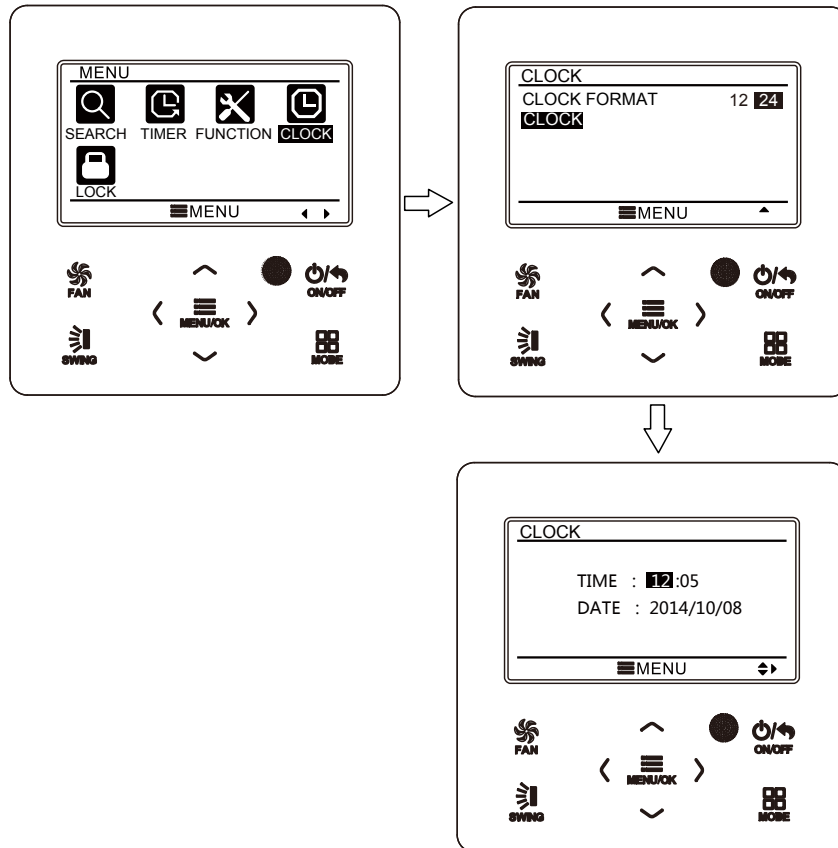

Fig. 19 Clock setting

## 3.12 Lock Setting

Select lock symbol in menu page and then press MENU button to enter lock setting page. Press “^” or “v” button to select the item to be locked and then press “<” or “>” button to lock or unlock. Please refer to Fig. 20.

Items can be locked: ON/OFF, mode setting, temperature setting, fan speed setting, key lock. After locking, the corresponding item cannot be set through buttons.

If the keys are locked, all keys cannot be operated after returning to the main page. Please unlock according to the instructions on main page. During unlocking, press MENU button, press “<” button and then press “>” button to unlock keys.



# WIRED CONTROLLER

## Installation Instructions

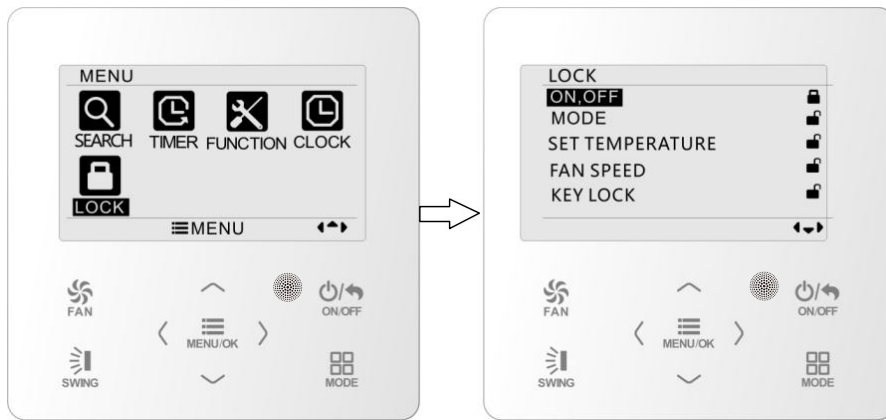

Fig. 20 Lock setting

## 4 Installation Instructions

### 4.1 Parts and Dimension of Wired Controller

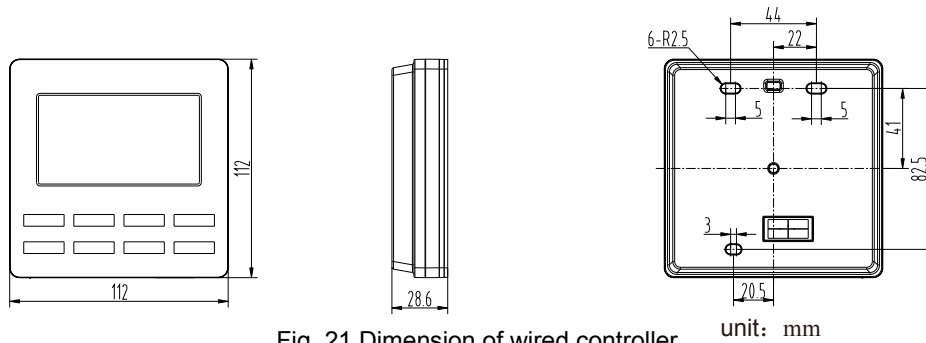

Fig. 21 Dimension of wired controller

unit: mm

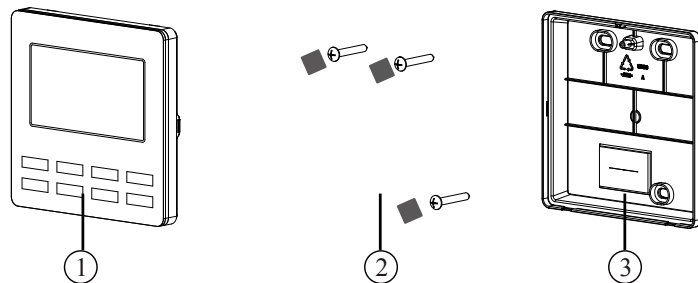

Fig. 22 Parts of wired controller

| No.      | 1                         | 2                             | 3                             |
|----------|---------------------------|-------------------------------|-------------------------------|
| Name     | Panel of wired controller | Sponge 20×20×3<br>Screw M4×25 | Soleplate of wired controller |
| Quantity | 1                         | 3                             | 1                             |

# WIRED CONTROLLER

## Installation Instructions

### 4.2 Installation Requirements

- (1) Prohibit installing the wired controller at wet places.
- (2) Prohibit installing the wired controller at the places with direct sunshine.
- (3) Prohibit installing the wired controller at the place near high temperature objects or water-splashing places.

### 4.3 Installation Methods

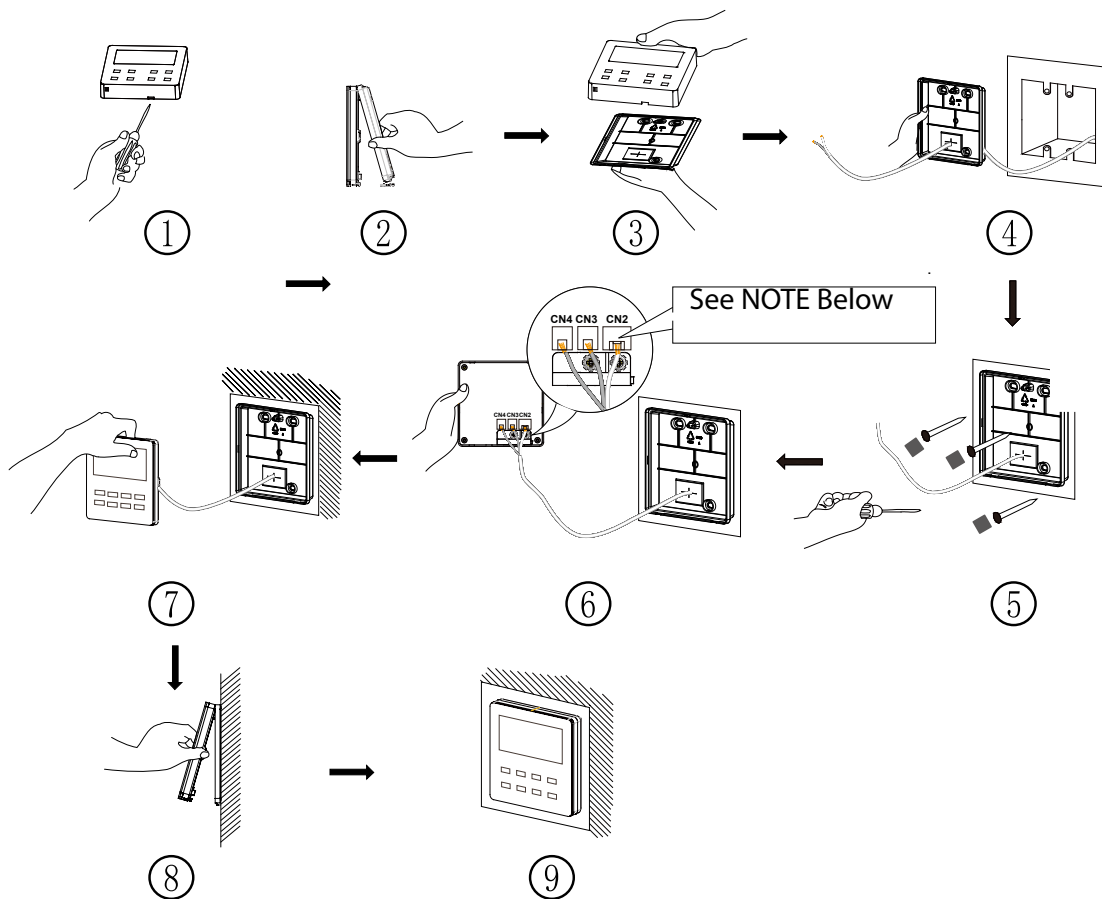

**NOTE:**

CN2 terminal is used for connecting indoor unit and it must be connected. CN3 terminal and CN4 terminal are used for connecting the centralized controller, and these two terminals have the same function. Customers can select one or two terminals for connection according to their requirements.

---

# WIRED CONTROLLER

## Installation Instructions

Fig. 23 Installation diagram for wired controller

Fig. 23 is the simple installation process of wired controller; please pay attention to the following items:

- (1) Before installation, please cut off the power for indoor unit;
- (2) Pull out the four-core twisted pair line from the installation holes and then let it go through the rectangular hole behind the soleplate of the wired controller.
- (3) Stick the soleplate of wired controller on the wall and then use screw M4×25 to fix soleplate and installation hole on wall together, attach the sponge 20×20×3 at the screw hole and then press it with fingers to make sure it's attached firmly.
- (4) Insert the four-core twisted pair line into the slot of the wired controller and then buckle the front panel and the soleplate of the wired controller together.
- (5) Block the four-core wire into the groove at the left side of wiring column; bundle the front panel of wired controller to its soleplate.

### Note:

- Separate the signal and communication lines of the wired controller from the power cord and connection lines between the indoor and outdoor unit, with a minimum interval of 20cm, otherwise the communication of the unit will probably work abnormally.
- If the air conditioning unit is installed where is vulnerable to electromagnetic interference, then the signal and communication lines of the wired controller must be the shielding twisted pair lines.
- The 4-core terminal connects the air conditioner, while the 2-core terminal connects the centralized controller. The connecting method for the 2-core connection wire is same as that of 4-core connection wire.
- No need to set the wire of wired controller into the clasp.

For matching with different models, the patch cord and the connection wire are provided in the packaging box of wired controller. As shown in fig. A.

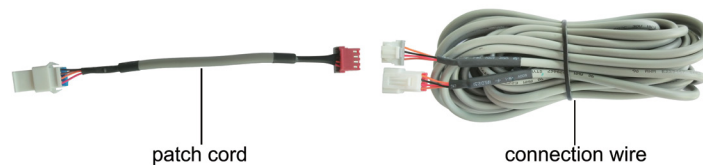

Fig. A: Schematic diagram of patch cord and connection wire

- If the air conditioner has been installed with the patch cord (fig. C) used for connecting the wired controller.

NOTE: If a longer cable is needed, the cable can be cut and spliced utilizing 22x4AWG-THHN wire. This wire should be SHIELDED if running in areas where there will be other wiring or electronics near the cable.

# WIRED CONTROLLER

## Installation Instructions

Only use the connection wire (fig. B) in the packing box of wired controller. Connect the terminal ② to the terminal ④ of patch cord which has been installed on the air conditioner; insert terminal ① to needle stand CN2 of wired controller. If there's protection terminal ③, pull out the protection terminal at first and then install it.



Fig. B: Schematic diagram of connection wire: Connect terminal ① with wired controller CN2; connect terminal ② with the terminal ④ of patch cord

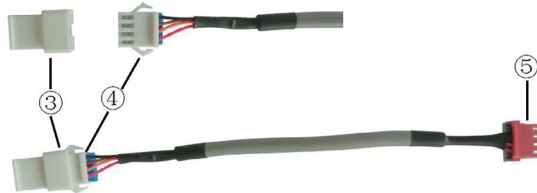

Fig. C: Schematic diagram of patch cord: Terminal ③ is the protection terminal; connect terminal ④ to the terminal ② of connection wire; connect terminal ⑤ to the terminal of wired controller of air conditioner

- If the air conditioner hasn't been installed with the patch cord used for connecting the wired controller.

Use the connection wire and patch cord in the packing box of wired controller. Pull out the protection terminal of patch cord at first, connect the connection wire with the patch cord according to fig. D, and then insert the terminal ① of connection wire into the needle stand CN2 of wired controller and insert the terminal ⑤ of patch cord into the terminal of wired controller of air conditioner as well.

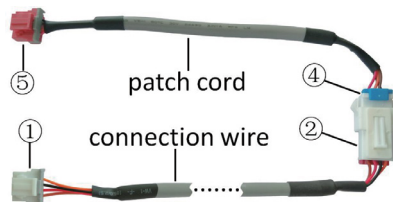

Fig. D: Schematic diagram after the connection wire and the patch cord have been connected: connect the terminal ② of connection wire and the terminal ④ of patch cord

# WIRED CONTROLLER

## Installation Instructions

### 4.4 Disassembly

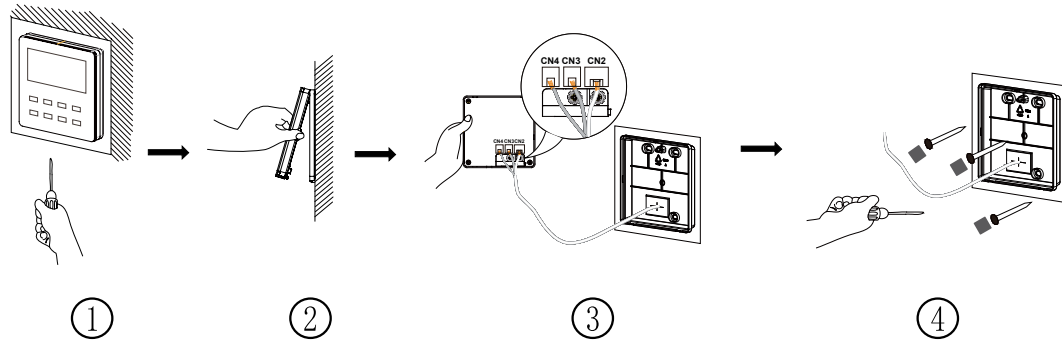

Fig. 24 Disassembly diagram for wired controller

# R-410A SEALED SYSTEM REPAIR

## Service Valves Appearance

|           |                                | 2-way Valve (Liquid Side)  | 3-way Valve (Gas Side)      |                                    |
|-----------|--------------------------------|----------------------------|-----------------------------|------------------------------------|
|           |                                |                            |                             |                                    |
|           |                                | Shaft position             | Shaft position              | Service port                       |
| Shipping  |                                | Closed<br>(with valve cap) | Closed<br>(with valve cap)  | Closed<br>(with cap)               |
| 1.        | Air purging<br>(Installation)  | Closed<br>(clockwise)      | Closed<br>(clockwise)       | Open<br>(with vacuum pump)         |
| Operation |                                | Open<br>(with valve cap)   | Open<br>(with valve cap)    | Closed<br>(with cap)               |
| 2.        | Pumping down<br>(Transferring) | Closed<br>(clockwise)      | Open<br>(counter-clockwise) | Open<br>(connected manifold gauge) |
| 3.        | Evacuation<br>(Servicing)      | Open                       | Open                        | Open<br>(with charging cylinder)   |
| 4.        | Gas charging<br>(Servicing)    | Open                       | Open                        | Open<br>(with charging cylinder)   |
| 5.        | Pressure check<br>(Servicing)  | Open                       | Open                        | Open<br>(with charging cylinder)   |
| 6.        | Gas releasing<br>(Servicing)   | Open                       | Open                        | Open<br>(with charging cylinder)   |

# R-410A SEALED SYSTEM REPAIR

## Pumping Down

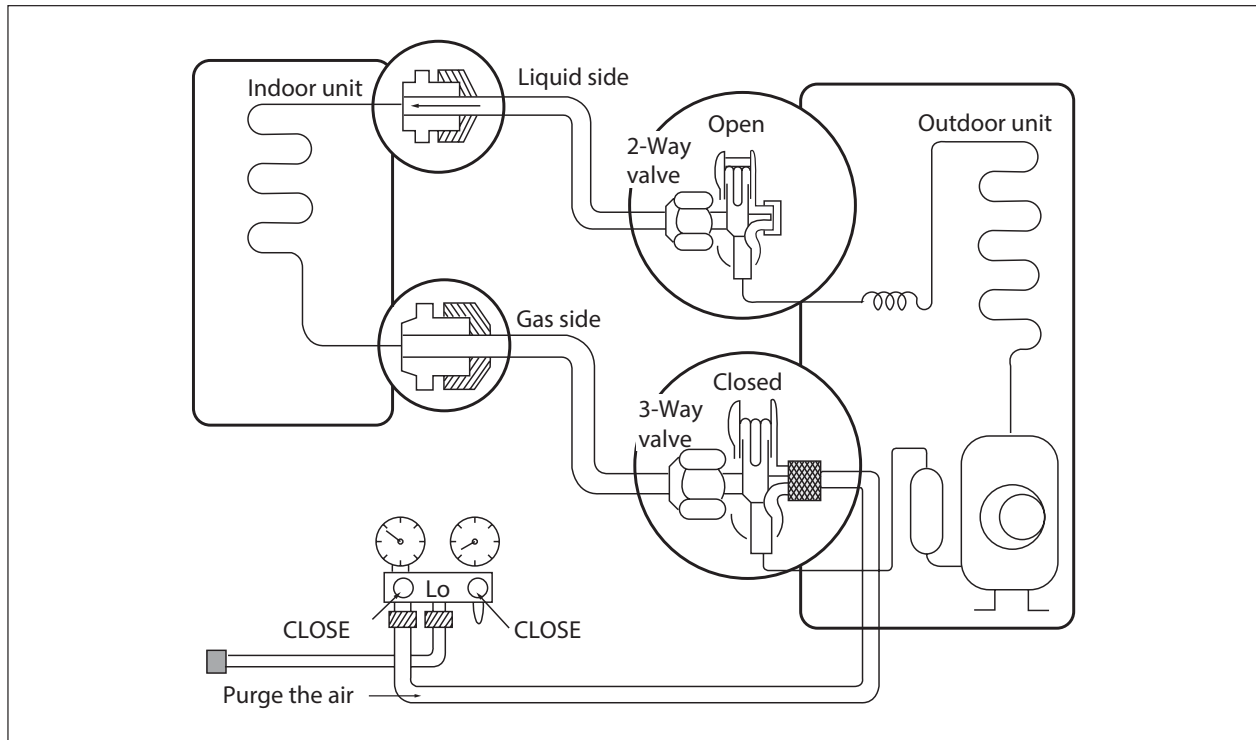

Fig. 505

### • Procedure

**(1) Confirm that both the 2-way and 3-way valves are set to the open position.**

- Remove the valve stem caps and confirm that the valve stems are in the raised position.
- Be sure to use a hexagonal wrench to operate the valve stems.

**(2) Operate the unit for 10 to 15 minutes.**

**(3) Stop operation and wait for 3 minutes, then connect the charge set to the service port of the 3-way valve.**

- Connect the charge hose with the push pin to the service port.

**(4) Air purging of the charge hose.**

- Open the low-pressure valve on the charge set slightly to air purge from the charge hose.

**(5) Set the 2-way valve to the closed position.**

**(6) Operate the air conditioner at the cooling cycle and stop when the gauge indicates 0 psi.**

**(7) Immediately set the 3-way valve to the closed position.**

- Do this quickly so that the gauge ends up indicating 0-15 PSI.

**(8) Disconnect the charge set, and mount the 2-way and 3-way valves stem nuts and the service port nut.**

- Tighten the service port nut.
- Be sure to check for gas leakage.

# R-410A SEALED SYSTEM REPAIR

## Gas Charging (After Repair)

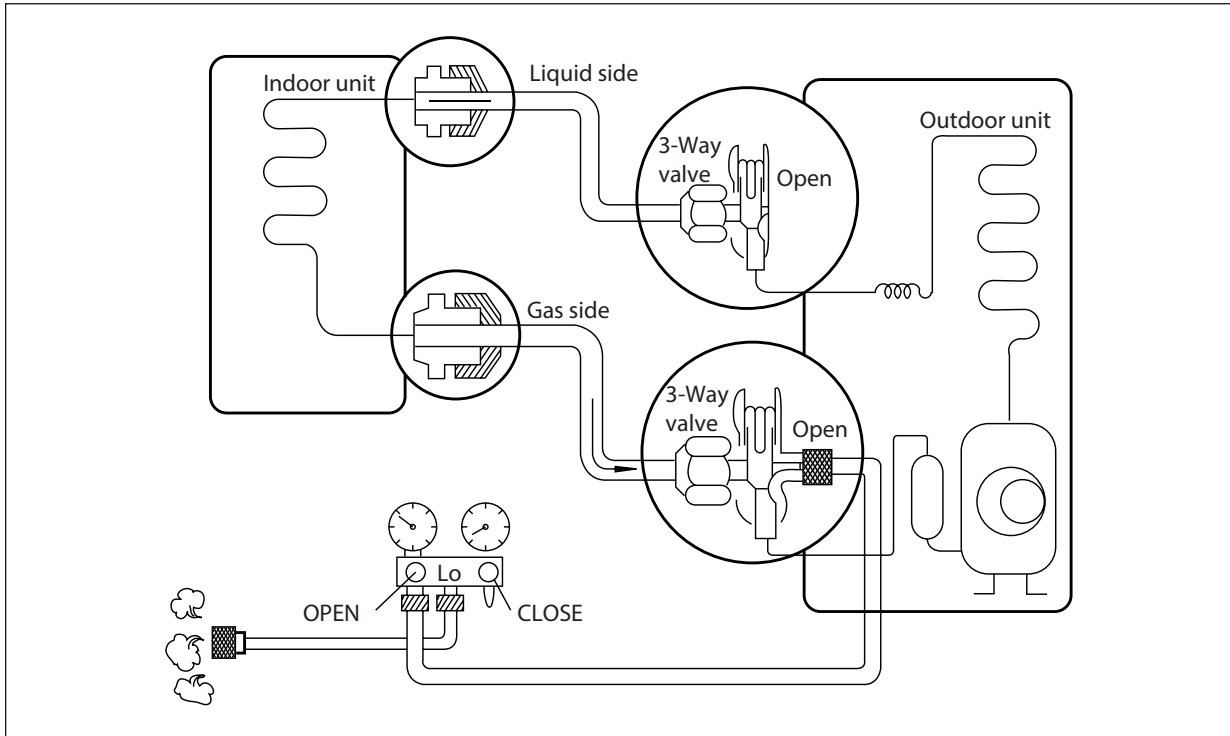

Fig. 506

### • Procedure

#### (1) Connect the charge hose to the charging cylinder.

- Connect the charge hose which you dis-connected from the vacuum pump to the valve at the bottom of the cylinder.
- If you are using a gas cylinder, also use a scale and reverse the cylinder so that the system can be charged with liquid.

#### (2) Purge the air from the charge hose.

- Open the valve at the bottom of the cylinder and press the check valve on the charge set to purge the air. (Be careful of the liquid refrigerant).

#### (3) Open the valve (Lo side on the charge set and charge the system with liquid refrigerant.

- Weigh in the refrigerant amount listed on the rating plate, adding additional refrigerant as needed for long line set length.
- If the temperature does not allow full liquid charge, run the system in air conditioning and throttle refrigerant in at 0.2 oz/min. Allow the system pressure to stabilize each time.

**This is different from previous procedures. Because you are charging with liquid refrigerant from the gas side, absolutely do not attempt to charge with larger amounts of liquid refrigerant while operating the air conditioner.**

#### (4) Immediately disconnect the charge hose from the 3-way valves service port.

- Stopping partway will allow the gas to be discharged.
- If the system has been charged with liquid refrigerant while operating the air conditioner turn off the air conditioner before disconnecting the hose.

#### (5) Mount the valve stem nuts and the service port nut.

- Tighten the service port nut.
- Be sure to check for gas leakage.



# COMPONENTS TESTING

Resistance Table of Ambient Temperature Sensor for Indoor and Outdoor Units (15k $\Omega$ )

| Temp. (°F) | Resistance (k $\Omega$ ) | Temp. (°F) | Resistance (k $\Omega$ ) | Temp. (°F) | Resistance (k $\Omega$ ) | Temp. (°F) | Resistance (k $\Omega$ ) |
|------------|--------------------------|------------|--------------------------|------------|--------------------------|------------|--------------------------|
| -2.2       | 138.1                    | 68         | 18.75                    | 138.2      | 3.848                    | 208.4      | 1.071                    |
| -0.4       | 128.6                    | 69.8       | 17.93                    | 140        | 3.711                    | 210.2      | 1.039                    |
| 1.4        | 121.6                    | 71.6       | 17.14                    | 141.8      | 3.579                    | 212        | 1.009                    |
| 3.2        | 115                      | 73.4       | 16.39                    | 143.6      | 3.454                    | 213.8      | 0.98                     |
| 5          | 108.7                    | 75.2       | 15.68                    | 145.4      | 3.333                    | 215.6      | 0.952                    |
| 6.8        | 102.9                    | 77         | 15                       | 147.2      | 3.217                    | 217.4      | 0.925                    |
| 8.6        | 97.4                     | 78.8       | 14.36                    | 149        | 3.105                    | 219.2      | 0.898                    |
| 10.4       | 92.22                    | 80.6       | 13.74                    | 150.8      | 2.998                    | 221        | 0.873                    |
| 12.2       | 87.35                    | 82.4       | 13.16                    | 152.6      | 2.896                    | 222.8      | 0.848                    |
| 14         | 82.75                    | 84.2       | 12.6                     | 154.4      | 2.797                    | 224 3/5    | 0.825                    |
| 15.8       | 78.43                    | 86         | 12.07                    | 156.2      | 2.702                    | 226.4      | 0.802                    |
| 17.6       | 74.35                    | 87.8       | 11.57                    | 158        | 2.611                    | 228.2      | 0.779                    |
| 19.4       | 70.5                     | 89.6       | 11.09                    | 159.8      | 2.523                    | 230        | 0.758                    |
| 21.2       | 66.88                    | 91.4       | 10.63                    | 161.6      | 2.439                    | 231.8      | 0.737                    |
| 23         | 63.46                    | 93.2       | 10.2                     | 163.4      | 2.358                    | 233.6      | 0.717                    |
| 24.8       | 60.23                    | 95         | 9.779                    | 165.2      | 2.28                     | 235.4      | 0.697                    |
| 26.6       | 57.18                    | 96.8       | 9.382                    | 167        | 2.206                    | 237.2      | 0.678                    |
| 28.4       | 54.31                    | 98.6       | 9.003                    | 168.8      | 2.133                    | 239        | 0.66                     |
| 30.2       | 51.59                    | 100.4      | 8.642                    | 170.6      | 2.064                    | 240.8      | 0.642                    |
| 32         | 49.02                    | 102.2      | 8.297                    | 172.4      | 1.997                    | 242.6      | 0.625                    |
| 33.8       | 46.6                     | 104        | 7.967                    | 174.2      | 1.933                    | 244.4      | 0.608                    |
| 35.6       | 44.31                    | 105.8      | 7.653                    | 176        | 1.871                    | 246.2      | 0.592                    |
| 37.4       | 42.14                    | 107.6      | 7.352                    | 177.8      | 1.811                    | 248        | 0.577                    |
| 39.2       | 40.09                    | 109.4      | 7.065                    | 179.6      | 1.754                    | 249.8      | 0.561                    |
| 41         | 38.15                    | 111.2      | 6.791                    | 181.4      | 1.699                    | 251.6      | 0.547                    |
| 42.8       | 36.32                    | 113        | 6.529                    | 183.2      | 1.645                    | 253.4      | 0.532                    |
| 44.6       | 34.58                    | 114.8      | 6.278                    | 185        | 1.594                    | 255.2      | 0.519                    |
| 46.4       | 32.94                    | 116.6      | 6.038                    | 186.8      | 1.544                    | 257        | 0.505                    |
| 48.2       | 31.38                    | 118.4      | 5.809                    | 188.6      | 1.497                    | 258.8      | 0.492                    |
| 50         | 29.9                     | 120.2      | 5.589                    | 190.4      | 1.451                    | 260.6      | 0.48                     |
| 51.8       | 28.51                    | 122        | 5.379                    | 192.2      | 1.408                    | 262.4      | 0.467                    |
| 53.6       | 27.18                    | 123.8      | 5.197                    | 194        | 1.363                    | 264.2      | 0.456                    |
| 55.4       | 25.92                    | 125.6      | 4.986                    | 195.8      | 1.322                    | 266        | 0.444                    |
| 57.2       | 24.73                    | 127.4      | 4.802                    | 197.6      | 1.282                    | 267.8      | 0.433                    |
| 59         | 23.6                     | 129.2      | 4.625                    | 199.4      | 1.244                    | 269.6      | 0.422                    |
| 60.8       | 22.53                    | 131        | 4.456                    | 201.2      | 1.207                    | 271.4      | 0.412                    |
| 62.6       | 21.51                    | 132 4/5    | 4.294                    | 203        | 1.171                    | 273.2      | 0.401                    |
| 64.4       | 20.54                    | 134.6      | 4.139                    | 204.8      | 1.136                    | 275        | 0.391                    |
| 66.2       | 19.63                    | 136.4      | 3.99                     | 206.6      | 1.103                    | 276.8      | 0.382                    |

# COMPONENTS TESTING

Resistance Table of Ambient Temperature Sensor for Indoor and Outdoor Units (20k $\Omega$ )

| Temp. (°F) | Resistance (k $\Omega$ ) | Temp. (°F) | Resistance (k $\Omega$ ) | Temp. (°F) | Resistance (k $\Omega$ ) | Temp. (°F) | Resistance (k $\Omega$ ) |
|------------|--------------------------|------------|--------------------------|------------|--------------------------|------------|--------------------------|
| -2.2       | 181.4                    | 68         | 25.01                    | 138.2      | 5.13                     | 208.4      | 1.427                    |
| -0.4       | 171.4                    | 69.8       | 23.9                     | 140        | 4.948                    | 210.2      | 1.386                    |
| 1.4        | 162.1                    | 71.6       | 22.85                    | 141.8      | 4.773                    | 212        | 1.346                    |
| 3.2        | 153.3                    | 73.4       | 21.85                    | 143.6      | 4.605                    | 213.8      | 1.307                    |
| 5          | 145                      | 75.2       | 20.9                     | 145.4      | 4.443                    | 215.6      | 1.269                    |
| 6.8        | 137.2                    | 77         | 20                       | 147.2      | 4.289                    | 217.4      | 1.233                    |
| 8.6        | 129.9                    | 78.8       | 19.14                    | 149        | 4.14                     | 219.2      | 1.198                    |
| 10.4       | 123                      | 80.6       | 18.13                    | 150.8      | 3.998                    | 221        | 1.164                    |
| 12.2       | 116.5                    | 82.4       | 17.55                    | 152.6      | 3.861                    | 222.8      | 1.131                    |
| 14         | 110.3                    | 84.2       | 16.8                     | 154.4      | 3.729                    | 224 3/5    | 1.099                    |
| 15.8       | 104.6                    | 86         | 16.1                     | 156.2      | 3.603                    | 226.4      | 1.069                    |
| 17.6       | 99.13                    | 87.8       | 15.43                    | 158        | 3.481                    | 228.2      | 1.039                    |
| 19.4       | 94                       | 89.6       | 14.79                    | 159.8      | 3.364                    | 230        | 1.01                     |
| 21.2       | 89.17                    | 91.4       | 14.18                    | 161.6      | 3.252                    | 231.8      | 0.983                    |
| 23         | 84.61                    | 93.2       | 13.59                    | 163.4      | 3.144                    | 233.6      | 0.956                    |
| 24.8       | 80.31                    | 95         | 13.04                    | 165.2      | 3.04                     | 235.4      | 0.93                     |
| 26.6       | 76.24                    | 96.8       | 12.51                    | 167        | 2.94                     | 237.2      | 0.904                    |
| 28.4       | 72.41                    | 98.6       | 12                       | 168.8      | 2.844                    | 239        | 0.88                     |
| 30.2       | 68.79                    | 100.4      | 11.52                    | 170.6      | 2.752                    | 240.8      | 0.856                    |
| 32         | 65.37                    | 102.2      | 11.06                    | 172.4      | 2.663                    | 242.6      | 0.833                    |
| 33.8       | 62.13                    | 104        | 10.62                    | 174.2      | 2.577                    | 244.4      | 0.811                    |
| 35.6       | 59.08                    | 105.8      | 10.2                     | 176        | 2.495                    | 246.2      | 0.77                     |
| 37.4       | 56.19                    | 107.6      | 9.803                    | 177.8      | 2.415                    | 248        | 0.769                    |
| 39.2       | 53.46                    | 109.4      | 9.42                     | 179.6      | 2.339                    | 249.8      | 0.746                    |
| 41         | 50.87                    | 111.2      | 9.054                    | 181.4      | 2.265                    | 251.6      | 0.729                    |
| 42.8       | 48.42                    | 113        | 8.705                    | 183.2      | 2.194                    | 253.4      | 0.71                     |
| 44.6       | 46.11                    | 114.8      | 8.37                     | 185        | 2.125                    | 255.2      | 0.692                    |
| 46.4       | 43.92                    | 116.6      | 8.051                    | 186.8      | 2.059                    | 257        | 0.674                    |
| 48.2       | 41.84                    | 118.4      | 7.745                    | 188.6      | 1.996                    | 258.8      | 0.658                    |
| 50         | 39.87                    | 120.2      | 7.453                    | 190.4      | 1.934                    | 260.6      | 0.64                     |
| 51.8       | 38.01                    | 122        | 7.173                    | 192.2      | 1.875                    | 262.4      | 0.623                    |
| 53.6       | 36.24                    | 123.8      | 6.905                    | 194        | 1.818                    | 264.2      | 0.607                    |
| 55.4       | 34.57                    | 125.6      | 6.648                    | 195.8      | 1.736                    | 266        | 0.592                    |
| 57.2       | 32.98                    | 127.4      | 6.403                    | 197.6      | 1.71                     | 267.8      | 0.577                    |
| 59         | 31.47                    | 129.2      | 6.167                    | 199.4      | 1.658                    | 269.6      | 0.563                    |
| 60.8       | 30.04                    | 131        | 5.942                    | 201.2      | 1.609                    | 271.4      | 0.549                    |
| 62.6       | 28.68                    | 132 4/5    | 5.726                    | 203        | 1.561                    | 273.2      | 0.535                    |
| 64.4       | 27.39                    | 134.6      | 5.519                    | 204.8      | 1.515                    | 275        | 0.521                    |
| 66.2       | 26.17                    | 136.4      | 5.32                     | 206.6      | 1.47                     | 276.8      | 0.509                    |

# COMPONENTS TESTING

Resistance Table of Ambient Temperature Sensor for Indoor and Outdoor Units (50k $\Omega$ )

| Temp. (°F) | Resistance (k $\Omega$ ) | Temp. (°F) | Resistance (k $\Omega$ ) | Temp. (°F) | Resistance (k $\Omega$ ) | Temp. (°F) | Resistance (k $\Omega$ ) |
|------------|--------------------------|------------|--------------------------|------------|--------------------------|------------|--------------------------|
| -20.2      | 853.5                    | 50         | 98                       | 120.2      | 18.34                    | 190.4      | 4.754                    |
| -18.4      | 799.8                    | 51.8       | 93.42                    | 122        | 17.65                    | 192.2      | 4.609                    |
| -16.6      | 750                      | 53.6       | 89.07                    | 123.8      | 16.99                    | 194        | 4.469                    |
| -14.8      | 703.8                    | 55.4       | 84.95                    | 125.6      | 16.36                    | 195.8      | 4.334                    |
| -13        | 660.8                    | 57.2       | 81.05                    | 127.4      | 15.75                    | 197.6      | 4.204                    |
| -11.2      | 620.8                    | 59         | 77.35                    | 129.2      | 15.17                    | 199.4      | 4.079                    |
| -9.4       | 580.6                    | 60.8       | 73.83                    | 131        | 14.62                    | 201.2      | 3.958                    |
| -7.6       | 548.9                    | 62.6       | 70.5                     | 132 4/5    | 14.09                    | 203        | 3.841                    |
| -5.8       | 516.6                    | 64.4       | 67.34                    | 134.6      | 13.58                    | 204.8      | 3.728                    |
| -4         | 486.5                    | 66.2       | 64.33                    | 136.4      | 13.09                    | 206.6      | 3.619                    |
| -2.2       | 458.3                    | 68         | 61.48                    | 138.2      | 12.62                    | 208.4      | 3.514                    |
| -0.4       | 432                      | 69.8       | 58.77                    | 140        | 12.17                    | 210.2      | 3.413                    |
| 1.4        | 407.4                    | 71.6       | 56.19                    | 141.8      | 11.74                    | 212        | 3.315                    |
| 3.2        | 384.5                    | 73.4       | 53.74                    | 143.6      | 11.32                    | 213.8      | 3.22                     |
| 5          | 362.9                    | 75.2       | 51.41                    | 145.4      | 10.93                    | 215.6      | 3.129                    |
| 6.8        | 342.8                    | 77         | 49.19                    | 147.2      | 10.54                    | 217.4      | 3.04                     |
| 8.6        | 323.9                    | 78.8       | 47.08                    | 149        | 10.18                    | 219.2      | 2.955                    |
| 10.4       | 306.2                    | 80.6       | 45.07                    | 150.8      | 9.827                    | 221        | 2.872                    |
| 12.2       | 289.6                    | 82.4       | 43.16                    | 152.6      | 9.489                    | 222.8      | 2.792                    |
| 14         | 274                      | 84.2       | 41.34                    | 154.4      | 9.165                    | 224 3/5    | 2.715                    |
| 15.8       | 259.3                    | 86         | 39.61                    | 156.2      | 8.854                    | 226.4      | 2.64                     |
| 17.6       | 245.6                    | 87.8       | 37.96                    | 158        | 8.555                    | 228.2      | 2.568                    |
| 19.4       | 232.6                    | 89.6       | 36.38                    | 159.8      | 8.268                    | 230        | 2.498                    |
| 21.2       | 220.5                    | 91.4       | 34.88                    | 161.6      | 7.991                    | 231.8      | 2.431                    |
| 23         | 209                      | 93.2       | 33.45                    | 163.4      | 7.726                    | 233.6      | 2.365                    |
| 24.8       | 198.3                    | 95         | 32.09                    | 165.2      | 7.47                     | 235.4      | 2.302                    |
| 26.6       | 199.1                    | 96.8       | 30.79                    | 167        | 7.224                    | 237.2      | 2.241                    |
| 28.4       | 178.5                    | 98.6       | 29.54                    | 168.8      | 6.998                    | 239        | 2.182                    |
| 30.2       | 169.5                    | 100.4      | 28.36                    | 170.6      | 6.761                    | 240.8      | 2.124                    |
| 32         | 161                      | 102.2      | 27.23                    | 172.4      | 6.542                    | 242.6      | 2.069                    |
| 33.8       | 153                      | 104        | 26.15                    | 174.2      | 6.331                    | 244.4      | 2.015                    |
| 35.6       | 145.4                    | 105.8      | 25.11                    | 176        | 6.129                    | 246.2      | 1.963                    |
| 37.4       | 138.3                    | 107.6      | 24.13                    | 177.8      | 5.933                    | 248        | 1.912                    |
| 39.2       | 131.5                    | 109.4      | 23.19                    | 179.6      | 5.746                    | 249.8      | 1.863                    |
| 41         | 125.1                    | 111.2      | 22.29                    | 181.4      | 5.565                    | 251.6      | 1.816                    |
| 42.8       | 119.1                    | 113        | 21.43                    | 183.2      | 5.39                     | 253.4      | 1.77                     |
| 44.6       | 113.4                    | 114.8      | 20.6                     | 185        | 5.222                    | 255.2      | 1.725                    |
| 46.4       | 108                      | 116.6      | 19.81                    | 186.8      | 5.06                     | 257        | 1.682                    |
| 48.2       | 102.8                    | 118.4      | 19.06                    | 188.6      | 4.904                    | 258.8      | 1.64                     |

# COMPONENTS TESTING

• Top view

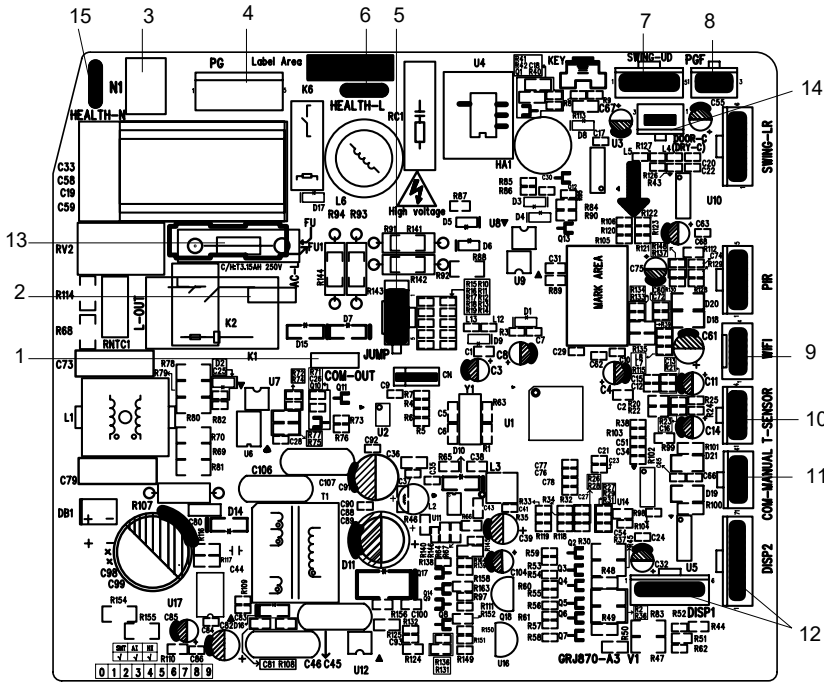

| No | Name   |
|----|--|
| 1  | Interface of communication wire for indoor unit and outdoor unit                 |
| 2  | Interface of live wire   |
| 3  | Interface of neutral wire  |
| 4  | Interface of fan   |
| 5  | Jumper cap   |
| 6  | Interface of health function live wire (only for the mode with this function)    |
| 7  | Up&down swing interface  |
| 8  | Feedback interface of indoor unit  |
| 9  | Interface of wifi  |
| 10 | Interface of tube temperature sensor   |
| 11 | Wired controller (only for the mode with this function)                          |
| 12 | Display interface  |
| 13 | Fuse   |
| 14 | Interface of gate control (only for the mode with this function)                 |
| 15 | Interface of health function neutral wire (only for the mode with this function) |

• Bottom view

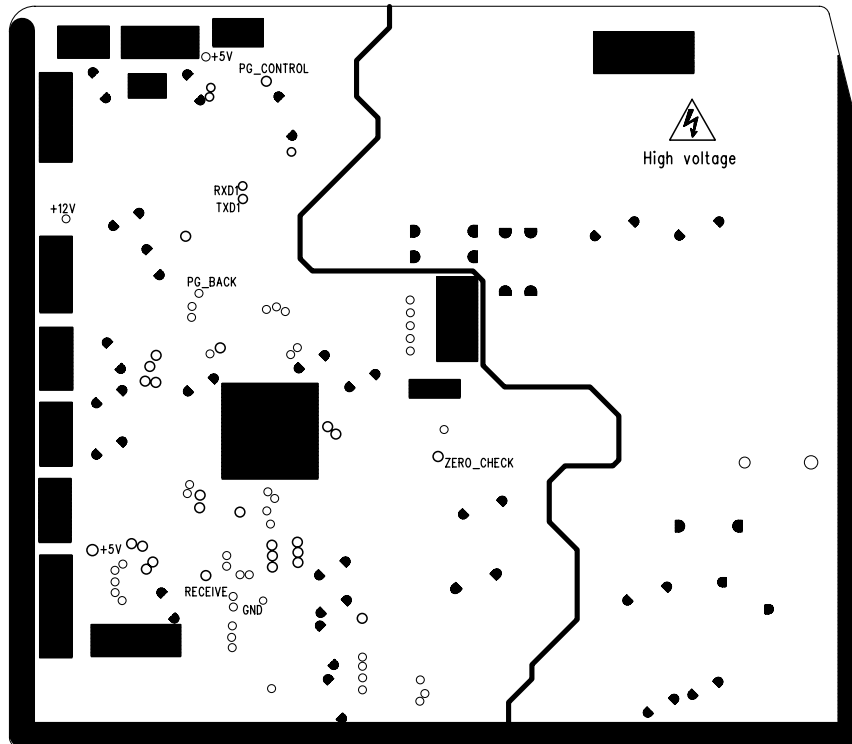
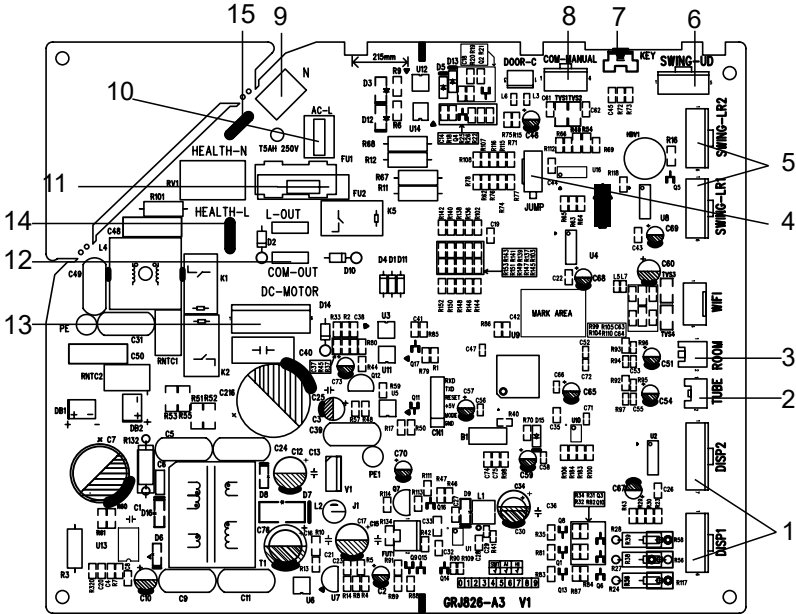

Figure 701

9-12k Indoor Unit Printed Circuit Board Identification

# COMPONENTS TESTING

Top view



| No. | Name   |
|-----|--|
| 1   | Display interface  |
| 2   | Inner tube temperature sensor  |
| 3   | Ambient temperature sensor   |
| 4   | Jumper cap   |
| 5   | Left&right swing interface   |
| 6   | Up&down swing interface  |
| 7   | Auto button  |
| 8   | Interface of wired controller  |
| 9   | Neutral wire   |
| 10  | Live wire  |
| 11  | Fuse   |
| 12  | Communication interface  |
| 13  | Wiring terminal for DC motor   |
| 14  | Interface of health function live wire (only for the mode with this function)    |
| 15  | Interface of health function neutral wire (only for the mode with this function) |

Bottom view

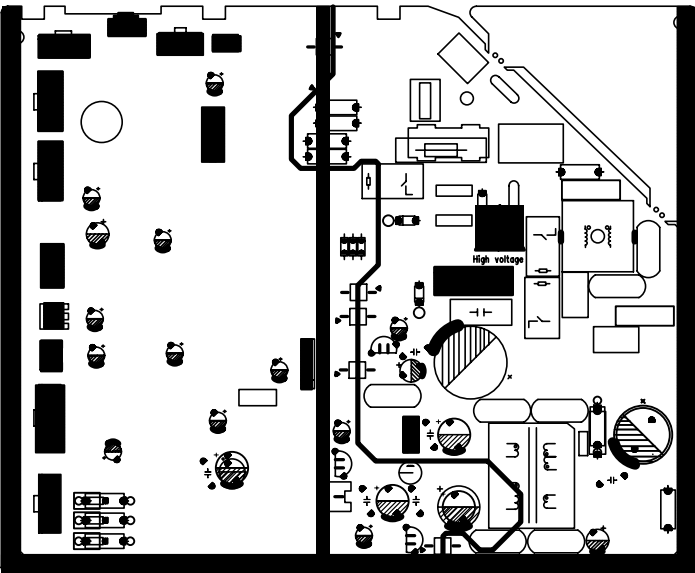
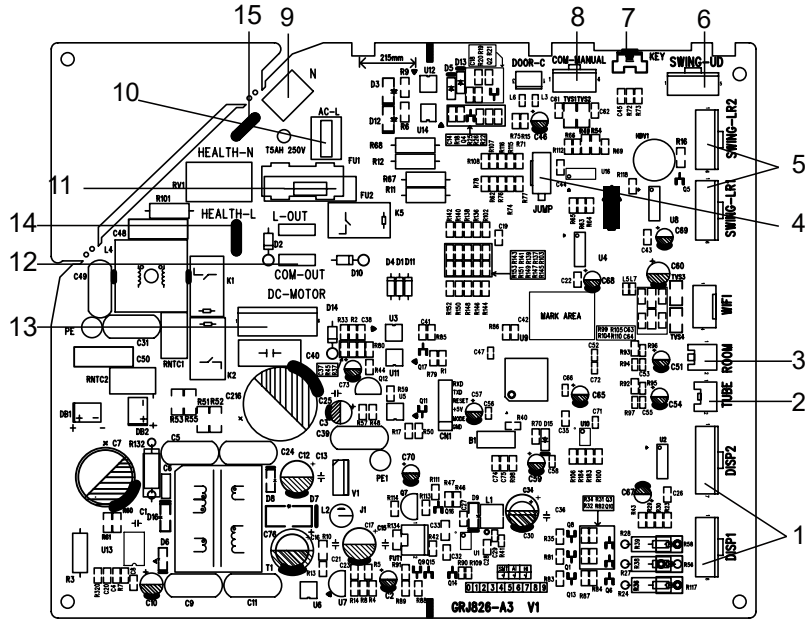

Figure 702

18-24k Indoor Unit Printed Circuit Board Identification

# COMPONENTS TESTING

Top view



| No. | Name  |
|-----|---|
| 1   | Display interface   |
| 2   | Inner tube temperature sensor   |
| 3   | Ambient temperature sensor  |
| 4   | Jumper cap  |
| 5   | Left&right swing interface  |
| 6   | Up&down swing interface   |
| 7   | Auto button   |
| 8   | Interface of wired controller   |
| 9   | Neutral wire  |
| 10  | Live wire   |
| 11  | Fuse  |
| 12  | Communication interface   |
| 13  | Wiring terminal for DC motor  |
| 14  | Interface of health function live wire<br>(only for the mode with this function)    |
| 15  | Interface of health function neutral wire<br>(only for the mode with this function) |

Bottom view

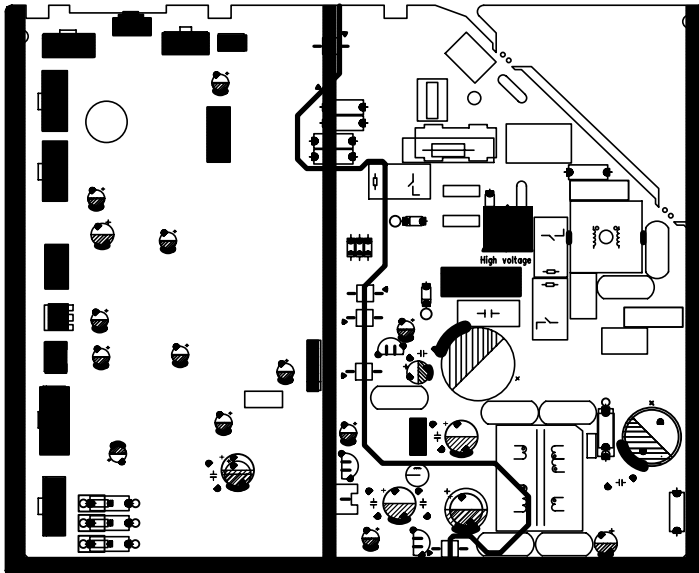
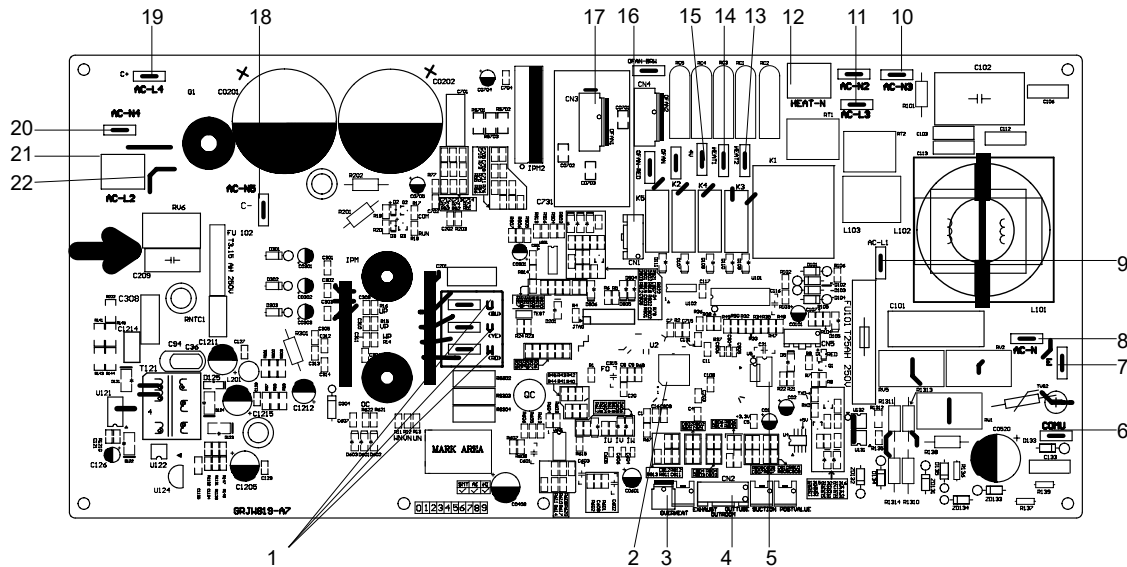

Figure 703

36k Indoor Unit Printed Circuit Board Identification

# COMPONENTS TESTING

## • Top view



| NO. | Name                               | NO. | Name  | NO. | Name   |
|-----|------------------------------------|-----|---|-----|--|
| 1   | Compressor output port             | 9   | Live wire   | 17  | Terminal of outdoor fan  |
| 2   | Master control chip                | 10  | Connection wire between boards of neutral wire connects AC-N4 | 18  | Connect the negative pole of external big electrolytic capacitor       |
| 3   | Overload temperature of compressor | 11  | Connection wire between boards of live wire connects AC-L2    | 19  | Connect the positive pole of external big electrolytic capacitor       |
| 4   | Temperature of temperature sensor  | 12  | Neutral wire terminal for electric heating                    | 20  | Wire connection terminal between boards of neutral wire connects AC-N3 |
| 5   | EEPROM                             | 13  | Live wire terminal for chassis electric heater                | 21  | Connection wire between boards of live wire connects AC-L3             |
| 6   | Communication wire port            | 14  | Live wire terminal for compressor electric heater             | 22  | Connect the middle position of external big electrolytic capacitor     |
| 7   | Earthing wire port                 | 15  | 4-way valve wiring terminal                                   | /   |  |
| 8   | Port of power neutral wire         | 16  | Terminal of electronic expansion valve                        | /   |  |

## • Bottom view

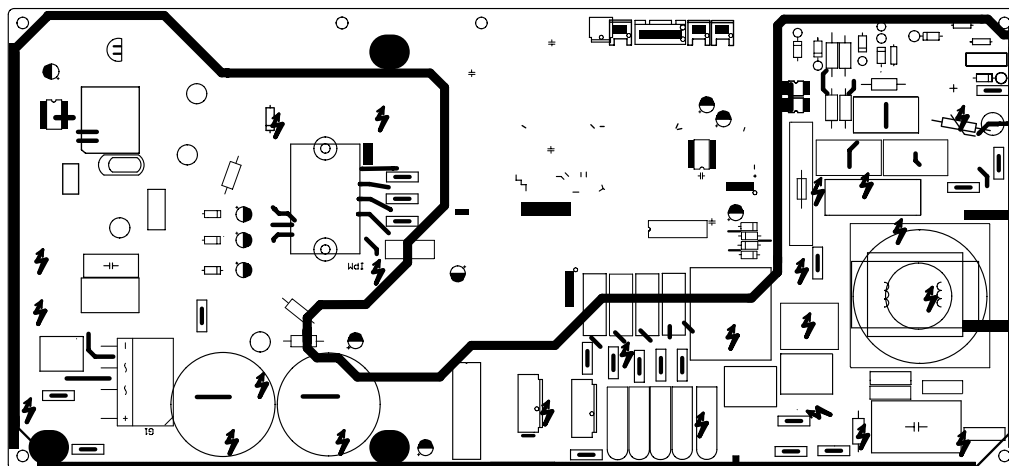

Figure 704

9-12k Outdoor Unit Printed Circuit Board Identification

# COMPONENTS TESTING

## Outdoor Unit

### • Top view

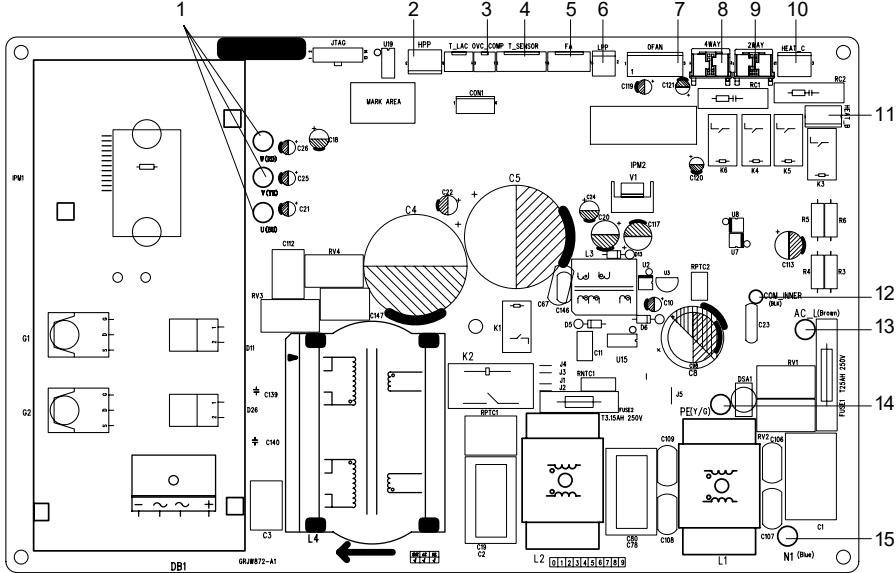

| No. | Name   |
|-----|--|
| 1   | Compressor three phase input interface       |
| 2   | Interface of system high pressure protection |
| 3   | Compressor overload protection interface     |
| 4   | Interface of temperature sensor              |
| 5   | Interface of electronic expansion valve      |
| 6   | Interface of system low pressure protection  |
| 7   | Interface of fan                             |
| 8   | 4-way valve interface                        |
| 9   | 2-way valve interface                        |
| 10  | Interface of electric heating for compressor |
| 11  | Interface of electric heating for chassis    |
| 12  | Communication interface                      |
| 13  | Interface of live wire                       |
| 14  | Interface of earthing wire                   |
| 15  | Interface of neutral wire                    |

### • Bottom view

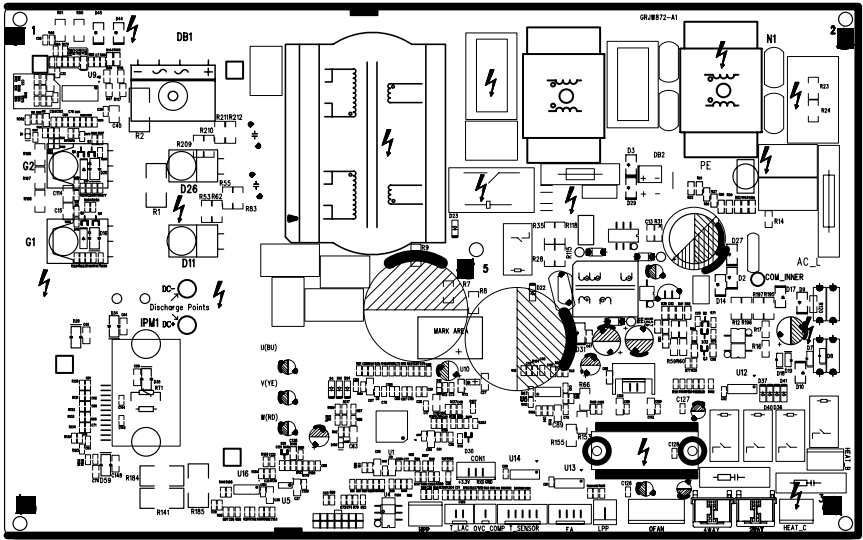

Figure 705

18-24k Outdoor Unit Printed Circuit Board Identification



# COMPONENTS TESTING

## • Top view

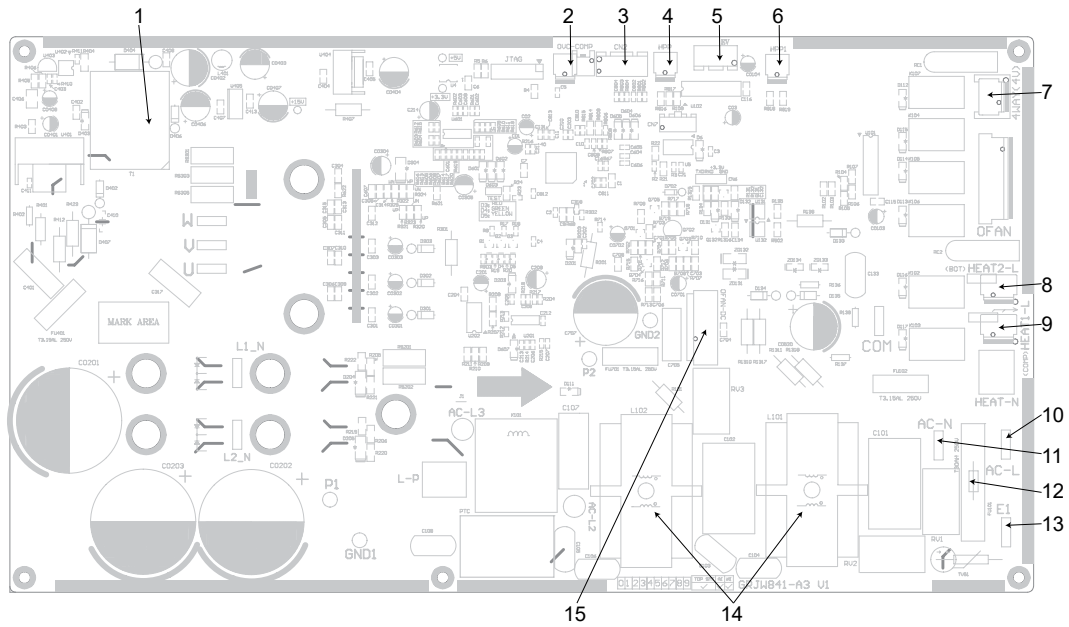

| No. | Name  | No. | Name                                       | No. | Name                            |
|-----|---|-----|--|-----|---------------------------------|
| 1   | High-frequency transformer T1                       | 6   | High pressure protection terminal HPP1     | 11  | Terminal of neutral wire        |
| 2   | Overload protection terminal of compressor OVC-COMP | 7   | Terminal of 4-way valve                    | 12  | Protective tube FU101           |
| 3   | Terminal of temp sensor CN2                         | 8   | Electric heater band of chassis HEAT2-L    | 13  | Terminal of ground wire         |
| 4   | High pressure protection terminal HPP               | 9   | Electric heater band of compressor HEAT1-L | 14  | Choke L 101 and L102            |
| 5   | Electronic expansion valve terminal EV              | 10  | Terminal of live wire                      | 15  | Terminal of outdoor fan OFAN-DC |

## • Bottom view

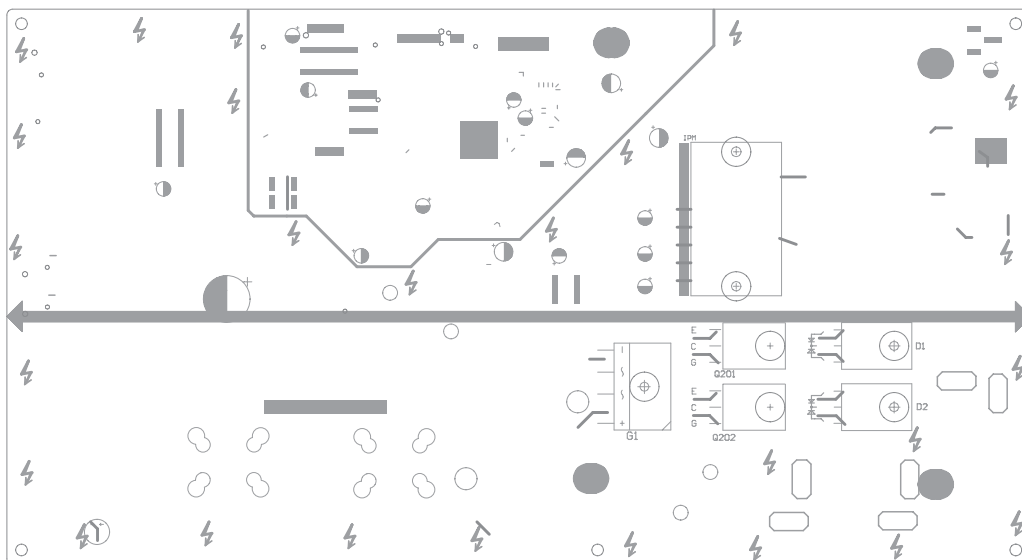

Figure 706

36k Outdoor Unit Printed Circuit Board Identification

# TROUBLESHOOTING

## Diagnostic Codes

| No. | Malfunction Name                                    | Display Method of Indoor Unit |   |                | Display Method of Outdoor Unit |   |                           | A/C status | Possible Causes   |   |
|-----|---|-------------------------------|---|----------------|--------------------------------|---|---------------------------|------------|---|---|
|     |   | Dual-8 Code Display           | Indicator Display (During blinking, ON 0.5s and OFF 0.5s) |                |                                | Indicator has 3 kinds of display status and during blinking, ON 0.5s and OFF 0.5s |                           |            |   |   |
|     |   |                               | Power Indicator   | Cool Indicator | Heating Indicator              | Yellow Indicator  | Red Indicator             |            |   | Green Indicator   |
| 1   | High Pressure Protection Of System                  | E1                            | OFF 3s and blink once                                     |                |                                |   |                           |            | During cooling and drying operation, except indoor fan operates, all loads stop operation.<br>During heating operation, the complete unit stops.  | Possible reasons:<br>1.Refrigerant was super-abundant;<br>2.Poor heat exchange (including filth blockage of heat exchanger and bad radiating environment );<br>Ambient temperature is too high. |
| 2   | Antifreezing protection                             | E2                            | OFF 3s and blink twice                                    |                |                                |   | OFF 1 s and blink 3 times |            | During cooling and drying operation, compressor and outdoor fan stop while indoor fan operates.   | 1.Poor air-return in indoor unit;<br>2.Fan speed is abnormal;<br>3.Evaporator is dirty.   |
| 3   | In Defect of refrigerant                            | F0                            |   |                |                                |   | OFF 1 s and blink 9 times |            | The Dual-8 Code Display will show F0 and the complete unit stops.   | 1.In defect of refrigerant;<br>2.Indoor evaporator temperature sensor works abnormally;<br>3. The unit has been plugged up somewhere.   |
| 4   | High Discharge temperature protection of compressor | E4                            | OFF 3s and blink 4 times                                  |                |                                |   | OFF 1s and blink 7 times  |            | During cooling and drying operation, compressor and outdoor fan stop while indoor fan operates. During heating operation, all loads stop.         | Please refer to the malfunction analysis (discharge protection, overload).  |
| 5   | Overcurrent protection                              | E5                            | OFF 3s and blink 6 times                                  |                |                                |   | OFF 1s and blink 5 times  |            | During cooling operation, compressor stops while indoor fan motor operates.<br>During heating operation, the complete unit stops.                 | 1. Supply voltage is unstable;<br>2. Supply voltage is too low and load is too high;<br>3. Evaporator is dirty.   |
| 6   | Communication malfunction                           | E6                            | OFF 3s and blink 6 times                                  |                |                                |   | Always on                 |            | During cooling operation, compressor stops while indoor fan motor operates.<br>During heating operation, the complete unit stops.                 | Refer to the corresponding malfunction analysis.  |
| 7   | High temperature resistant protection               | E8                            | OFF 3s and blink 8 times                                  |                |                                |   | OFF 1s and blink 6 times  |            | During cooling operation: compressor will stop while indoor fan will operate.<br>During heating operation, the complete unit stops.               | Refer to the malfunction analysis (overload, high temperature resistant).   |
| 8   | EEPROM malfunction                                  | EE                            |   |                | OFF 3s and blink 15 times      |   | OFF 1s and blink 11 times |            | During cooling and drying operation, compressor will stop while indoor fan will operate;<br>During heating operation, the complete unit will stop | Replace outdoor control panel AP1   |

# TROUBLESHOOTING

## Diagnostic Codes

| No. | Malfunction Name  | Display Method of Indoor Unit |   |                          | Display Method of Outdoor Unit |   |               | A/C status | Possible Causes   |  |
|-----|---|-------------------------------|---|--------------------------|--------------------------------|---|---------------|------------|---|--|
|     |   | Dual-8 Code Display           | Indicator Display (During blinking, ON 0.5s and OFF 0.5s) |                          |                                | Indicator has 3 kinds of display status and during blinking, ON 0.5s and OFF 0.5s |               |            |   |  |
|     |   |                               | Power Indicator   | Cool Indicator           | Heating Indicator              | Yellow Indicator  | Red Indicator |            |   | Green Indicator  |
| 9   | Limit/ decrease frequency due to high temperature             | EU                            |   | OFF 3s and blink 6 times | OFF 3s and blink 6 times       |   |               |            | All loads operate normally, while operation frequency for compressor is decreased   | Discharging after the complete unit is de-energized for 20mins, check whether the thermal grease on IPM Module of outdoor control the radiator is inserted tightly. If its no use, please replace control panel AP1.   |
| 10  | Malfunction protection of jumper cap                          | C5                            | OFF 3s and blink 15 times                                 |                          |                                |   |               |            | Wireless remote receiver and button are effective, but can not dispose the related command  | 1.No jumper cap insert on mainboard.<br>2.Incorrect insert of jumper cap.<br>3.Jumper cap damaged.<br>4.Abnormal detecting circuit of mainboard.   |
| 11  | Gathering Refrigerant   | F0                            | OFF 3s and blink once                                     | OFF 3s and blink once    |                                | OFF 1s and blink 17 times   |               |            | When the outdoor unit receive signal of Gathering refrigerant ,the system will be forced to run under cooling mode for gathering refrigerant                              | Nominal cooling mode   |
| 12  | Indoor ambient temperature sensor is open/ short circuited    | F2                            |   | OFF 3s and blink once    |                                |   |               |            | During cooling and drying operation, indoor unit operates while other loads will stop; during heating operation, the complete unit will stop operation.                   | 1.Loosening or bad contact of indoor ambient temp. sensor and mainboard terminal.<br>2.Components in mainboard fell down leads short circuit.<br>3.Indoor ambient temp. sensor damaged.(check with sensor resistance value chart)<br>4.Mainboard damaged.            |
| 13  | indoor evaporator temperature sensor is open/ short circuited | F2                            |   | OFF 3s and blink twice   |                                |   |               |            | AC stops operation once reaches the setting temperature. Cooling, drying: internal fan motor stops operation while other loads stop operation; heating: AC stop operation | 1.Loosening or bad contact of Indoor evaporator temp. sensor and mainboard terminal.<br>2.Components on the mainboard fall down leads short circuit<br>3.Indoor evaporator temp. sensor damaged.(check temp. sensor value chart for testing)<br>4.Mainboard damaged. |

# TROUBLESHOOTING

## Diagnostic Codes

| No. | Malfunction Name  | Display Method of Indoor Unit |   |                              | Display Method of Outdoor Unit |   |                          | A/C status   | Possible Causes  |                 |
|-----|---|-------------------------------|---|------------------------------|--------------------------------|---|--------------------------|--|--|-----------------|
|     |   | Dual-8 Code Display           | Indicator Display (During blinking, ON 0.5s and OFF 0.5s) |                              |                                | Indicator has 3 kinds of display status and during blinking, ON 0.5s and OFF 0.5s |                          |  |  |                 |
|     |   |                               | Power Indicator   | Cool Indicator               | Heating Indicator              | Yellow Indicator  | Red Indicator            |  |  | Green Indicator |
| 14  | outdoor ambient temperature sensor is open/ short circuited   | F3                            |   | OFF 3s and blink 3 times     |                                |   | OFF 1s and blink 6 times | During cooling and drying operating, compressor stops while indoor fan operates; During heating operation, the complete unit will stop operation   | Outdoor temperature sensor hasn't been connected well or is damaged. Please check it by referring to the resistance table for temperature sensor)  |                 |
| 15  | outdoor condenser temperature sensor is open/ short circuited | F4                            |   | OFF 3s and blink 4 times     |                                |   | OFF 1s and blink 5 times | During cooling and drying operation, compressor stops while indoor fan will operate; During heating operation, the complete unit will stop operation.  | Outdoor temperature sensor hasn't been connected well or is damaged. Please check it by referring to the resistance table for temperature sensor   |                 |
| 16  | outdoor discharge temperature sensor is open/ short circuited | F5                            |   | OFF 3s and blink for 5 times |                                |   | OFF 1s and blink 7 times | During cooling and drying operation, compressor will stop after operating for about 3 mins, while indoor fan will operate; During heating operation, the complete unit will stop after operating for about 3 mins. | 1. Outdoor temperature sensor hasn't been connected well or is damaged. Please check it by referring to the resistance table for temperature sensor<br>2. The head of temperature sensor hasn't been inserted into the copper tube |                 |
| 17  | limit/ decrease frequency due to overload                     | F6                            |   | OFF 3s and blink for 6 times |                                |   | OFF 1s and blink 3 times | All loads operate normally, while operation frequency for compressor is decreased  | Refer to the malfunction analysis (overload, high temperature resistant)   |                 |
| 18  | decrease frequency due to overcurrent                         | F8                            |   | OFF 3s and blink 8 times     |                                |   | OFF 1s and blink once    | All loads operate normally, while operation frequency for compressor is decreased  | The input supply voltage is too low; System pressure is too high and overload  |                 |
| 19  | decrease frequency due to high air discharge                  | F9                            |   | OFF 3s and blink 9 times     |                                |   | OFF 1s and blink twice   | All loads operate normally, while operation frequency for compressor is decreased  | Overload or temperature is too high; refrigerant is insufficient. Malfunction of electric expansion valve (EKV)  |                 |
| 20  | limit/ decrease frequency due to antifreezing                 | FH                            |   | OFF 3s and blink 2 times     | OFF 3s and blink 2 times       |   | OFF 1s and blink 4 times | All loads operate normally, while operation frequency for compressor is decreased  | Poor air-return in indoor unit or fan speed is too low   |                 |

# TROUBLESHOOTING

## Diagnostic Codes

| No. | Malfunction Name                           | Display Method of Indoor Unit |   |  | Display Method of Outdoor Unit         |   |               | A/C status | Possible Causes   |   |
|-----|--|-------------------------------|---|--|--|---|---------------|------------|---|---|
|     |  | Dual-8 Code Display           | Indicator Display (During blinking, ON 0.5s and OFF 0.5s) |  |  | Indicator has 3 kinds of display status and during blinking, ON 0.5s and OFF 0.5s |               |            |   |   |
|     |  |                               | Power Indicator   | Cool Indicator                         | Heating Indicator                      | Yellow Indicator  | Red Indicator |            |   | Green Indicator   |
| 21  | voltage for DC bus bar is too high high    | PH                            |   | OFF 3s and blink 11 times              |  | OFF 1s and blink 13 times   |               |            | During cooling and drying operation, compressor will stop while indoor fan will operate; During heating operation, the complete unit will stop operation. | 1.Measure the voltage of position L and N on wiring board (XT), if the voltage is higher than 265VAC, turn on the unit after the supply voltage is increased to the normal range.<br>2.If the AC input is normal, measure the voltage of electrolytic capacitor C on control panel (AP1), if its normal, theres malfunction for the circuit, please replace the control panel (AP1) |
| 22  | voltage of DC bus- bar is too low          | PL                            |   |  | OFF 3s and blink 21 times              | OFF 1s and blink 12 times   |               |            | During cooling and drying operation, compressor will stop while indoor fan will operate; During heating operation, the complete unit will stop            | 1.Measure the voltage of position L and N on wiring board (XT), if the voltage is higher than 150VAC, turn on the unit after the supply voltage is increased to the normal range.<br>2.If the AC input is normal, measure the voltage of electrolytic capacitor C on control panel (AP1), if its normal, there is a malfunction for the circuit, replace the control panel (AP1)    |
| 23  | compressor min frequency in test state     | P0                            |   | during blinking ON 0.25s and OFF 0.25s | during blinking ON 0.25s and OFF 0.25s |   |               |            |   | Showing during nominal cooling or nominal heating test  |
| 24  | compressor rated frequency in test state   | P1                            |   | during blinking ON 0.25s and OFF 0.25s | during blinking ON 0.25s and OFF 0.25s |   |               |            |   | Showing during middle cooling or middle heating test  |
| 25  | compressor maximum frequency in test state | P2                            |   | during blinking ON and OFF and 0.25s   | during blinking ON and OFF and 0.25s   |   |               |            |   | Showing during max. cooling or max. heating test  |

# TROUBLESHOOTING

## Diagnostic Codes

| No. | Malfunction Name  | Display Method of Indoor Unit |   |  | Display Method of Outdoor Unit                 |   |               | A/C status  | Possible Causes  |                 |
|-----|---|-------------------------------|---|--|--|---|---------------|---|--|-----------------|
|     |   | Dual-8 Code Display           | Indicator Display (During blinking, ON 0.5s and OFF 0.5s) |  |  | Indicator has 3 kinds of display status and during blinking, ON 0.5s and OFF 0.5s |               |   |  |                 |
|     |   |                               | Power Indicator   | Cool Indicator                                 | Heating Indicator                              | Yellow Indicator  | Red Indicator |   |  | Green Indicator |
| 26  | compressor intermediate frequency in test state                               | P3                            |   | during blinking ON and 0.25s and OFF and 0.25s | during blinking ON and 0.25s and OFF and 0.25s |   |               |   | Showing during middle cooling or middle heating test   |                 |
| 27  | overcurrent protection of phase current for compressor                        | P5                            |   | OFF 3s and blink 15 times                      |  |   |               | During cooling and drying operation, compressor will stop while indoor fan will operate; During heating operation, the complete unit will stop operation. | Refer to the malfunction analysis (IPM protection, loss of synchronism protection and overcurrent protection of phase current for compressor).   |                 |
| 28  | charging malfunction of capacitor   | PU                            |   |  | OFF 3s and blink 17 times                      |   |               | During cooling and drying operation, compressor will stop while indoor fan will operate; During heating operation, the complete unit will stop            | Refer to the part three—charging malfunction analysis of capacitor   |                 |
| 29  | malfunction of module temperature sensor circuit                              | P7                            |   |  | OFF 3s and blink 18 times                      | s   |               | During cooling and drying operation, compressor will stop while indoor fan will operate; During heating operation, the complete unit will stop            | Replace outdoor control panel AP1  |                 |
| 30  | module high temperature protection  | P8                            |   |  | OFF 3s and blink 19 times                      |   |               | During cooling operation, compressor will stop while indoor fan will operate; During heating operation, the complete unit will stop                       | After the complete unit is de-energized for 20mins, check whether the thermal grease on IPM Module of outdoor control panel AP is sufficient and whether the radiator is inserted tightly. If no faults found, replace control panel AP1 |                 |
| 31  | decrease frequency due to high temperature resistant during heating operation | H0                            |   |  | OFF 3s and blink 10 times                      |   |               | All loads operate normally, while operation frequency for compressor is decreased   | Refer to the malfunction analysis (overload, high temperature resistant)   |                 |
| 32  | static dedusting protection   | H2                            |   |  | OFF 3s and blink twice                         |   |               |   |  |                 |

# TROUBLESHOOTING

## Diagnostic Codes

| No. | Malfunction Name                             | Display Method of Indoor Unit |   |                          | Display Method of Outdoor Unit |   |               | A/C status | Possible Causes   |   |
|-----|--|-------------------------------|---|--------------------------|--------------------------------|---|---------------|------------|---|---|
|     |  | Dual-8 Code Display           | Indicator Display (During blinking, ON 0.5s and OFF 0.5s) |                          |                                | Indicator has 3 kinds of display status and during blinking, ON 0.5s and OFF 0.5s |               |            |   |   |
|     |  |                               | Power Indicator   | Cool Indicator           | Heating Indicator              | Yellow Indicator  | Red Indicator |            |   | Green Indicator   |
| 33  | overload protection for compressor           | H3                            |   |                          | OFF 3s and blink 3 times       | OFF 1s and blink 8 times  |               |            | During cooling and drying operation, compressor will stop while indoor fan will operate; During heating operation, the complete unit will stop operation. | 1.Wiring terminal OVC-COMP is loosened. In normal state, the resistance for this terminal should be less than 1ohm.<br>2.Refer to the malfunction analysis ( discharge protection, overload)        |
| 34  | system is abnormal                           | H4                            |   | OFF 3s and blink 4 times | OFF 1s and blink 6 times       |   |               |            | During cooling and drying operation, compressor will stop while indoor fan will operate; During heating operation, the complete unit will stop operation. | Refer to the malfunction analysis (overload, high temperature resistant)  |
| 35  | IPM protection                               | H5                            |   | OFF 3S and blink 5 times | OFF 1s and blink 4 times       |   |               |            | During cooling and drying operation, compressor will stop while indoor fan will operate; During heating operation, the complete unit will stop operation. | Refer to the malfunction analysis (IPM protection, loss of synchronism protection and overcurrent protection of phase current for compressor.   |
| 36  | module temperate is too high                 | H5                            |   | OFF 3s and blink 5 times | OFF 1s and blink 10 times      |   |               |            |   |   |
| 37  | internal motor ( fan motor) does not operate | H6                            | OFF 3s and blink 11 times                                 |                          |                                |   |               |            | Internal fan motor, external fan motor, compressor and electric heater stop operation,guide louver stops at present location.                             | 1. Bad contact of DC motor feedback terminal.<br>2. Bad contact of DC motor control end.<br>3.Fan motor is stalling.<br>4. Motor malfunction.<br>5. Malfunction of mainboard rev detecting circuit. |
| 38  | desynchronizing of compressor                | H7                            |   |                          | OFF 3s and blink 7 times       |   |               |            | During cooling and drying operation, compressor will stop while indoor fan will operate; During heating operation, the complete unit will stop operation. | Refer to the malfunction analysis (IPM protection, loss of synchronism protection and overcurrent protection of phase current for compressor.   |
| 39  | PFC protection                               | HC                            |   |                          | OFF 3s and blink 6 times       | OFF 1s and blink 14 times   |               |            | During cooling and drying operation, compressor will stop while indoor fan will operate; During heating operation, the complete unit will stop operation. | Refer to the malfunction analysis   |

# TROUBLESHOOTING

## Diagnostic Codes

| No. | Malfunction Name  | Display Method of Indoor Unit |   |                           | Display Method of Outdoor Unit |   |                           | A/C status  | Possible Causes   |                 |
|-----|---|-------------------------------|---|---------------------------|--------------------------------|---|---------------------------|---|---|-----------------|
|     |   | Dual-8 Code Display           | Indicator Display (During blinking, ON 0.5s and OFF 0.5s) |                           |                                | Indicator has 3 kinds of display status and during blinking, ON 0.5s and OFF 0.5s |                           |   |   |                 |
|     |   |                               | Power Indicator   | Cool Indicator            | Heating Indicator              | Yellow Indicator  | Red Indicator             |   |   | Green Indicator |
| 40  | outdoor DC fan motor malfunction                              | L3                            | OFF 3s and blink 23 times                                 |                           |                                |   | OFF 1s and blink 14 times | Outdoor DC fan motor malfunction lead to compressor stop operation,   | DC fan motor malfunction or system blocked or the connector loosed  |                 |
| 41  | power protection  | L9                            | OFF 3s and blink 20 times                                 |                           |                                |   | OFF 1s and blink 9 times  | compressor operation stops and Outdoor fan motor will stop 30s later , 3 minutes later fan motor and compressor will restart                                  | To protect the electrical components when detect high power   |                 |
| 42  | indoor unit and outdoor unit don't match                      | LP                            | OFF 3s and blink 19 times                                 |                           |                                |   | OFF 1s and blink 16 times | compressor and Outdoor fan motor don't work   | Indoor unit and outdoor unit don't match  |                 |
| 43  | failure start up  | LC                            |   |                           | OFF 3s and blink 11 times      |   |                           | During cooling and drying operation, compressor will stop while indoor fan will operate; During heating operation, the complete unit will stop operation.     | Refer to the malfunction analysis   |                 |
| 44  | malfunction of phase current detection circuit for compressor | U1                            |   |                           | OFF 3s and blink 13 times      |   |                           | During cooling and drying operation, compressor will stop while indoor fan will operate; During heating operation, the complete unit will stop                | Replace outdoor control panel AP1   |                 |
| 45  | malfunction of voltage dropping for DC bus bar                | U3                            |   |                           | OFF 3s and blink 20 times      |   |                           | During cooling and drying operation, compressor will stop while indoor fan will operate; During heating operation, the complete unit will stop                | Supply voltage is unstable  |                 |
| 46  | malfunction of complete units current detention               | U5                            |   | OFF 3s and blink 13 times |                                |   |                           | During cooling and drying operation, the compressor will stop while indoor fan will operate; During heating operating, the complete unit will stop operation. | There's a circuit malfunction on outdoor units control panel AP1, replace the outdoor units control panel AP1.                  |                 |
| 47  | the four-way valve is abnormal                                | U7                            |   | OFF 3s and blink 20 times |                                |   |                           | If this malfunction occurs during heating operation, the complete unit will stop operation.   | 1. Supply voltage is lower than AC175V;<br>2. Wiring terminal 4V is loosened or broken;<br>3. 4V is damaged, please replace 4V. |                 |



# TROUBLESHOOTING

## Diagnostic Codes

| No. | Malfunction Name                                   | Display Method of Indoor Unit |   |                        | Display Method of Outdoor Unit |   |                           | A/C status              | Possible Causes  |  |
|-----|--|-------------------------------|---|------------------------|--------------------------------|---|---------------------------|-------------------------|--|--|
|     |  | Dual-8 Code Display           | Indicator Display (During blinking, ON 0.5s and OFF 0.5s)   |                        |                                | Indicator has 3 kinds of display status and during blinking, ON 0.5s and OFF 0.5s |                           |                         |  |  |
|     |  |                               | Power Indicator   | Cool Indicator         | Heating Indicator              | Yellow Indicator  | Red Indicator             |                         |  | Green Indicator  |
| 48  | zero crossing malfunction of outdoor unit          | U9                            | OFF 3s and blink 18 times                                   |                        |                                |   |                           |                         | During cooling operation, compressor will stop while indoor fan will operate; during heating, the complete unit will stop operation. | Replace outdoor control panel AP1  |
| 49  | frequency limiting (power)                         |                               |   |                        |                                |   | OFF 1 and blink 13 times  |                         |  |  |
| 50  | compressor running                                 |                               |   |                        |                                |   | OFF 1s and blink 13 times |                         |  |  |
| 51  | the temperature for turning on the unit is reached |                               |   |                        |                                |   | OFF 1s and blink 8 times  |                         |  |  |
| 52  | frequency limiting (module temperature)            |                               |   |                        |                                |   | OFF 1s and blink 11 times |                         |  |  |
| 53  | normal communication                               |                               |   |                        |                                |   |                           | OFF 0.5s and blink once |  |  |
| 54  | defrosting   | H1                            | OFF 3s and blink once (during blinking, ON 10S AND OFF 0.5S | OFF 1s and blink twice |                                |   |                           |                         | Defrosting will occur in heating mode. Compressor will operate while indoor fan will stop operation.                                 | Its the normal state   |
| 55  | malfunction of zero-cross detection circuit        | U8                            |   |                        |                                |   |                           |                         | The Complete Unit Stops  | 1. Power supply is abnormal<br>2. Detection circuit of indoor control mainboard is abnormal. |
| 56  | Malfunction of detecting plate (WIFI)              | JF                            |   |                        |                                |   |                           |                         |  |  |

# TROUBLESHOOTING

## Malfunction of Temperature Sensor F1, F2

Indoor unit

### (1) Malfunction of Temperature Sensor F1, F2

Main detection points:

- Is the wiring terminal between the temperature sensor and the controller loosened or poorly contacted?
- Is there short circuit due to trip-over of the parts?
- Is the temperature sensor broken?
- Is mainboard broken?

Malfunction diagnosis process:

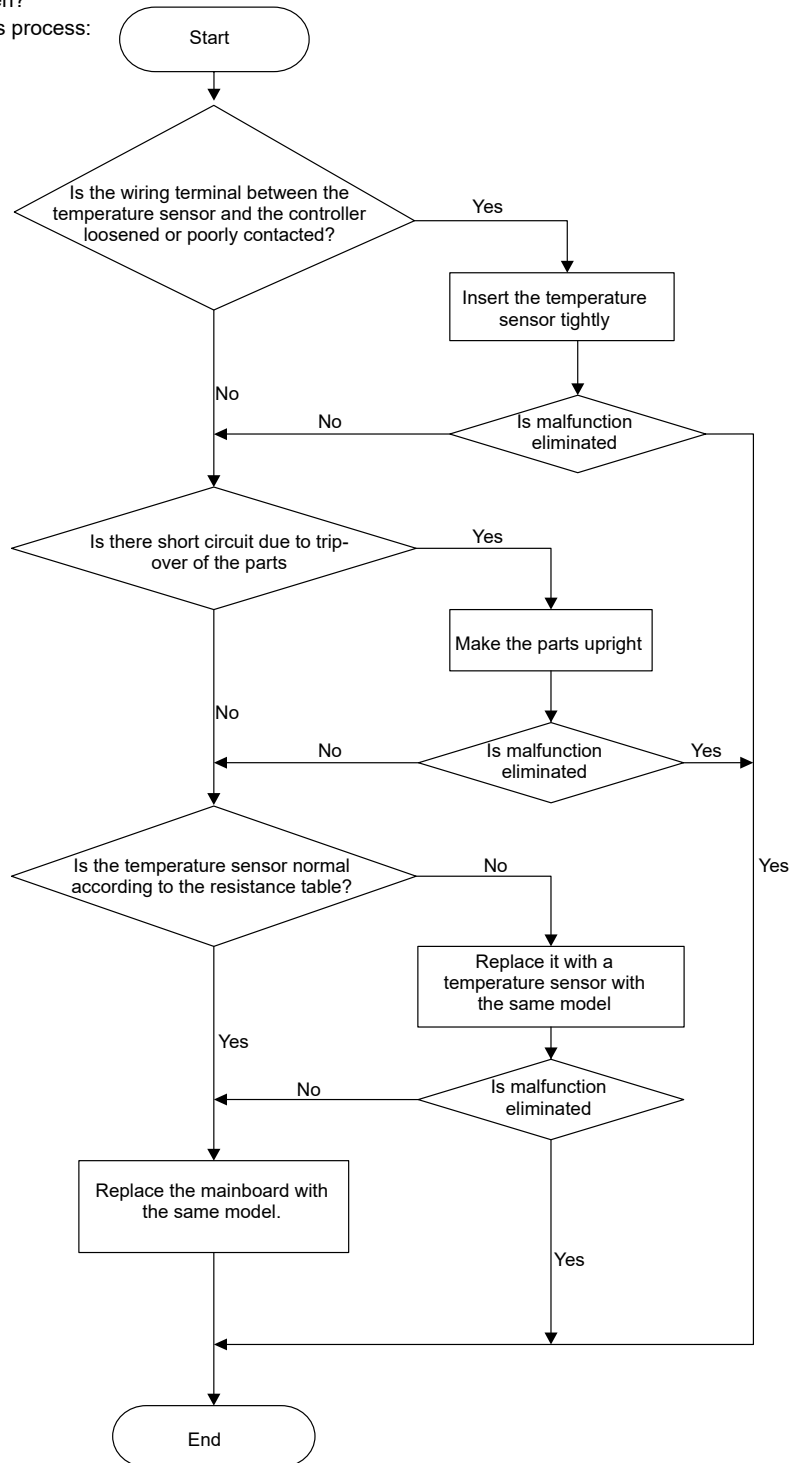

# TROUBLESHOOTING

## 9-12k Malfunction of blocked Protection of IDU Fan Motor H6

### 2. Malfunction of Blocked Protection of IDU Fan Motor H6

Main detection points:

- Smoothly the control terminal of PG motor connected tightly?
- Smoothly the feedback interface of PG motor connected tightly?
- The fan motor cant operate?
- The motor is broken?
- Detectioncircuit of the mainboard is defined abnormal?

Malfunction diagnosis process:

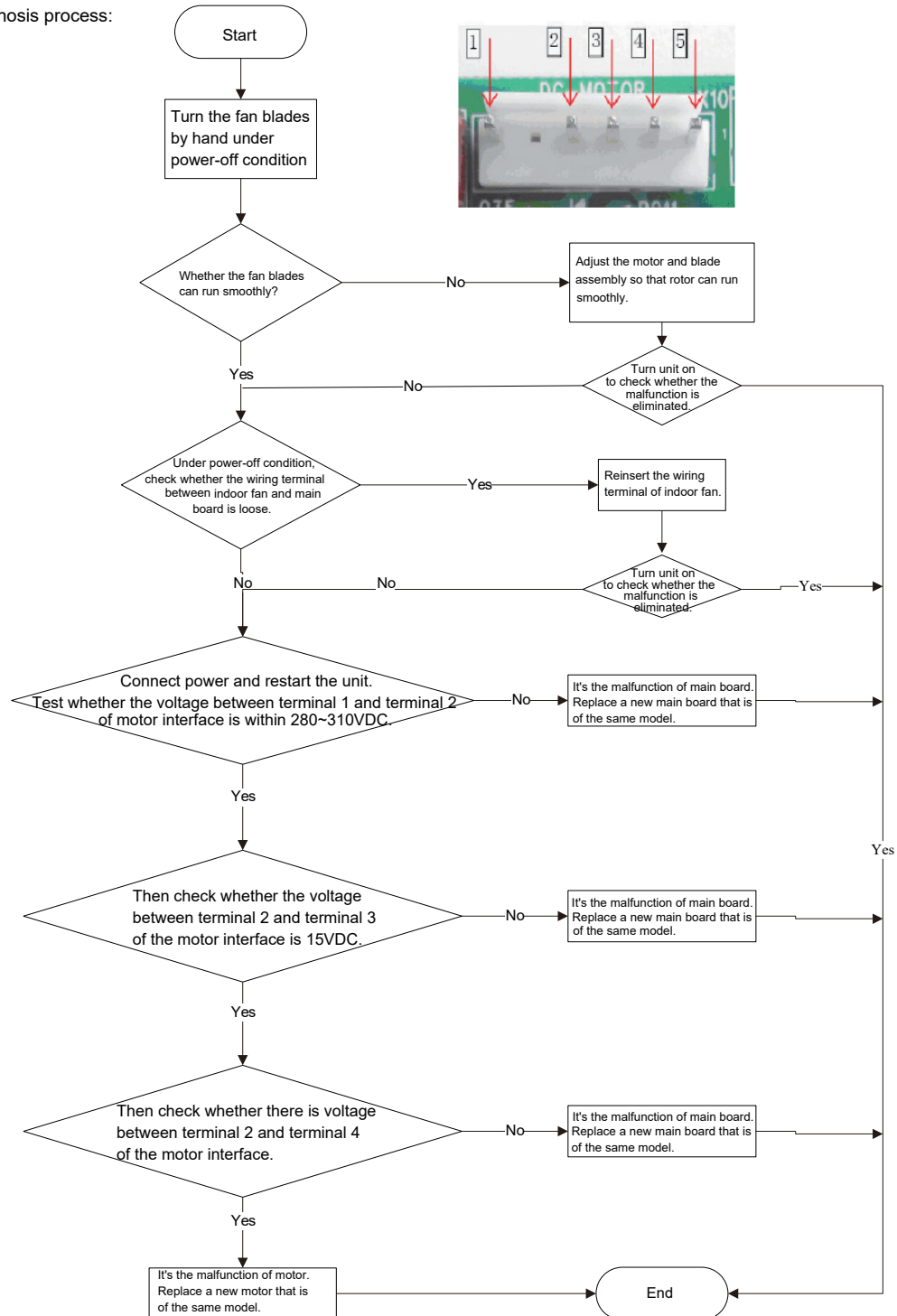

# TROUBLESHOOTING

## 18-36k Malfunction of blocked Protection of IDU Fan Motor H6

### 2. Malfunction of Blocked Protection of IDU Fan Motor H6

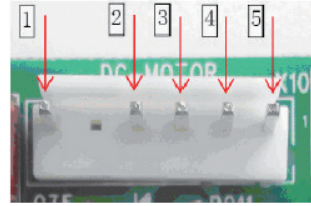
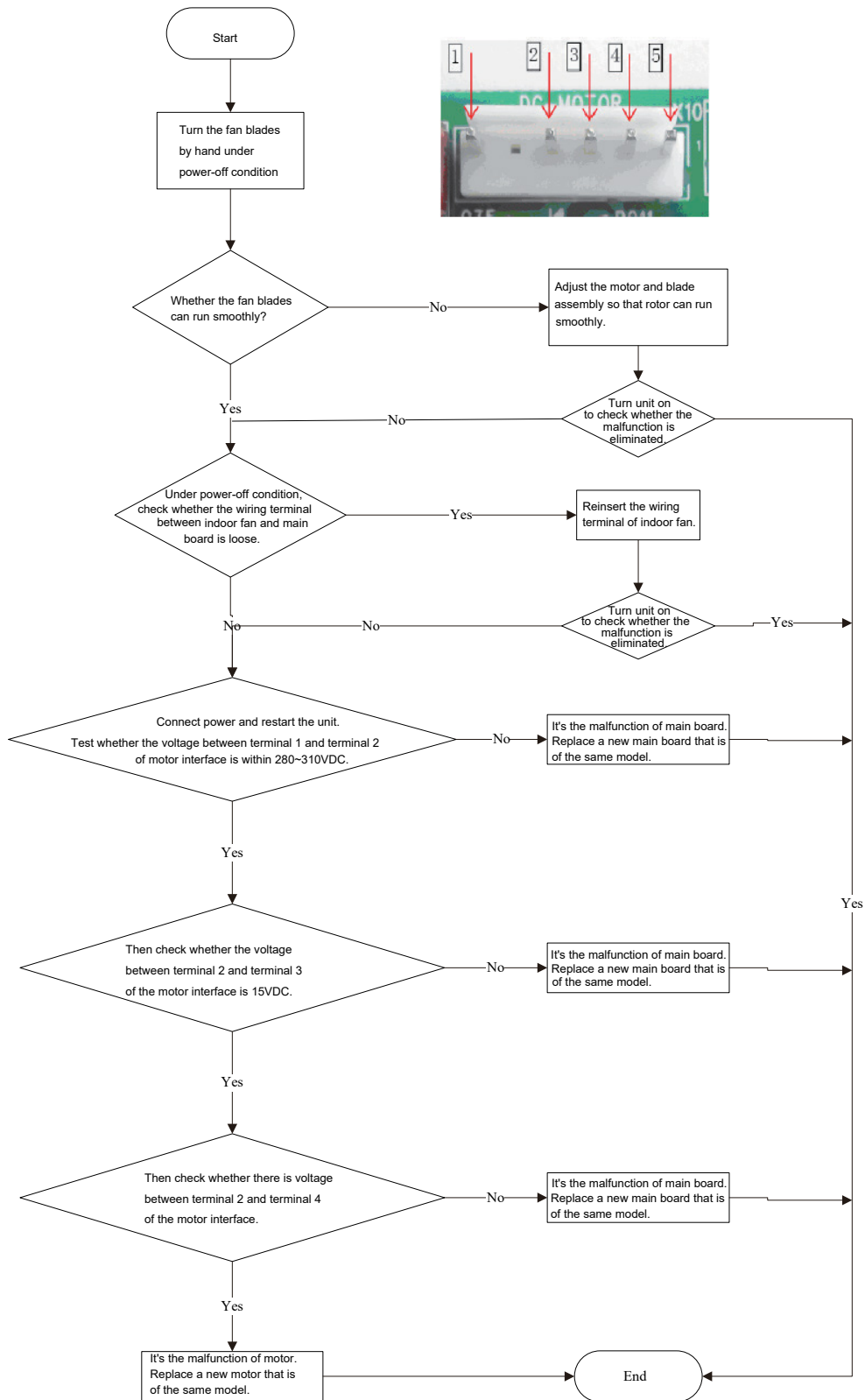

# TROUBLESHOOTING

## Malfunction of Protection of Jumper Cap C5

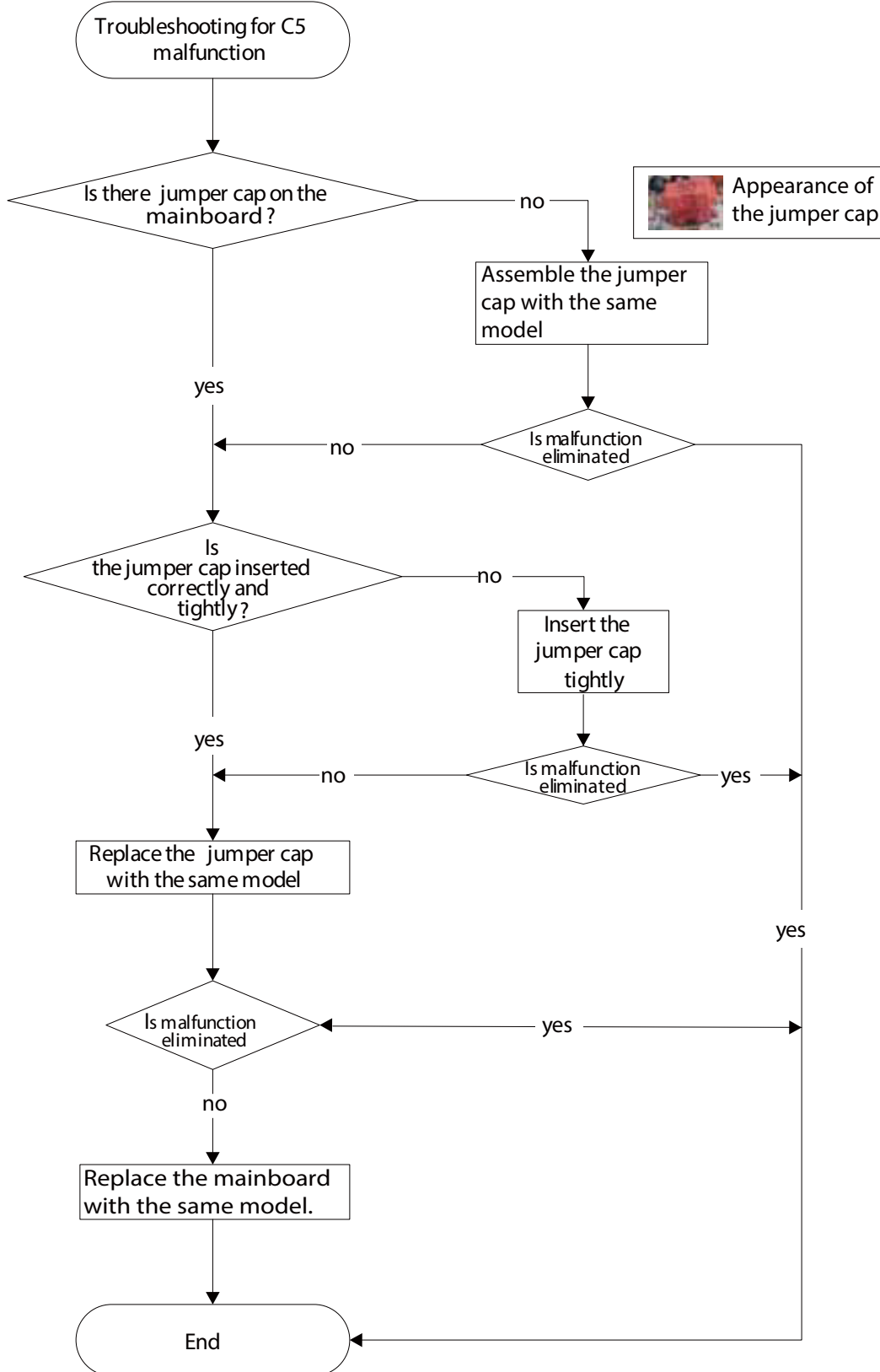

---

# TROUBLESHOOTING

## Malfunction of IDU Fan Motor U8

Main detection points:

- Instant energization after de-energization while the capacitor discharges slowly?
- The zero-cross detection circuit of the mainboard is defined abnormal?

Malfunction diagnosis process:

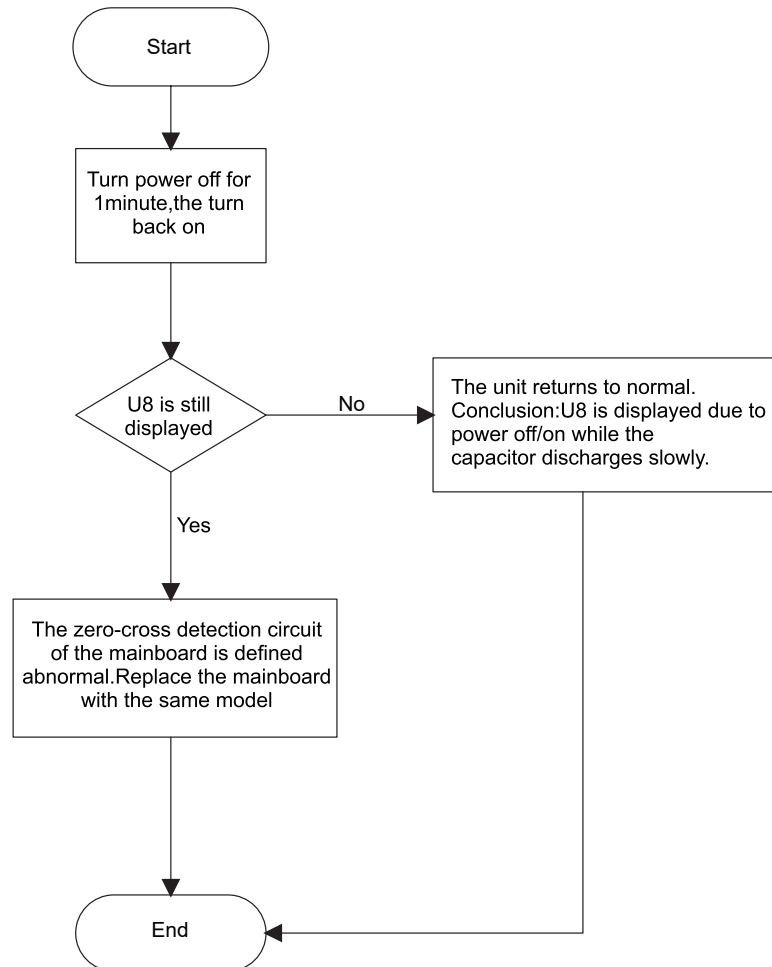

# TROUBLESHOOTING

## Overcurrent Protection E5

### Malfunction of Overcurrent Protection E5

Main detection points:

- Is the supply voltage unstable with big fluctuation?
- Is the supply voltage too low with overload?
- Hardware trouble?

Malfunction diagnosis process:

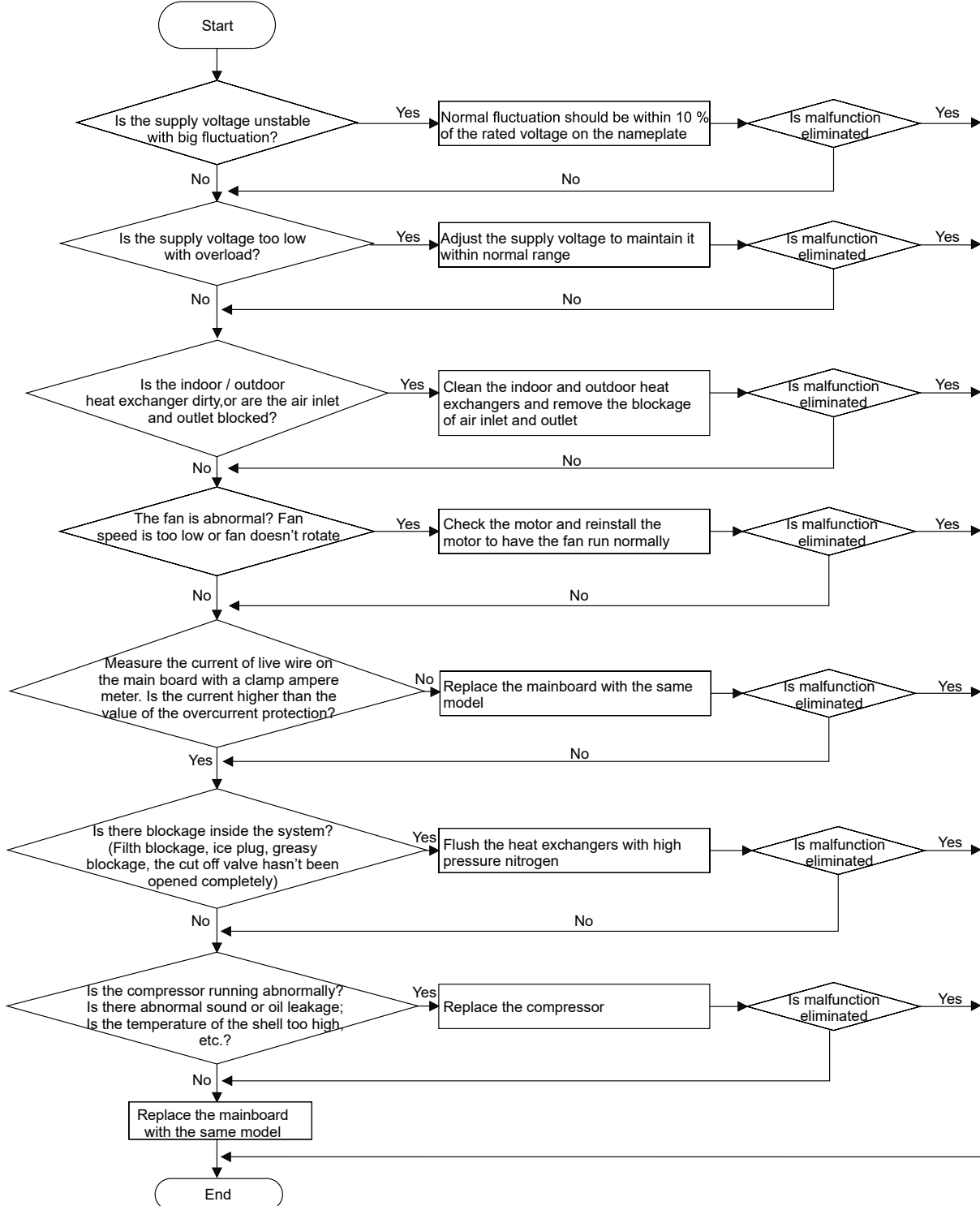

# TROUBLESHOOTING

## Malfunction of Communication E6

### Malfunction of communication E6

Main detection points:

- Check if the connection wire and the built-in wiring of indoor and outdoor unit are connected well and without damage;
- If the communication circuit of indoor mainboard is damaged? If the communication circuit of outdoor mainboard (AP1) is damaged?

Malfunction diagnosis process:

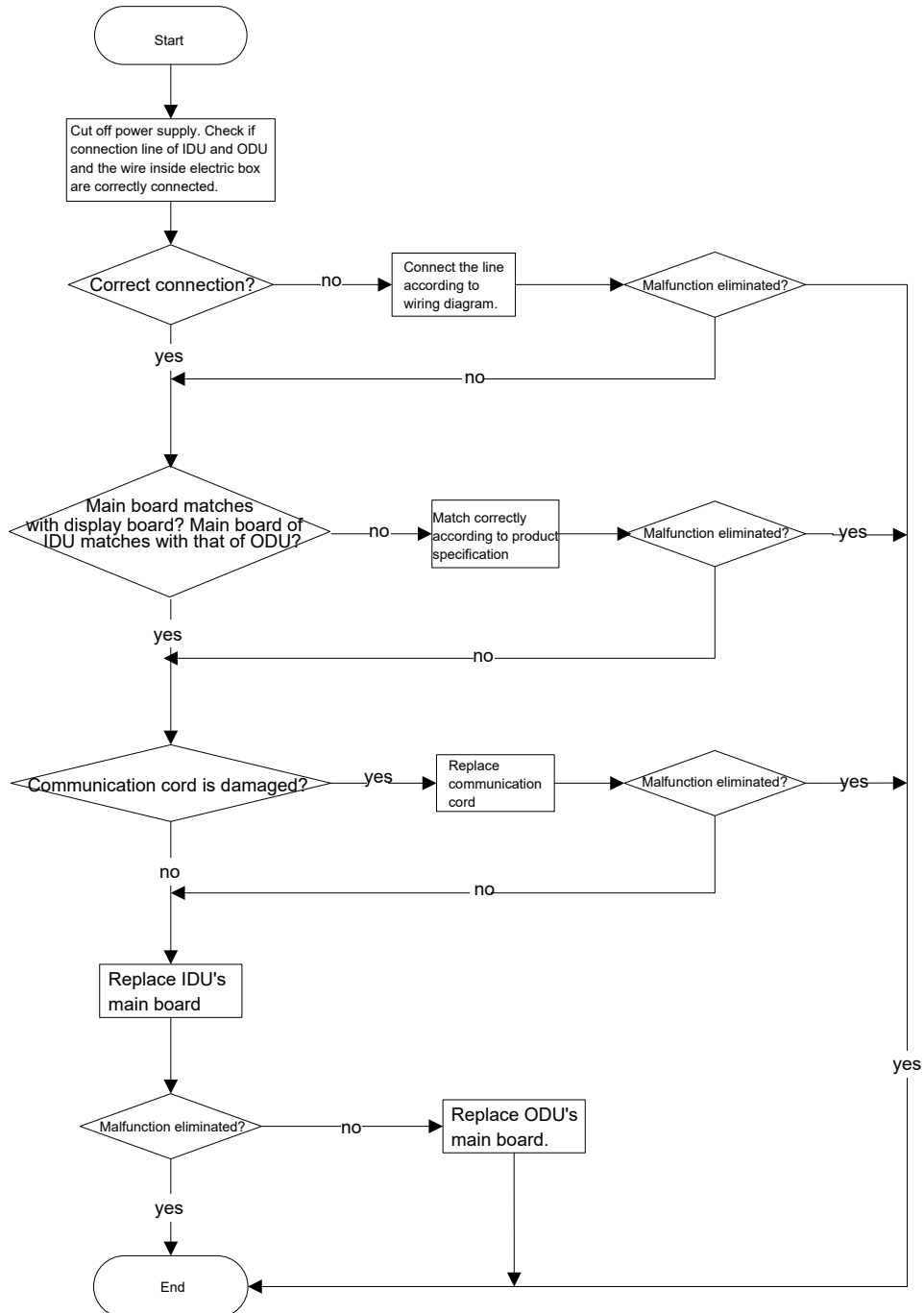



# TROUBLESHOOTING

## Malfunction of Power Supply from Indoor to Outdoor Unit

Inspect the power supply plug seat with hAC voltage gauge to check if voltage between L and N is within 200VAC-240 VAC.  
Check with AC voltage gauge if the voltage between N1 and 3 of indoor wiring block is within 200 VAC-240VAC

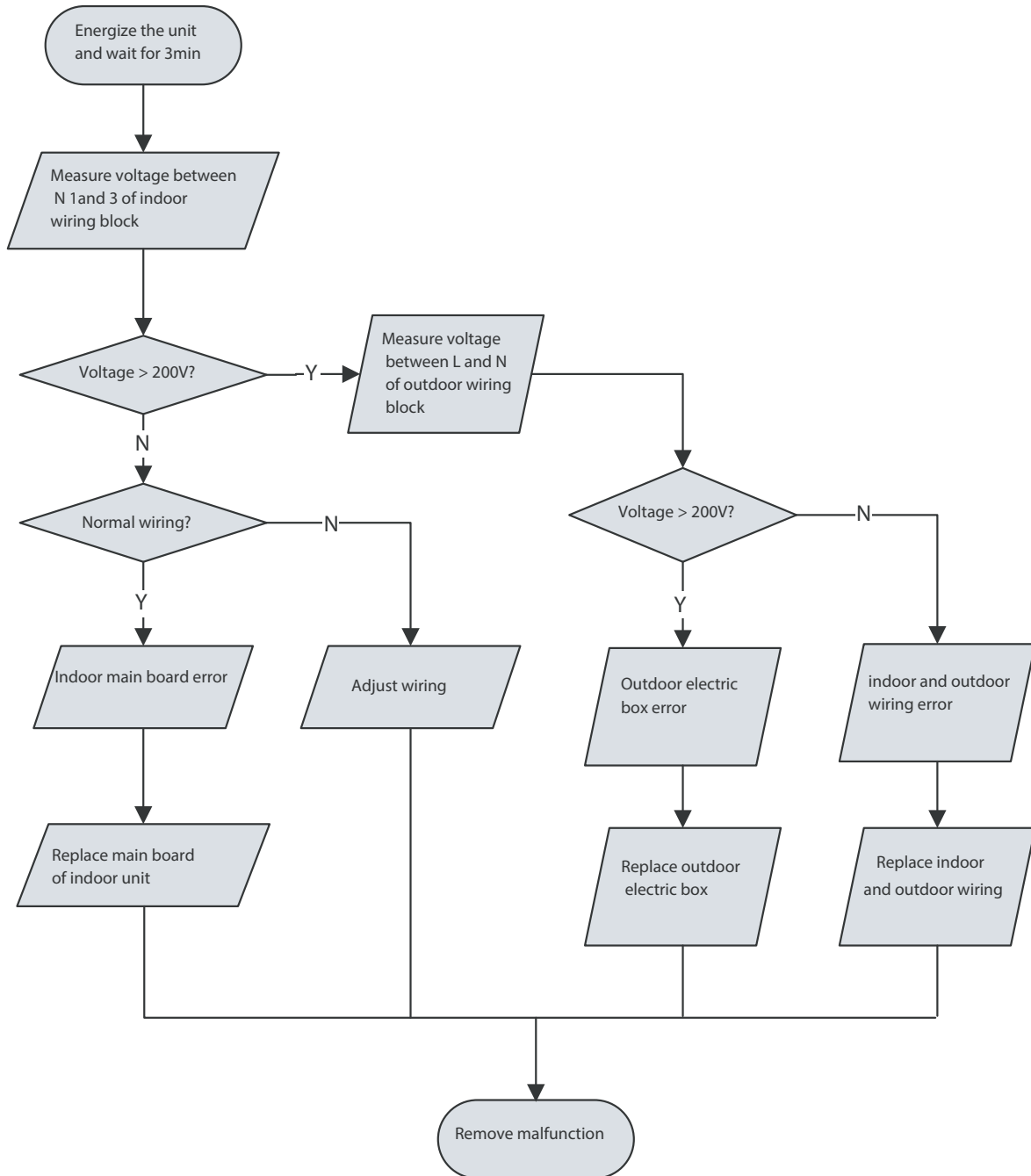

---

# TROUBLESHOOTING

## Malfunction of Detecting Plate (WIFI) JF

### Malfunction of detecting plate(WIFI) JF

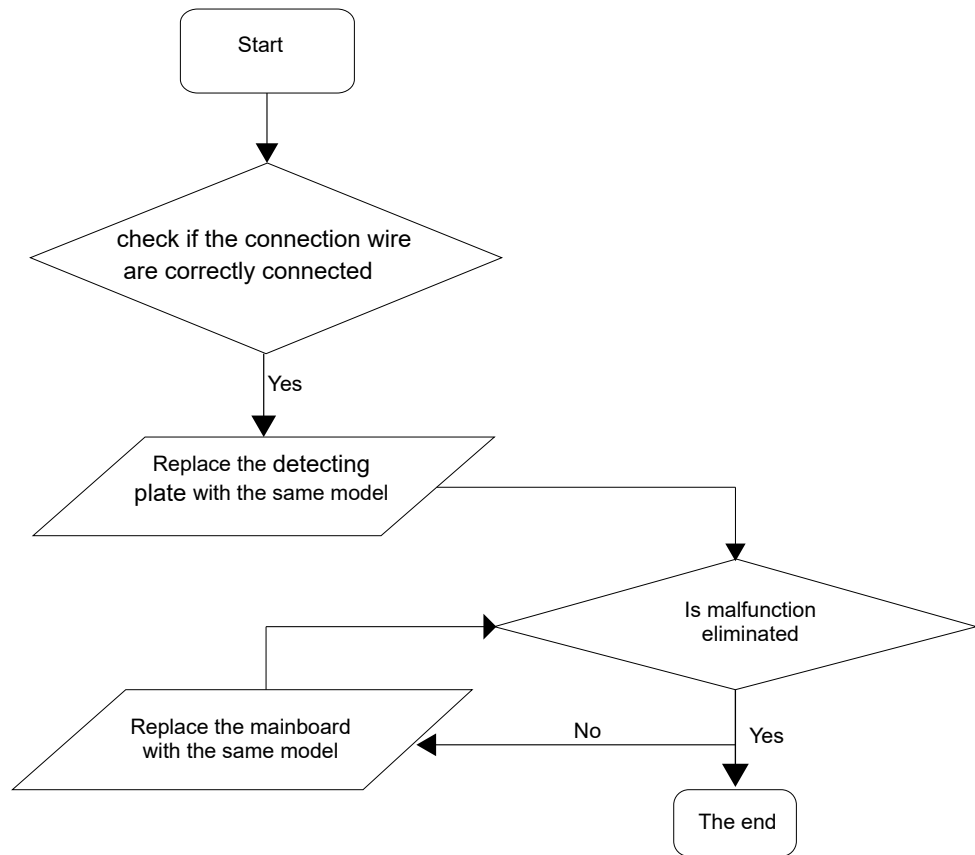

# TROUBLESHOOTING

## Indoor fan does not rotate and there is no Feedback

Is the control panel reliably connected with the motor? Is it loose? Is the connecting sequence correct?

Is the input voltage within the normal range (measure the voltage between L and N of the wiring block XT with AC voltage gauge.)?

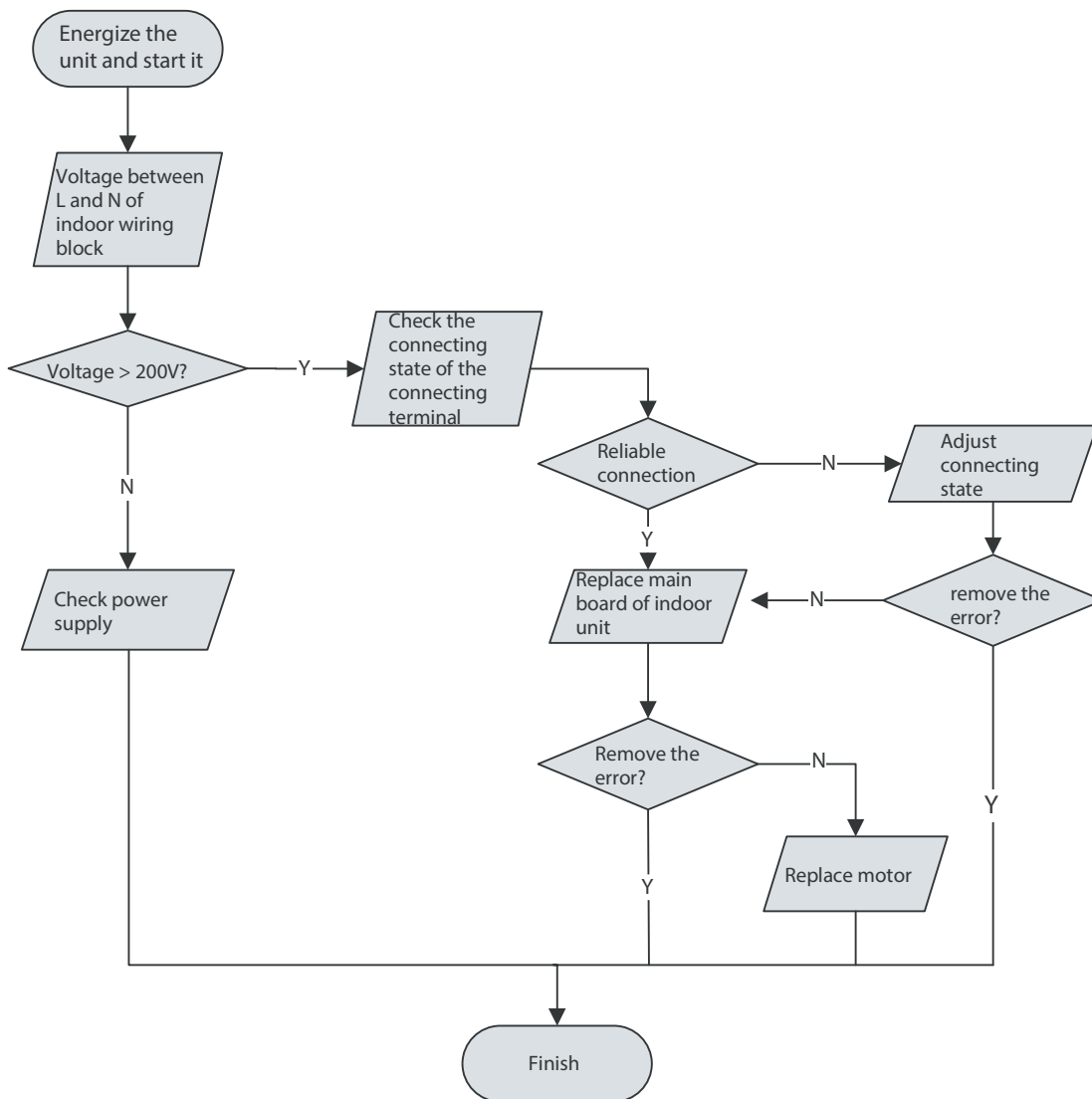

# TROUBLESHOOTING

## Temperature sensor malfunction

Is outdoor ambient temperature within the normal range?

Is indoor and outdoor fan running normally?

Is the radiating environment inside and outside the unit good enough?

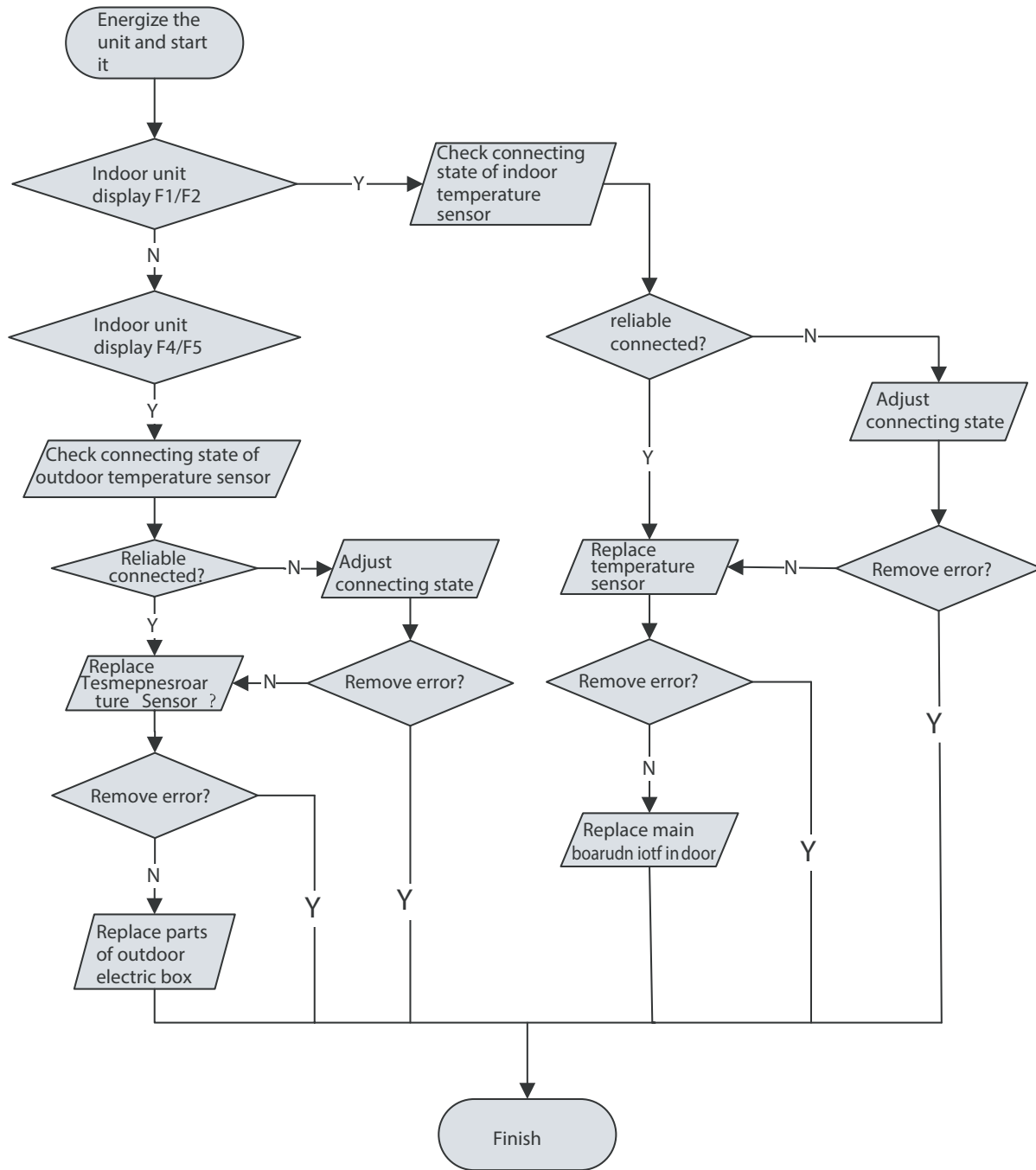

# TROUBLESHOOTING

## Malfunction diagnosis of startup failure

Is wiring of compressor correct.

Is the stop time of compressor enough?

Is compressor damaged?

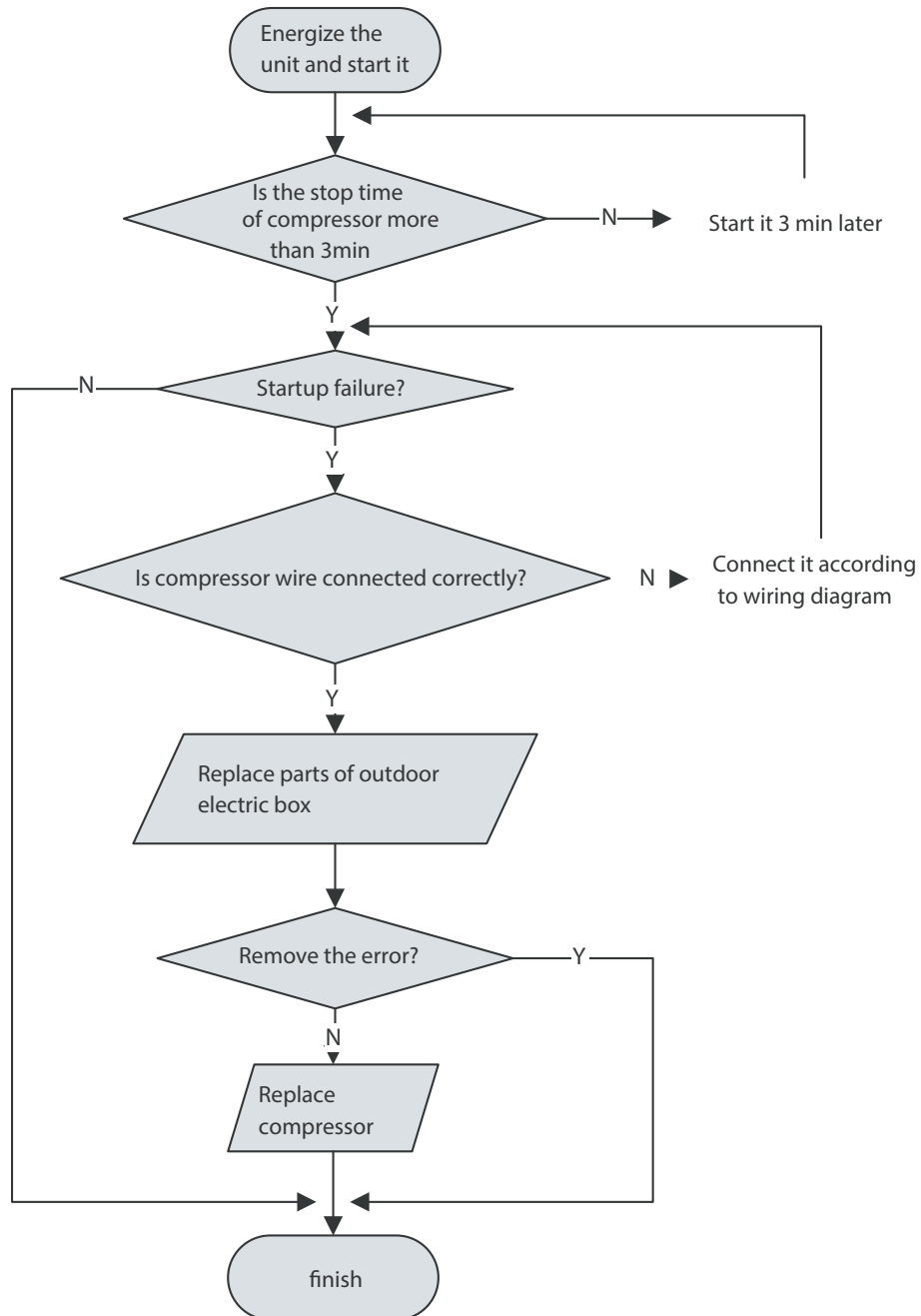

# TROUBLESHOOTING

## Diagnosis of losing synchronism for compressor

(AP1 below is control board of outdoor unit)

- If the system pressure is over-high?
- If the work voltage is over-low?

Malfunction diagnosis process:

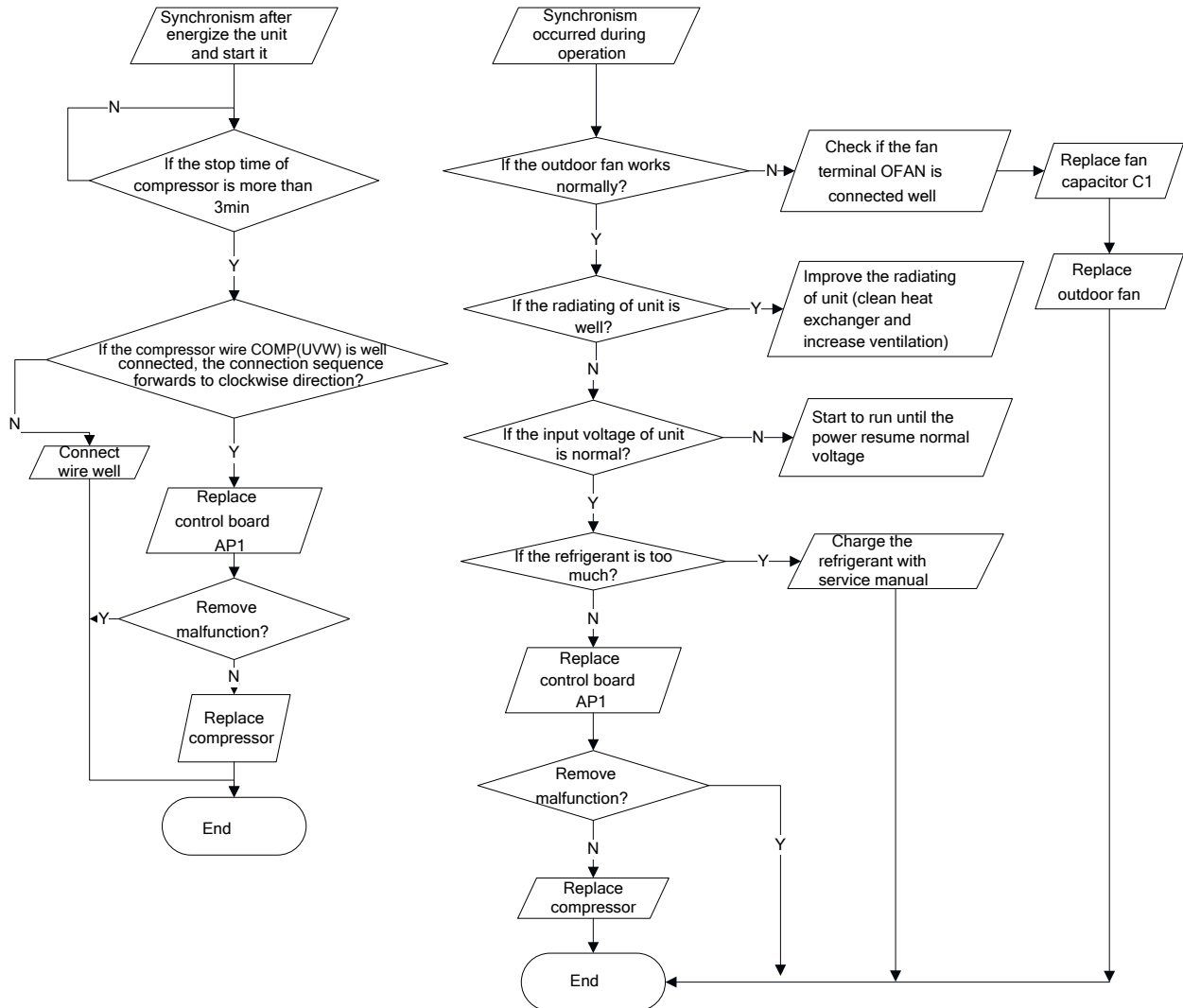

# TROUBLESHOOTING

## 9-12k, 36k Diagnosis of overload and discharge malfunction

Is electric expansion valve well connected? Is it damaged?

Is refrigerant leaked?

Is overload wire connection normal?

Are resistances between the first four pins close to the terminal hole and the 5th pin almost the same.? They should be less than 100 ohm.

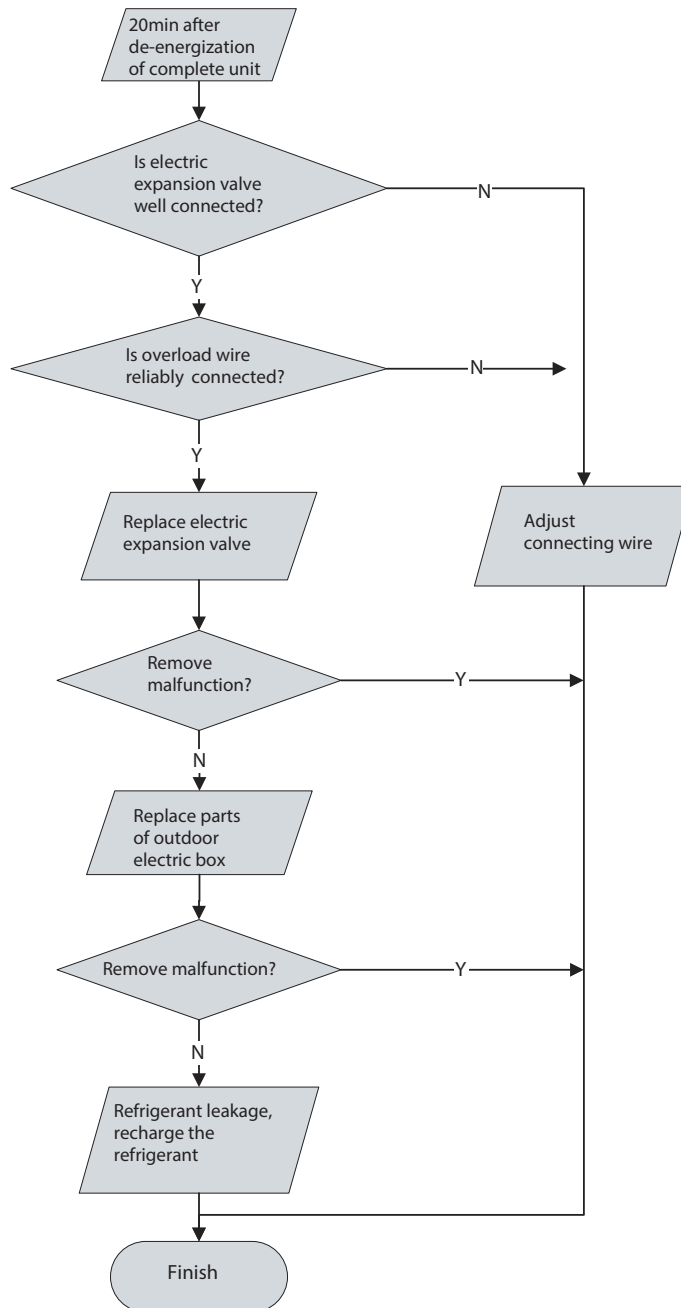

# TROUBLESHOOTING

## 18-24k Diagnosis of overload and discharge malfunction

Diagnosis for overload and discharge malfunction (AP1 below is control board of outdoor unit)

Main detection point:

- If the electron expansion valve is connected well? Is the expansion valve damaged?
- If the refrigerant is leakage?
- If the overload protector is damaged?

Malfunction diagnosis process:

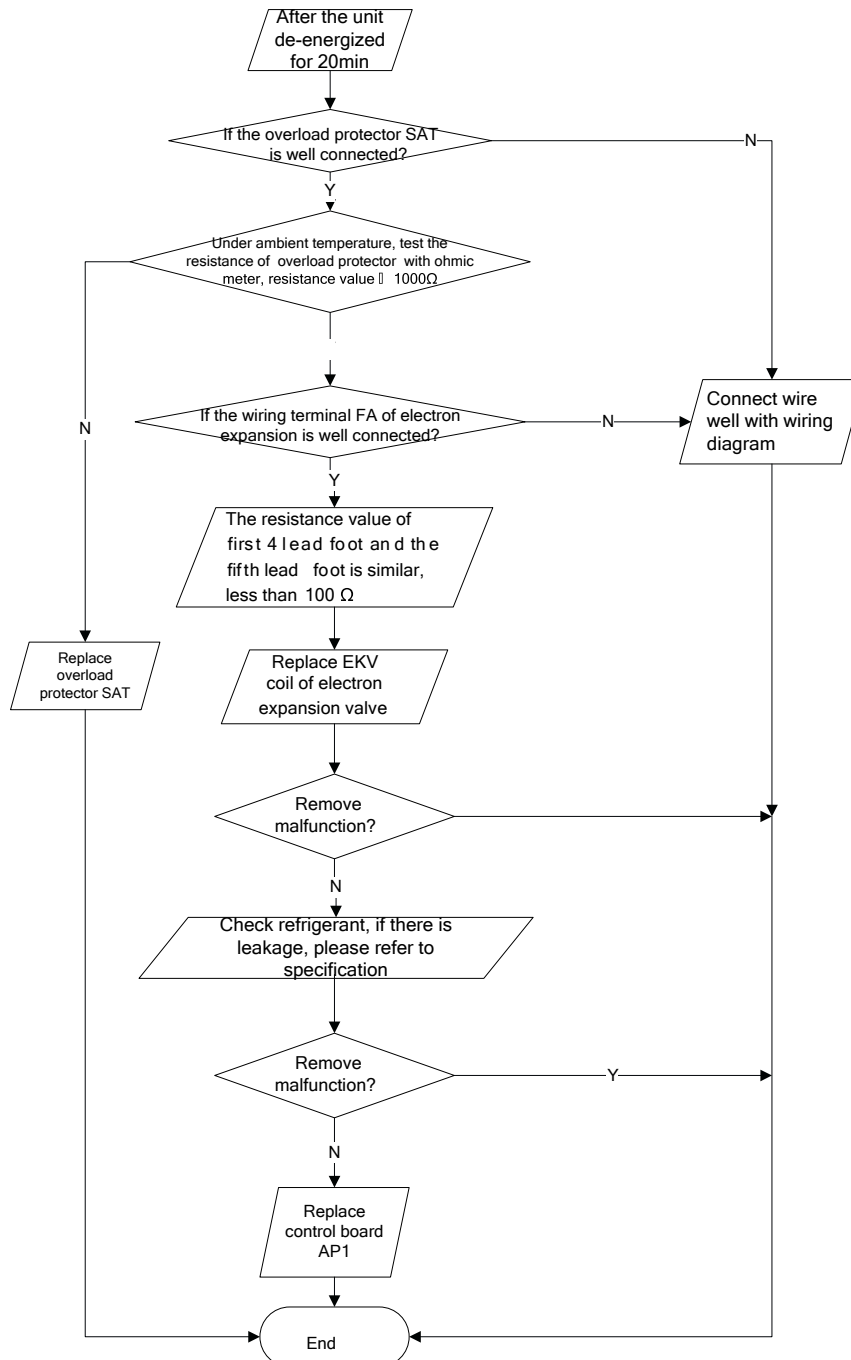



# TROUBLESHOOTING

## Capacity Charging malfunction - Outdoor unit

1) Capacitor charge fault (Fault with outdoor unit) (AP1 below refers to the outdoor control panel)

Main Check Points:

Use AC voltmeter to check if the voltage between terminal L and N on the wiring board is within 210VAC~240VAC.  
If the reactor (L) is correctly connected? If the connection is loose or fallen? If the reactor (L) is damaged?

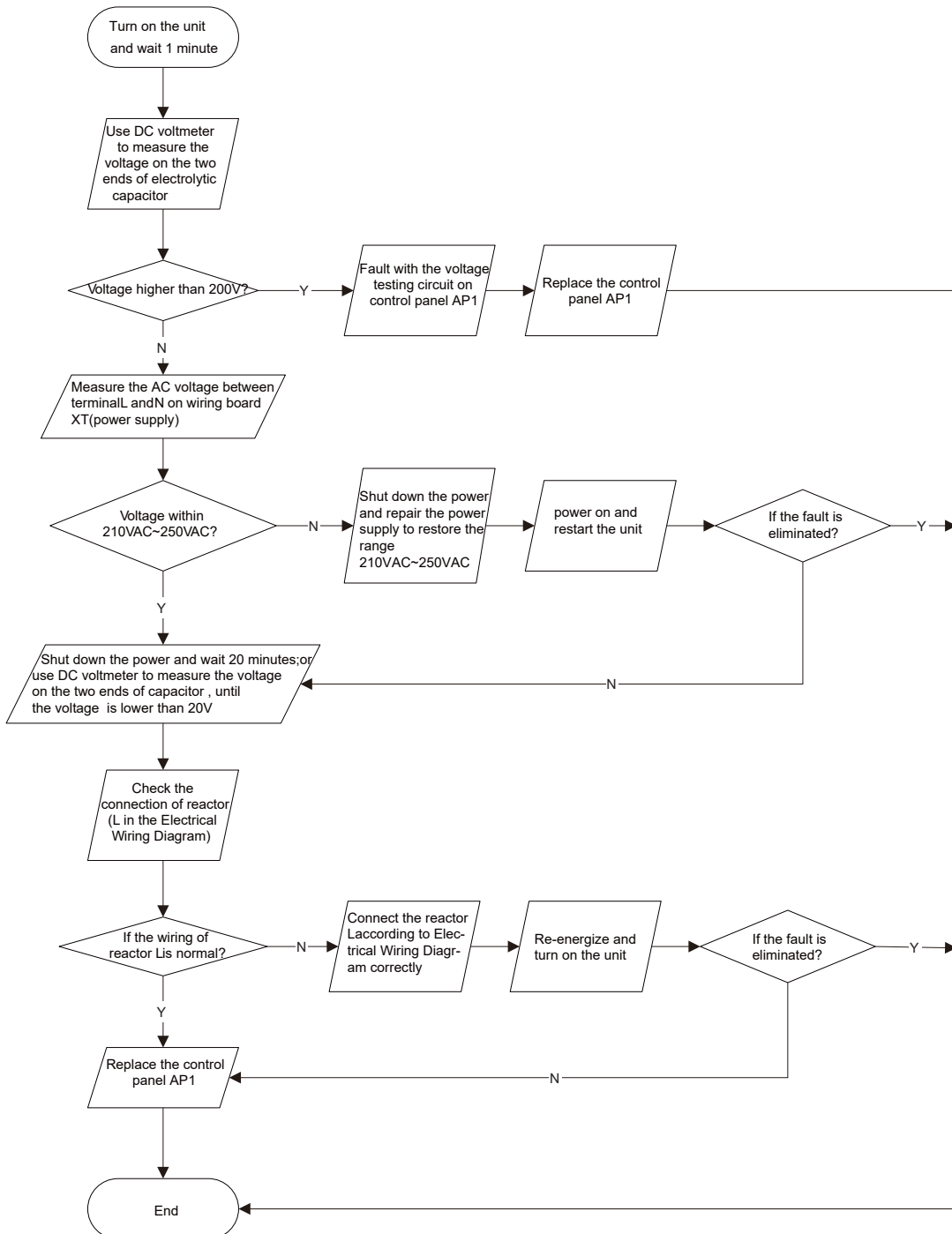

# TROUBLESHOOTING

## 9-24k PM protection, phase current overcurrent

(the control board as below indicates the control board of outdoor unit) H5/P5

Mainly detect:

- (1) Compressor COMP terminal
- (2) voltage of power supply
- (3) compressor
- (4) Refrigerant-charging volume
- (5) air outlet and air inlet of outdoor/indoor unit

Troubleshooting:

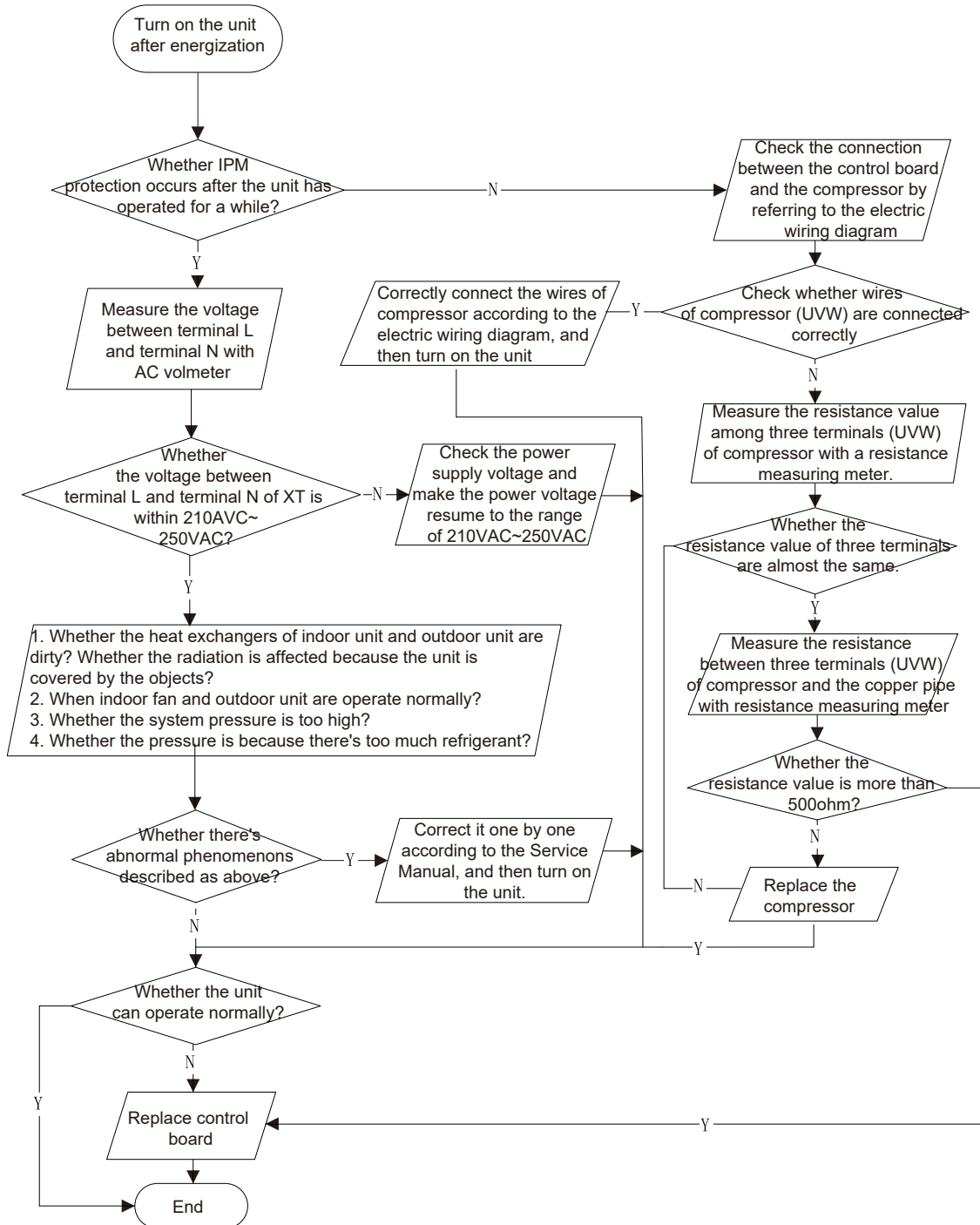

# TROUBLESHOOTING

## 36k IPM Protection, Out-of-Step Fault, Compressor Phase Overcurrent

If the connection between control panel AP1 and compressor COMP is secure? If loose? If the connection is in correct order?

If the voltage input of the machine is within normal range? (Use AC voltmeter to measure the voltage between terminal L and N on the wiring board XT)

If the compressor coil resistance is normal? If the insulation of compressor coil against the copper tube is in good condition? If the working load of the machine are too high? If the radiation is good?

If the charge volume of refrigerant is correct?

(AP1 below refers to the outdoor control panel)

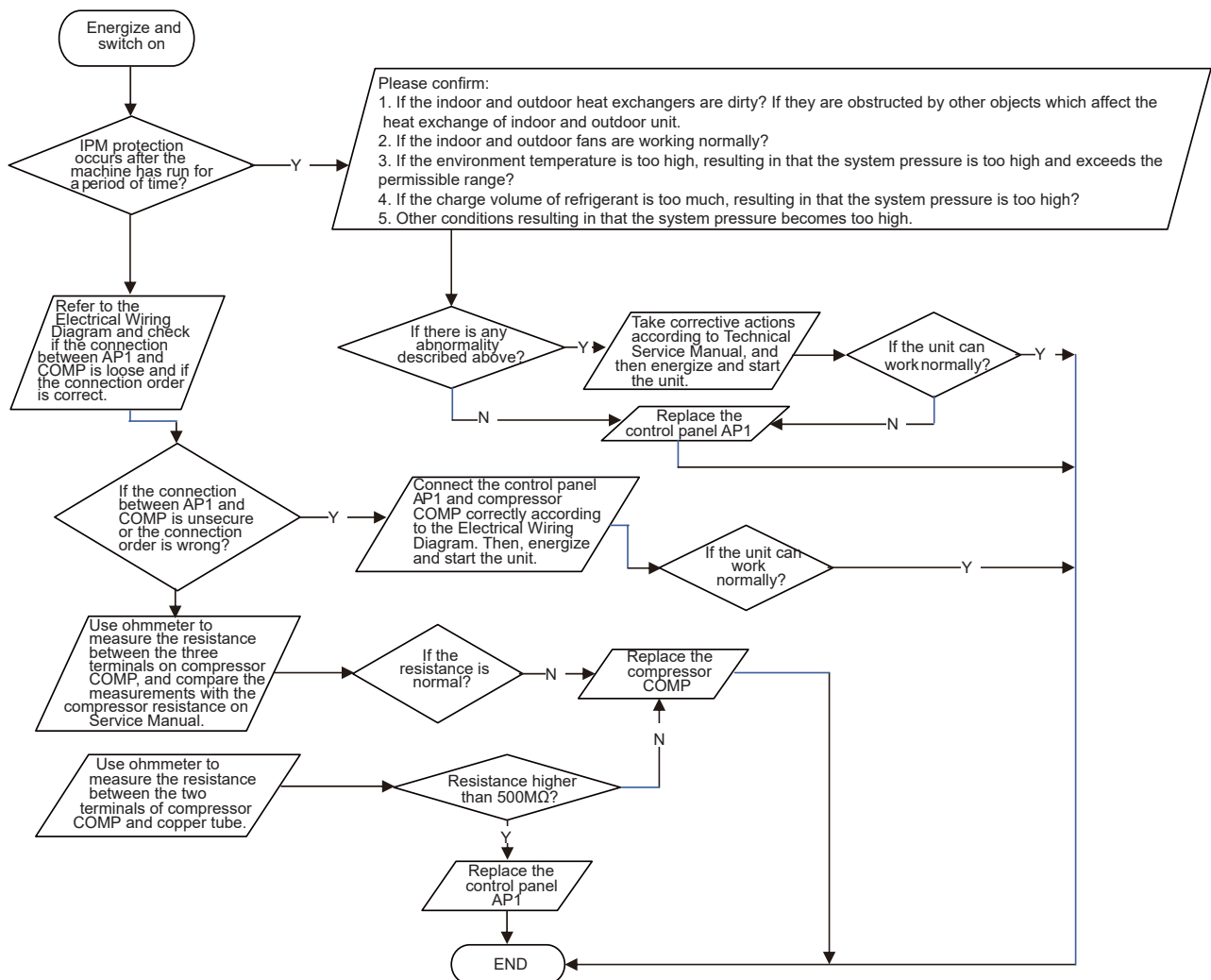

# TROUBLESHOOTING

## High temperature and Overload Protection Diagnosis

Is outdoor ambient temperature in normal range?  
Are the outdoor and indoor fans operating normally?  
Is the heat dissipation environment inside and outside the unit is good?  
(AP1 below refers to the outdoor control panel)

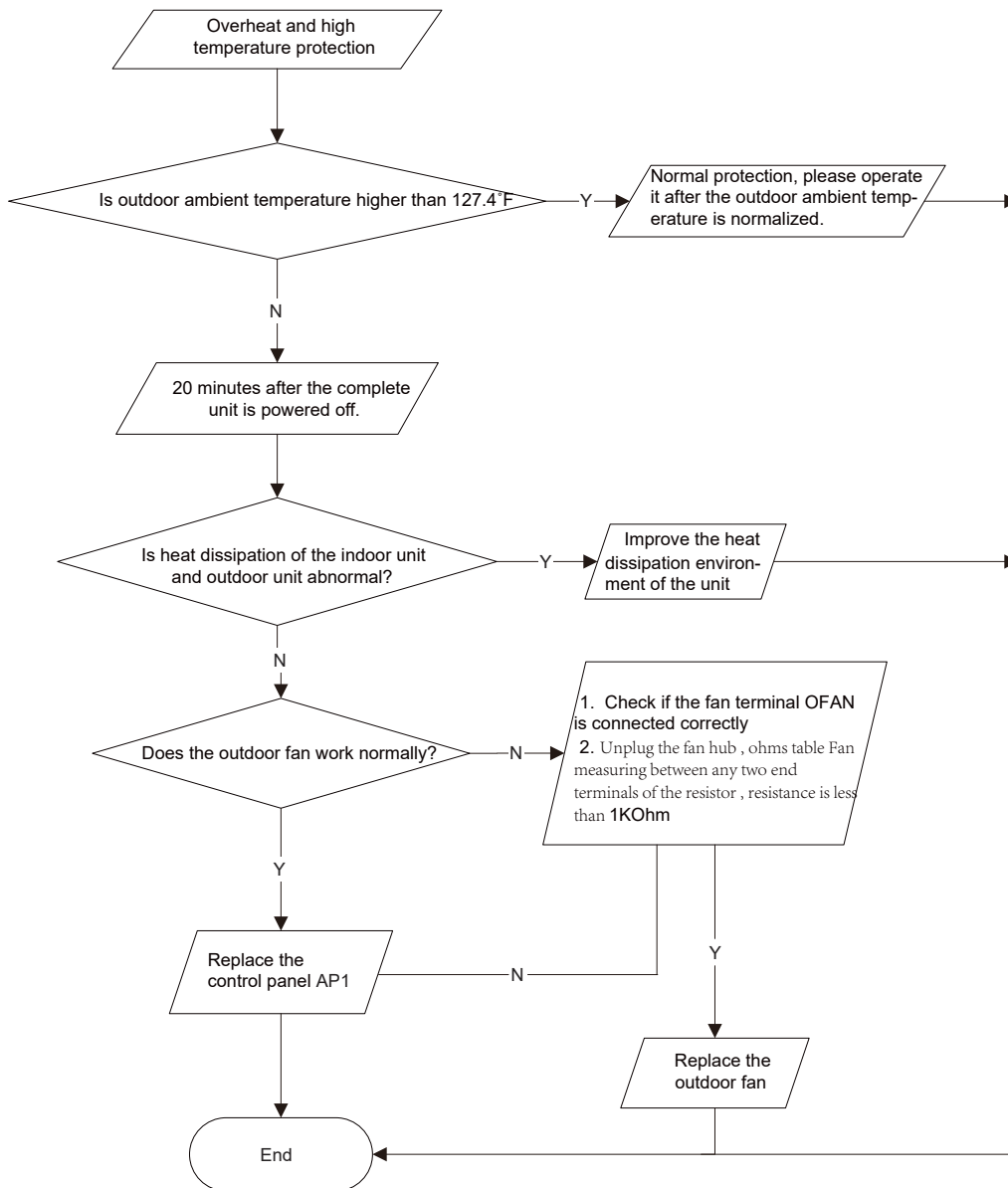

# TROUBLESHOOTING

## PFC (Correction Power Factor) Outdoor Unit Malfunction

AP1 hereinafter refers to the control board of the outdoor unit

Check if the reactor (L) of the outdoor unit and the PFC capacitor are broken

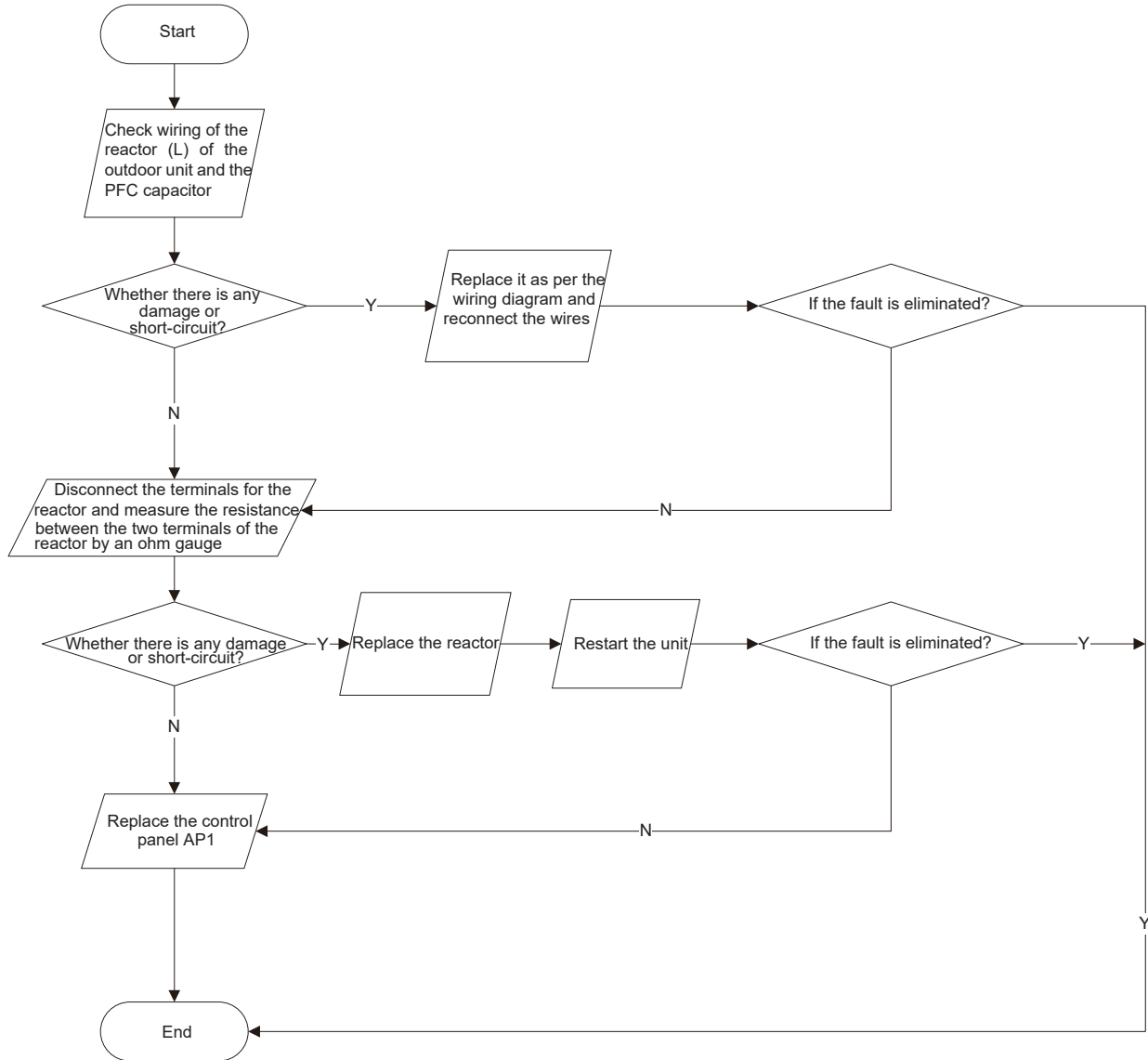

# TROUBLESHOOTING

## Communication malfunction: (following AP1 for outdoor unit control board)

(8) Communication malfunction: (following AP1 for outdoor unit control board)

Mainly detect:

- Is there any damage for the indoor unit mainboard communication circuit? Is communication circuit damaged?
- Detect the indoor and outdoor units connection wire and indoor and outdoor units inside wiring is connect well or not, if is there any damage?

Fault diagnosis process:

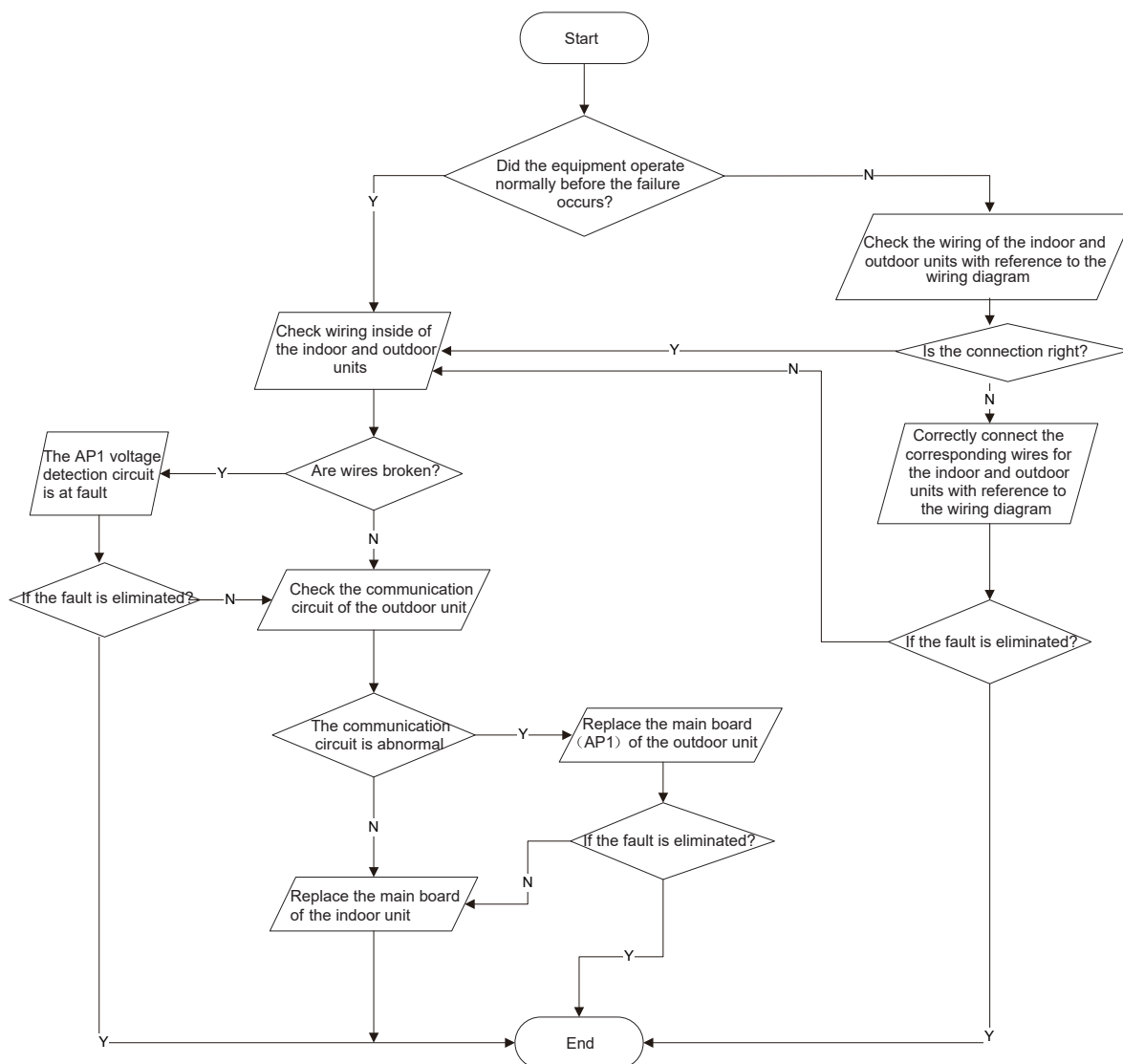

# TROUBLESHOOTING

## High-pressure Protection

### High-pressure Protection

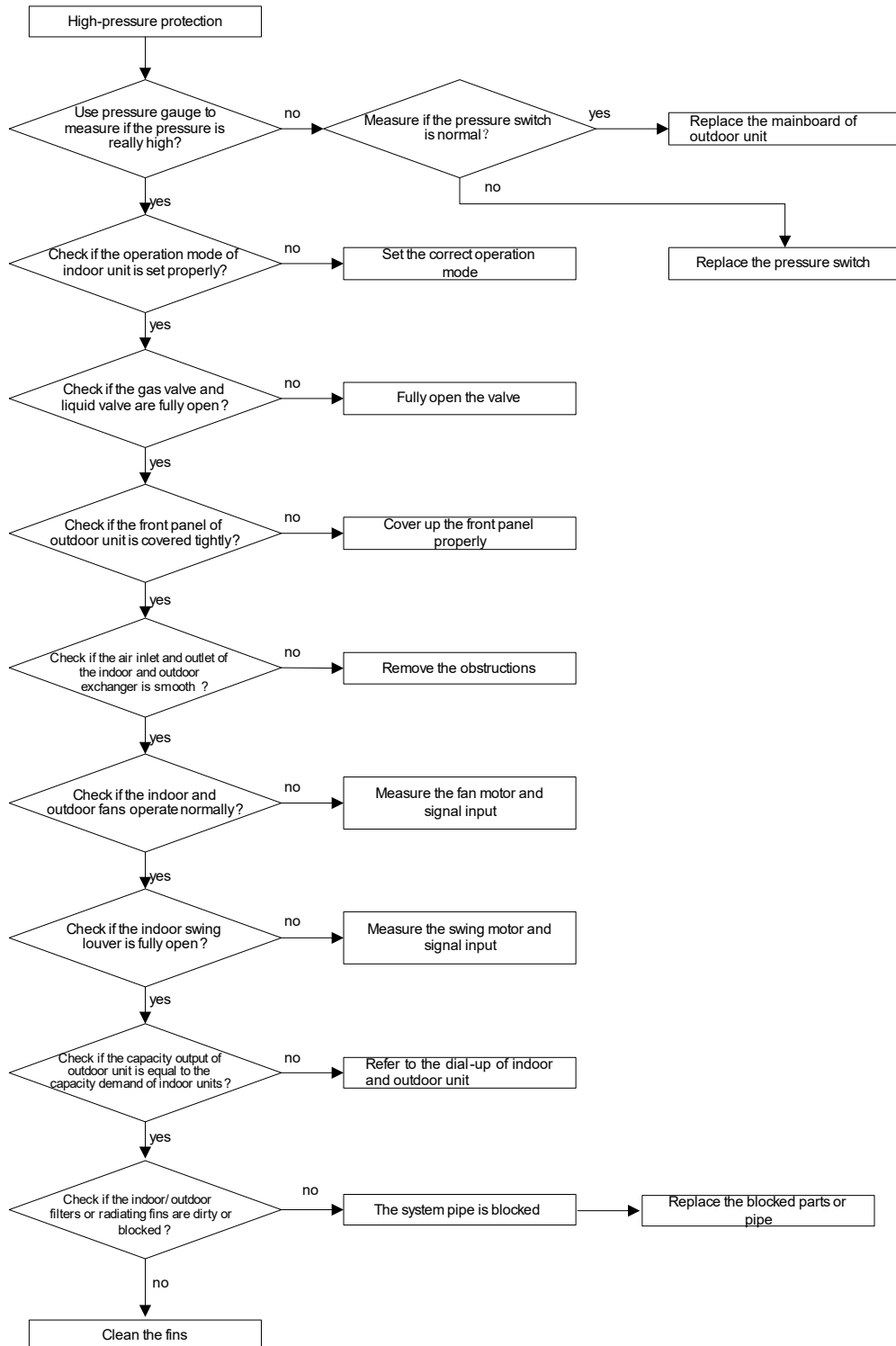

# TROUBLESHOOTING

## Troubleshooting for Malfunction without Active Error Code

| Possible Causes   | Discriminating Method (Air conditioner Status)  | Troubleshooting  |
|---|---|--|
| Air Conditioner will not start up   |   |  |
| No power supply, or poor connection for power plug  | After energization, operation indicator isn't bright and the buzzer can't give out sound  | Confirm whether it's due to power failure. If yes, wait for power recovery. If not, check power supply circuit and make sure the power plug is connected well.   |
| "Wrong wire connection between indoor unit and outdoor unit, or poor connection for wiring terminals" | Under normal power supply circumstances, operation indicator isn't bright after energization  | Check the circuit according to circuit diagram and connect wires correctly. Make sure all wiring terminals are connected firmly  |
| Electric leakage for air conditioner  | After energization, room circuit breaker trips off at once  | "Make sure the air conditioner is grounded reliably<br>Make sure wires of air conditioner is connected correctly<br>Check the wiring inside air conditioner. Check whether the insulation layer of power cord is damaged; if yes, place the power cord." |
| Model selection for air switch is improper  | After energization, air switch trips off  | Select proper air switch   |
| Malfunction of remote controller  | After energization, operation indicator is bright, while no display on remote controller or buttons have no action.   | Replace batteries for remote controller Repair or replace remote controller  |
| Poor Cooling (Heating) for Air Conditioner  |   |  |
| Set temperature is improper   | Observe the set temperature on remote controller  | Adjust the set temperature   |
| Rotation speed of the IDU fan motor is set too low  | Small wind blow   | Set the fan speed at high or medium  |
| Filter of indoor unit is blocked  | Check the filter to see it's blocked  | Clean the filter   |
| Installation position for indoor unit and outdoor unit is improper                                    | Check whether the installation position is proper according to installation requirement for air conditioner   | Adjust the installation position, and install the rainproof and sunproof for outdoor unit  |
| Refrigerant is leaking  | Discharged air temperature during cooling is higher than normal discharged wind temperature; Discharged air temperature during heating is lower than normal discharged wind temperature; Unit's pressure is much lower than regulated range   | Find out the leakage causes and deal with it. Add refrigerant.   |
| Malfunction of 4-way valve  | Blow cold wind during heating   | Replace the 4-way valve  |
| Malfunction of capillary  | Discharged air temperature during cooling is higher than normal discharged wind temperature; Discharged air temperature during heating is lower than normal discharged wind temperature; Unit's pressure is much lower than regulated range. If refrigerant isn't leaking, part of capillary is blocked | Replace the capillary  |
| Flow volume of valve is insufficient  | The pressure of valves is much lower than that stated in the specification  | Open the valve completely  |
| Malfunction of horizontal louver  | Horizontal louver can't swing   | Refer to point 3 of maintenance method for details   |



# TROUBLESHOOTING

## Troubleshooting for Malfunction without Active Error Code

| Possible Causes                           | Discriminating Method (Air conditioner Status)  | Troubleshooting  |
|---|---|--|
| Malfunction of the IDU fan motor          | The IDU fan motor can't operate   | Refer to troubleshooting for H6 for maintenance method in details                                  |
| Malfunction of the ODU fan motor          | The ODU fan motor can't operate   | Refer to point 4 of maintenance method for details   |
| Malfunction of compressor                 | Compressor can't operate  | Refer to point 5 of maintenance method for details   |
| Horizontal Louver Will Not Swing          |   |  |
| Wrong wire connection, or poor connection | Check the wiring status according to circuit diagram  | Connect wires according to wiring diagram to make sure all wiring terminals are connected firmly   |
| Stepping motor is damaged                 | Stepping motor can't operate  | Repair or replace stepping motor   |
| Main board is damaged                     | Others are all normal, while horizontal louver can't operate  | Replace the main board with the same model   |
| ODU Fan Moto Can't Operate                |   |  |
| Wrong wire connection, or poor connection | Check the wiring status according to circuit diagram  | "Connect wires according to wiring diagram to make sure all wiring terminals are connected firmly" |
| Capacity of the ODU fan motor is damaged  | "Measure the capacity of fan capacitor with an universal meter and find that the capacity is out of the deviation range indicated on the nameplate of fan capacitor." | Replace the capacity of fan  |
| "Power voltage is a little low or high"   | "Use universal meter to measure the power supply voltage. The voltage is a little high or low"  | Suggest to equip with voltage regulator  |
| Motor of outdoor unit is damaged          | "When unit is on, cooling/heating performance is bad and ODU compressor generates a lot of noise and heat."   | Change compressor oil and refrigerant. If no better, replace the compressor with a new one         |
| Compressor Can't operate                  |   |  |
| Wrong wire connection, or poor connection | Check the wiring status according to circuit diagram  | "Connect wires according to wiring diagram to make sure all wiring terminals are connected firmly" |
| Capacity of compressor is damaged         | "Measure the capacity of fan capacitor with an universal meter and find that the capacity is out of the deviation range indicated on the nameplate of fan capacitor." | Replace the compressor capacitor   |
| "Power voltage is a little low or high"   | "Use universal meter to measure the power supply voltage. The voltage is a little high or low"  | Suggest to equip with voltage regulator  |
| Coil of compressor is burnt out           | "Use universal meter to measure the resistance between compressor terminals and it's 0"   | Repair or replace compressor   |

# TROUBLESHOOTING

## Troubleshooting for Malfunction without Active Error Code

| Possible Causes   | Discriminating Method (Air conditioner Status)                     | Troubleshooting  |
|---|--|--|
| Cylinder of compressor is blocked   | Compressor can't operate   | Repair or replace compressor   |
| Air Conditioner is Leaking  |  |  |
| Drain pipe is blocked   | Water leaking from indoor unit                                     | "Eliminate the foreign objects inside the drain pipe"  |
| Drain pipe is broken  | Water leaking from drain pipe                                      | Replace drain pipe   |
| Wrapping is not tight   | "Water leaking from the pipe connection place of indoor unit"      | Wrap it again and bundle it tightly  |
| Abnormal Sound and vibration  |  |  |
| "When turn on or turn off the unit, the panel and other parts will expand and there's abnormal sound"         | There's the sound of "PAPA"  | Normal phenomenon. Abnormal sound will disappear after a few minutes.  |
| "When turn on or turn off the unit, there's abnormal sound due to flow of refrigerant inside air conditioner" | Water-running sound can be heard                                   | Normal phenomenon. Abnormal sound will disappear after a few minutes.  |
| "Foreign objects inside the indoor unit or there're parts touching together inside the indoor unit"           | There's abnormal sound fro indoor unit                             | "Remove foreign objects. Adjust all parts' position of indoor unit, tighten screws and stick damping plaster between connected parts"  |
| "Foreign objects inside the outdoor unit or there're parts touching together inside the outdoor unit"         | There's abnormal sound fro outdoor unit                            | "Remove foreign objects. Adjust all parts' position of outdoor unit, tighten screws and stick damping plaster between connected parts" |
| "Short circuit inside the magnetic coil"  | "During heating, the way valve has abnormal electromagnetic sound" | Replace magnetic coil  |
| Abnormal shake of compressor  | Outdoor unit gives out abnormal sound                              | "Adjust the support foot mat of compressor, tighten the bolts"   |
| Abnormal sound inside the compressor  | Abnormal sound inside the compressor                               | "If add too much refrigerant during maintenance, please reduce refrigerant properly. Replace circumstances."                           |

# WIRING DIAGRAMS

| Symbol | Symbol Color | Symbol | Symbol Color | Symbol | Name           |
|--------|--------------|--------|--------------|--------|----------------|
| WH     | White        | GN     | Green        | CAP    | Jumper cap     |
| YE     | Yellow       | BN     | Brown        | COMP   | Compressor     |
| RD     | Red          | BU     | Blue         | ⊕      | Grounding wire |
| YEGN   | Yellow/Green | BK     | Black        | /      | /              |
| VT     | Violet       | OG     | Orange       | /      | /              |

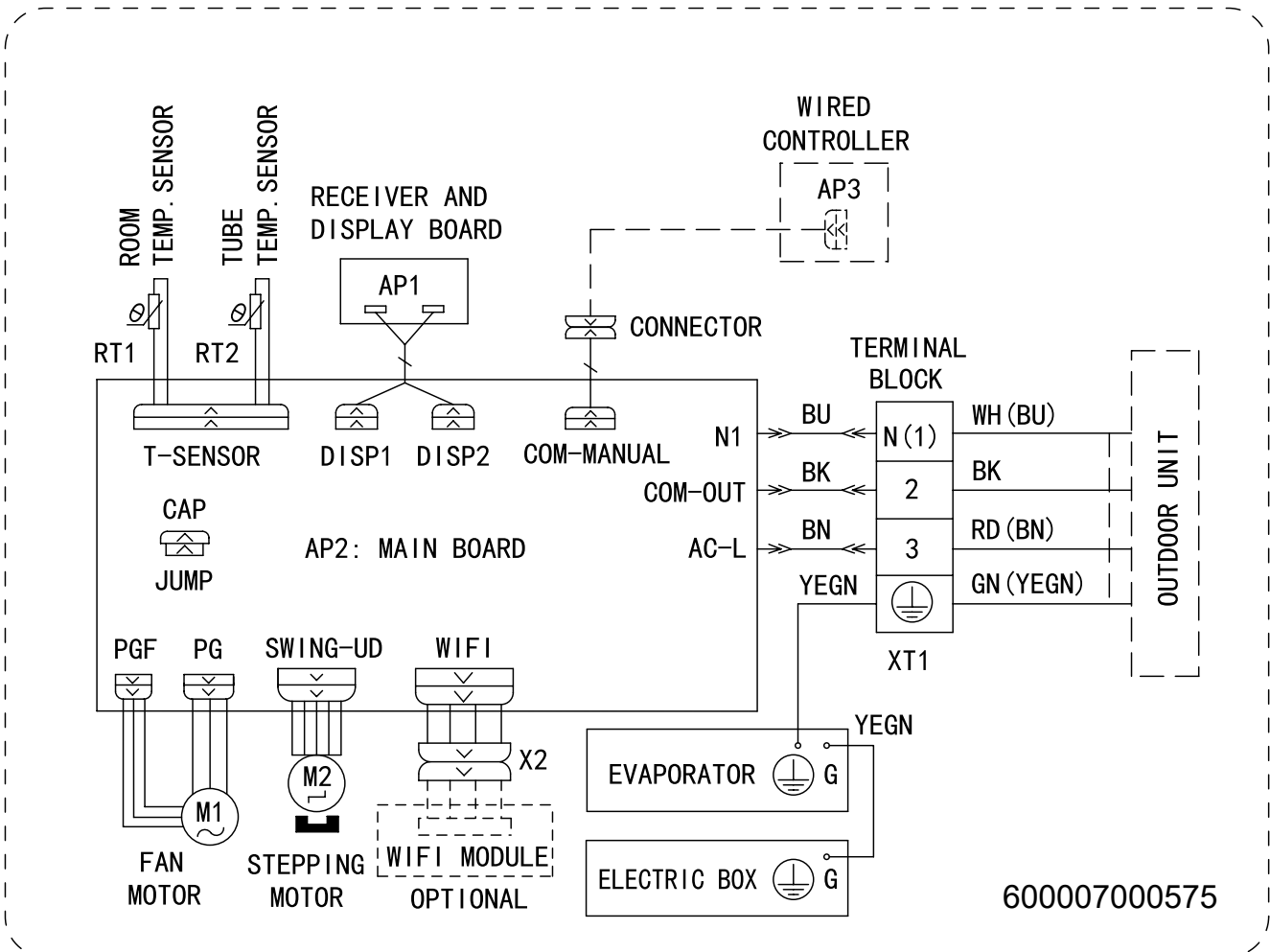

Figure 801

9-12K Indoor Unit Wiring Diagram

# WIRING DIAGRAMS

| Symbol | Symbol Color | Symbol | Symbol Color | Symbol | Name           |
|--------|--------------|--------|--------------|--------|----------------|
| WH     | White        | GN     | Green        | CAP    | Jumper cap     |
| YE     | Yellow       | BN     | Brown        | COMP   | Compressor     |
| RD     | Red          | BU     | Blue         |        | Grounding wire |
| YEGN   | Yellow/Green | BK     | Black        | /      | /              |
| VT     | Violet       | OG     | Orange       | /      | /              |

Note: Jumper cap is used to determine fan speed and the swing angle of horizontal lever for this model.

## • Indoor Unit

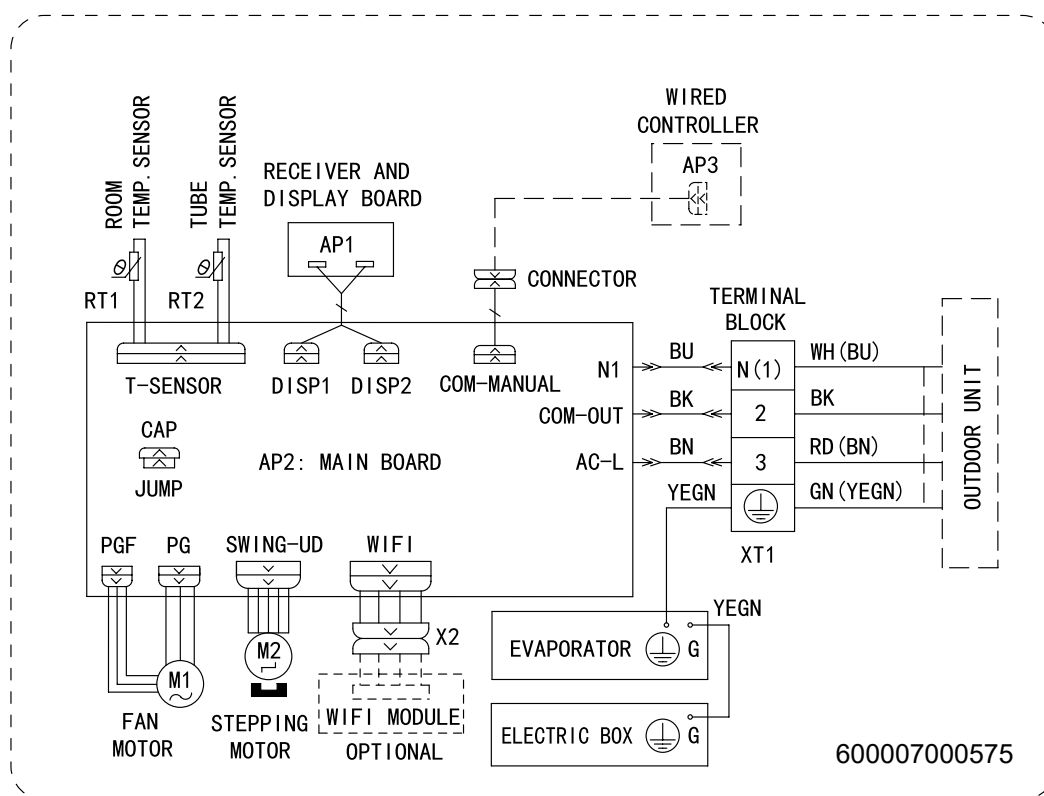

Figure 802

18-24k Indoor Unit Wiring Diagram

# WIRING DIAGRAMS

| Symbol | Symbol Color | Symbol | Symbol Color | Symbol | Name           |
|--------|--------------|--------|--------------|--------|----------------|
| WH     | White        | GN     | Green        | CAP    | Jumper cap     |
| YE     | Yellow       | BN     | Brown        | COMP   | Compressor     |
| RD     | Red          | BU     | Blue         |        | Grounding wire |
| YEGN   | Yellow/Green | BK     | Black        | /      | /              |
| VT     | Violet       | OG     | Orange       | /      | /              |

Note: Jumper cap is used to determine fan speed and the swing angle of horizontal lover for this model.

## • Indoor Unit

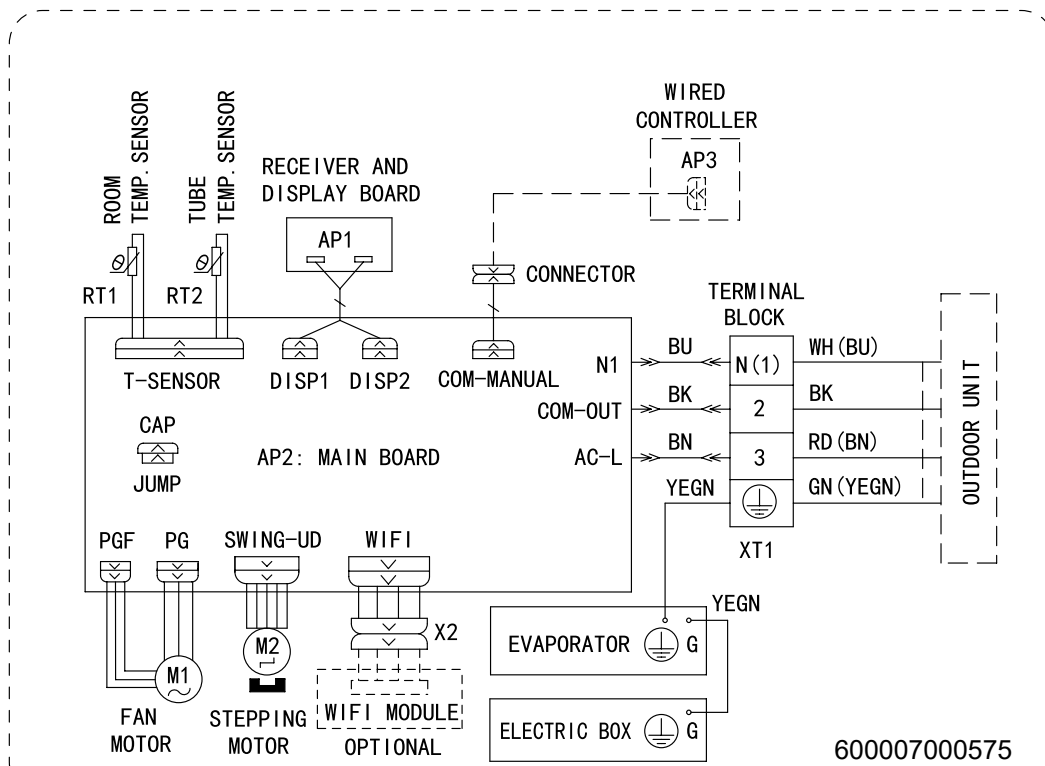

Figure 803

36K Indoor Unit Wiring Diagrams

# WIRING DIAGRAMS

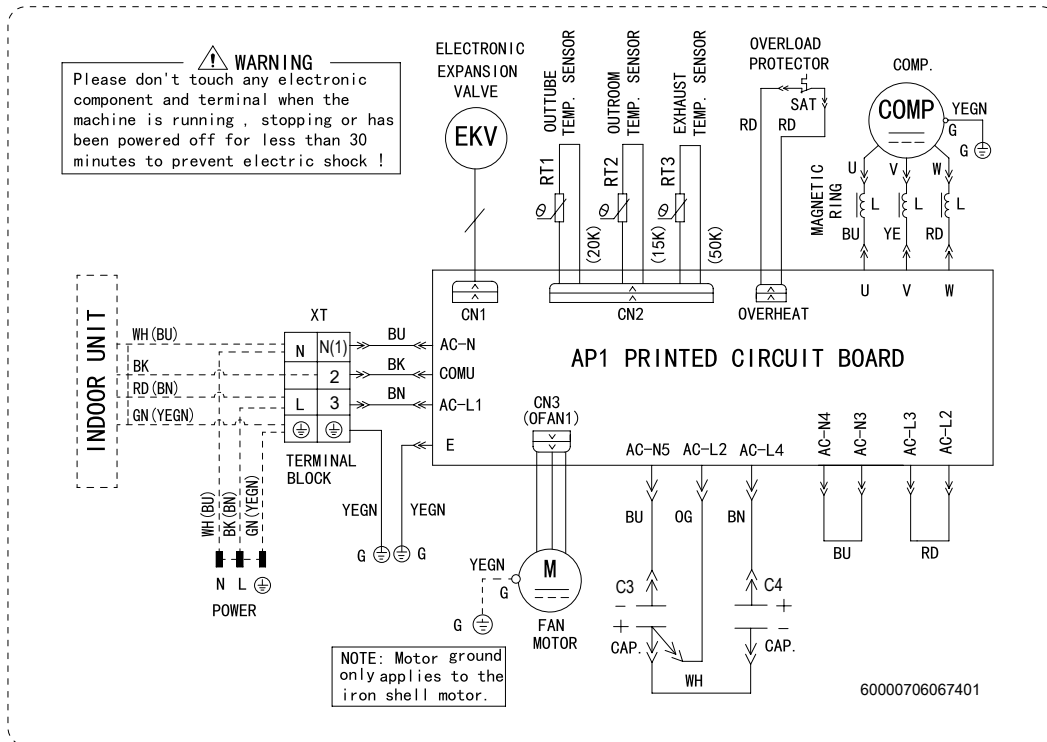
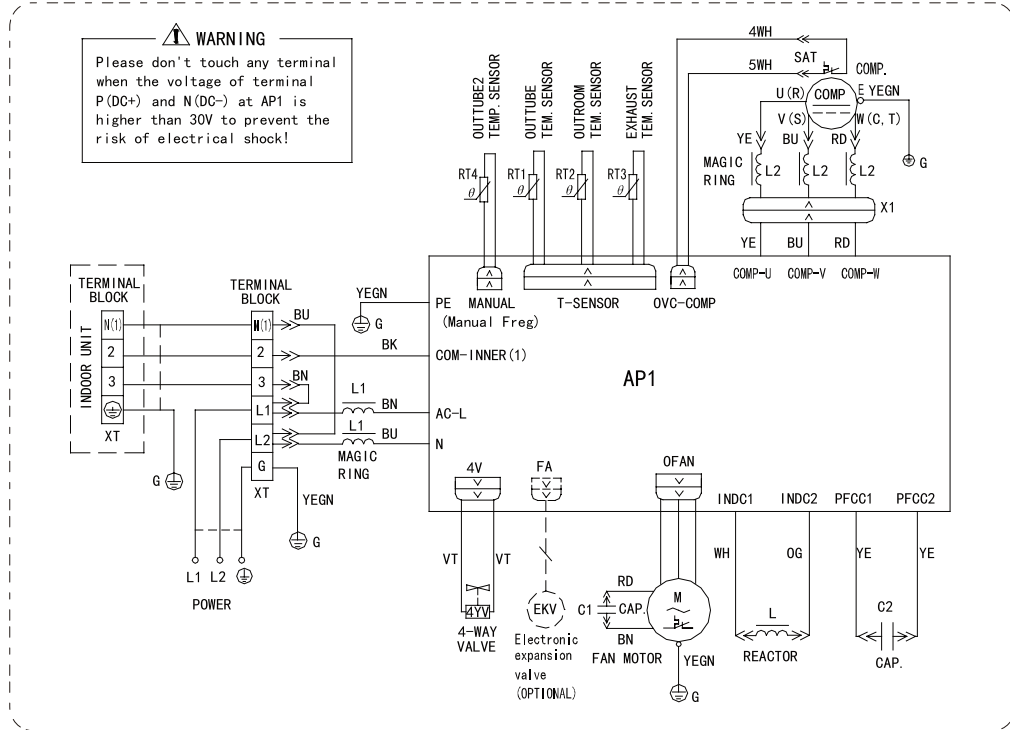
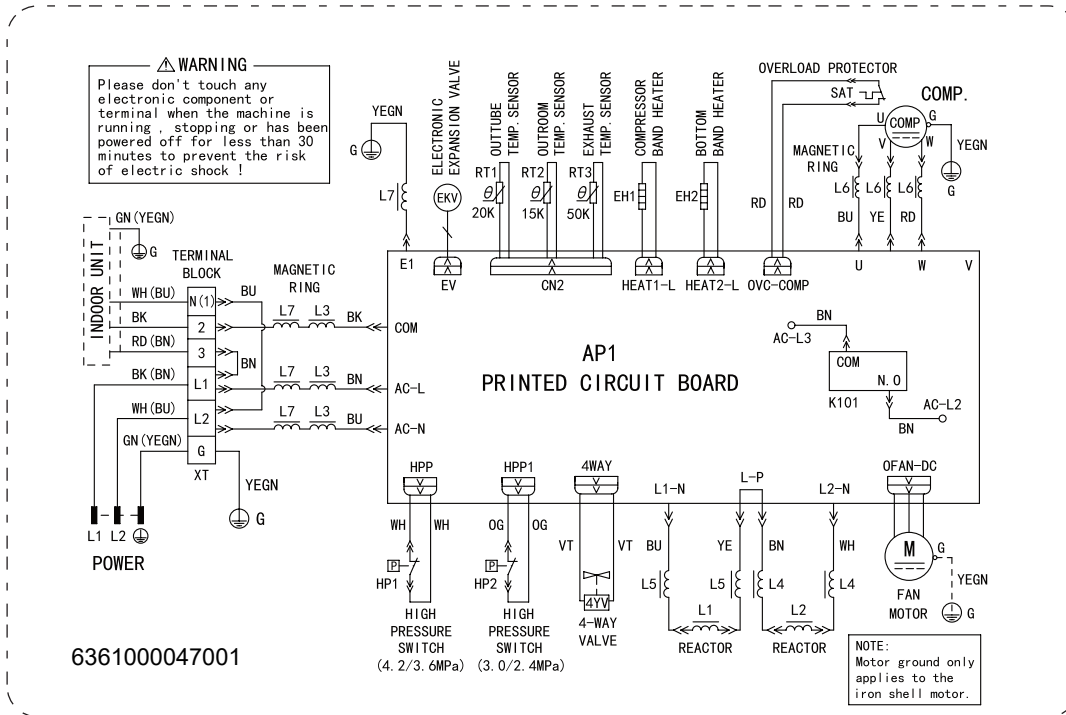

Figure 8054 9-12K Outdoor Unit Wiring Diagrams

# WIRING DIAGRAMS



## 18-24k Outdoor Unit Wiring Diagrams



## 36k Outdoor Unit Wiring Diagrams

# PARTS CATALOG

## 9K Indoor Unit

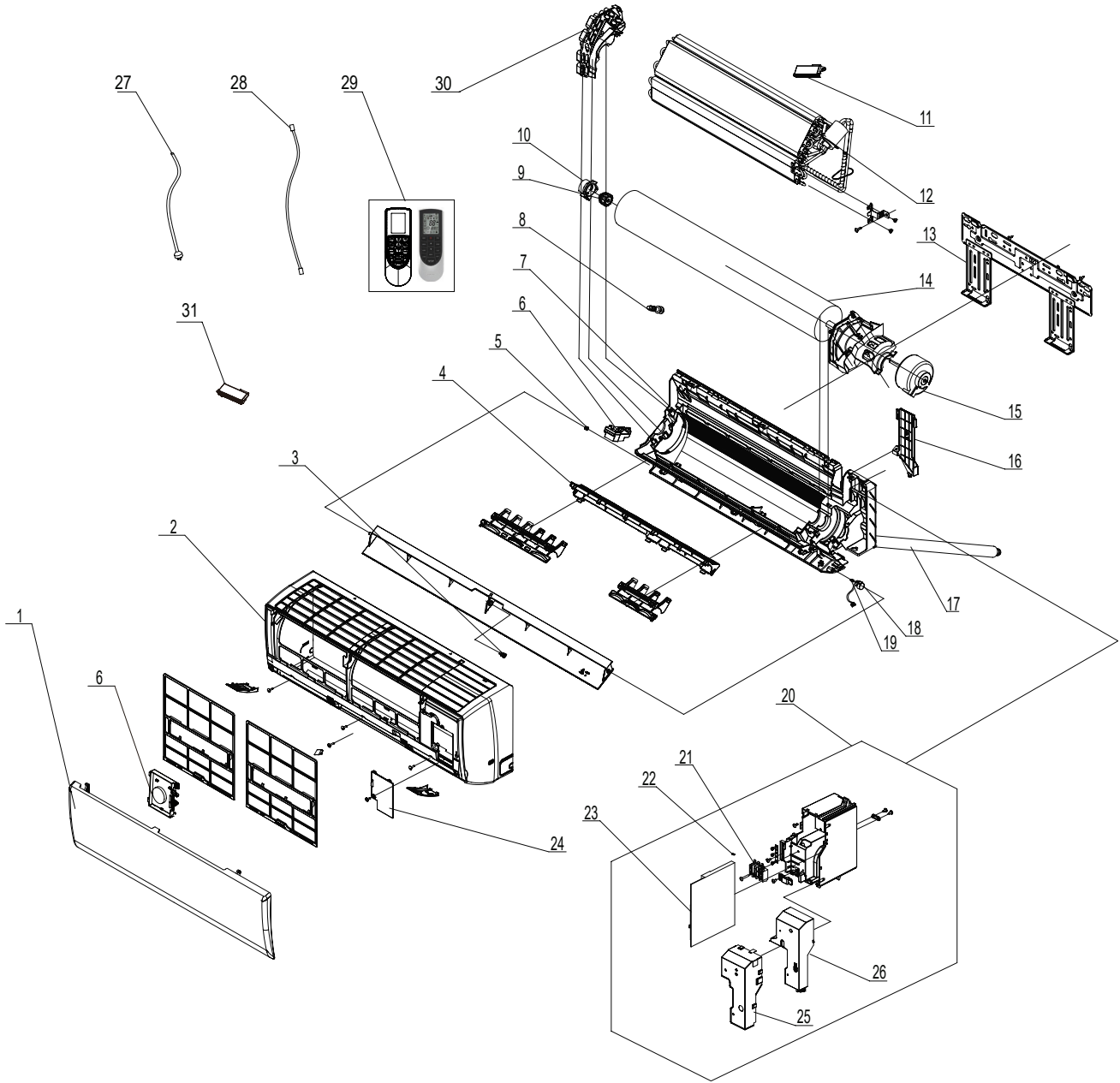

Figure 901



# PARTS CATALOG

## 9k Indoor Unit

| FIGURE 901  |             |  |               |     |
|---|-------------|--|---------------|-----|
| ITEM  | PART NUMBER | PART DESCRIPTION                             | USED ON MODEL | QTY |
| 1   | 69700627    | 300036 - Front Panel Assy                    | FSHW09A1A     | 1   |
| 2   | 69700628    | 30565260 - Display Board                     | FSHW09A1A     | 2   |
| 3   | 69700629    | 2002249501 - Front Case Assy                 | FSHW09A1A     | 1   |
| 4   | 69700630    | 26112508 - Helicoid Tongue                   | FSHW09A1A     | 1   |
| 5   | 69700631    | 10512037 - Left Axile Bush                   | FSHW09A1A     | 1   |
| 6   | 69700632    | 100066 - Rear Case assy                      | FSHW09A1A     | 1   |
| 7   | 69700633    | 523001408 - Drainage Hose                    | FSHW09A1A     | 1   |
| 8   | 69700666    | 26152022 - Ring of Bearing                   | FSHW09A1A     | 2   |
| 9   | 69700635    | 7651205102 - O-Gasket sub-assy of Bearing    | FSHW09A1A     | 2   |
| 10  | 69700636    | 24212180 - Evaporator Support                | FSHW09A1A     | 1   |
| 11  | #N/A        | #N/A   | FSHW09A1A     | 1   |
| 12  | 69700638    | 100200004407 - Evaporator Assy               | FSHW09A1A     | 1   |
| 13  | 69700639    | 1252043 - Wall Mounting Frame                | FSHW09A1A     | 1   |
| 14  | 69700640    | 10352059 - Cross Flow Fan                    | FSHW09A1A     | 1   |
| 15  | 69700641    | 1501208902 - Fan Motor                       | FSHW09A1A     | 1   |
| 16  | 69700642    | 2611216401 - Connecting pipe clamp           | FSHW09A1A     | 1   |
| 17  | 69700481    | 76712012 - Rubber Plug (Water Tray)          | FSHW09A1A     | 1   |
| 18  | 69700644    | 1521212901 - Stepping Motor                  | FSHW09A1A     | 1   |
| 19  | 69700358    | 73012005 - Crank                             | FSHW09A1A     | 1   |
| 20  | 69700646    | 10000204469 - Electric Box Assy              | FSHW09A1A     | 1   |
| 21  | 69700647    | 10542036 - Axile Bush                        | FSHW09A1A     | 1   |
| 22  | 69700130    | 42011233 - Terminal Board                    | FSHW09A1A     | 1   |
| 23  | 69700649    | 4202021903 - Jumper                          | FSHW09A1A     | 1   |
| 24  | 69700650    | 300002000307 - Main Board                    | FSHW09A1A     | 1   |
| 25  | 69700651    | 140206501 - Electric Box Cover Sub-Assy      | FSHW09A1A     | 1   |
| 26  | 69700652    | 1592150 - Shield Cover of Electric Box Cover | FSHW09A1A     | 1   |
| 27  | 69700653    | 2011220701 - Electric Box Cover              | FSHW09A1A     | 1   |
| 28  | #N/A        | #N/A   | FSHW09A1A     | 1   |
| 29  | #N/A        | #N/A   | FSHW09A1A     | 1   |
| 30  | #N/A        | #N/A   | FSHW09A1A     | 1   |
| 31  | 69700657    | 305001000085 - Remote Controller             | FSHW09A1A     | 1   |
| 32  | 69700658    | 409000003 - Checking Panel Assy              | FSHW09A1A     | 1   |
| -ITEMS ARE NON- ILLUSTRATED                                       |             |  |               |     |
| *ITEMS ARE NON-STOCKED, WILL NORMALLY REQUIRE 2-3 WEEKS LEAD TIME |             |  |               |     |

# PARTS CATALOG

## 12k Indoor Unit

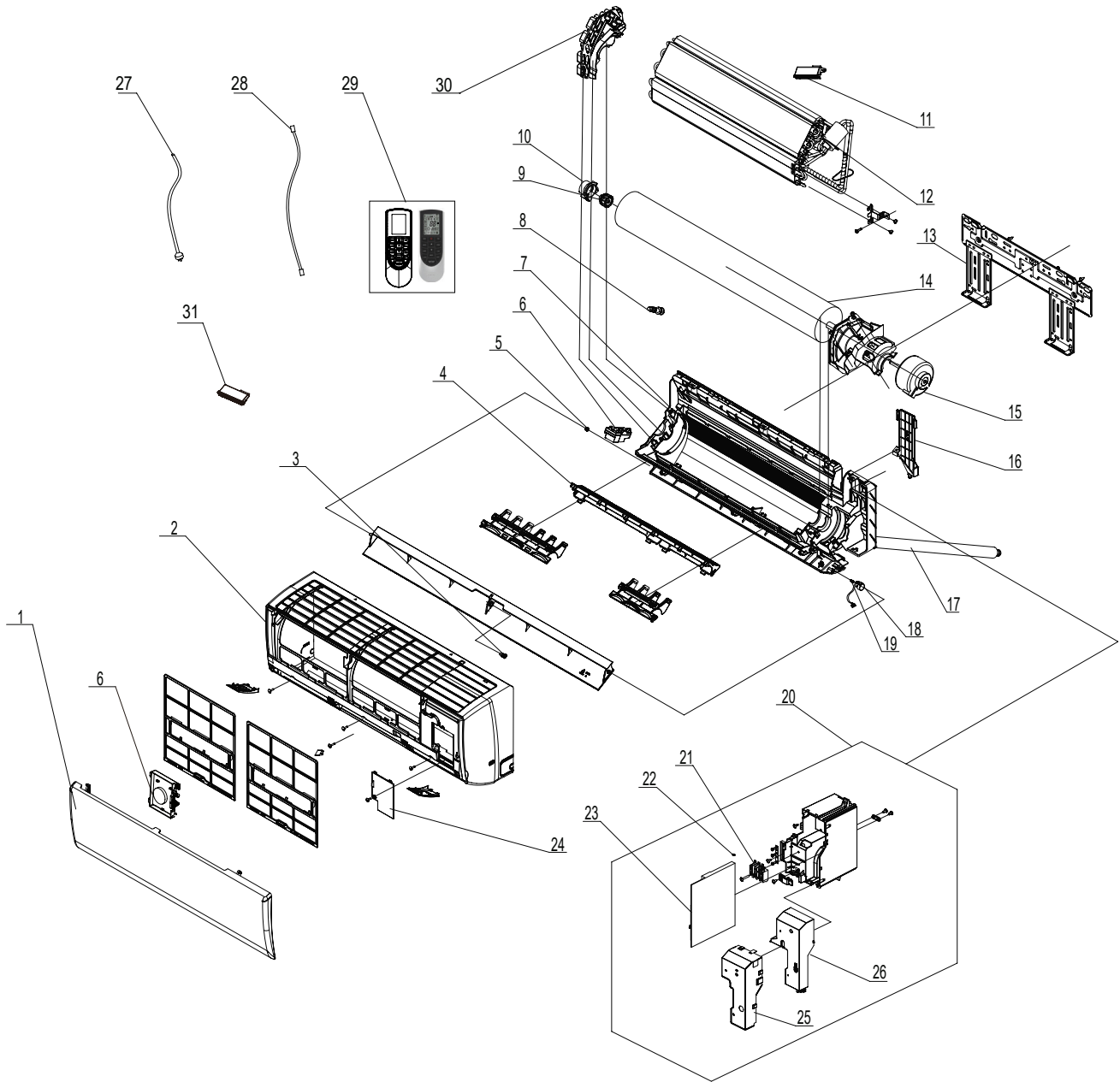

Figure 902

# PARTS CATALOG

## 12k Indoor Unit

| FIGURE 902  |             |  |               |     |
|---|-------------|--|---------------|-----|
| ITEM  | PART NUMBER | PART DESCRIPTION                             | USED ON MODEL | QTY |
| 1   | 69700659    | 300022 - Front Panel Assy                    | FSHSW12A1A    | 1   |
| 2   | 69700628    | 30565260 - Display Board                     | FSHSW12A1A    | 2   |
| 3   | 69700661    | 200022 - Front Case Assy                     | FSHSW12A1A    | 1   |
| 4   | 69700662    | 26112436 - Helicoid Tongue                   | FSHSW12A1A    | 1   |
| 5   | 69700631    | 10512037 - Left Axile Bush                   | FSHSW12A1A    | 1   |
| 6   | 69700664    | 100093 - Rear Case assy                      | FSHSW12A1A    | 1   |
| 7   | 69700665    | 5230014 - Drainage Hose                      | FSHSW12A1A    | 1   |
| 8   | 69700666    | 26152022 - Ring of Bearing                   | FSHSW12A1A    | 2   |
| 9   | 69700635    | 7651205102 - O-Gasket sub-assy of Bearing    | FSHSW12A1A    | 2   |
| 10  | 69700668    | 24212179 - Evaporator support                | FSHSW12A1A    | 1   |
| 11  | #N/A        | #N/A   | FSHSW12A1A    | 1   |
| 12  | 69700670    | 100297601 - Evaporator Assy                  | FSHSW12A1A    | 1   |
| 13  | 69700333    | 1252484 - Wall Mounting Frame                | FSHSW12A1A    | 1   |
| 14  | 69700672    | 10352056 - Cross Flow Fan                    | FSHSW12A1A    | 1   |
| 15  | 69700673    | 1501214605 - Fan Motor                       | FSHSW12A1A    | 1   |
| 16  | 69700642    | 2611216401 - Connecting pipe clamp           | FSHSW12A1A    | 1   |
| 17  | 69700481    | 76712012 - Rubber Plug (Water Tray)          | FSHSW12A1A    | 1   |
| 18  | 69700676    | 1521210710 - SteppingMotor                   | FSHSW12A1A    | 1   |
| 19  | 69700358    | 73012005 - Crank                             | FSHSW12A1A    | 1   |
| 20  | 69700678    | 10000204444 - Electric Box Assy              | FSHSW12A1A    | 1   |
| 21  | 69700647    | 10542036 - Axile Bush                        | FSHSW12A1A    | 1   |
| 22  | 69700130    | 42011233 - Terminal Board                    | FSHSW12A1A    | 1   |
| 23  | 69700681    | 4202021906 - Jumper                          | FSHSW12A1A    | 1   |
| 24  | 69700650    | 300002000307 - Main Board                    | FSHSW12A1A    | 1   |
| 25  | 69700651    | 140206501 - Electric Box Cover Sub-Assy      | FSHSW12A1A    | 1   |
| 26  | 69700652    | 1592150 - Shield Cover of Electric Box Cover | FSHSW12A1A    | 1   |
| 27  | 69700653    | 2011220701 - Electric Box Cover              | FSHSW12A1A    | 1   |
| 28  | #N/A        | #N/A   | FSHSW12A1A    | 1   |
| 29  | #N/A        | #N/A   | FSHSW12A1A    | 1   |
| 30  | #N/A        | #N/A   | FSHSW12A1A    | 1   |
| 31  | 69700657    | 305001000085 - Remote Controller             | FSHSW12A1A    | 1   |
| 32  | 69700690    | 409000004 - Checking Panel Assy              | FSHSW12A1A    | 1   |
| -ITEMS ARE NON- ILLUSTRATED                                       |             |  |               |     |
| *ITEMS ARE NON-STOCKED, WILL NORMALLY REQUIRE 2-3 WEEKS LEAD TIME |             |  |               |     |

# PARTS CATALOG

## 18K Indoor Unit

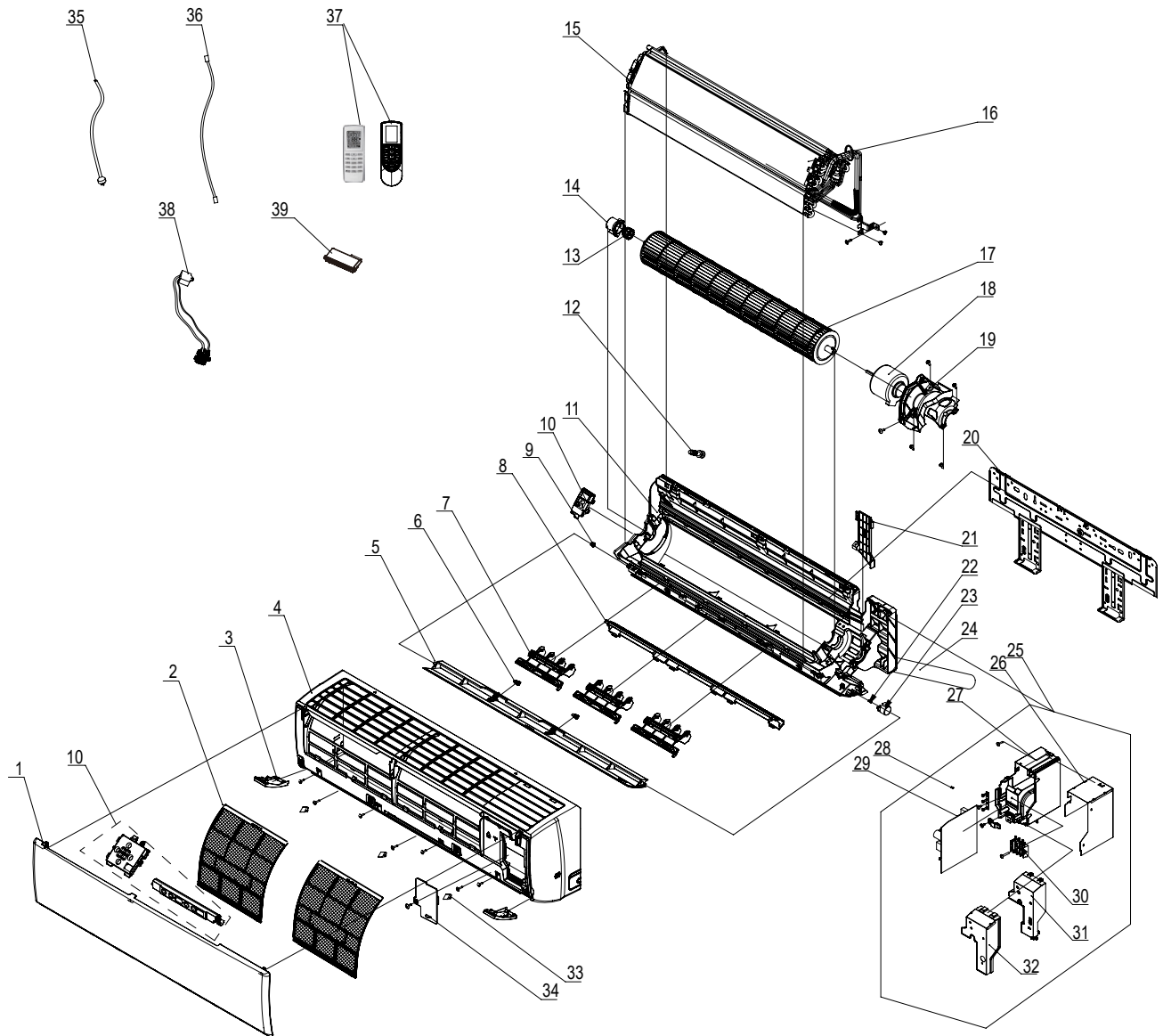

Figure 903

| ITEM | PART NUMBER | PART DESCRIPTION                     | USED ON MODEL | QTY |
|------|-------------|--------------------------------------|---------------|-----|
| 1    | 69700691    | 20192703P - Decorative Strip         | FSHW18A3A     | 1   |
| 2    | 69700692    | 300035 - Front Panel Assy            | FSHW18A3A     | 1   |
| 3    | 69700628    | 30565260 - Display Board             | FSHW18A3A     | 1   |
| 4    | 69700694    | 11122089 - Filter Sub-Assy           | FSHW18A3A     | 2   |
| 5    | 69700695    | 2019261201 - Decorative Board (Left) | FSHW18A3A     | 1   |
| 6    | 69700696    | 200023 - Front Case Assy             | FSHW18A3A     | 1   |
| 7    | 69700697    | 1051273402 - Guide Louver            | FSHW18A3A     | 1   |
| 8    | 69700647    | 10542036 - Axile Bush                | FSHW18A3A     | 2   |
| 9    | 69700699    | 10512732 - Air Louver(Manual)        | FSHW18A3A     | 3   |

# PARTS CATALOG

## 18K Indoor Unit

Figure 903

| ITEM | PART NUMBER | PART DESCRIPTION                          | USED ON MODEL | QTY |
|------|-------------|---|---------------|-----|
| 10   | 69700700    | 26112512 - Helicoid Tongue                | FSHW18A3A     | 1   |
| 11   | 69700631    | 10512037 - Left Axile Bush                | FSHW18A3A     | 1   |
| 12   | 69700702    | 22202571 - Rear Case assy                 | FSHW18A3A     | 1   |
| 13   | 69700481    | 76712012 - Rubber Plug (Water Tray)       | FSHW18A3A     | 1   |
| 14   | 69700635    | 7651205102 - O-Gasket sub-assy of Bearing | FSHW18A3A     | 1   |
| 15   | 69700741    | 26152025 - Ring of Bearing                | FSHW18A3A     | 1   |
| 16   | 69700706    | 24212177 - Evaporator Support             | FSHW18A3A     | 1   |
| 17   | 69700707    | 11001000207 - Evaporator Assy             | FSHW18A3A     | 1   |
| 18   | 69700708    | 10352060 - Cross Flow Fan                 | FSHW18A3A     | 1   |
| 19   | 69700709    | 1501214503 - Fan Motor                    | FSHW18A3A     | 1   |
| 20   | 69700710    | 26112511 - Motor Press Plate              | FSHW18A3A     | 1   |
| 21   | 69700711    | 1362026 - Wall Mounting Frame             | FSHW18A3A     | 1   |
| 22   | 69700712    | 2611218801 - Connecting pipe clamp        | FSHW18A3A     | 1   |
| 23   | 69700358    | 73012005 - Crank                          | FSHW18A3A     | 1   |
| 24   | 69700714    | 1521240212 - Stepping Motor               | FSHW18A3A     | 1   |
| 25   | 69700665    | 5230014 - Drainage Hose                   | FSHW18A3A     | 1   |
| 26   | 69700716    | 10000204259 - Electric Box Assy           | FSHW18A3A     | 1   |
| 27   | 69700717    | 1592139 - Lower Shield of Electric Box    | FSHW18A3A     | 1   |
| 28   | 69700718    | 2011221102 - Electric Box                 | FSHW18A3A     | 1   |
| 29   | 69700719    | 4202021909 - Jumper                       | FSHW18A3A     | 1   |
| 30   | 69700720    | 300002000312 - Main Board                 | FSHW18A3A     |     |
| 31   | 69700721    | 1592176 - Shield Cover of Electric Box    | FSHW18A3A     |     |
| 32   | 69700722    | 2011220901 - Electric Box Cover           | FSHW18A3A     |     |
| 33   | 69700130    | 42011233 - Terminal Board                 | FSHW18A3A     |     |
| 34   | 69700724    | 2019261101 - Decorative Board (Right)     | FSHW18A3A     |     |
| 35   | 69700725    | 2425201726 - Screw Cover                  | FSHW18A3A     |     |
| 36   | 69700726    | 2011221001 - Electric Box Cover2          | FSHW18A3A     |     |
| 37   | #N/A        | #N/A                                      | FSHW18A3A     |     |
| 38   | #N/A        | #N/A                                      | FSHW18A3A     |     |
| 39   | #N/A        | #N/A                                      | FSHW18A3A     |     |
| 40   | 69700657    | 305001000085 - Remote Controller          | FSHW18A3A     |     |
| 41   | #N/A        | #N/A                                      | FSHW18A3A     |     |

-ITEMS ARE NON- ILLUSTRATED

\*ITEMS ARE NON-STOCKED, WILL NORMALLY REQUIRE 2-3 WEEKS LEAD TIME

# PARTS CATALOG

## 24K Indoor Unit

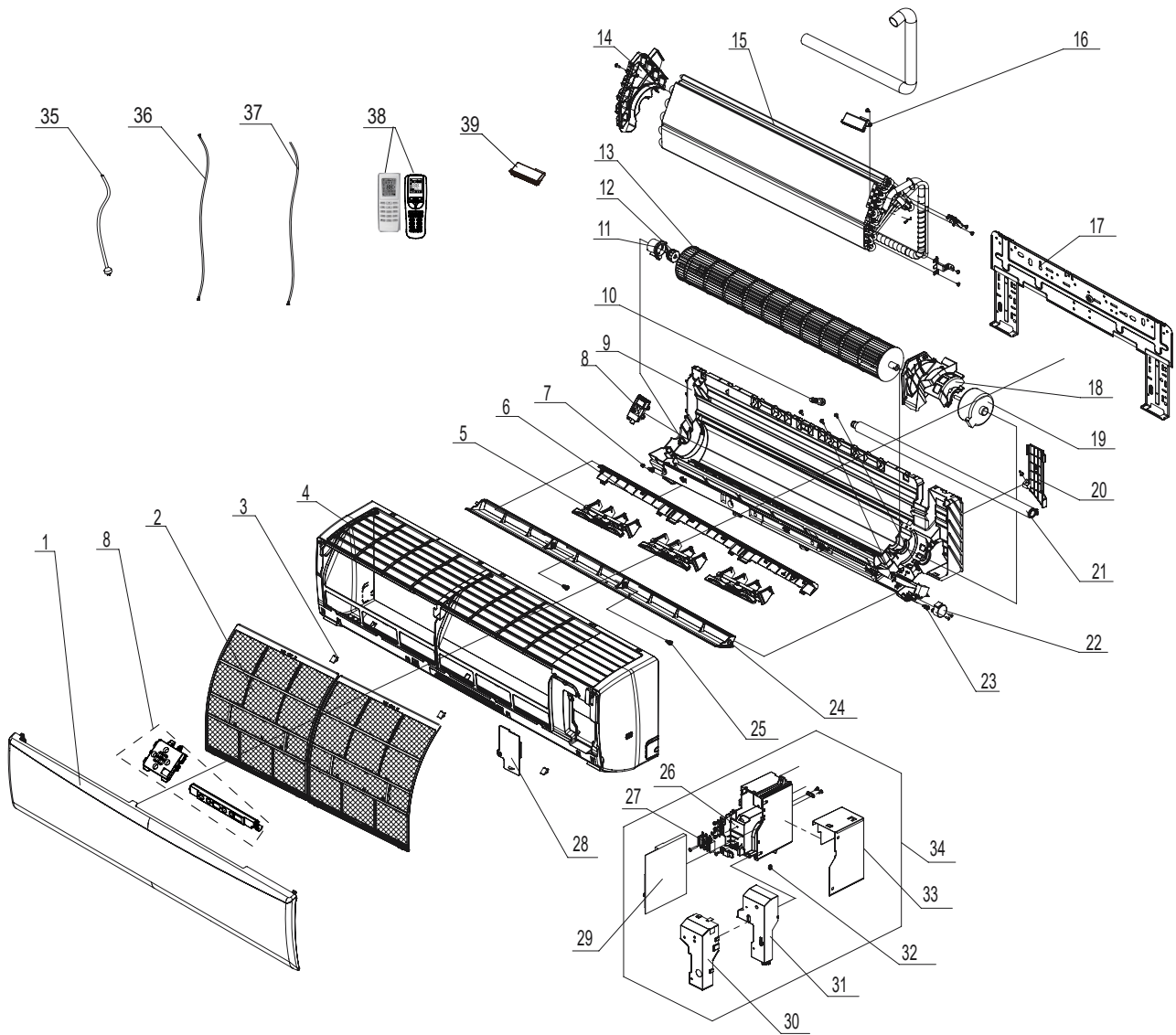

Figure 904

| ITEM | PART NUMBER | PART DESCRIPTION                    | USED ON MODEL | QTY |
|------|-------------|-------------------------------------|---------------|-----|
| 1    | 69700732    | 300021 - Front Panel Assy           | FSHW24A3A     | 1   |
| 2    | 69700733    | 11012007 - Filter Sub-Assy          | FSHW24A3A     | 1   |
| 3    | 69700734    | 2425245301 - Screw Cover            | FSHW24A3A     | 1   |
| 4    | 69700735    | 200116 - Front Case Assy            | FSHW24A3A     | 1   |
| 5    | 69700736    | 10512737 - Air Louver(Manual)       | FSHW24A3A     | 1   |
| 6    | 69700737    | 26112382 - Helicoid Tongue sub-assy | FSHW24A3A     | 1   |
| 7    | 69700631    | 10512037 - Left Axile Bush          | FSHW24A3A     | 1   |
| 8    | 69700739    | 22202570 - Rear Case assy           | FSHW24A3A     | 1   |
| 9    | 69700481    | 76712012 - Rubber Plug (Water Tray) | FSHW24A3A     | 1   |
| 10   | 69700741    | 26152025 - Ring of Bearing          | FSHW24A3A     | 1   |

# PARTS CATALOG

## 24K Indoor Unit

| Figure 904  |             |   |               |     |
|---|-------------|---|---------------|-----|
| ITEM  | PART NUMBER | PART DESCRIPTION                          | USED ON MODEL | QTY |
| 11  | 69700635    | 7651205102 - O-Gasket sub-assy of Bearing | FSHW24A3A     | 1   |
| 12  | 69700743    | 10352057 - Cross Flow Fan                 | FSHW24A3A     | 1   |
| 13  | 69700744    | 24212178 - Evaporator Support             | FSHW24A3A     | 1   |
| 14  | 69700745    | 11001000095 - Evaporator Assy             | FSHW24A3A     | 1   |
| 15  | #N/A        | #N/A                                      | FSHW24A3A     | 1   |
| 16  | 69700747    | 1252229 - Wall Mounting Frame             | FSHW24A3A     | 1   |
| 17  | 69700748    | 26112515 - Motor Press Plate              | FSHW24A3A     | 1   |
| 18  | 69700749    | 1501214501 - Fan Motor                    | FSHW24A3A     | 1   |
| 19  | 69700750    | 26112514 - Connecting pipe clamp          | FSHW24A3A     | 1   |
| 20  | 69700751    | 523001405 - Drainage Hose                 | FSHW24A3A     | 1   |
| 21  | 69700714    | 1521240212 - Stepping Motor               | FSHW24A3A     | 1   |
| 22  | 69700358    | 73012005 - Crank                          | FSHW24A3A     | 1   |
| 23  | 69700754    | 1051273802 - Guide Louver                 | FSHW24A3A     | 1   |
| 24  | 69700647    | 10542036 - Axile Bush                     | FSHW24A3A     | 1   |
| 25  | 69700718    | 2011221102 - Electric Box                 | FSHW24A3A     | 1   |
| 26  | 69700130    | 42011233 - Terminal Board                 | FSHW24A3A     | 1   |
| 27  | 69700726    | 2011221001 - Electric Box Cover2          | FSHW24A3A     | 1   |
| 28  | 69700759    | 300002000316 - Main Board                 | FSHW24A3A     | 1   |
| 29  | 69700628    | 30565260 - Display Board                  | FSHW24A3A     | 1   |
| 30  | 69700721    | 1592176 - Shield Cover of Electric Box    | FSHW24A3A     | 1   |
| 31  | 69700722    | 2011220901 - Electric Box Cover           | FSHW24A3A     | 1   |
| 32  | 69700763    | 4202021915 - Jumper                       | FSHW24A3A     | 1   |
| 33  | 69700717    | 1592139 - Lower Shield of Electric Box    | FSHW24A3A     | 1   |
| 34  | 69700765    | 100002001407 - Electric Box Assy          | FSHW24A3A     | 1   |
| 35  | #N/A        | #N/A                                      | FSHW24A3A     | 1   |
| 36  | #N/A        | #N/A                                      | FSHW24A3A     | 1   |
| 37  | #N/A        | #N/A                                      | FSHW24A3A     | 1   |
| 38  | 69700769    | 3900031302 - Temperature Sensor           | FSHW24A3A     | 1   |
| 39  | 69700657    | 305001000085 - Remote Controller          | FSHW24A3A     | 1   |
| -ITEMS ARE NON- ILLUSTRATED                                       |             |   |               |     |
| *ITEMS ARE NON-STOCKED, WILL NORMALLY REQUIRE 2-3 WEEKS LEAD TIME |             |   |               |     |

# PARTS CATALOG

## 36K Indoor Unit

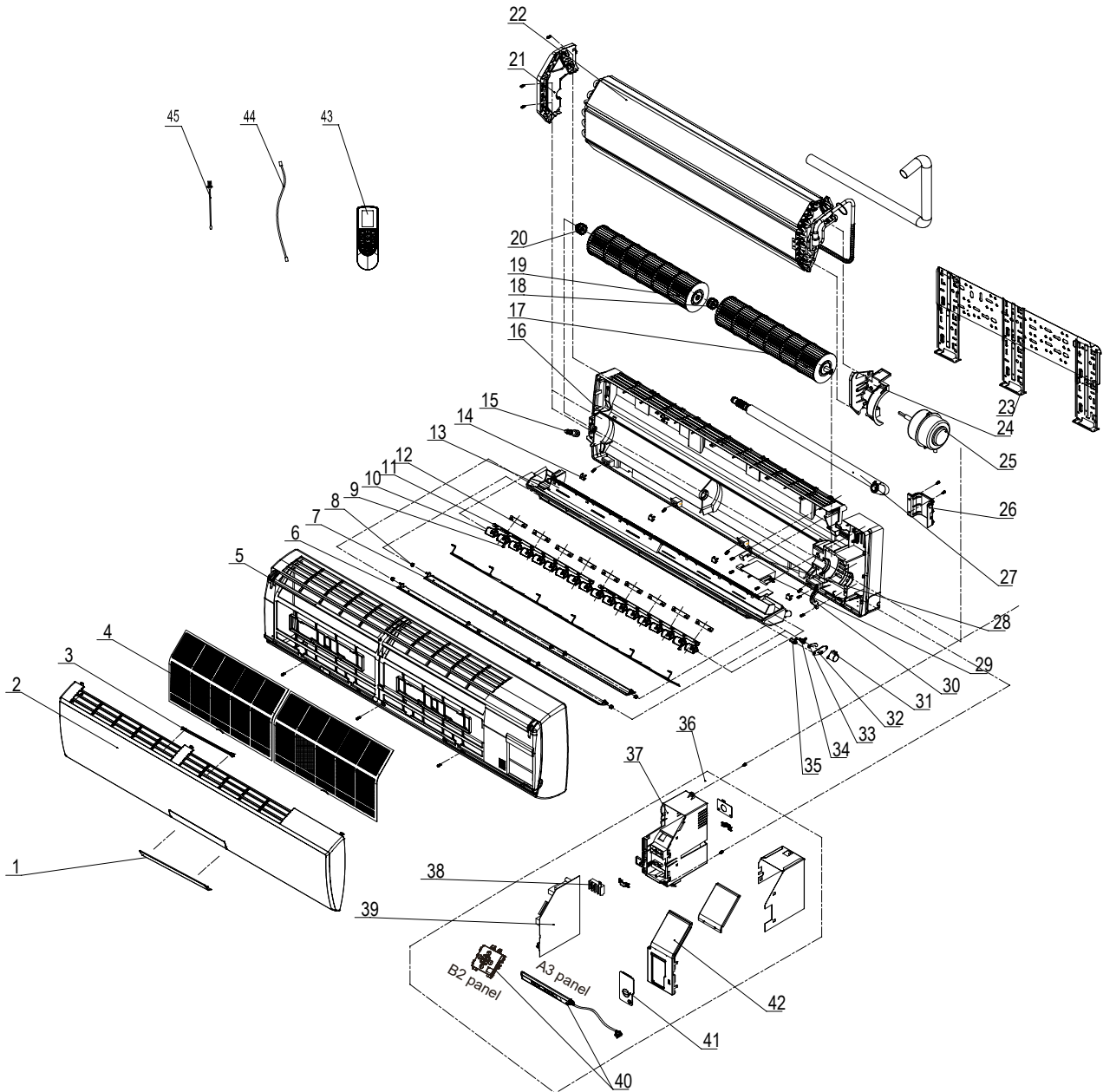

Figure 905

| ITEM | PART NUMBER | PART DESCRIPTION                         | USED ON MODEL | QTY |
|------|-------------|--|---------------|-----|
| 1    | 69700592    | 22430024 - Receiver Window/DISPLAY COVER | FSHSW36A3A    | 1   |
| 2    | 69700593    | 20000300022S - Front Panel               | FSHSW36A3A    | 1   |
| 3    | 69700594    | 2421212001 - Stand Bar                   | FSHSW36A3A    | 1   |
| 4    | 69700470    | 11122106 - Filter Sub-Assy               | FSHSW36A3A    | 1   |
| 5    | 69700596    | 20900700005 - Front Case Sub-Assy        | FSHSW36A3A    | 1   |
| 6    | 69700597    | 1051216601 - Upper Guide Louver          | FSHSW36A3A    | 1   |



# PARTS CATALOG

## 36K Indoor Unit

| Figure 905   |             |  |               |     |
|--|-------------|--|---------------|-----|
| ITEM   | PART NUMBER | PART DESCRIPTION                                   | USED ON MODEL | QTY |
| 7  | 69700598    | 1051216701 - Lower Guide Louver                    | FSHSW36A3A    | 1   |
| 8  | 69700599    | 1051216902 - Air Louver 2                          | FSHSW36A3A    | 1   |
| 9  | 69700600    | 1051216802 - Air Louver 1                          | FSHSW36A3A    | 1   |
| 10   | 69700477    | 10582086 - Connecting Rod/LOUVER ROD               | FSHSW36A3A    | 1   |
| 11   | 69700478    | 26112158 - Louver Clamp                            | FSHSW36A3A    | 1   |
| 12   | 69700603    | 2018213802 - Water Tray/DRAIN PAN                  | FSHSW36A3A    | 1   |
| 13   | 69700604    | 2425200506 - Screw Cover/SCREW PLUGS               | FSHSW36A3A    | 1   |
| 14   | 69700481    | 76712012 - Rubber Plug (Water Tray)                | FSHSW36A3A    | 1   |
| 15   | 69700606    | 100113 - Rear Case assy                            | FSHSW36A3A    | 1   |
| 16   | 69700483    | 10352039 - Cross Flow Fan 1/<br>BLOWER 1           | FSHSW36A3A    | 1   |
| 17   | 69700485    | 10352040 - Cross Flow Fan 2/<br>BLOWER 2           | FSHSW36A3A    | 1   |
| 18   | 69700487    | 24212041 - Left Evaporator Support                 | FSHSW36A3A    | 1   |
| 19   | 69700610    | 1002000027 - Evaporator Assy/COIL                  | FSHSW36A3A    | 1   |
| 20   | 69700489    | 1252398 - Wall Mounting Frame                      | FSHSW36A3A    | 1   |
| 21   | 69700612    | 1501213401 - Fan Motor                             | FSHSW36A3A    | 1   |
| 22   | 69700491    | 26112071 - Pipe Clamp                              | FSHSW36A3A    | 1   |
| 23   | 69700614    | 523001404 - Drainage Hose                          | FSHSW36A3A    | 1   |
| 24   | 69700615    | 2012212402 - Cover Plate                           | FSHSW36A3A    | 1   |
| 25   | 69700494    | 26112324 - Motor Fixed Clip 1/MOTOR RETAINER       | FSHSW36A3A    | 1   |
| 26   | 69700617    | 1521210701 - SteppingMotor                         | FSHSW36A3A    | 1   |
| 27   | 69700618    | 100002001022 - Electric Box Assy/<br>PCB BOARD BOX | FSHSW36A3A    | 1   |
| 28   | #N/A        | #N/A   | FSHSW36A3A    | 1   |
| 29   | 69700130    | 42011233 - Terminal Board                          | FSHSW36A3A    | 1   |
| 30   | 69700621    | 300002000255 - Main Board                          | FSHSW36A3A    | 1   |
| 31   | 69700622    | 30565277 - Display Board                           | FSHSW36A3A    | 1   |
| 32   | 69700623    | 30510475 - Remote Control                          | FSHSW36A3A    | 1   |
| 33   | 69700624    | 4001024507 - Signal Wire                           | FSHSW36A3A    | 1   |
| 34   | 69700510    | 390000592 - Temperature Sensor/<br>THERMISTOR      | FSHSW36A3A    | 1   |
| 35   | 69700363    | 390000453 - Temperature Sensor/<br>THERMISTOR      | FSHSW36A3A    | 1   |
| -ITEMS ARE NON- ILLUSTRATED<br>*ITEMS ARE NON-STOCKED, WILL NORMALLY REQUIRE 2-3 WEEKS LEAD TIME |             |  |               |     |

# PARTS CATALOG

## 9K Outdoor Unit

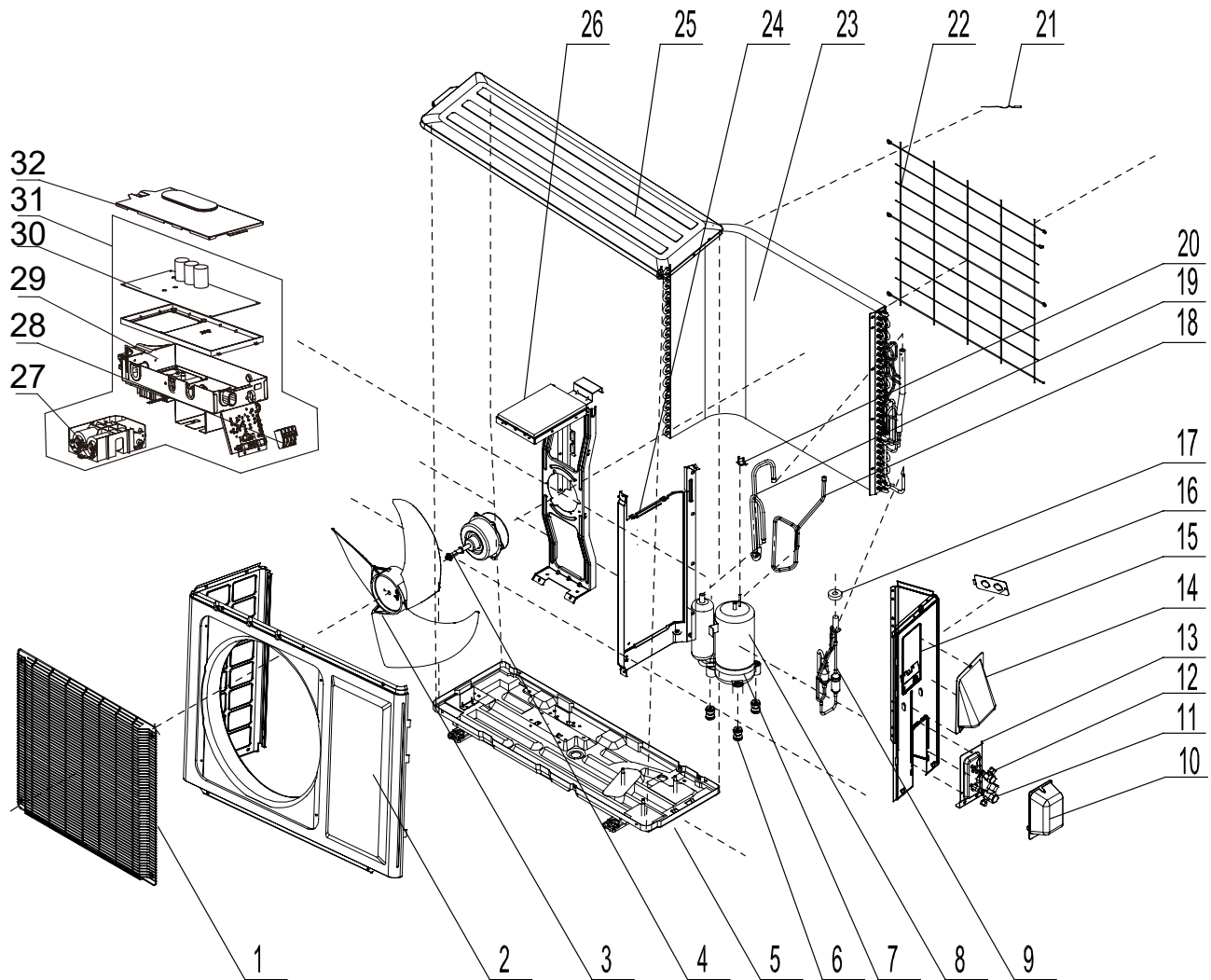

Figure 906

# PARTS CATALOG

## 9K Outdoor Unit

| Figure 906  |             |  |               |     |
|---|-------------|--|---------------|-----|
| ITEM  | PART NUMBER | PART DESCRIPTION                                 | USED ON MODEL | QTY |
| 1   | 69700000    | 1473012 - Front Grill                            | FSHSR09A1A    | 1   |
| 2   | 69700772    | 153304901 - Front Panel Assy                     | FSHSR09A1A    | 1   |
| 3   | 69700773    | 10333004 - Axial Flow Fan                        | FSHSR09A1A    | 1   |
| 4   | 69700774    | 1501308507 - Fan Motor                           | FSHSR09A1A    | 1   |
| 5   | 69700775    | 0120388105P - Chassis Sub-assy                   | FSHSR09A1A    | 1   |
| 6   | #N/A        | #N/A   | FSHSR09A1A    | 1   |
| 7   | 69700777    | 76710302 - Compressor Gasket                     | FSHSR09A1A    | 1   |
| 8   | 69700268    | 103862 - Compressor and Fittings                 | FSHSR09A1A    | 1   |
| 9   | 69700779    | 30026000199 - Electric Expansion Valve Sub-Assy  | FSHSR09A1A    | 1   |
| 10  | 69700780    | 2012300101 - Valve Cover                         | FSHSR09A1A    | 1   |
| 11  | 69700009    | 7100003 - Valve                                  | FSHSR09A1A    | 1   |
| 12  | 69700010    | 7100005 - Valve                                  | FSHSR09A1A    | 1   |
| 13  | 69700011    | 1713041 - Valve Support                          | FSHSR09A1A    | 1   |
| 14  | 69700276    | 02123014P - Cable Cross Plate 2                  | FSHSR09A1A    | 1   |
| 15  | 69700785    | 02123013P - Cable Cross Plate 1                  | FSHSR09A1A    | 1   |
| 16  | 69700786    | 13030713 - Right Side Plate Assy                 | FSHSR09A1A    | 1   |
| 17  | 69700787    | 1413069 - Cover of Pass Wire                     | FSHSR09A1A    | 1   |
| 18  | 69700788    | 4300876701 - Electric Expand Valve Fitting       | FSHSR09A1A    | 1   |
| 19  | 69700283    | 39000310 - Temperature Sensor                    | FSHSR09A1A    | 1   |
| 20  | 69700790    | 3073403 - 4-Way Valve Assy                       | FSHSR09A1A    | 1   |
| 21  | 69700213    | 4300040021 - Magnet Coil                         | FSHSR09A1A    | 1   |
| 22  | 69700792    | 180030 - Compressor Overload Protector(External) | FSHSR09A1A    | 1   |
| 23  | 69700274    | 1473057 - Rear Grill                             | FSHSR09A1A    | 1   |
| 24  | 69700794    | 11002000509 - Condenser Assy                     | FSHSR09A1A    | 1   |
| 25  | 69700795    | 1233034 - Clapboard Sub-Assy                     | FSHSR09A1A    | 1   |
| 26  | 69700796    | 5106001201 - Top Cover Sub-Assy                  | FSHSR09A1A    | 1   |
| 27  | #N/A        | #N/A   | FSHSR09A1A    | 1   |
| 28  | 69700027    | 260309601 - Electric Box Cover Sub-Assy          | FSHSR09A1A    | 1   |
| 29  | 69700799    | 300027000356 - Main Board                        | FSHSR09A1A    | 1   |
| 30  | 69700800    | 100002061853 - Electric Box Assy                 | FSHSR09A1A    | 1   |
| 31  | 69700803    | 42010255 - Terminal Board                        | FSHSR09A1A    | 1   |
| -32   | 69700801    | 100002001953 - Electric Box Assy                 | FSHSR09A1A    | 1   |
| -33   | n/a         | n/a  | n/a           | 0   |
| -ITEMS ARE NON- ILLUSTRATED                                       |             |  |               |     |
| *ITEMS ARE NON-STOCKED, WILL NORMALLY REQUIRE 2-3 WEEKS LEAD TIME |             |  |               |     |

# PARTS CATALOG

## 12k Outdoor Unit

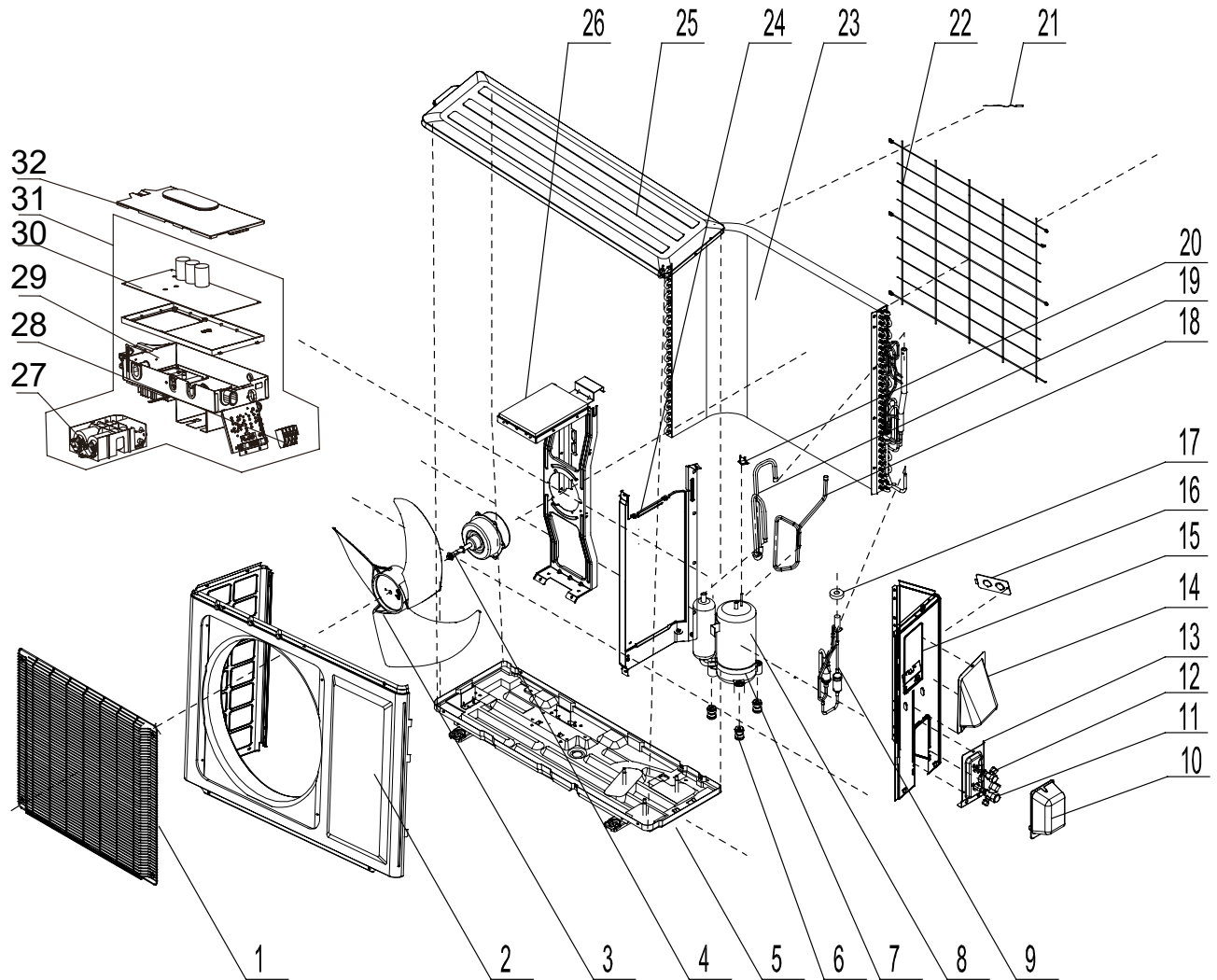

Figure 907

# PARTS CATALOG

## 12k Outdoor Unit

| Figure 907  |             |  |               |     |
|---|-------------|--|---------------|-----|
| ITEM  | PART NUMBER | PART DESCRIPTION                                 | USED ON MODEL | QTY |
| 1   | 69700000    | 1473012 - Front Grill                            | FSHSR12A1A    | 1   |
| 2   | 69700772    | 153304901 - Front Panel Assy                     | FSHSR12A1A    | 1   |
| 3   | 69700773    | 10333004 - Axial Flow Fan                        | FSHSR12A1A    | 1   |
| 4   | 69700774    | 1501308507 - Fan Motor                           | FSHSR12A1A    | 1   |
| 5   | 69700808    | 0120388103P - Chassis Sub-assy                   | FSHSR12A1A    | 1   |
| 6   | #N/A        | #N/A   | FSHSR12A1A    | 1   |
| 7   | 69700777    | 76710302 - Compressor Gasket                     | FSHSR12A1A    | 1   |
| 8   | 69700268    | 103862 - Compressor and Fittings                 | FSHSR12A1A    | 1   |
| 9   | 69700812    | 30026000185 - Electric Expansion Valve Sub-Assy  | FSHSR12A1A    | 1   |
| 10  | 69700780    | 2012300101 - Valve Cover                         | FSHSR12A1A    | 1   |
| 11  | 69700814    | 7130239 - Cut off Valve                          | FSHSR12A1A    | 1   |
| 12  | 69700010    | 7100005 - Valve                                  | FSHSR12A1A    | 1   |
| 13  | 69700011    | 1713041 - Valve Support                          | FSHSR12A1A    | 1   |
| 14  | 69700276    | 02123014P - Cable Cross Plate 2                  | FSHSR12A1A    | 1   |
| 15  | 69700785    | 02123013P - Cable Cross Plate 1                  | FSHSR12A1A    | 1   |
| 16  | 69700786    | 13030713 - Right Side Plate Assy                 | FSHSR12A1A    | 1   |
| 17  | 69700787    | 1413069 - Cover of Pass Wire                     | FSHSR12A1A    | 1   |
| 18  | 69700788    | 4300876701 - Electric Expand Valve Fitting       | FSHSR12A1A    | 1   |
| 19  | 69700822    | 3900030903 - Temperature Sensor                  | FSHSR12A1A    | 1   |
| 20  | 69700790    | 3073403 - 4-Way Valve Assy                       | FSHSR12A1A    | 1   |
| 21  | 69700213    | 4300040021 - Magnet Coil                         | FSHSR12A1A    | 1   |
| 22  | 69700792    | 180030 - Compressor Overload Protector(External) | FSHSR12A1A    | 1   |
| 23  | 69700274    | 1473057 - Rear Grill                             | FSHSR12A1A    | 1   |
| 24  | 69700827    | 11002000466 - Condenser Assy                     | FSHSR12A1A    | 1   |
| 25  | 69700795    | 1233034 - Clapboard Sub-Assy                     | FSHSR12A1A    | 1   |
| 26  | 69700796    | 5106001201 - Top Cover Sub-Assy                  | FSHSR12A1A    | 1   |
| 27  | #N/A        | #N/A   | FSHSR12A1A    | 1   |
| 28  | 69700027    | 260309601 - Electric Box Cover Sub-Assy          | FSHSR12A1A    | 1   |
| 29  | 69700832    | 300027000325 - Main Board                        | FSHSR12A1A    | 1   |
| 30  | 69700833    | 100002061852 - Electric Box Assy                 | FSHSR12A1A    | 1   |
| 31  | 69700803    | 42010255 - Terminal Board                        | FSHSR12A1A    | 1   |
| -32   | 69700834    | 100002001751 - Electric Box Assy                 | FSHSR12A1A    | 1   |
| -33   | #N/A        | #N/A   | FSHSR12A1A    | 0   |
| -ITEMS ARE NON- ILLUSTRATED                                       |             |  |               |     |
| *ITEMS ARE NON-STOCKED, WILL NORMALLY REQUIRE 2-3 WEEKS LEAD TIME |             |  |               |     |

# PARTS CATALOG

## 18k Outdoor Unit

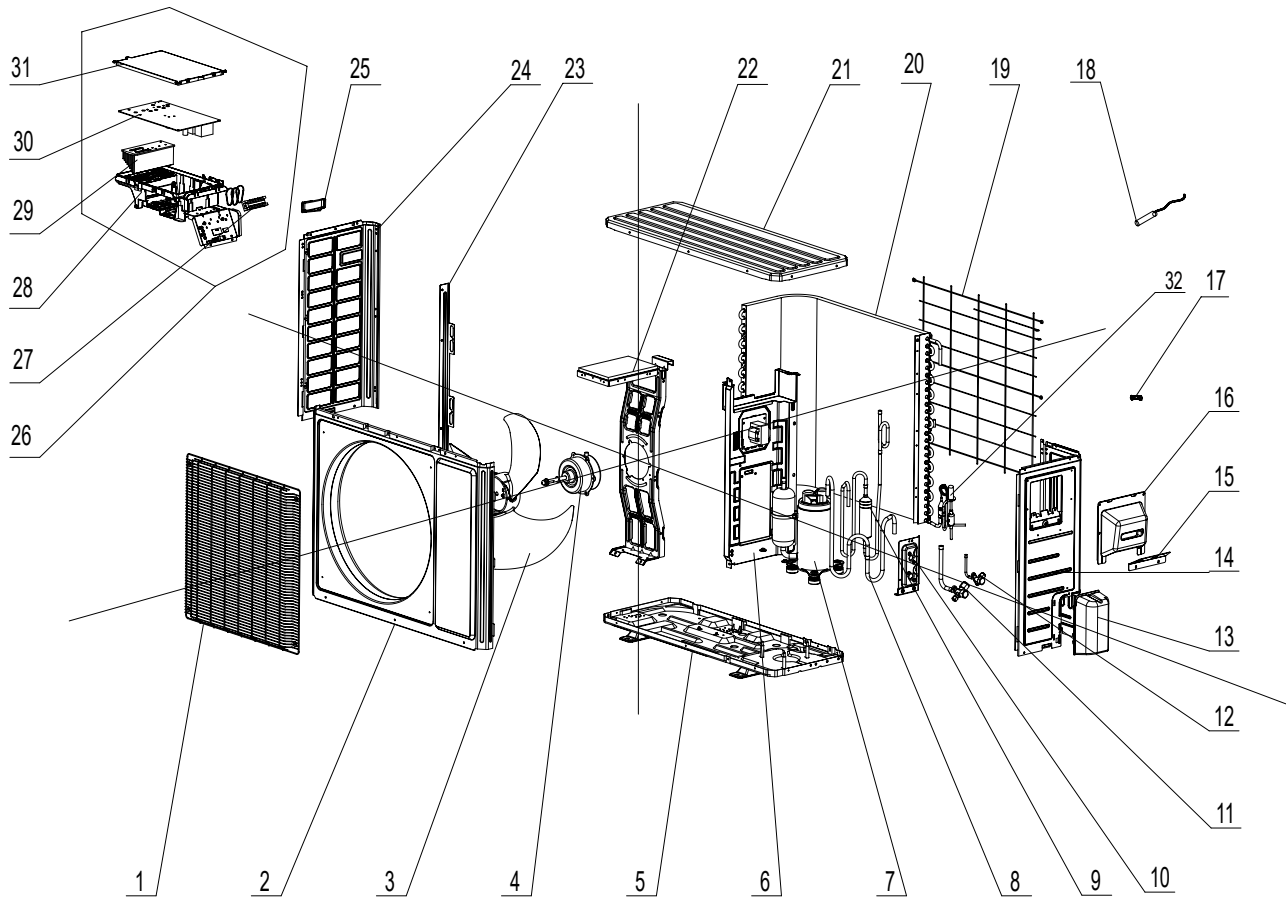

Figure 908

# PARTS CATALOG

## 18kOutdoor Unit

| Figure 908  |             |                                     |               |     |
|---|-------------|-------------------------------------|---------------|-----|
| ITEM  | PART NUMBER | PART DESCRIPTION                    | USED ON MODEL | QTY |
| 1   | 69700837    | 16004000006 - Front Grill           | FSHSR18A3A    | 1   |
| 2   | 69700838    | 3060055 - Front Panel Assy          | FSHSR18A3A    | 1   |
| 3   | 69700839    | 10335008 - Axial Flow Fan           | FSHSR18A3A    | 1   |
| 4   | 69700840    | 01700000093P - Chassis Sub-assy     | FSHSR18A3A    | 1   |
| 5   | 69700164    | 6123401 - Drainage Connector        | FSHSR18A3A    | 1   |
| 6   | 69700842    | 00105249G - Compressor and Fittings | FSHSR18A3A    | 1   |
| 7   | 69700843    | 30152000291 - 4-Way Valve Assy      | FSHSR18A3A    | 1   |
| 8   | 69700844    | 01715010P - Valve Support Assy      | FSHSR18A3A    | 1   |
| 9   | 69700845    | 71302392 - Cut off Valve            | FSHSR18A3A    | 1   |
| 10  | 69700846    | 713506803 - Cut off Valve           | FSHSR18A3A    | 1   |
| 11  | 69700847    | 22245002 - Valve Cover              | FSHSR18A3A    | 1   |
| 12  | 69700848    | 26233053 - Handle                   | FSHSR18A3A    | 1   |
| 13  | 69700849    | 130329202 - Right Side Plate Assy   | FSHSR18A3A    | 1   |
| 14  | 69700850    | 4300040045 - Magnet Coil            | FSHSR18A3A    | 1   |
| 15  | 69700851    | 26115004 - Wiring Clamp             | FSHSR18A3A    | 1   |
| 16  | 69700852    | 3900030901 - Temperature Sensor     | FSHSR18A3A    | 1   |
| 17  | 69700853    | 1473043 - Rear Grill                | FSHSR18A3A    | 1   |
| 18  | 69700854    | 11002000513 - Condenser Assy        | FSHSR18A3A    | 1   |
| 19  | 69700855    | 1233153 - Clapboard Assy            | FSHSR18A3A    | 1   |
| 20  | 69700856    | 51000017 - Coping Sub-Assy          | FSHSR18A3A    | 1   |
| 21  | 69700857    | 1703154 - Motor Support Sub-Assy    | FSHSR18A3A    | 1   |
| 22  | 69700858    | 1501506402 - Fan Motor              | FSHSR18A3A    | 1   |
| 23  | 69700859    | 1173127 - Condenser Support Plate   | FSHSR18A3A    | 1   |
| 24  | 69700860    | 01305093P - Left Side Plate         | FSHSR18A3A    | 1   |
| 25  | 69700861    | 100002001525 - Electric Box Assy    | FSHSR18A3A    | 1   |
| 26  | 69700862    | 20113027 - Electric Box             | FSHSR18A3A    | 1   |
| 27  | 69700803    | 42010255 - Terminal Board           | FSHSR18A3A    | 1   |
| 28  | 69700864    | 49013060 - Radiator                 | FSHSR18A3A    | 1   |
| 29  | 69700865    | 300027060416 - Main Board           | FSHSR18A3A    | 1   |
| -ITEMS ARE NON- ILLUSTRATED                                       |             |                                     |               |     |
| *ITEMS ARE NON-STOCKED, WILL NORMALLY REQUIRE 2-3 WEEKS LEAD TIME |             |                                     |               |     |

# PARTS CATALOG

## 24k Outdoor Unit

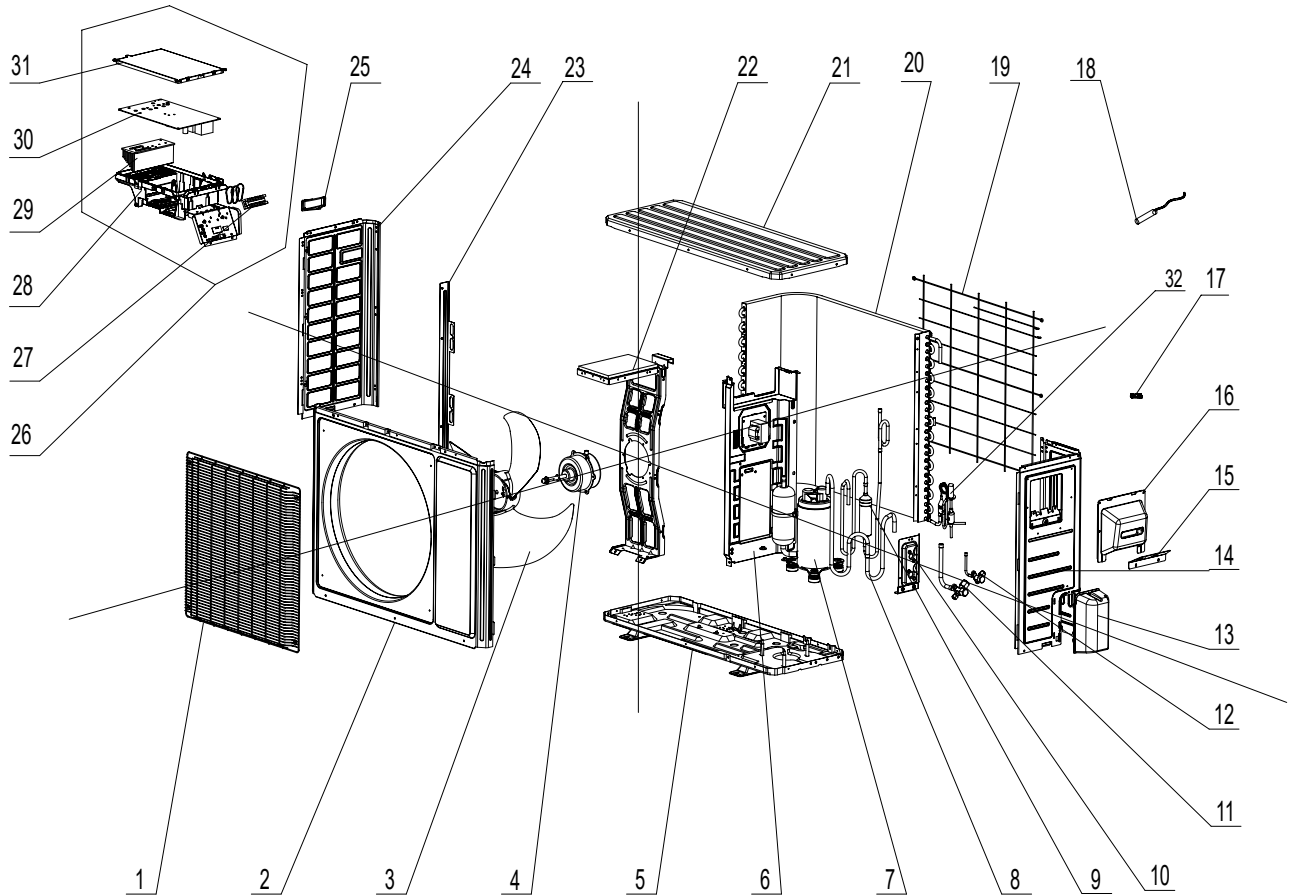

Figure 909



# PARTS CATALOG

## 24k Outdoor Unit

| Figure 909  |             |                                     |               |     |
|---|-------------|-------------------------------------|---------------|-----|
| ITEM  | PART NUMBER | PART DESCRIPTION                    | USED ON MODEL | QTY |
| 1   | 69700837    | 16004000006 - Front Grill           | FSHSR24A3A    | 1   |
| 2   | 69700838    | 3060055 - Front Panel Assy          | FSHSR24A3A    | 1   |
| 3   | 69700839    | 10335008 - Axial Flow Fan           | FSHSR24A3A    | 1   |
| 4   | #N/A        | #N/A                                | FSHSR24A3A    | 1   |
| 5   | 69700870    | 01700000161P - Chassis Sub-assy     | FSHSR24A3A    | 1   |
| 6   | #N/A        | #N/A                                | FSHSR24A3A    | 1   |
| 7   | 69700842    | 00105249G - Compressor and Fittings | FSHSR24A3A    | 1   |
| 8   | 69700873    | 430004032 - 4-Way Valve             | FSHSR24A3A    | 1   |
| 9   | 69700874    | 30152000073 - 4-Way Valve Assy      | FSHSR24A3A    | 1   |
| 10  | 69700875    | 3015737 - Capillary Tube            | FSHSR24A3A    | 1   |
| 11  | 69700814    | 7130239 - Cut off Valve             | FSHSR24A3A    | 1   |
| 12  | 69700877    | 130329208 - Right Side Plate Assy   | FSHSR24A3A    | 1   |
| 13  | 69700878    | 01705046P - Valve Support Sub-Assy  | FSHSR24A3A    | 1   |
| 14  | 69700879    | 7133844 - Cut off Valve             | FSHSR24A3A    | 1   |
| 15  | 69700848    | 26233053 - Handle                   | FSHSR24A3A    | 1   |
| 16  | #N/A        | #N/A                                | FSHSR24A3A    | 1   |
| 17  | 69700882    | 3900030902 - Temperature Sensor     | FSHSR24A3A    | 1   |
| 18  | #N/A        | #N/A                                | FSHSR24A3A    | 1   |
| 19  | 69700884    | 1475020 - Rear Grill                | FSHSR24A3A    | 1   |
| 20  | 69700885    | 11002000177 - Condenser Assy        | FSHSR24A3A    | 1   |
| 21  | 69700886    | 1235081 - Clapboard Sub-Assy        | FSHSR24A3A    | 1   |
| 22  | #N/A        | #N/A                                | FSHSR24A3A    | 1   |
| 23  | 69700888    | 1705067 - Motor Support Sub-Assy    | FSHSR24A3A    | 1   |
| 24  | 69700856    | 51000017 - Coping Sub-Assy          | FSHSR24A3A    | 1   |
| 25  | 69700860    | 01305093P - Left Side Plate         | FSHSR24A3A    | 1   |
| 26  | #N/A        | #N/A                                | FSHSR24A3A    | 1   |
| 27  | 69700803    | 42010255 - Terminal Board           | FSHSR24A3A    | 1   |
| 28  | 69700893    | 100002001406 - Electric Box Assy    | FSHSR24A3A    | 1   |
| 29  | 69700894    | 20123028 - Electric Box Cover       | FSHSR24A3A    | 1   |
| 30  | 69700895    | 300027000301 - Main Board           | FSHSR24A3A    | 1   |
| -ITEMS ARE NON- ILLUSTRATED                                       |             |                                     |               |     |
| *ITEMS ARE NON-STOCKED, WILL NORMALLY REQUIRE 2-3 WEEKS LEAD TIME |             |                                     |               |     |

# PARTS CATALOG

## 36k Outdoor Unit

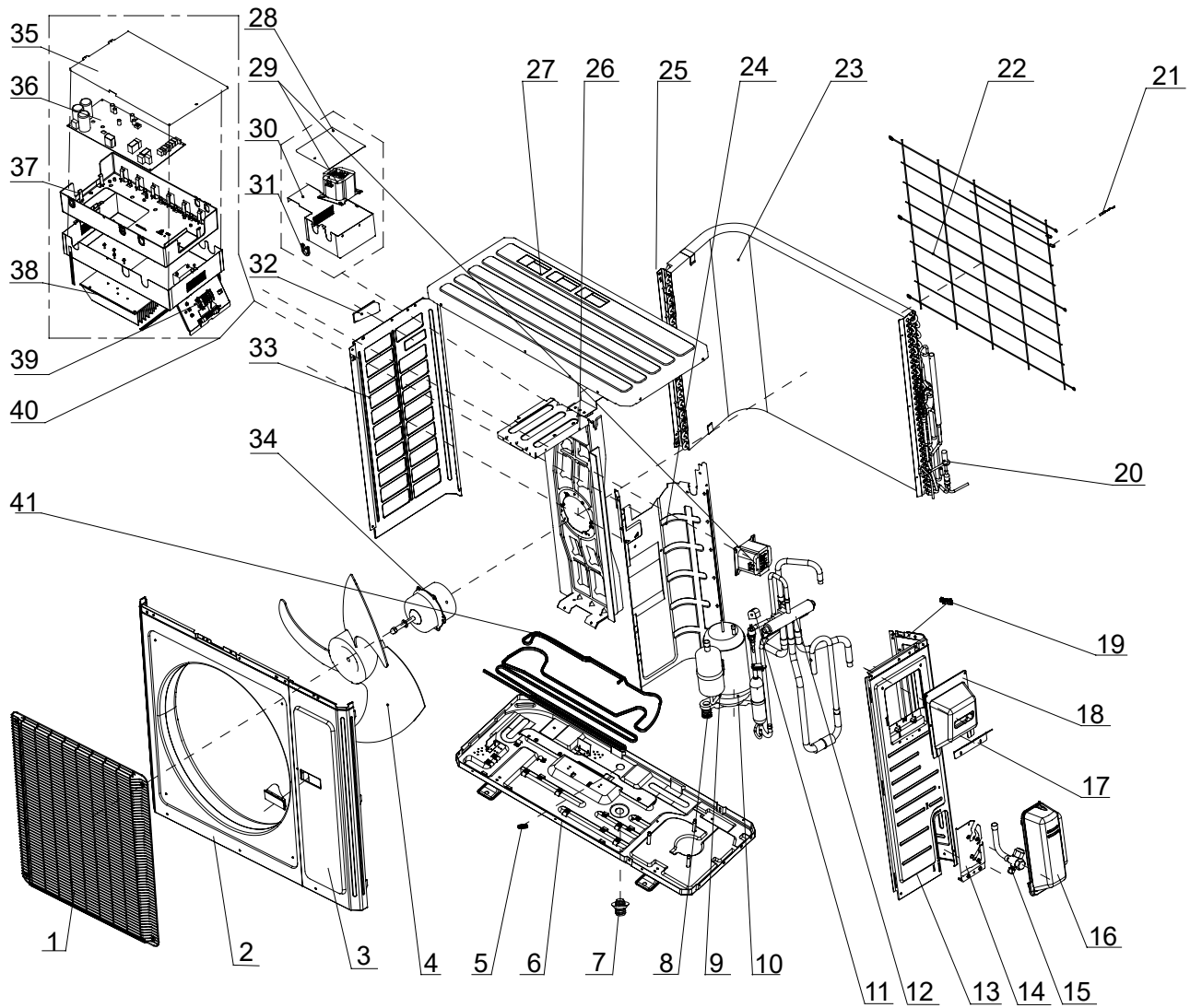

Figure 910

# PARTS CATALOG

## 36k Outdoor Unit

| Figure 910  |             |  |               |     |
|---|-------------|--|---------------|-----|
| ITEM  | PART NUMBER | PART DESCRIPTION                               | USED ON MODEL | QTY |
| 1   | 69700572    | 16004060005 - Front Grill                      | FSHSR36A3A    | 1   |
| 2   | 69700573    | 153501405 - Front Panel Assy                   | FSHSR36A3A    | 1   |
| 3   | 69700514    | 01303249P - Front Side Plate Sub-Assy          | FSHSR36A3A    | 1   |
| 4   | 69700515    | 10335014 - Axial Flow Fan                      | FSHSR36A3A    | 1   |
| 5   | #N/A        | #N/A   | FSHSR36A3A    | 1   |
| 6   | #N/A        | #N/A   | FSHSR36A3A    | 1   |
| 7   | #N/A        | #N/A   | FSHSR36A3A    | 1   |
| 8   | 69700575    | 205200003 - Compressor                         | FSHSR36A3A    | 1   |
| 9   | 69700576    | 7651873209 - Electrical Heater(Compressor)     | FSHSR36A3A    | 1   |
| 10  | 69700577    | 4300040029 - Magnet Coil                       | FSHSR36A3A    | 1   |
| 11  | 69700578    | 30152000213 - 4-Way Valve Assy/<br>REV VALVE   | FSHSR36A3A    | 1   |
| 12  | 69700522    | 0130504402P - Right Side Plate                 | FSHSR36A3A    | 1   |
| 13  | 69700579    | 0171501201P - Valve Support Sub-Assy           | FSHSR36A3A    | 1   |
| 14  | 69700524    | 7133157 - Cut off Valve                        | FSHSR36A3A    | 1   |
| 15  | 69700581    | 2115005 - Shell Handle                         | FSHSR36A3A    | 1   |
| 16  | 69700582    | 7200200001201 - Electric expand valve fitting  | FSHSR36A3A    | 1   |
| 17  | 69700583    | 3900031001 - Temperature Sensor/<br>Thermistor | FSHSR36A3A    | 1   |
| 18  | 69700528    | 1475013 - Rear Grill                           | FSHSR36A3A    | 1   |
| 19  | 69700585    | 1163491 - Condenser Assy                       | FSHSR36A3A    | 1   |
| 20  | 69700530    | 1802876 - Motor Support Sub-Assy               | FSHSR36A3A    | 1   |
| 21  | 69700587    | 51000024 - Top Cover Sub-Assy                  | FSHSR36A3A    | 1   |
| 22  | #N/A        | #N/A   | FSHSR36A3A    | 1   |
| 23  | 69700588    | 26900000008 - Cable Cross Loop                 | FSHSR36A3A    | 1   |
| 24  | #N/A        | #N/A   | FSHSR36A3A    | 1   |
| 25  | 69700533    | 01305043P - Left Side Plate                    | FSHSR36A3A    | 1   |
| 26  | 69700590    | 1570280000405 - Brushless DC Motor             | FSHSR36A3A    | 1   |
| 27  | 69700591    | 100002001028 - Electric Box Assy/<br>PCB board | FSHSR36A3A    | 1   |
| -ITEMS ARE NON- ILLUSTRATED                                       |             |  |               |     |
| *ITEMS ARE NON-STOCKED, WILL NORMALLY REQUIRE 2-3 WEEKS LEAD TIME |             |  |               |     |

# APPENDIX

## Appendix 1: Reference Sheet of Celsius and Fahrenheit

Conversion formula for Fahrenheit degree and Celsius degree:  $T_f = T_c \times 1.8 + 32$

Set temperature

| Fahrenheit display temperature (°F) | Fahrenheit (°F) | Celsius (°C) | Fahrenheit display temperature (°F) | Fahrenheit (°F) | Celsius (°C) | Fahrenheit display temperature (°F) | Fahrenheit (°F) | Celsius (°C) |
|-------------------------------------|-----------------|--------------|-------------------------------------|-----------------|--------------|-------------------------------------|-----------------|--------------|
| 61                                  | 60.8            | 16           | 69/70                               | 69.8            | 21           | 78/79                               | 78.8            | 26           |
| 62/63                               | 62.6            | 17           | 71/72                               | 71.6            | 22           | 80/81                               | 80.6            | 27           |
| 64/65                               | 64.4            | 18           | 73/74                               | 73.4            | 23           | 82/83                               | 82.4            | 28           |
| 66/67                               | 66.2            | 19           | 75/76                               | 75.2            | 24           | 84/85                               | 84.2            | 29           |
| 68                                  | 68              | 20           | 77                                  | 77              | 25           | 86                                  | 86              | 30           |

Ambient temperature

| Fahrenheit display temperature (°F) | Fahrenheit (°F) | Celsius (°C) | Fahrenheit display temperature (°F) | Fahrenheit (°F) | Celsius (°C) | Fahrenheit display temperature (°F) | Fahrenheit (°F) | Celsius (°C) |
|-------------------------------------|-----------------|--------------|-------------------------------------|-----------------|--------------|-------------------------------------|-----------------|--------------|
| 32/33                               | 32              | 0            | 55/56                               | 55.4            | 13           | 79/80                               | 78.8            | 26           |
| 34/35                               | 33.8            | 1            | 57/58                               | 57.2            | 14           | 81                                  | 80.6            | 27           |
| 36                                  | 35.6            | 2            | 59/60                               | 59              | 15           | 82/83                               | 82.4            | 28           |
| 37/38                               | 37.4            | 3            | 61/62                               | 60.8            | 16           | 84/85                               | 84.2            | 29           |
| 39/40                               | 39.2            | 4            | 63                                  | 62.6            | 17           | 86/87                               | 86              | 30           |
| 41/42                               | 41              | 5            | 64/65                               | 64.4            | 18           | 88/89                               | 87.8            | 31           |
| 43/44                               | 42.8            | 6            | 66/67                               | 66.2            | 19           | 90                                  | 89.6            | 32           |
| 45                                  | 44.6            | 7            | 68/69                               | 68              | 20           | 91/92                               | 91.4            | 33           |
| 46/47                               | 46.4            | 8            | 70/71                               | 69.8            | 21           | 93/94                               | 93.2            | 34           |
| 48/49                               | 48.2            | 9            | 72                                  | 71.6            | 22           | 95/96                               | 95              | 35           |
| 50/51                               | 50              | 10           | 73/74                               | 73.4            | 23           | 97/98                               | 96.8            | 36           |
| 52/53                               | 51.8            | 11           | 75/76                               | 75.2            | 24           | 99                                  | 98.6            | 37           |
| 54                                  | 53.6            | 12           | 77/78                               | 77              | 25           |                                     |                 |              |

## Appendix 2: Configuration of Connection Pipe

1. Standard length of connection pipe

16.40ft, 24.61ft, 26.25ft.

2. Min. length of connection pipe is 9.84ft.

3. Max. length of connection pipe and max. high difference.

4. The additional refrigerant oil and refrigerant charging required after prolonging connection pipe

After the length of connection pipe is prolonged for 32.81ft at the basis of standard length, you should add 5ml of refrigerant oil for each additional 16.40ft of connection pipe.

The calculation method of additional refrigerant charging amount (on the basis of liquid pipe):

| Cooling capacity     | Max length of connection pipe | Max height difference |
|----------------------|-------------------------------|-----------------------|
| 5000 Btu/h(1465 W)   | 49.21ft                       | 16.40ft               |
| 7000 Btu/h(2051 W)   | 49.21ft                       | 16.40ft               |
| 9000 Btu/h(2637 W)   | 49.21ft                       | 32.81ft               |
| 12000 Btu/h(3516 W)  | 65.62ft                       | 32.81ft               |
| 18000 Btu/h(5274 W)  | 80.02ft                       | 32.81ft               |
| 24000 Btu/h(7032 W)  | 80.02ft                       | 32.81ft               |
| 28000 Btu/h(8204 W)  | 98.43ft                       | 32.81ft               |
| 36000 Btu/h(10548 W) | 98.43ft                       | 65.62ft               |
| 42000 Btu/h(12306 W) | 98.43ft                       | 65.62ft               |
| 48000 Btu/h(14064 W) | 98.43ft                       | 65.62ft               |

When the length of connection pipe is above 16.40ft, add refrigerant according to the prolonged length of liquid pipe. The additional refrigerant charging amount per meter is different according to the diameter of liquid pipe. See the following sheet.

Additional refrigerant charging amount = prolonged length of liquid pipe X additional refrigerant charging amount per meter

| Additional refrigerant charging amount for R22, R407C, R410A and R134a |                |                       |                              |
|--|----------------|-----------------------|------------------------------|
| Diameter of connection pipe  |                | Outdoor unit throttle |                              |
| Liquid pipe(inch)  | Gas pipe(inch) | Cooling only(oz./ft.) | Cooling and heating(oz./ft.) |
| Φ1/4   | Φ3/8 or Φ1/2   | 0.2                   | 0.2                          |
| Φ1/4 or Φ3/8   | Φ5/8 or Φ3/4   | 0.2                   | 0.2                          |
| Φ1/2   | Φ3/4 or Φ7/8   | 0.3                   | 1.3                          |
| Φ5/8   | Φ1 or Φ1 1/4   | 0.7                   | 1.3                          |
| Φ3/4   | /              | 2.7                   | 2.7                          |
| Φ7/8   | /              | 3.8                   | 3.8                          |

# APPENDIX

## Appendix 3: Pipe Expanding Method

**⚠ Note:**

**Improper pipe expanding is the main cause of refrigerant leakage. Please expand the pipe according to the following steps:**

**A: Cut the pipe**

Confirm the pipe length according to the distance of indoor unit and outdoor unit.  
Cut the required pipe with pipe cutter.

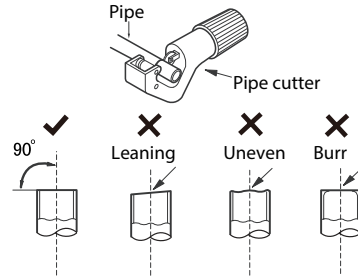

**B: Remove the burrs**

Remove the burrs with shaper and prevent the burrs from getting into the pipe.

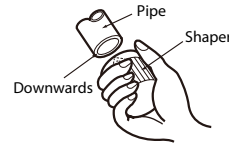

**C: Put on suitable insulating pipe**

**D: Put on the union nut**

Remove the union nut on the indoor connection pipe and outdoor valve; install the union nut on the pipe.

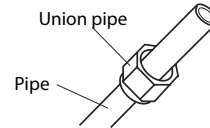

**E: Expand the port**

Expand the port with expander.

**⚠ Note:**

"A" is different according to the diameter, please refer to the sheet below:

| Outer diameter(inch) | A(inch) |      |
|----------------------|---------|------|
|                      | Max     | Min  |
| Φ1/4                 | 2/39    | 1/36 |
| Φ3/8                 | 1/16    | 1/51 |
| Φ1/2                 | 1/14    | 1/51 |
| Φ5/8                 | 5/53    | 2/23 |

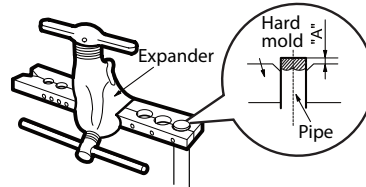

**F: Inspection**

Check the quality of expanding port. If there is any blemish, expand the port again according to the steps above.

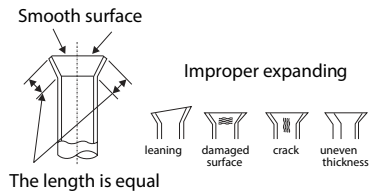



Friedrich Air Conditioning Company  
10001 Reunion Place, Suite 500  
San Antonio, TX 78216  
800-541-6645  
[www.friedrich.com](http://www.friedrich.com)

## FLOATING AIR DUCTLESS SPLIT SYSTEMS

### LIMITED WARRANTY

1. **A) FIVE YEAR WARRANTY - FRIEDRICH AIR CONDITIONING CO. (FRIEDRICH)** warrants to the original end-user of this product that should it prove defective due to improper workmanship and/or material under normal use for a period of five years from the date of installation, FRIEDRICH will repair or replace, at its option, any defective part without charge for the part. Replacement parts are warranted for the remainder of the original warranty period.
- B) THIS WARRANTY DOES NOT INCLUDE LABOR** or other cost incurred for servicing, repairing, removing, installing, shipping, or handling of either defective or replacement parts, or complete unit. Such cost may be covered by a separate warranty provided by the installing contractor.
- C) FIVE YEAR COMPRESSOR WARRANTY-** During the five year warranty period from the date of installation, should the compressor prove defective due to improper workmanship and/or material, **FRIEDRICH** will furnish a replacement compressor, at no charge, which is warranted for the remainder of the original warranty period. **LABOR IS NOT INCLUDED FOR INSTALLING REPLACEMENT COMPRESSOR.**  
**These warranties apply only while the unit remains at the original site and only to units installed inside the continental United States, Alaska, Hawaii, Puerto Rico, Mexico and Canada. The warranty applies only if the unit is installed and operated in accordance with the printed instructions and in compliance with applicable local installation and building codes and good trade practices. For international warranty information, contact the Friedrich Air Conditioning Company - International Division.**
- D) NOTICE: To obtain service and/or warranty parts replacement, you must notify an authorized FRIEDRICH Air Conditioning Co. distributor, dealer, or contractor of any defect within the applicable warranty period.
2. Any defective part to be replaced must be made available to **FRIEDRICH** in exchange for the replacement part. You must present proof of the original date of installation of the product in order to establish the effective date of the warranty. Otherwise, the effective date will be deemed to be the date of manufacture plus thirty days. The return of the owner registration card is not a condition of warranty coverage. However, please detach and return it so that we can contact you should a question of safety arise which could affect you.
3. **TO OBTAIN WARRANTY SERVICE**, please contact your authorized **FRIEDRICH** distributor, dealer, or the contractor who installed the equipment. If your dealer or contractor needs assistance, the authorized **FRIEDRICH** distributor is available for consultation, and **FRIEDRICH** supports the efforts of the distributor.
4. This limited warranty applies only to units remaining at the site of the original installation (except for mobile home installations) and only to units installed within the continental United States, Alaska, Hawaii, and Canada. This limited warranty applies only if the unit is installed and operated in accordance with FRIEDRICH instructions and in compliance with applicable local installation and building codes and good trade practices.
5. **THIS WARRANTY DOES NOT COVER** damages caused by: (a) accident, abuse, negligence, or misuse; (b) operating the product in a corrosive atmosphere containing chlorine, fluorine or any other damaging chemicals; (c) modification, alteration, poor service practices; (d) improper matching or application of the product or components; (e) failure to provide proper maintenance and service to the product according to manufacture's instructions; (f) installation or operating of the product in a manner contrary to the instructions of the manufacturer; (g) lightning, fluctuations in electrical power or other Acts of God. This LIMITED WARRANTY also excludes all cost of installation, disconnection or dismantling the product, parts used in connection with normal maintenance such as air filters or belts and owner-required maintenance. Consult the instructions enclosed with the product for information regarding recommended maintenance.
6. No one is authorized to change this **LIMITED WARRANTY** in any respect, or to create any other obligation or liability in connection with this product.
7. **YOUR ONLY REMEDIES ARE PROVIDED IN THIS LIMITED WARRANTY. ANY EXPRESS WARRANTY NOT PROVIDED HEREIN, AND ANY REMEDY WHICH, BUT FOR THIS PROVISION, MIGHT ARISE BY IMPLICATION OR OPERATION OF LAW, IS HEREBY EXCLUDED AND DISCLAIMED. THE IMPLIED WARRANTIES OF MERCHANTABILITY AND OF FITNESS FOR ANY PARTICULAR PURPOSE ARE EXPRESSLY LIMITED TO A TERM OF ONE YEAR FROM THE DATE OF ORIGINAL INSTALLATION. UNDER NO CIRCUMSTANCES SHALL FRIEDRICH BE LIABLE TO THE OWNER OR ANY OTHER PERSON FOR ANY INCIDENTAL, SPECIAL OR CONSEQUENTIAL DAMAGES IN CONNECTION WITH THIS PRODUCT, WHETHER ARISING OUT OF BREACH OF WARRANTY, BREACH OF CONTRACT OR OTHERWISE.**
8. Some states do not allow limitations on how long an implied warranty lasts and/or do not allow the exclusion or limitation of incidental, special or consequential damages, so the above limitations or exclusions may not apply to you.
9. This warranty gives you specific legal rights, and you may have other rights which vary from state to state and province to province.

---

## CUSTOMER SATISFACTION and QUALITY ASSURANCE

Friedrich is a conscientious manufacturer, concerned about customer satisfaction, product quality, and controlling warranty costs. As an Authorized Service Provider you play a vital role in these areas. By adhering to the policies and procedures you provide us with vital information on each warranty repair you complete. This information is used to identify product failure trends, initiate corrective action, and improve product quality, thereby further reducing warranty expenses while increasing customer satisfaction levels.

### FRIEDRICH AUTHORIZED PARTS DEPOTS

**AAA Refrigeration Service**

1322 24th Street, Suite B Kenner,  
Louisiana 70062 504-464-7444  
877-813-7444

**Alamo Service Company**

1450 North Flores Street San  
Antonio, Texas 78212 210-227-  
2450  
800-328-2450

**The Gabbert Company**

6868 Ardmore  
Houston, Texas 77054

713-747-4110

800-458-4110

**Johnstone Supply of Woodside**

27-01 Brooklyn Queens Expway  
Woodside, New York 11377 718-  
545-5464  
800-431-1143

**Reeve Air Conditioning, Inc.**

2501 South Park Road Hallandale, Florida  
33009 954-962-0252  
800-962-3383



# FRIEDRICH

## TECHNICAL SUPPORT CONTACT INFORMATION

Friedrich Air Conditioning Co.  
10001 Reunion Place, Suite 500 • San Antonio, Texas 78216  
1-800-541-6645  
[www.friedrich.com](http://www.friedrich.com)