

Frigidaire

Factory Parts Catalog

Product No.	FWS1233FS1
Series	Frigidaire
Market	North America
Color	white
Volts	120
Wiring Diagram	134755300
Owner's Guide	134752500
Installation Instructions	134752400
Operating Instructions	134752900
Energy Guide	134757000



Electrolux Major Appliances
North & Latin America
P.O. BOX 212378
AUGUSTA, GA 30917

Publication No.
5995492856
07/06/14
(EN/SERVICE/WTC)
361

**TOP-LOAD WASHING
MACHINE**

Model No.
FWS1233F

Copyright © 2007 Electrolux Home Products, Inc.
All rights reserved.

CABINET/TOP

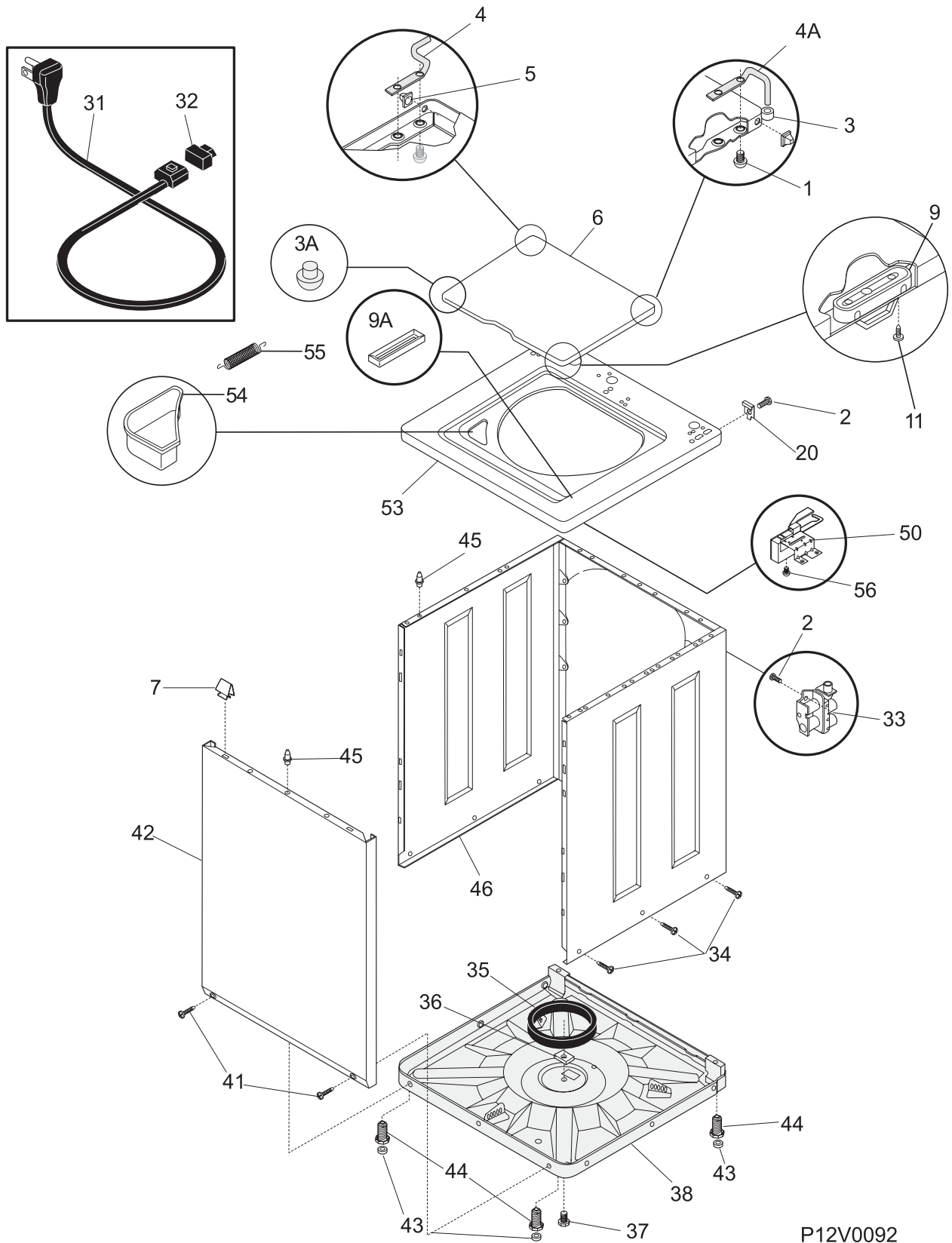

P12V0092

CABINET/TOP

POS. NO	PART NO.	DESCRIPTION
1	134203900	Screw, pan hd phillips, 6-32 x 0.337, dog point
2	131168200	Screw, pan head, 8-18B x 0.31
3	131433300	Bumper, lid hinge
3A	134075500	Bumper, lid, front
4	131385910	Hinge Bar, LH
4A	131374220	Hinge Bar, RH
5	5303208743	Grommet, hinge
6	131374401	Lid, white
7	3205821	Clip, top-to-front
9	131390000	Lid Strike
9A	134768500	Insert, striker plate, lid slot
11	3204368	Screw, lid strike mtg, 6-20B X 0.375
20	5303208751	Hinge, top panel, cabinet rear
31 #	134501000	Power Cord, electric svce
32	5303209428	Bushing, power cord
33 #	134890600	Valve, water, 115 V
34	131205500	Screw, cab body, 1/4-14 x 0.625, side-to-base
35	5308002385	Snubber Ring
36	3204380	Shipping Block
37	131658900	Screw, shipping, 1/4-20 x 1.001, yellow, unit base, thread forming
38	134773500	Base Assembly
41	131258400	Screw, 10-16AB x 0.500
42	131104303	Panel, front, white
43	131422100	Pad, leveling leg
44	5303309673	Screw, leveling leg, with pad
45	131346400	Pin, panel locator
46	134046600	Cabinet Assy, white, back and sides
50 #	134101800	Lock, lid, w/ext switch
53	131452692	Panel, white, top
54	5303208778	Dispenser, bleach
55	134890500	Spring, lid assist
56	131243700	Screw, pan head, 8-18AB x 0.375

MOTOR/TUB

POS. NO	PART NO.	DESCRIPTION
3	131551103	Cover, splash tub, with seal
3*	131901400	• Seal, splash cover
4 #	131212301	Capacitor, motor
6	5303271009	Hose, inlet, 48 inch long
7	5303161296	Washer, inlet hose
9	5303304824	Clamp
10	134211700	Hose Assy, w/nozzle
11 #	131605901	Agitator Assy, dual action
12	131221300	Tub, spin
13	5303283293	Screw, trunion, 5/16-18 x 0.625, (5)
14	131192800	Screw, lockplate, 5/16-18 x 1.625
15	5308001923	Plate, lock
16	131545101	Trunnion
18	131557201	Tub, splash, w/air dome, brg
19	131205300	Screw, 10-16 x 0.750
20	3205150	Screw, tub bearing, 8-12B x 0.750
21	5308002401	Washer, spin bearing, upper
22	131373610	Leg & Dome Assy
23	134886600	Spring, vertical, short
23*	5303212877	Insert, spring adjuster, vertical
23A	134885900	Spring, vertical
24	131373900	Spring, horizontal
26 #	3204405	Bearing, outer tub
27	5303304825	Screw, set, hex hd cup, 5/16-18 x 0.85, xmsn pulley, hex head cup pt
28 #	134511600	V-Belt, washer drive, standard 4L
29 #	131498301	Pulley, xmsn drive
30 #	131862900	Idler Arm Assy, VAW, with pulley
33	3204425	Spring, torsional
34	3204426	Sleeve, idler pivot
35	3161433	Ring, retaining
36	5303261031	Washer, pivot shaft
37	5303161306	Washer, spring type
38	5303318708	Nut, hex flange, motor mounting
40 #	134159500	Motor, 3/4 hp, 2 speed, with pulley
41	131513300	• Shield, motor assy, w/speed nuts
41	5303283052	• Speed Nut, motor shield, steel clip
41 #	131715800	Shield, motor assy, w/capacitor, nut
43 #	134740500	Pump, drain
45 #	134592700	Hose, drain
45*	131453000	Bushing, snap-in
45*	131663500	Cushion, drain hose, base
45*	134261300	Clip, drain hose, push-mount
45*	134745300	Clip, drain hose
48	131306234	Clamp, hose, wire
49 #	131494800	Hose, pump to tub
51	134164400	Screw, hex washer head, 5/16-18 x 0.625
53	5300771996	Tube, pressure, vinyl
56	131468900	Screw, agitator mtg, 5/16-18 x 1.250
57	131339600	Spacer, agitator mtg, rubber
58	134160900	Screw, washer hd, 10-16AB X 0.75
62	131258400	Screw, 10-16AB x 0.500
66	131624500	Agitator Cap Assy, dispenser cup, dual action
67	131606210	Mechanism, disp cap assy, dual action
68	131707800	Ring, drain hose
68*	5303309503	Clip, drain hose, back sheet

TRANSMISSION

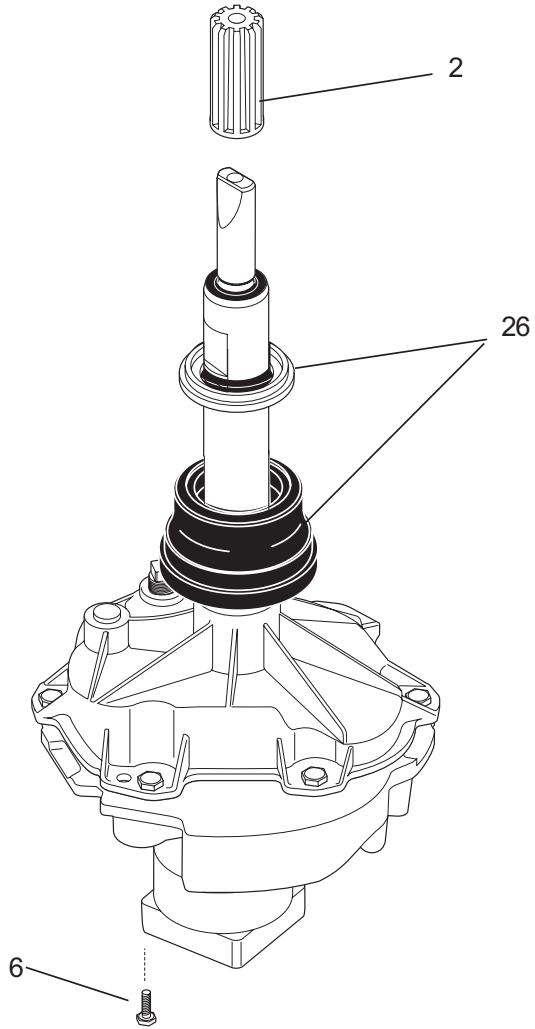
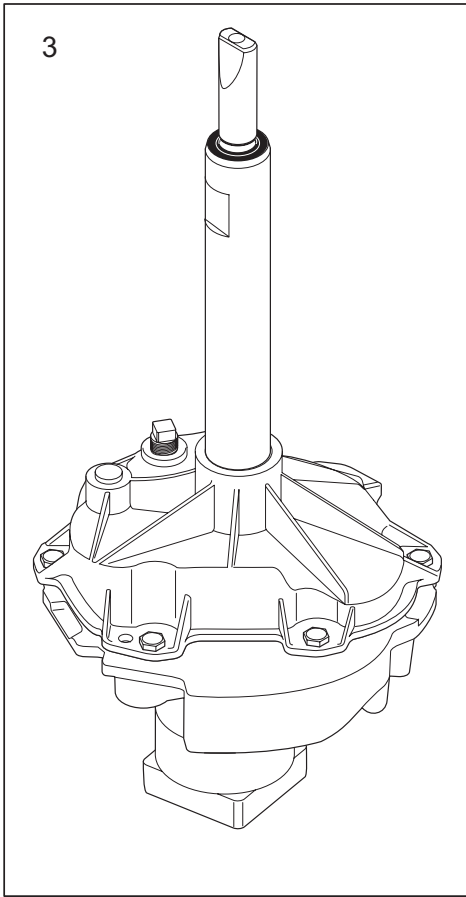

P12M0014

TRANSMISSION

POS. NO	PART NO.	DESCRIPTION
2 #	134418700	Hub, drive, agitator
3 #	134737100	Transmission, service kit
6	134197900	Screw, hex washer head, 1/4-20 x 0.437
26 #	5303279394	Seal Assy, tub, transmission

CONTROL/PANEL

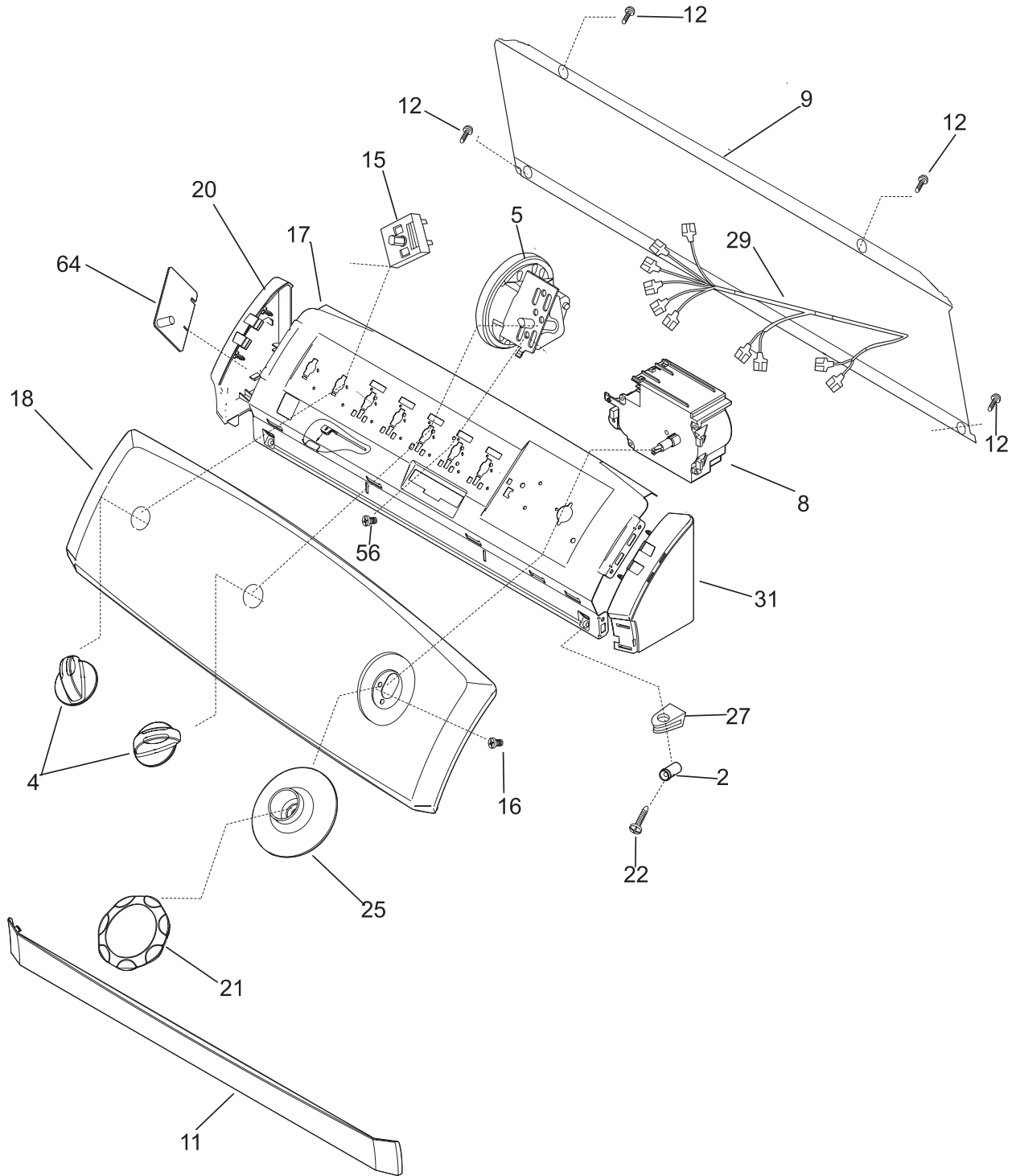

P12C0374

CONTROL/PANEL

POS. NO	PART NO.	DESCRIPTION
2	134096100	Spacer, console mtg
4	134034910	Knob, rotary, white
5	134411600	Switch, pressure, 3 position
8 #	134049600	Timer, washer
9	131992910	Panel, backsheet, console
11	134019900	Closure, console trim, white, front
12	131168200	Screw, pan head, 8-18B x 0.31
15 #	134403500	Switch, temp selector, 3 position
16	131477001	Screw, pan head, 10-16AB x 0.375
17	131993040	Bracket, control mtg.
18	134071700	Trimplate FDA1SRSZ
20	134019610	End Cap, white, LH
21	134035200	Knob, timer, white, assy
22	131266330	Screw, 8-18 x 1.250
25	134035100	Pointer, timer knob, white, dark gray ind
27	131197000	Clip, console mtg
29 #	134895300	Wiring Harness
31	134019600	End Cap, white, RH
56	131243800	Screw, pan hd locking, 8-32CA x 0.375, cup point
64 #	134810610	Control Board, temperature, ATC
*	134757000	Energy Guide

WIRING DIAGRAM

CAUTION: DISCONNECT ELECTRIC CURRENT BEFORE SERVICING

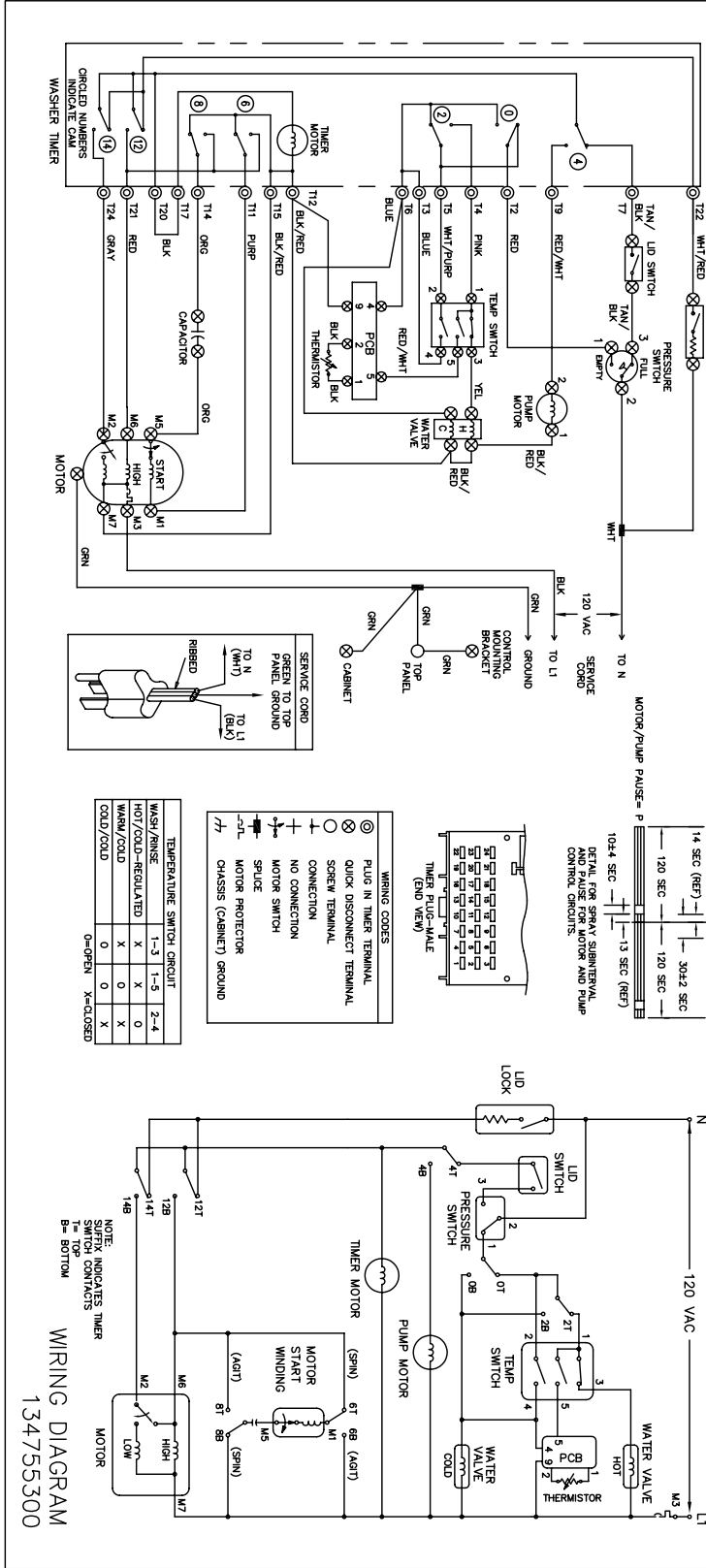
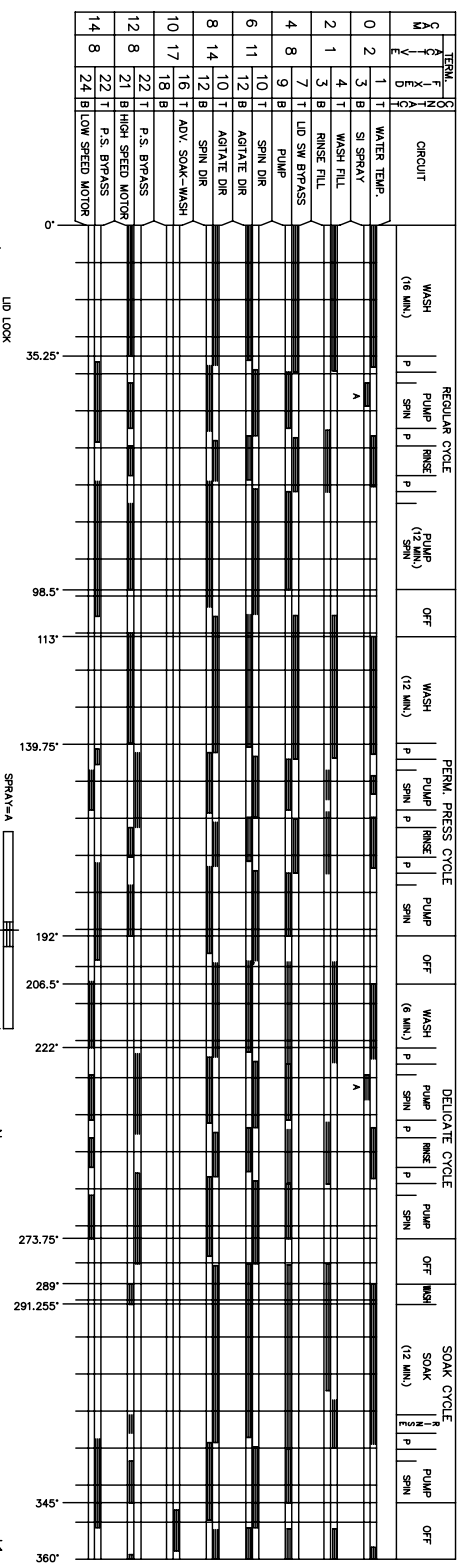

WIRING DIAGRAM 134755300

WIRING DIAGRAM

ATTENTION: COUPER L'ALIMENTATION ÉLECTRIQUE AVANT DE DÉPANNER L'APPAREIL

