

FTU171X7

36", Stainless Steel French-Door Refrigerator
with Automatic Freezer

EAN13: 8017709226770

Standard hinge

Fingerprint-proof

Display: LCD

Display functions: fast freezing, fast cooling,
temperature

Ice & water dispenser

Refrigerator compartment features:

Glass adjustable shelves

Crisper compartment

LED refrigerator internal lighting

Refrigerator inner door:

2 balcony with transparent cover

3 adjustable balconies

2 bottle balconies

1 egg tray

Natural Plus light

Freezer compartment features:

2 drawers

Other freezer features:

Fast-freezing compartment

Performance/energy label:

Annual energy consumption: 681 kWh

Fresh food compartment net volume: 18,4 cu. ft.

Freezer compartment net volume: 7,7 cu. ft.

Frozen food compartment star rating: 4

Frost-free system

Climatic class: T

Noise level: 43dB(A)

Electrical connection:

Voltage: 120V

Frequency (Hz): 60Hz

Plug type: USA

Dimensions:

HxWxD 1774x980x1239 mm

69" 13/16 x 36" x 32" 1/2



Functions



**SMEG U.S.A. INC.
A&D BUILDING
150 EAST 58th STREET, 7th FLOOR
NEW YORK, NY, 10155
Tel. +1 212 265 5378
Fax +1 212 265 5945**



FTU171X7

fridge
free standing
french door
stainless steel
36"



Energy Star and ISO14001 Certified:

The Smeg production process is carefully managed in order to keep the impact upon the environment as low as possible. The process is checked and certified by Independent International bodies IQNET and CISQ (Smeg complies with the standard ISO14001). All Smeg dishwashers are ENERGY STAR qualified. Energy efficiency is important to Smeg and our technicians are constantly working to keep the energy, and water, consumption of each dishwasher as low as possible. ENERGY STAR certified products use less water than conventional dishwashers, and approximately 40% less energy than the federal minimum standard for energy consumption. By choosing an ENERGY STAR certified product you are helping to preserve the environment without compromising on product quality or performance.



SMEG U.S.A. INC.
A&D BUILDING
150 EAST 58th STREET, 7th FLOOR
NEW YORK, NY, 10155
Tel. +1 212 265 5378
Fax +1 212 265 5945



FTU171X7

fridge
free standing
french door
stainless steel
36"

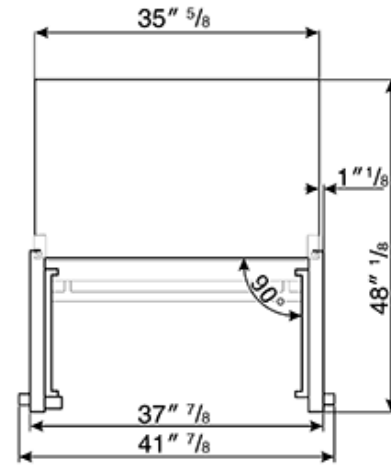
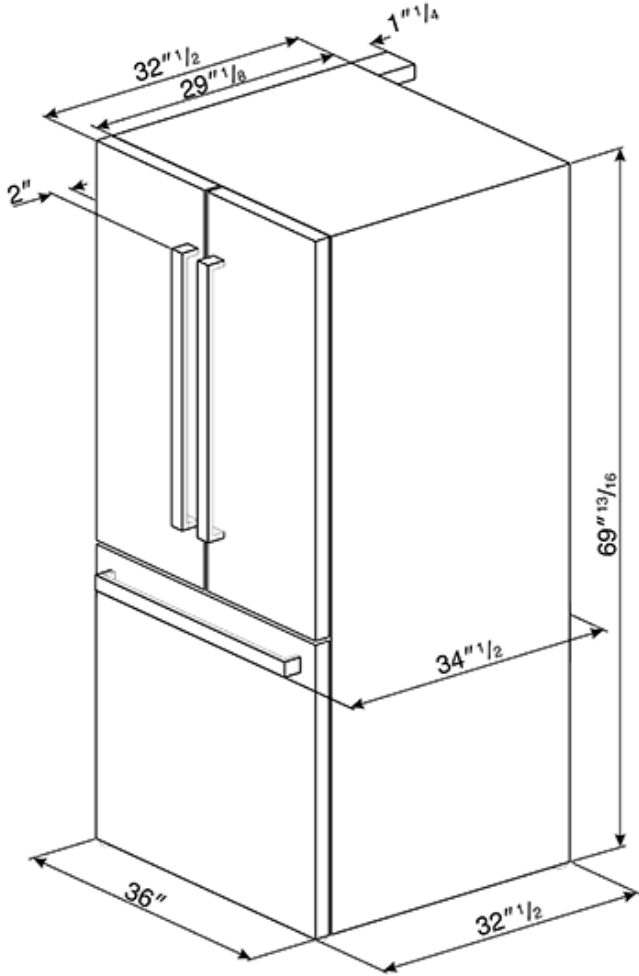

SMEG U.S.A. INC.
A&D BUILDING
150 EAST 58th STREET, 7th FLOOR
NEW YORK, NY, 10155
Tel. +1 212 265 5378
Fax +1 212 265 5945