

**FS24L**

19.63" x 18.5" x 17.63" (H x W x D)

Compact all-freezer for general purpose use, manual defrost with lock

**Highlights:**

- Compact "cube" size is ideal for use on top of counters
- Factory installed lock provides security you can count on
- Designed for general purpose use in medical and scientific facilities
- Reversible door offers flexible placement



**AjMadison**  
Your Appliance Authority  
800-570-3355

Compact size	Convenient "cube" shape is ideal for use on top of counters
Factory installed lock	Keyed lock for a secure interior
Manual defrost	Static cooling system
One-piece interior liner	Seamless interior for easier cleanup
Removable shelf	Includes one wire shelf for easier storage
Reversible door	User reversible door swing for added flexibility
Adjustable thermostat	Dial thermostat for easy temperature management
Flat door liner	Designed to comply with CDC guidelines
100% CFC Free	Environmentally friendly design with no ozone-damaging chemicals

## Specifications:

Height	19.63"
Width	18.5"
Depth	17.63"
Capacity	1.4 cu.ft.
Interior Height 1	14.38"
Interior Width 1	13.5"
Interior Depth 1	13.25"
Comp Step Height	8.5"
Comp Step Width	13.5"
Comp Step Depth	6.0"
Shipping Weight	55.0 lbs.
Weight	31.0 lbs.
US Electrical Safety	ETL
Voltage/Frequency	115 V AC/60 Hz
Canadian Electrical Safety	ETL-C
Amps	0.8
Reversible	Yes
Door Swing	RHD
Shelf Quantity	1
Shelf Type	Wire
Defrost Type	Manual
Height to Hinge Cap	20.0"
Depth with door at 90°	34.5"
Thermostat Type	Dial
Condensor Location	N/A
Level Legs Quantity	2
Refrigerant Type	R134a
Freon Oz	1.5
Compressor Warranty	5 Years
Parts/Labor Warranty	1 Year

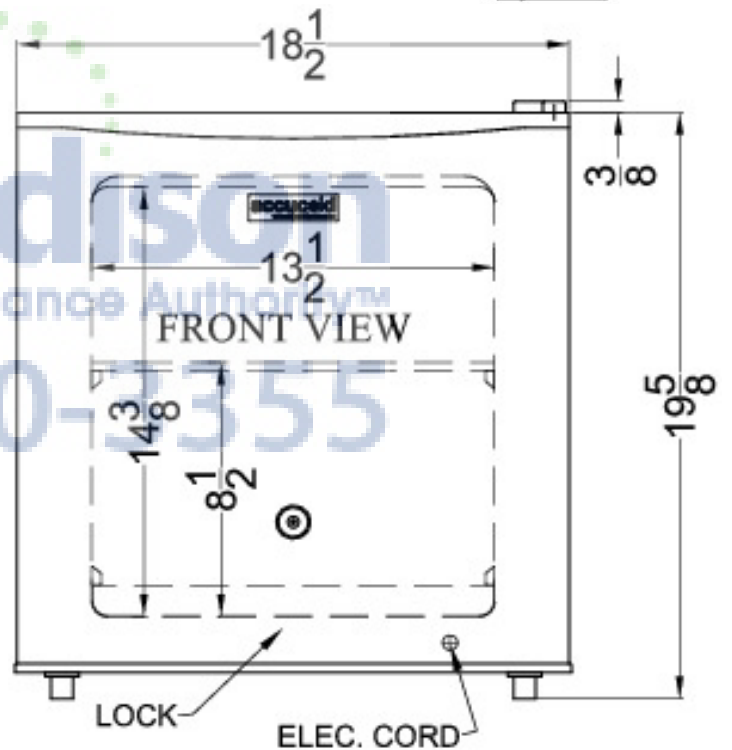
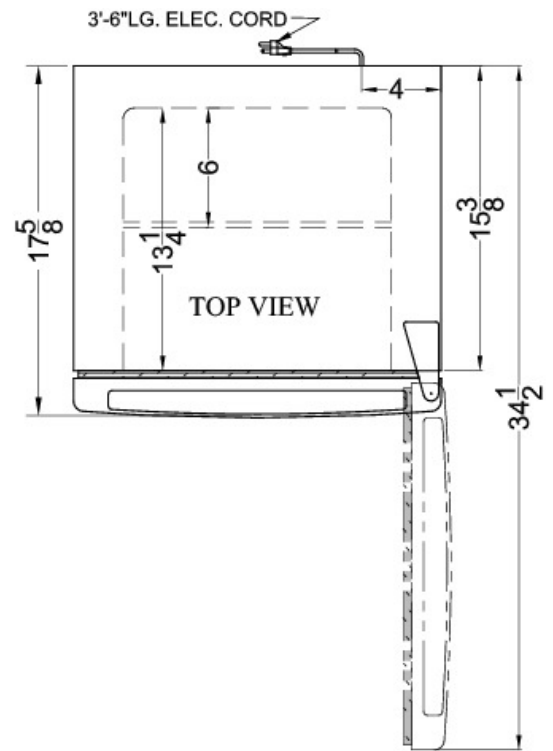

**AjMadison**  
Your Appliance Authority™  
800-570-3355

Summit Appliances Division, Felix Storch, Inc.  
770 Garrison Ave • Bronx, NY 10474  
Phone: 718-893-3900 • Fax: 718-842-3093  
Email: info@summitappliance.com