

▶ IMPORTANT SAFETY NOTE

The information provided herein is designed to assist qualified repair personnel only. Untrained persons should not attempt to make repairs due to the possibility of electrical shock. Disconnect power cord before servicing this appliance.

IMPORTANT

If any green/yellow grounding wires are removed during servicing, they must be returned to their original position and properly secured.

PERFORMANCE AT FACTORY SETTING

Ambient Temperature	70°F	90°F
Operating Time	100%	
Freezer Temperature	4 to -4°F	
Low Side Pressure (Cut-in)	--	
Low Side Pressure (Cut-off)	-9.8 to -4.4 psig	-7.8 to -4.4 psig
High Side Pressure	35 to 47 psig	51 to 56 psig
Wattage	35W	54W
Amps	0.50	0.68
Base Voltage	115	
Refrigerant Charge	50g	
Defrost Heater	206W	

DEFROST SPECIFICATIONS

Cabinet Size: 19'	Thermal Cutout		Heater	
	Open	Closed	Watts	Ohms
	n/a		206	n/a

Specifications subject to change without notice. For complete performance data by model, refer to service manual. Options shown are not necessarily part of model.

DEFROST CONTROL

The defrost period will vary dependent on the heater on time, with a maximum of 60 minutes. There is a 5 minute idle (drip time) time after the heater turns off before the evaporator fan and compressor will turn on. During the defrosting period a temperature sensor monitors the evaporator temperature and the main control board turns the defrost heater off after the frost on the evaporator has melted.

A manual defrost can be activated by simultaneously pressing and holding **+** and **AIR FILTER** for 10 seconds. The temperature display will show **dF** for a few seconds indicating manual defrost is activated and a beep will be heard. Then the unit will display the last set point. There may be up to a 3 minute delay before the defrost heater is energized.

ICE MAKER INFORMATION

Adjust Water Fill Setting: Press and hold **FREEZER BOOST** and **ICE MAKER** together for 10 seconds. Use **+** and **-** to select water fill setting. Display switches back to normal mode in 10 seconds.

SERVICE DATA SHEET

A16331302

AUTOMATIC DEFROST UPRIGHT FREEZER - R600A

▶ **IMPORTANT: PLEASE RETURN THIS SHEET TO ITS ORIGINAL LOCATION.**

SERVICE MODE DIAGNOSTIC TESTS

Allows technicians to step through available tests to diagnose individual electrical circuits.

To Enter and Exit Service Mode: Press and hold **-** and **+** simultaneously for 10 secs

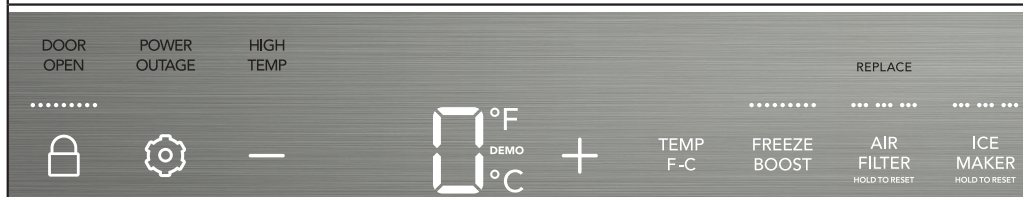

Controls:

Upon entering Service Mode the User Interface illumination test begins.

- All of the LEDs on the User Interface will illuminate.
- Press and release **+** and all of the LEDs on the User Interface will turn off.
- Press and release **+** to move to the Output Loads test. Press and release **FREEZE BOOST** to energize load.
- Pressing and releasing **+** moves through the Output Loads test, input tests and information display phase. Press and release **-** to go back to previous tests.
- The table provides the test description, test number that is displayed to identify the specific test being performed and the displayed info when the test output or input is activated.

Software Code Streaming

During this phase all software parameters and codes which are programmed into the Main Control Board and User Interface board will be displayed in the following order:

- Main Control Board parameters code (8 characters)
- Main Control Board software name code (8 characters)
- User Interface software name code (8 characters)

The User Interface displays each character for 1 second, and then the buzzer emits a short beep and displays the next character.

- Between the 3 different sets of code displays, the User Interface displays a horizontal bar.
- Pressing and releasing **+** before the software streaming phase is completed the Service Mode goes straight to the lifetime information display phase.
- After the software code streaming phase is complete the test automatically goes to the lifetime streaming phase.

Lifetime Display

During this phase the display shows the total number of days the appliance has been powered up.

- Each number is shown on the display starting from the most significant one. Pressing and releasing **+** makes the buzzer emit a short beep and then display the next digit.
- Pressing and releasing **+** when the fourth digit is displayed makes the Service Mode go straight to the final phase.

Final Phase

During this phase the User Interface shows a 1-sec upcounting timer. This phase communicates Service Mode has come to an end. To return to normal mode, press and hold **-** and **+** simultaneously for 10 secs.

120 VAC OUTPUT LOAD TESTS

	Test Number	Load	Display
Defrost Heater	2	120 VAC, ≈206 W	oF (OFF)/ on (ON)
Condenser Fan	12	120 VAC, ≈3.1 W	
Primary Water Valve	56	120 VAC, ≈15 W	

DIGITAL OUTPUT TESTS

	Test Number	Load	Display
DC Evaporator Fan	15	+12 VDC, ≈1 W	oF (OFF) Π (MID SPEED) on (FULL SPEED)
Freezer LED Lights	20	+12 VDC, ≈21.6 W Total	oF (OFF)/ on (ON)
Compressor Inverter Speed Control	38	12 V Square Wave	
Ice Maker Fan	62	+12 VDC, ≈2.5 W	
Fill Tube Heater	67	+12 VDC, ≈0.9 W	
Ice Maker Filtered Water Fill Output	81	+12 VDC	

TWIST TRAY ICE MAKER TESTS

This phase is to test the ice maker twist tray motor and bail arm. When this mode is entered the twist tray motor moves to the home position. Pressing and releasing **ICE MAKER** makes the twist tray cycle (flashes I while cycling). Pressing and releasing **ICE MAKER** again makes the bail arm cycle, checking if the ice bucket is empty or full.

	Test Number	Display
Twist Tray Motor	50	GO (HOME)/I (FLASHING)/ GO (CYCLE COMPLETED)
Bail Arm	78	EΠ (EMPTY)/ I (FLASHING)/ EΠ (EMPTY) or FU (FULL)

DIGITAL INPUT TESTS

	Test Number	Display
Freezer Magnetic Door Switch	24	OP (OPEN)/CL (CLOSED)

TEMPERATURE SENSOR TESTS

	Test Number	Display
Freezer Cabinet Temp Sensor	30	OP (OPEN)/SH (SHORT)
Main Board Ambient Temp Sensor	33	
Evaporator Defrost Temp Sensor	39	
Ice Maker Twist Tray Temp Sensor	45	

ERROR CODES

Error Type	Digit Display
Communication error (communication was never achieved at power up or lost communication between main board and UI board during normal system run)	CE
Freezer Cabinet NTC	T1
Freezer Defrost NTC	T2
Freezer Icemaker NTC	T6

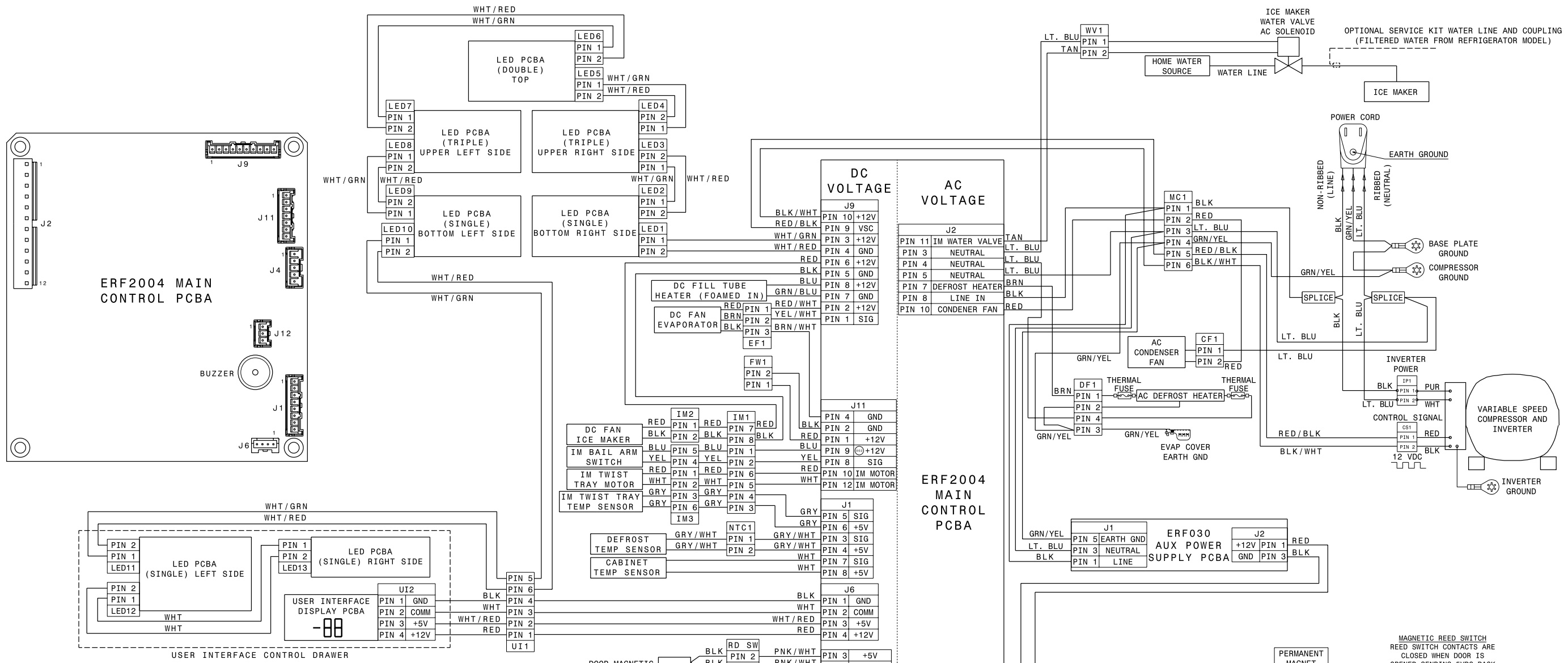

ABBR.	EXPLANATION
MC1	6 PIN (2x3) INLINE CONNECTION TO HARNESS FROM MAIN CONTROL PCBA HOUSING (IN MACHINE COMPARTMENT)
CF1	2 PIN (1x2) CONNECTION TO AC CONDENSER FAN (IN MACHINE COMPARTMENT)
IP1	2 PIN (1x2) IN LINE CONNECTION TO INVERTER POWER CONNECTOR (IN MACHINE COMPARTMENT)
CS1	2 PIN (1x2) IN LINE CONNECTION TO INVERTER CONTROL SIGNAL CONNECTOR (IN MACHINE COMPARTMENT)
DF1	4 PIN (1x4) CONNECTION TO DEFROST HEATER (BEHIND EVAPORATOR COVER)
EF1	3 PIN (1x3) CONNECTION TO DC EVAPORATOR FAN (BEHIND EVAPORATOR COVER)
NTC1	4 PIN (1x4) CONNECTION TO DEFROST TEMP SENSOR (BEHIND EVAPORATOR COVER)
UI1	6 PIN (1x6) INLINE CONNECTION FOR USER INTERFACE AND LED LIGHTS (LOCATED LEFT SIDE OF UI CONTROL DRAWER)
UI2	4 PIN (1x4) CONNECTION TO USER INTERFACE (INSIDE USER INTERFACE CONTROL DRAWER ASSEMBLY)
RD SW	2 PIN (1x2) INLINE CONNECTION FOR USER INTERFACE (LOCATED IN THE TOP FRONT OF THE CABINET)
J9	10 PIN (1x10) CONNECTION TO DC OUTPUTS ON MAIN CONTROL BOARD (LOCATED IN PLASTIC HOUSING ON BACK OF UNIT)
J1	8 PIN (1x8) CONNECTION TO DC INPUTS ON MAIN CONTROL BOARD (LOCATED IN PLASTIC HOUSING ON BACK OF UNIT)
J11	12 PIN (2x6) CONNECTION TO DC OUTPUTS ON MAIN CONTROL BOARD (LOCATED IN PLASTIC HOUSING ON BACK OF UNIT)
J6	4 PIN (1x4) CONNECTION TO MAIN CONTROL PCBA USER INTERFACE FUNCTION (LOCATED IN PLASTIC HOUSING ON BACK OF UNIT)
J2	12 PIN (1x12) CONNECTION TO AC INPUTS/OUTPUTS ON MAIN CONTROL BOARD (LOCATED IN PLASTIC HOUSING ON BACK OF UNIT)
J12	3 PIN (1x3) CONNECTION TO +12VDC DC INPUT ON MAIN CONTROL BOARD (LOCATED IN PLASTIC HOUSING ON BACK OF UNIT)
J4	5 PIN (1x5) CONNECTION TO MAIN CONTROL BOARD, DOOR MAGNETIC REED SWITCH FUNCTION (LOCATED IN PLASTIC HOUSING ON BACK OF UNIT)
J2	3 PIN (1x3) CONNECTION TO +12VDC DC OUTPUT ON AUXILIARY POWER SUPPLY BOARD (LOCATED IN PLASTIC HOUSING OVER COMPRESSOR)
J1	5 PIN (1x5) CONNECTION TO AC INPUT POWER ON AUXILIARY POWER SUPPLY BOARD (LOCATED IN PLASTIC HOUSING OVER COMPRESSOR)
WV1	2 PIN (1x2) CONNECTION TO AC WATER VALVE SOLENOID (LOCATED BEHIND REAR ACCESS COVER TO THE RIGHT OF THE MAIN BOARD COVER)
FW1	2 PIN (1x2) CONNECTION TO DC OUTPUT TO REFRIGERATOR FOR FILTERED WATER TO ICEMAKER SERVICE KIT (LOCATED BEHIND REAR ACCESS COVER TO THE RIGHT OF THE MAIN BOARD COVER)
IM1	8 PIN (1x8) INLINE CONNECTION TO INTERMEDIATE HARNESS TO ICE MAKER ASSEMBLY (LOCATED LEFT SIDE OF UI CONTROL DRAWER)
IM2	2 PIN (1x2) INLINE CONNECTOR TO DC ICE MAKER FAN (LOCATED IN ICE MAKER ASSEMBLY)
IM3	6 PIN (2x3) INLINE CONNECTION TO ICE MAKER HARNESS: TWIST TRAY MOTOR, ICE TRAY TEMP SENSOR, BAIL ARM SWITCH (LOCATED IN ICE MAKER ASSEMBLY)
JP1	2 PIN (1x2) QUANTITY 2 CARD EDGE CONNECTORS (LOCATED INSIDE THE USER INTERFACE CONTROL DRAWER ASSEMBLY)
JP2	2 PIN (1x2) QUANTITY 2 CARD EDGE CONNECTORS (LOCATED INSIDE THE DOUBLE AND TRIPLE LED LIGHT LENS ASSEMBLIES)
LED1-LED13	2 PIN (1x2) CARD EDGE CONNECTORS LOCATED INSIDE LED LIGHT ASSEMBLY FOAMED IN HOUSINGS. THESE CONNECTORS PROVIDE +12VDC FROM THE MAIN CONTROL BOARD TO THE LED LIGHT PCBA LOCATED IN THE LENS ASSEMBLIES. THE +12VDC FROM THE MAIN CONTROL BOARD IS PROVIDED 1ST TO THE LOWER RIGHT SIDE SINGLE LIGHT PCBA, THEN TO THE UPPER RIGHT SIDE TRIPLE LIGHT PCBA, THEN TO THE UPPER LEFT SIDE TRIPLE LIGHT PCBA, THEN TO THE LOWER LEFT SIDE SINGLE LIGHT PCBA, THEN TO THE USER INTERFACE CONTROL DRAWER LEFT SIDE LIGHT PCBA THEN TO THE USER INTERFACE CONTROL DRAWER RIGHT SIDE LIGHT PCBA.

HARNESSES AND ELECTRONIC/ELECTRICAL COMPONENTS THAT CAN BE REPLACED FOR SERVICE
MAIN CONTROL PCBA (LOCATED ON BACK OF UNIT IN PLASTIC HOUSING)
AUXILIARY POWER SUPPLY PCBA (LOCATED IN PLASTIC HOUSING OVER COMPRESSOR)
INVERTER COMPRESSOR CONTROL ASSEMBLY (ATTACHED TO THE LEFT SIDE OF THE COMPRESSOR)
MAGNETIC REED SWITCH (LOCATED INSIDE THE UNIT IN THE TOP FRONT OF THE LINER BEHIND A PLASTIC COVER)
CABINET TEMPERATURE SENSOR (LOCATED ON THE RIGHT SIDE OF LINER BEHIND A PLASTIC COVER)
DEFROST TEMPERATURE SENSOR (LOCATED BEHIND EVAPORATOR COVER CLIPPED ONTO THE EVAPORATOR TUBE)
EVAPORATOR FAN (LOCATED IN AIR TOWER BEHIND EVAPORATOR COVER)
DEFROST HEATER (LOCATED BEHIND EVAPORATOR COVER) DEFROST HEATER HAS TWO THERMAL FUSES THAT PERMANENTLY OPEN CIRCUIT IF THEIR TEMPERATURE REACHES ABOVE 72°C (162°F), ONE ON THE LINE SIDE AND ONE ON THE NEUTRAL SIDE. IT ALSO HAS AN EARTH GROUND CLIP THAT MUST BE CONNECTED TO THE EVAPORATOR COVER IF THE DEFROST HEATER IS REPLACED.
USER INTERFACE CONTROL DRAWER (LOCATED INSIDE UNIT)
ICE MAKER ASSEMBLY (ATTACHED TO USER INTERFACE CONTROL DRAWER ASSEMBLY)
DC ICE MAKER FAN (LOCATED IN ICEMAKER ASSEMBLY)
LED LIGHT LENS ASSEMBLIES (LOCATED INSIDE THE UNIT)
LED LIGHT PCBA (LOCATED IN VARIOUS LOCATIONS)
INTERMEDIATE HARNESS TO ICE MAKER ASSEMBLY (LOCATED IN THE ICE MAKER ASSEMBLY)
USER INTERFACE CONTROL DRAWER INTERNAL HARNESS (LOCATED INSIDE THE USER INTERFACE CONTROL DRAWER ASSEMBLY)
JUMPER HARNESS JP1 BETWEEN LED LIGHT PCBA (LOCATED INSIDE THE USER INTERFACE CONTROL DRAWER ASSEMBLY)
JUMPER HARNESS JP2 BETWEEN LED LIGHT PCBA (LOCATED INSIDE THE DOUBLE AND TRIPLE LED LIGHT LENS ASSEMBLIES)
MACHINE COMPARTMENT HARNESS

