

# FRIGIDAIRE

GALLERY



## Slide-In Range

FGDS3065K F/W/B

30" Dual-Fuel



### Signature Features

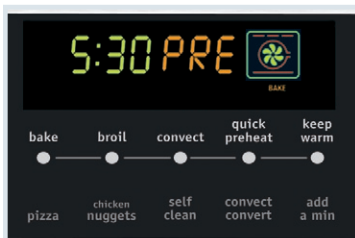

#### Quick Preheat

Preheat in less than six minutes.<sup>1</sup>



#### True Convection

Multi-rack baking is faster and more even with True Convection.



#### Quick Boil

Boil water faster with our 17,000-BTU burner.

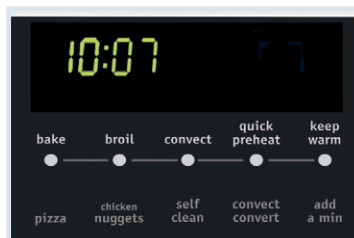

#### Express-Select™ Controls

Easily go from warm to boil.

### Effortless Performance

Effortless™ Convection Conversion  
Power and Quick Clean Options  
Broil (4,000W)

### Performance-Driven Style

Real Stainless Steel  
Effortless™ Oven Rack  
Even Baking Technology  
Continuous Cast Iron Grates  
with Black Matte Finish  
Low-Simmer Burner

### SpaceWise™ Design

SpaceWise™ Half Rack  
Keep Warm Drawer with  
SpaceWise™ Half Rack

### One-Touch Options

Keep Warm  
Chicken Nuggets  
Pizza  
Add-a-Minute

### More Easy-To-Use Features

Hidden Bake  
Extra-Large Window

A.D.A. Compliant\*

Sabbath Mode (Star-K® Certified)

### Capacities

4.2 Cu. Ft. Oven Capacity

1.6 Cu. Ft. Drawer Capacity

### Overall Exterior Dimensions

Height 36-5/8"

Width 30"

Depth 28-5/16"

### Available in:



\*When properly installed, meets the appliance standards in the American with Disabilities Act and the Architectural Barriers Act Accessibility Guidelines as published by the United States Access Board on June 23, 2004.

<sup>1</sup>Based on single rack cooking performance, not set temperature, using Quick Preheat.

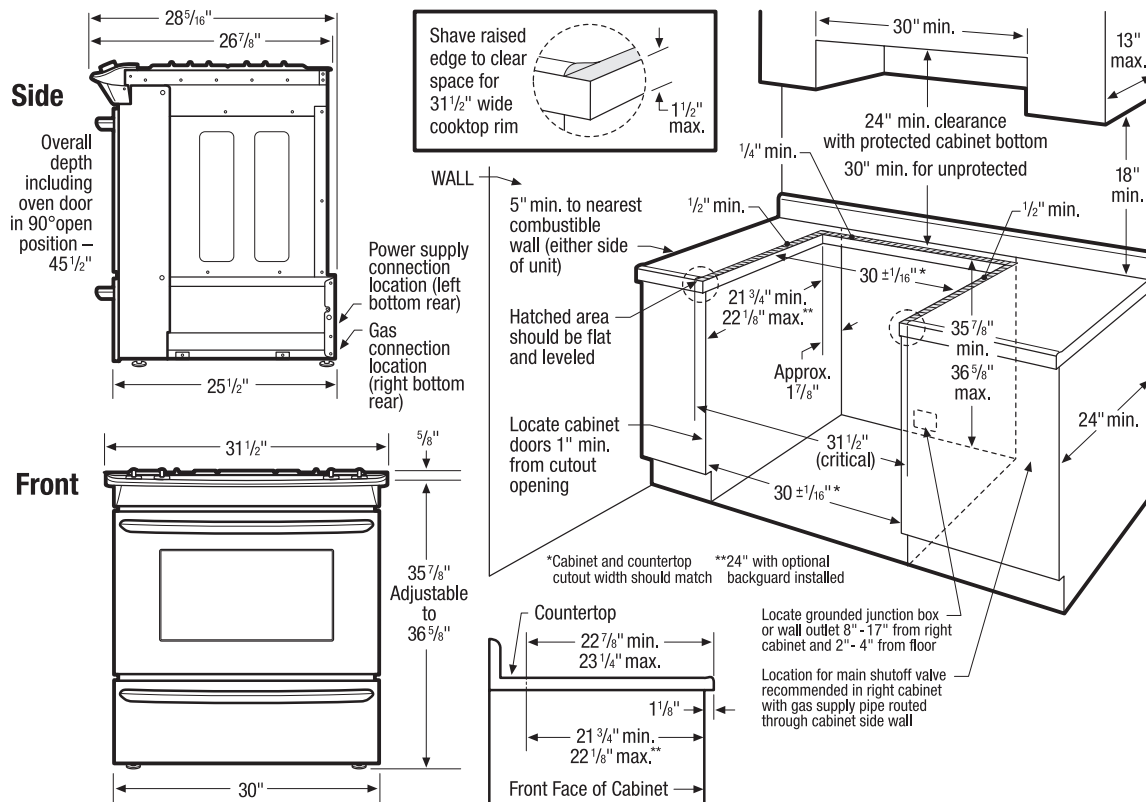

### Slide-In Range Specifications

- Product Shipping Weight (approx.) - 260 Lbs.
- Single phase 3- or 4-wire cable, 120/240 or 120/208 Volt, 60 Hertz, fused on both sides of line with ground. (If local code permits, range may be connected by hard-wiring or by means of power supply cord kit.)
- Connected Load (kW Rating) @ 240/208 Volts = 5.6/4.2kW
- Amps @ 240/208 Volts = 23/20 Amps
- Always consult local and national electric and gas codes.
- Range ships with 3/4" factory regulator.
- LP Gas conversion kit supplied.
- Gas supply piping can be routed through side wall of right cabinet. Right side cabinet is ideal location for main shutoff valve.
- Countertop MUST be level in all directions and adjustable range height at least 1/16" greater than tallest cabinet height, to ensure metal rangetop flange will fit properly on countertop edge.
- When installing optional Backguard Kit, cutout depth of 21-3/4" minimum/22-1/8" maximum needs increased to 24".
- Overhead cabinetry should not exceed a 13" maximum depth.
- Absolute minimum horizontal distance between overhead cabinets installed to either side of appliance must be no less than maximum width of appliance.
- Allow 24" minimum clearance between rangetop and bottom of cabinet when bottom of wood or metal cabinet is protected by not less than 1/4" flame-retardant millboard covered with not less than No. 28 MGS sheet steel, 0.015" stainless steel, 0.024" aluminum or 0.020" copper. Allow 30" minimum clearance when cabinet is unprotected.
- Allow 5" minimum clearance from edge of rangetop to nearest combustible wall on either side of unit.
- To reduce risk of fire when using overhead cabinetry, install range hood that projects horizontally a recommended minimum of 5" beyond bottom of cabinets.

### Countertop Preparation

For detailed preparation instructions, refer to installation guide on the web.

- Flat square-finish (flat) countertop requires no preparation since rangetop flange lays directly on countertop edge.
- Formed front-edged countertops require front molded edge to be shaved flat 3/4" from each front corner of opening.
- Tile countertops may need cut back 3/4" from each front corner of opening and/or rounded edge flattened.
- For existing cutout width greater than 30-1/16" reduce the 3/4" overlap dimension or for cutout width of 29", replace actual side trim panels with smaller side trim panels, available with optional Side Trim Kit (refer to detailed kit installation instructions).

**Note:** For planning purposes only. Refer to Product Installation Guide on the web at [frigidaire.com](http://frigidaire.com) for detailed instructions.

### Optional Accessories

- Rear Filler Kit: Stainless Steel - (PN# 901193-901S), White - (PN# 901193-9011), Black - (PN# 901193-9010).
- Side Panel Kit: Stainless Steel - (PN# 903074-901S), White - (PN# 903074-9011), Black - (PN# 903074-9010).
- Backguard Kit: Stainless Steel - (PN# 903046-901S), White - (PN# 903046-9011), Black - (PN# 903046-9010).
- Side Trim Kit: Stainless Steel - (PN# 903075-901S), White - (PN# 903075-9011), Black - (PN# 903075-9010).

