



# Freezer

FFCH13M2M W

Manual Defrost  
13 Cu. Ft. Chest



### Product Dimensions

Height (Including Lid)	35"
Width	42-3/4"
Depth	29-1/2"

### More Easy-To-Use Features

#### Defrost Water Drain

Use the drain to conveniently remove water during defrosting.

#### Adjustable Temperature Control

Select the correct temperature for your needs.

#### Lid Handle

ENERGY STAR®



Available in:

White  
(W)

## Signature Features

### Store-More™ Removable Baskets

Convenient lift-out storage for easy access to most small frozen items or items that are most frequently used.

### Lock with Pop-Out Key

The freezer key automatically ejects after locking the door so you won't leave it in the door.

### Power-On Indicator Light

Know at a glance that your freezer is working.

### Bright Lighting

Our bright lighting makes it easy to see what's inside.

Features	
Defrost	Manual
Adjustable Temperature Control	Yes
Interior Lighting	Bright
Store-More™ Removable Baskets	2
Food Organization System	
Defrost Water Drain	Yes
Lid Handle	Yes
Lock with Pop-Out Key	Yes
Power-On Light	Yes
Certifications	
ENERGY STAR®	Yes
CSA Rating	Household
Specifications	
Total Capacity (Cu. Ft.)	12.9
Annual Energy (kWH)	326
Annual Energy Cost (.1065/kWH)	\$35
Power Supply Connection Location	Left Bottom Rear
Voltage Rating	120V/60Hz/5A
Connected Load (kW rating) @ 120 Volts¹	.6
Amps @ 120 Volts	5
Minimum Circuit Required (Amps)	15
Shipping Weight (Approx.)	151 Lbs.

<sup>1</sup>An electrical supply with grounded three-prong receptacle is required. The power supply circuit must be installed in accordance with current edition of National Electrical Code (NFPA 70) and local codes & ordinances.

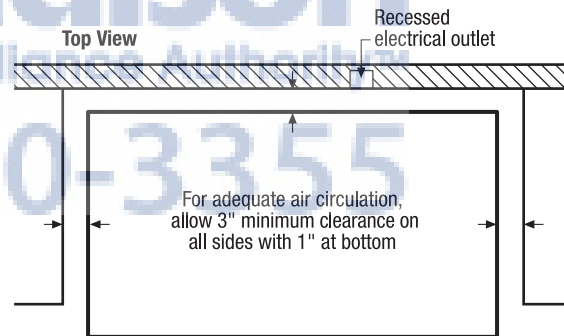
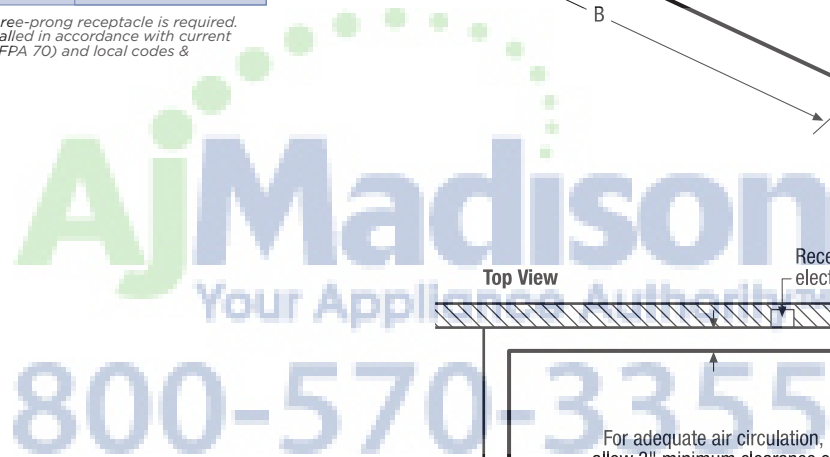
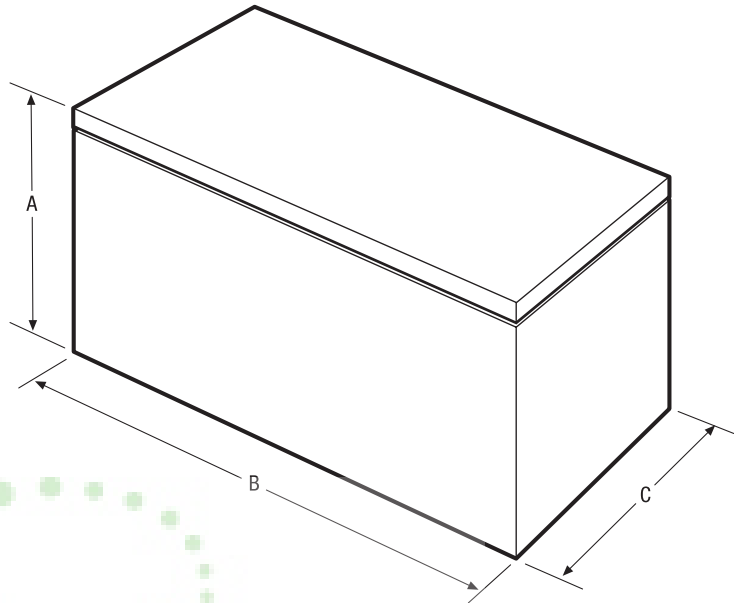

NOTE: For planning purposes only. Always consult local and national electric codes. Refer to Product Installation Guide for detailed installation instructions on the web at [frigidaire.com](http://frigidaire.com).



Product Dimensions	
A - Height (Including Lid)	35"
B - Width	42-3/4"
C - Depth	29-1/2"
Height with Lid Open 90°	60-13/16"

Accessories information available on the web at [frigidaire.com](http://frigidaire.com)

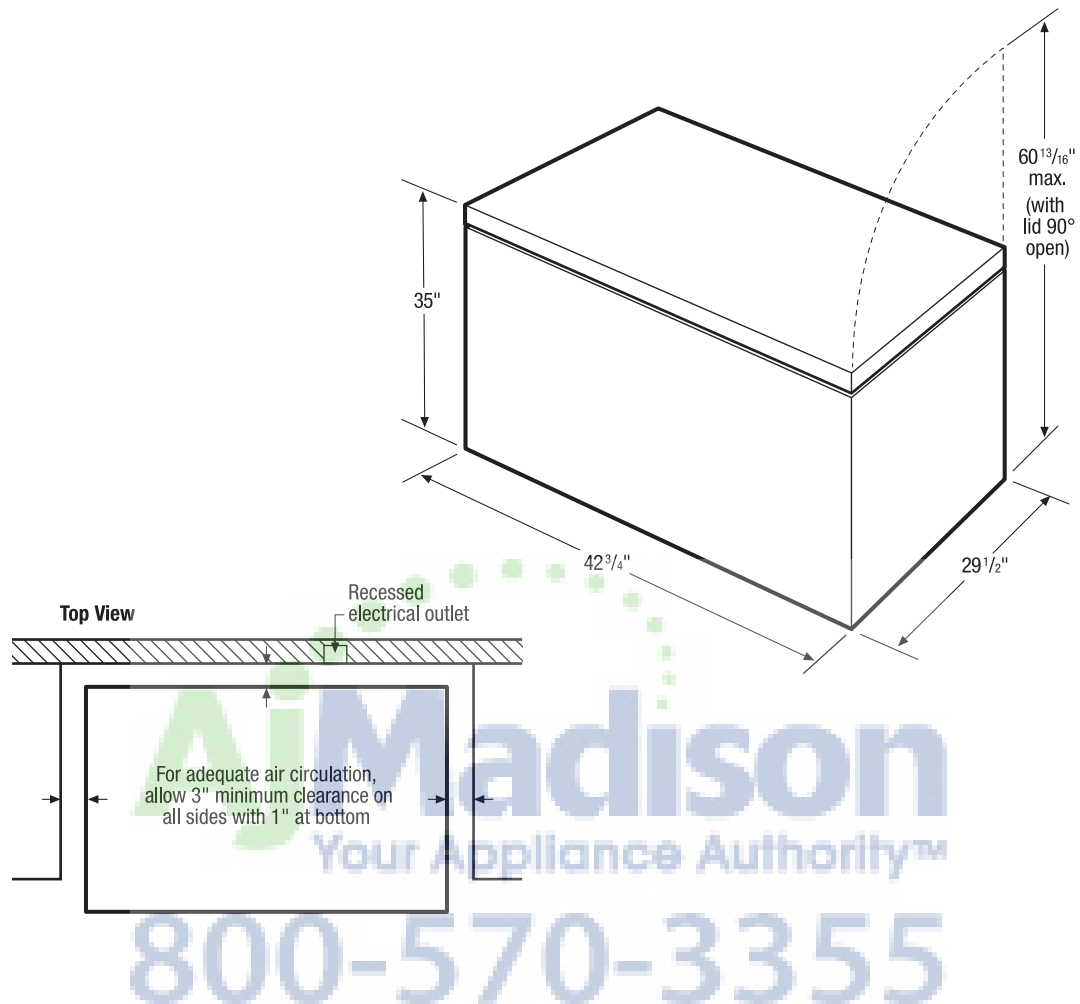

### Chest Freezer Specifications

- Product Shipping Weight (approx.) - 151 Lbs.
- An electrical supply with grounded three-prong receptacle is required. The power supply circuit must be installed in accordance with current edition of *National Electrical Code (NFPA 70)* and local codes & ordinances.
- Voltage Rating - 120V / 60 Hz / 5 Amps
- Connected Load (kW Rating) @ 120 Volts = 0.6 kW
- Amps @ 120 Volts = 5 Amps
- Always consult local and national electric codes.
- For adequate air circulation, allow 3" minimum clearance on all sides with 1" at bottom.
- Locate where surrounding air temperature will not exceed 110° F, to ensure optimum performance. (Temperatures 32° F and below will NOT affect operation.)
- All bottom corners of unit MUST rest firmly on solid level surface of hard material, same height as flooring. Surface must be strong and stable enough to support unit when fully loaded.
- Equipped with adjustable leveling legs to ensure unit is level, which is required in order to function properly.

**Note:** For planning purposes only. Refer to Product Installation Guide on the web at [frigidaire.com](http://frigidaire.com) for detailed instructions.