

FFAR22LW

20.18" x 17.38" x 19.0" (H x W x D)

Compact all-refrigerator with automatic defrost and front lock

Highlights:

- Perfectly sized compact to fit tight spaces
- Automatic defrost saves you time and maintenance
- Factory-installed lock provides security you can depend on





Aj Madison
 Your Appliance Authority™
800-570-3355

Front-mounted lock	Keyed lock for a secure interior
Automatic defrost	Reduced maintenance with auto defrost system
Reversible door	User reversible door swing
Adjustable thermostat	Rear mounted to prevent accidental adjustments
Matching freezer available	Matches SUMMIT FS22L all-freezer
Flat door liner	Interior design is ideal for storing sensitive materials
100% CFC	Environmentally friendly design without ozone-damaging chemicals

Specifications:

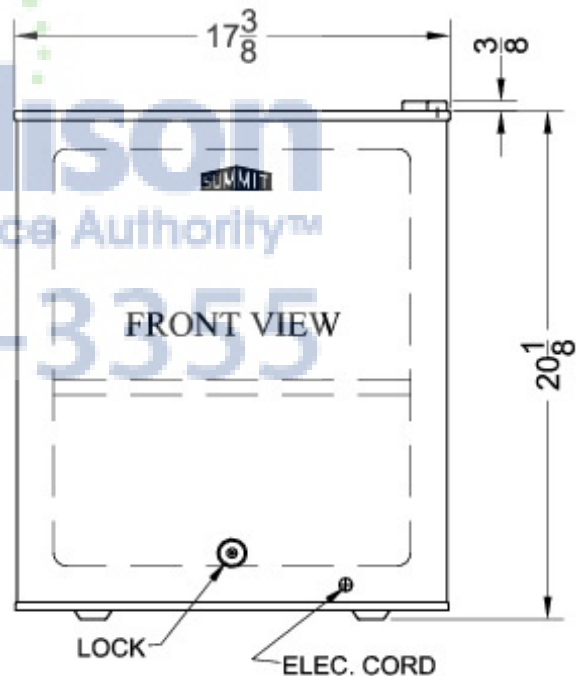
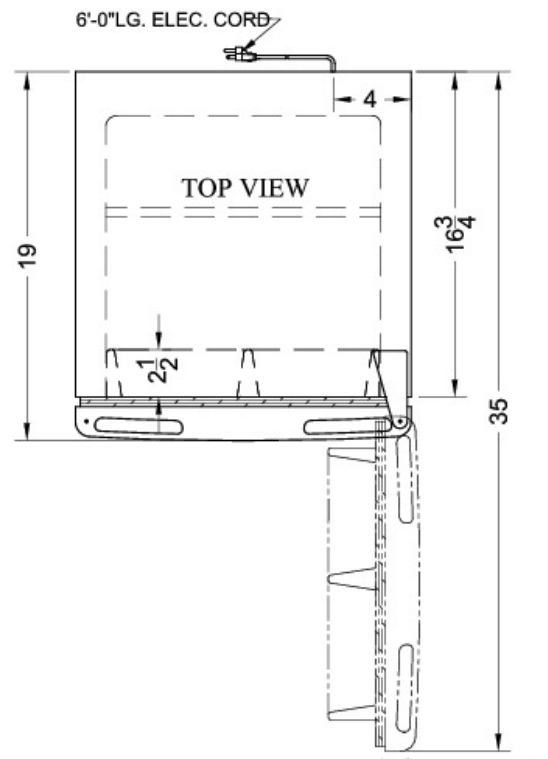
Height	20.18"
Width	17.38"
Depth	19.0"
Capacity	1.6 cu.ft.
Interior Height 1	16.5"
Interior Width 1	14.18"
Interior Depth 1	14.5"
Comp Step Height	6.75"
Comp Step Width	14.18"
Comp Step Depth	5.25"
Shipping Weight	55.0 lbs.
Weight	35.3 lbs.
Energy Usage/Year	316.0 kWh/year
Amps	1.2
Canadian Electrical Safety	CSA
Voltage/Frequency	115 V AC/60 Hz
US Electrical Safety	CSA
Reversible	Yes
Door Swing	RHD
Shelf Quantity	1
Shelf Type	Wire
Defrost Type	Automatic
Height to Hinge Cap	20.5"
Thermostat Type	Dial
Freon Type	R134a
Freon Oz	1.67
High Side PSI	270.0
Level Legs Quantity	2
Low Side PSI	103.0
Compressor Warranty	5 Years
Parts/Labor Warranty	1 Year



AjMadison
Your Appliance Authority™
800-570-3355

Summit Appliance Division, Felix Storch, Inc.
770 Garrison Ave • Bronx, NY 10474
Phone: 718-893-3900 • Fax: 718-842-3093
Email: info@summitappliance.com