

FF944W

64.75" x 22.0" x 26.0" (H x W x D)

8.9 cu.ft. frost-free refrigerator-freezer in white

Highlights:

Unique 22" width is ideal for apartment and space-challenged kitchens while still offering nearly 9 cu.ft. of storage

True frost-free operation saves you maintenance by preventing icy buildup

Fully featured for convenient storage with a crisper, adjustable shelves, and more

Door shelves offer convenient storage solutions



AjMadison
Your Appliance Authority™
800-570-3355

Thin-line design	Limited space is no problem for our thin-line models, designed specifically for those hard-to-fit spots
Frost-free operation	No-frost convenience for reduced user maintenance
Adjustable glass shelves	Spill-proof shelves made from solid safety glass offer convenient and flexible storage in the refrigerator section
Full freezer shelf	Wire shelf included for storage convenience
Door storage	Refrigerator door includes four racks ideal for storing condiments and tall bottles. Freezer door includes one full and one half shelf
Clear crisper	Get the longest life and best taste out of produce by storing greens in a convenient slide drawer that tilts out for easy loading and unloading
Reversible doors	Keep your options flexible with reversible doors that are easy to switch when your arrangement changes
Interior light	Automatically illuminates when you open the refrigerator door
100% CFC free	Environmentally friendly design without ozone-damaging chemicals

FF944W Specifications:

Height	64.75"
Width	22.0"
Depth	26.0"
Capacity	8.9 cu.ft.
Interior Height 1	40.5"
Interior Width 1	17.0"
Interior Depth 1	17.0"
Interior Height 2	16.0"
Interior Width 2	16.25"
Interior Depth 2	13.25"
Comp Step Height	9.75"
Comp Step Width	17.0"
Comp Step Depth	4.0"
Shipping Weight	158.0 lbs.
Voltage/Frequency	115 V AC/60 Hz
Canadian Electrical Safety	ULC
US Electrical Safety	UL
Amps	1.1
Energy Usage/Year	375.0 kWh/year
Reversible	Yes
Door Swing	RHD
Crisper Quantity	1
Shelf Quantity	3
Adjustable Shelf	true
Shelf Type	Glass and Wire
Crisper Cover Type	Glass
Crisper Finish	Transparent
Full Door Shelf Quantity	5
Half Door Shelf Quantity	1
Defrost Type	Frost-Free
Height to Hinge Cap	65.75"
Depth with door at 90°	44.25"
Light	true
Thermostat Type	Dial
Fan Type	Interior
Level Legs Quantity	2
Freon Oz	3.84
Refrigerant Type	R134a
Compressor Warranty	5 Years
Parts/Labor Warranty	1 Year

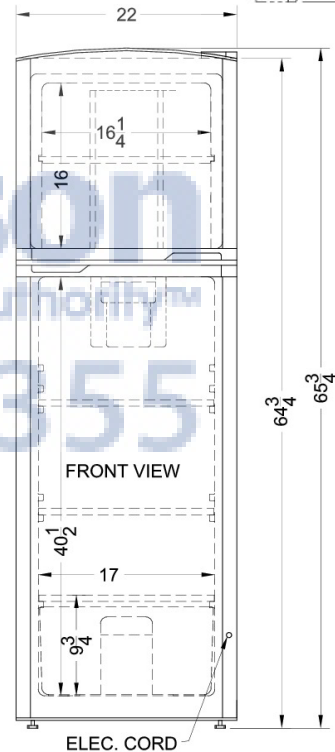
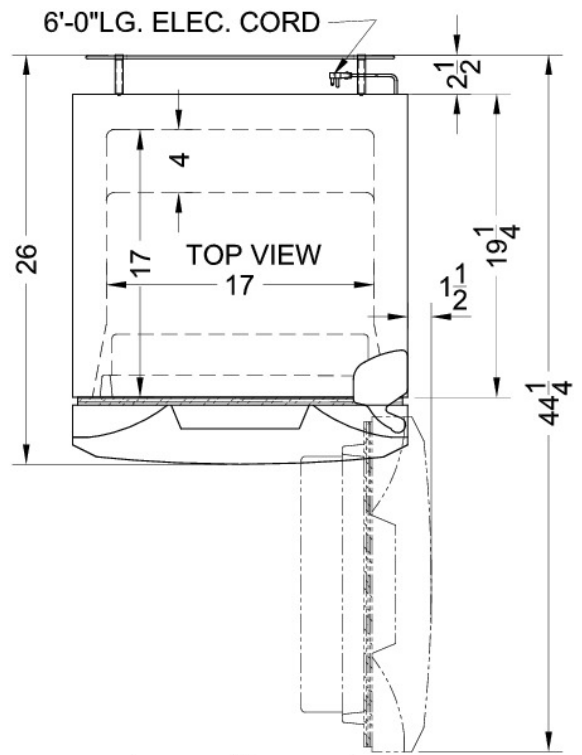



 Your Appliance Authority™

 800-570-3355

Summit Appliance Division, Felix Storch, Inc.
 770 Garrison Ave • Bronx, NY 10474
 Phone: 718-893-3900 • Fax: 718-842-3093
 Email: info@summitappliance.com