

FF1620W

69.13" x 29.13" x 26.5" (H x W x D)

Frost-free refrigerator-freezer with 15.8 cu.ft. capacity

Highlights:

Just 26 ½" deep with a full 15.8 cu.ft. capacity

True frost-free operation saves you maintenance by preventing icy buildup

Deluxe interior with glass shelves, two crispers with humidity control, and door storage

Unique suspended ice trays and mini-crisper let you maximize shelf space



AjMadison
Your Appliance Authority™
800-570-3355

Frost-free operation	No-frost convenience for reduced user maintenance
Adjustable glass shelves	Rearrange refrigerator space to accommodate all sizes or remove shelves for simple cleanup
Two clear crispers with humidity control	Get the longest life and best taste out of produce by storing greens in convenient slide drawers
Door storage	Store items right on the door for easy access
Hanging ice cube trays	Unique design lets you suspend the trays from shelves and adjust from side to side
Hanging deli crisper	Mini-drawer suspends from a refrigerator shelf and can be adjusted from side to side
Reversible doors	Keep your options flexible with reversible doors that are easy to switch when your arrangement changes
Full freezer shelf	Removable shelf for added convenience
Interior light	Automatically illuminates when you open the door
Adjustable thermostat	Manage the temperature with ease and accuracy

Specifications:

Height	69.13"
Width	29.13"
Depth	26.5"
Capacity	15.8 cu.ft.
Interior Height 1	38.75"
Interior Width 1	25.0"
Interior Depth 1	22.25"
Interior Height 2	19.63"
Interior Width 2	24.5"
Interior Depth 2	17.0"
Voltage/Frequency	115 V AC/60 Hz
Amps	3.0
Canadian Electrical Safety	ULC
Energy Usage/Year	457.0 kWh/year
US Electrical Safety	UL
Reversible	Yes
Door Swing	RHD
Crisper Quantity	2
Shelf Quantity	2
Adjustable Shelf	true
Shelf Type	Glass
Crisper Cover Type	Glass
Crisper Finish	Transparent
Full Door Shelf Quantity	7
Gallon Storage	true
Wheel Quantity	4
Defrost Type	Frost-Free
Depth with door at 90°	54.63"
Thermostat Type	Dial
Fan Type	Interior
Light	true
Freon Type	R134a
Freon Oz	3.5
Low Side PSI	140.0
High Side PSI	335.0
Level Legs Quantity	2
Parts/Labor Warranty	1 Year
Compressor Warranty	5 Years

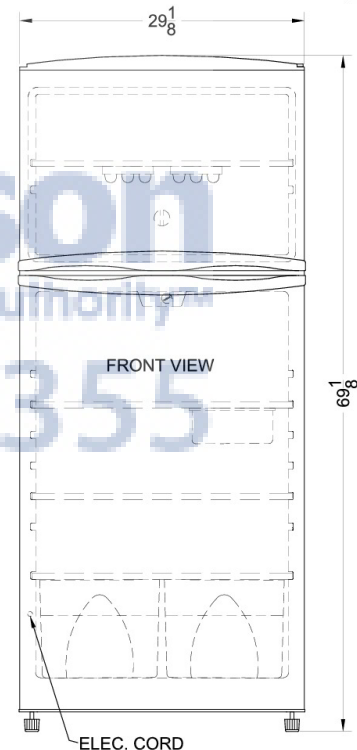
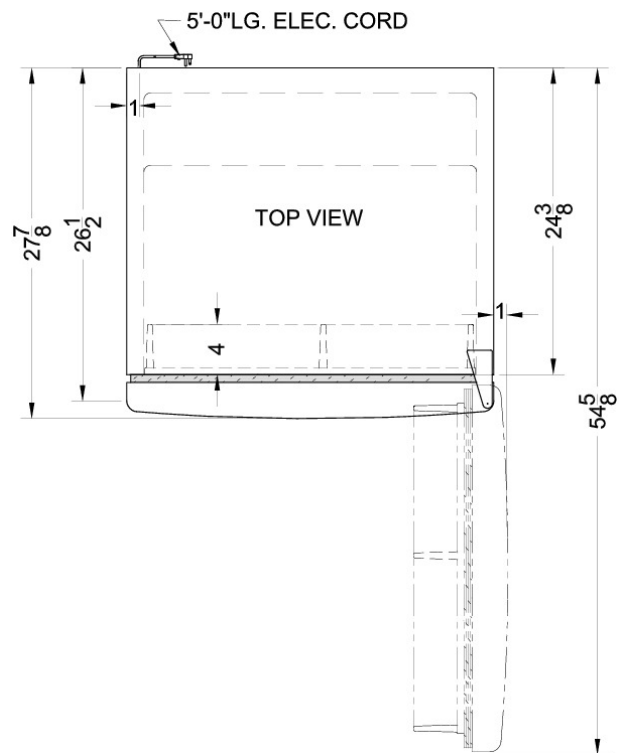

AjMadison
Your Appliance Authority™
800-570-3355

Summit Appliance Division, Felix Storch, Inc.
770 Garrison Ave • Bronx, NY 10474
Phone: 718-893-3900 • Fax: 718-842-3093
Email: info@summitappliance.com