

FF1525PL

73.0" x 26.0" x 26.25" (H x W x D)

Counter depth 14 cu.ft. frost-free refrigerator-freezer in platinum finish, part of the Ingenious Series designed for true user convenience in the kitchen

Highlights:

Part of the Ingenious Series of refrigerator-freezers, designed with extra care for modern user convenience

Over 14 cu.ft. of storage in a unique counter depth fit

Modern platinum finish offers an attractive look for any kitchen

Deluxe interior includes spillproof glass shelves and multiple crispers



AjMadison
Your Appliance Authority™
800-570-3355

Frost-free operation	Ensures low maintenance operation by eliminating the manual defrosting process
Platinum finish	Stylish look suits many kitchen styles
Adjustable safety glass shelves	Rearrange refrigerator and freezer space to accommodate all sizes or remove shelves for simple cleanup
Door storage	Full and half shelves in both compartments, with a large refrigerator door shelf that can accommodate gallon-sized containers
Express Chill Zone	Special freezer feature lets you cool down items quickly in 60, 45, 30, 20, 15, or 10 minute increments, with an audible alarm to tell you when your item is ready
Smart Station	Unique door compartment lets you store selected items in a way that's easily accessible without opening the door
Humidity controlled crisper	Large crisper drawer offers the ideal conditions for storing produce
Deli crisper	Clear drawer compartment is ideally designed for deli storage
Sliding mini-crisper	Great for smaller items, the compact crisper can be moved from side to side for added flexibility
Smart Fill Ice Station	No-spill ice cube system includes a removable cylinder that when filled, will automatically fill a small ice tray that can then be easily emptied into a storage box with a simple lever

FF1525PL Specifications:

Height	73.0"
Width	26.0"
Depth	26.25"
Capacity	14.12 cu.ft.
Shipping Weight	215.0 lbs.
Weight	200.0 lbs.
Amps	1.2
Voltage/Frequency	115 V AC/60 Hz
Energy Usage/Year	427.0 kWh/year
US Electrical Safety	UL
Canadian Electrical Safety	ULC
Reversible	No
Door Swing	RHD
Crisper Quantity	2
Shelf Quantity	4
Adjustable Shelf	true
Shelf Type	Glass
Crisper Cover Type	Glass
Crisper Finish	Transparent
Full Door Shelf Quantity	3
Half Door Shelf Quantity	3
Gallon Storage	true
Wheel Quantity	2
Defrost Type	Frost-Free
Depth with door at 90°	50.63"
Thermostat Type	Digital
Fan Type	Interior
Light	true
High Side PSI	335.0
Freon Oz	3.88
Refrigerant Type	R134a
Low Side PSI	140.0
Level Legs Quantity	2
Compressor Warranty	5 Years
Parts/Labor Warranty	1 Year

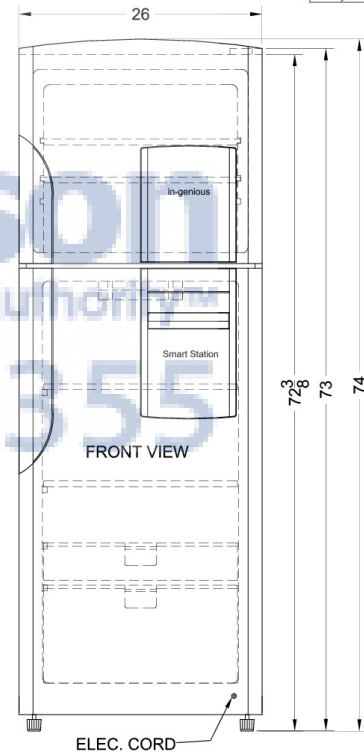
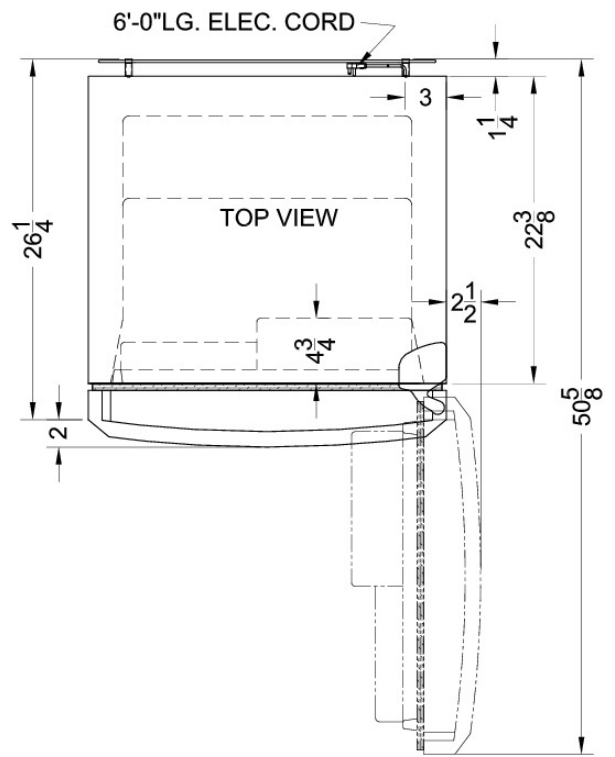

AjMadison
 Your Appliance Authority™
 800-570-3355

Summit Appliance Division, Felix Storch, Inc.
 770 Garrison Ave • Bronx, NY 10474
 Phone: 718-893-3900 • Fax: 718-842-3093
 Email: info@summitappliance.com