

50's Retro Style Mini Refrigerator,
Black, Left hand hinge
EAN13: 8017709182267

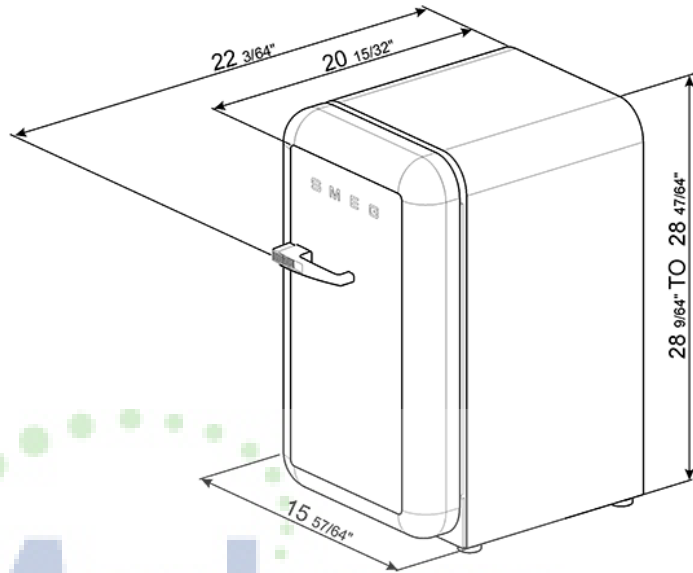

• Capacity 1.5 Cu. Ft. • Absorption cooling = ultra low noise level • Automatic defrost • LED Internal light • 2 adjustable shelves • Door storage: 1 balcony shelf, 1 bottle shelf • Ice cube tray • Voltage: 115 V • Current: 10Amps • Frequency: 60Hz • Dimensions: (H x W x D) 28 9/64" x 15 57/64" x 22 3/64" • Gross Weight: 65lbs. • Net Weight: 51.2 lbs.

Versions

• FAB5URNE - Black, hinges on the right • FAB5URO - Orange, hinges on the right • FAB5ULO - Orange, hinges on the left • FAB5URP - Cream, hinges on the right • FAB5ULP - Cream, hinges on the left • FAB5URR - Red, hinges on the right • FAB5ULR - Red, hinges on the left