

FAB28ULCR3 New product

50's Retro style

'50s Style fridge with ice compartment, Cream, Left-hand hinge, 24" in-width

EAN13: 8017709271749

REFRIGERATOR

Multiflow Cooling System

Fresh food capacity: 9 cu ft

Life plus zone 28 - 37°F

LED internal light

Automatic defrost

3 adjustable glass shelves

Glass crisper cover

Fruit and vegetable drawer on telescopic guides

Inner door with 1 adjustable shelf and 1 bottle shelf with wire support

FREEZER

Frozen food capacity: 0.92 cu ft

Ice cube tray

DOOR

1 bin with transparent cover

1 bottle storage bin

2 adjustable storage bins

TECHNICAL FEATURES

Energy consumption: 230 kWh/year

Voltage: 120 V

Frequency: 60 Hz

Noise level: 38 dB(A)

Dimensions (HxWxD): 60 1/4" x 23 2/3" x 30 1/4" (handle included)

Dimensions (with door opened to 90°) (HxWxD): 60 1/4" x 30 1/16" x 47 1/8"

Net weight: 156 lbs



Functions



Versions

- **FAB28URCR3** - Cream, right hand hinge



FAB28ULCR3

50's Retro style

fridge
free standing
cream
24"



Energy Star and ISO14001 Certified:

The SMEG production process is carefully-managed in order to limit the environmental impact as much as possible. The ISO process is checked and certified by Independent International bodies IQNET and CISQ (SMEG complies with the standard ISO14001). All SMEG dishwashers and every new refrigerator model are ENERGY STAR-qualified through the US Department of Energy and US Environmental Protection Agency. Energy efficiency is important to SMEG, and our engineers are constantly working to keep the energy and water consumption of each dishwasher and refrigerator as low as-possible. ENERGY STAR-certified products use approximately 40% less energy than the federal minimum standard for energy consumption. By choosing an ENERGY STAR-certified product, you are helping to preserve the environment without compromising on product quality or performance.



SMEG U.S.A. INC.
A&D BUILDING
150 EAST 58th STREET, 7th FLOOR
NEW YORK, NY, 10155
Tel. +1 212 265 5378
Fax +1 212 265 5945



FAB28ULCR3

50's Retro style

fridge
free standing
cream
24"

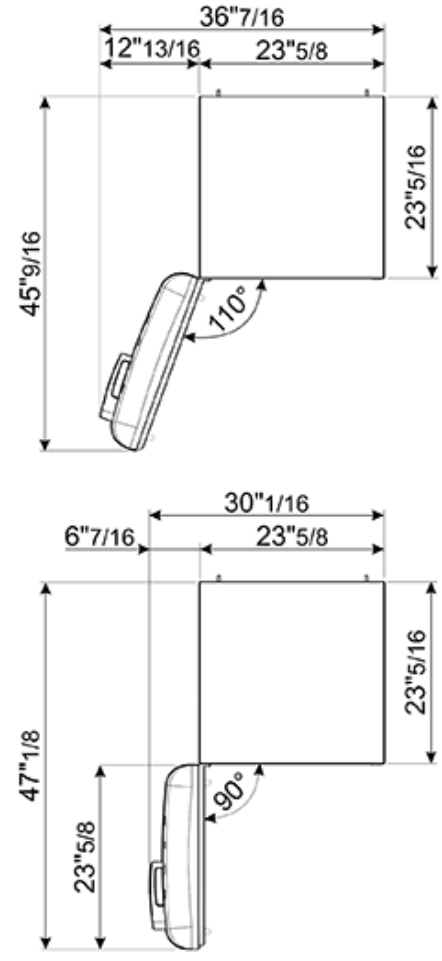
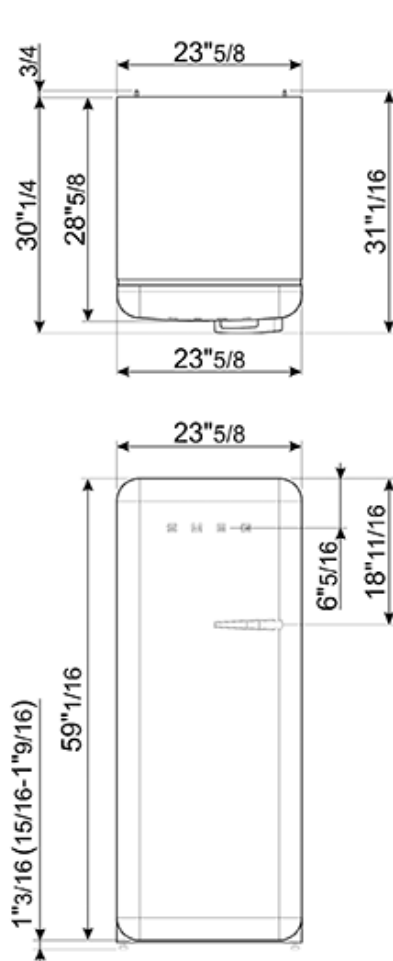

SMEG U.S.A. INC.
A&D BUILDING
150 EAST 58th STREET, 7th FLOOR
NEW YORK, NY, 10155
Tel. +1 212 265 5378
Fax +1 212 265 5945