

# FULGOR

## MILANO

### 36" Electric cooktop with frontal control 600 SERIES

### Weight & Dimensions

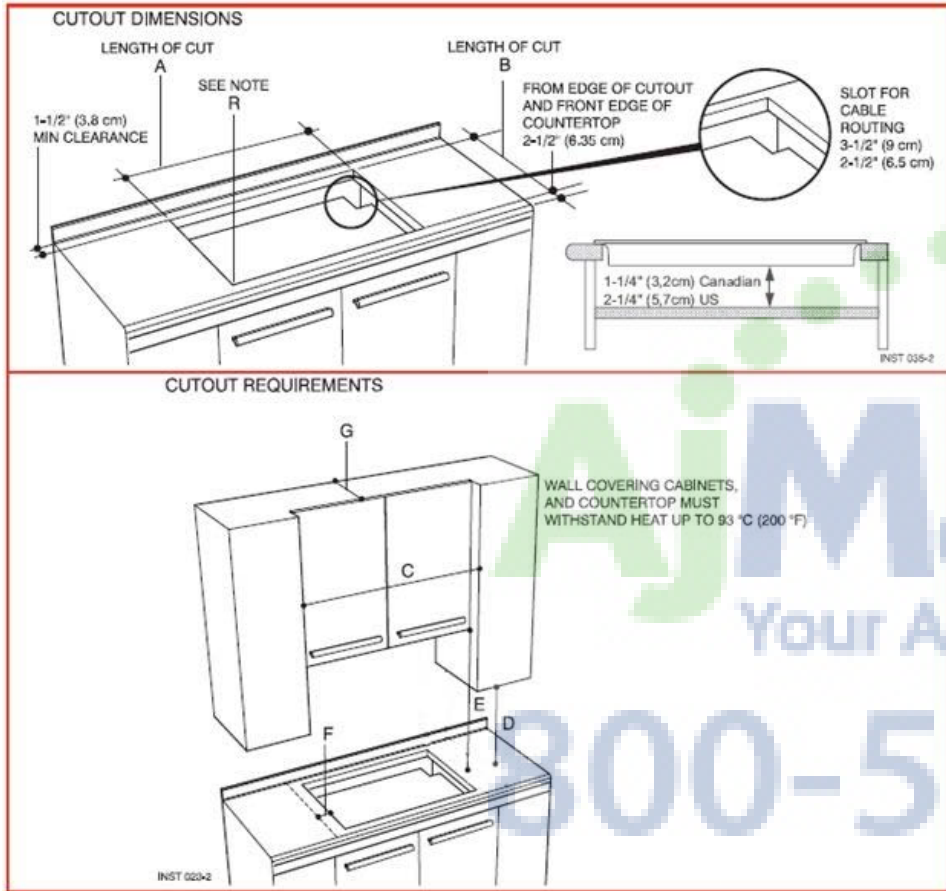

Ltr.	CUTOUT DIMENSION	inch	cm
A	Cutout Width	Min 34-1/16" Max 34-5/16"	Min 86,5 Max 87,2
B	Cutout Depth	Min 19-1/4" Max 19-5/8"	Min 49,0 Max 49,8
C	Opening between cabinets	Min 36" min	Min 91,4
D	Height from countertop to nearest cabinet on either side of unit	Min 18"	Min 45,7
E	Clearance from countertop to unprotected overhead surface	Min 30"	Min 76,2
F	Clearance from cutout to side wall on the left and right of the unit	Min 2"	Min 5
G	Depth of unprotected overhead cabinets	Min 13"	Min 33

PACKAGING		lb / inch	Kg / mm
GROSS WEIGHT		43 lb	19.4 Kg
DIMENSION	W	40"1/2	1030
	D	23"1/2	598
	H	7"1/4	185

#### IMPORTANT

Under the cooktop it is necessary to install a partition, spaced from the bottom of the appliance as shown in figure above.

#### \* NOTE

24" (61 cm) min. clearance if bottom of wood or metal cabinets is protected by not less than 1/4" (0.6 cm) flame retardant millboard covered with no less than No. 28 MSG sheet steel 0.015" (0.04 cm) stainless steel, or 0.024" (0.06 cm) aluminum or 0.020" (0.05cm) copper. 30"(76.2 cm) min. clearance between top of cooking platform and bottom of unprotected wood or metal cabinet

#### NOTE

R  
Radius corners of cutout and file to insure smooth edges and prevent corner cracking. Recommend 1/4" or 3/8" diameter drill in each

