

ACCENTO PROFESSIONAL 36"

36" DUAL FUEL PROFESSIONAL RANGE



CODE ID



F4PDF366S1



Heavy Duty Grates



Continuous Grate Surface



Dual Crescendo Burner



Dual Convection



Self Clean Oven



Multi-level cooking



Cool Touch Door



Digital Controls



Fast Pre-Heat

COLOR KIT

	STAINLESS STEEL
	MATTE BLACK RAL 9004
	MATTE WHITE RAL 9016
	GLOSSY RED RAL 3003

OPTIONAL ACCESSORIES

ACDKIT36 ...	Colour kit
FMWOK	Wok ring
FMSIM	Simmer plate
F6BG30BCI	Island trim
F6BG30STD	Standard trim
F6BG30HBT	High back trim
FMGRID30	Griddle
FMTRP30	Telescopic rack

COOKING SURFACE

3 Heavy Duty, continuous cast iron grates
One piece, matte finish porcelain burner bowl
3 Dual-Flame Crescendo Burners
3 X 18,000 BTU max (NG)
3 Rapid Burners
3 X 15,000 BTU max(NG)
Natural Gas (LP convertible)

OVEN

Dual True Convection
Self-cleaning oven with Multifunction baking
Black Porcelain enamel interior
Cool to the touch door
Extra-large baking cavity and viewing area
3 Halogen lights for flawless visibility
Gross capacity 5.7 cu. ft.
2 chromed racks
Enameled Broiler Pan

OVEN FUNCTIONS

Bake
Broil
Roast
Convection
True Convection
Warm / Proof / Dehydrate
Electronic cooking programmer
Fast Pre-Heat
Self-Clean
Sabbath Mode

ACCENTO

36" DUAL FUEL PROFESSIONAL RANGE

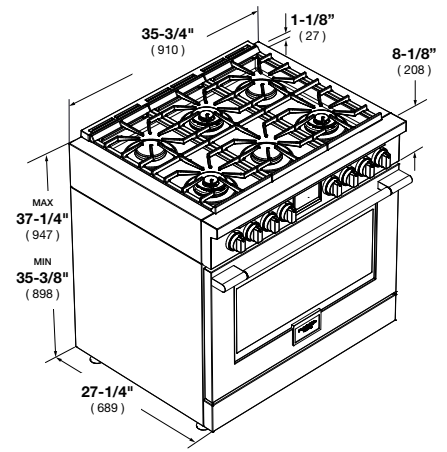

CODE ID		F4PDF366S1 - 36" DUAL FUEL PROFESSIONAL RANGE			
Series and Finish		400 Series - Professional Design - Stainless Steel			
CONTROL PANEL					
Control Type		Electronic			
Display: Clock - Temperature - Function		White LED			
COOKTOP					
Cooking Surface		Black Enameled			
Type		GAS (NG or LP)			
GAS COOKTOP FEATURES					
		Electric Flame Ignition and Re-ignition	L.P. Conversion Kit	Top Mount Injectors	
		Flame-out sensing	Dual Crown Brass Burner	Pressure Regulator	
Cooking Zones		6			
Burners types		Dual Flame/Rapid Burners			
Power Front L+R	(Max/Min) G20-5" (NG)	18000 (BTU/h) - 5300W / 950 (BTU/h) - 275W			
Power Rear L+R	(Max/Min) G20-5" (NG)	15000 (BTU/h) - 4400W / 2200 (BTU/h) - 645W			
Power Front Middle	(Max/Min) G20-5" (NG)	15000 (BTU/h) - 4400W / 2200 (BTU/h) - 645W			
Power Rear Middle	(Max/Min) G20-5" (NG)	18000 (BTU/h) - 5300W / 950(BTU/h) - 275W			
Power Front L+R	(Max/Min) G31-10" (LP)	15000 (BTU/h) - 4400W / 950 (BTU/h) - 275W			
Power Rear L+R	(Max/Min) G31-10" (LP)	12000 (BTU/h) - 3500W / 2200 (BTU/h) - 645W			
Power Front Middle	(Max/Min) G31-10" (LP)	12000 (BTU/h) - 3800W / 2200(BTU/h) - 645W			
Power Rear Middle	(Max/Min) G31-10" (LP)	15000 (BTU/h) - 4400W / 950(BTU/h) - 275W			
OVEN		Electric Pyro			
Oven Type		Multifunction 2 Fans (True Euro Conv.)			
Temperature Regulation		Electronic			
OVEN FUNCTIONS					
		Pyrolytic Self-Clean with automatic door latch	Pizza (Lower Convection)	Proof (Warm)	
		True European Convection Bake (Multi level)	Bake	Broil	
		Dehydrate	Thaw (Defrost)	Convection Broil	
		Convection Roast	Oven Lights	Keep warm (Warm Plus)	
		Fast Preheat			
ELECTRIC OVEN FEATURES					
		Preset/Last Used Temperature Memory	Preheat bar (25%, 50%, 75%, 100%)	Automatic Fast Preheat	
		Child Door Lock	Sabbath Mode	Hour Clock Formats AM/PM	
		°F Degree unit			
OVEN DOOR(S)					
Oven Glass Window		Deep Embossed Window			
Door Cooling System		4 Pane Heat Resistant Glasses			
Door Hinges		Heavy Duty Steady Tilt			
Handle Style		Stainless Steel Tube d30mm with Metal terminals			
OVEN CAVITY					
Net Capacity (cbft)		5.7			
Cavity Enamel Colour		Black			
Rack Positions		6			
Oven Lights		3x20W Halogen			
HEATING ELEMENTS (@240V)					
Broil Upper Heating Element		3500 W			
Upper Auxiliary Element Wattage		1032 W			
Concealed Bake Lower Heating Element		3000 W			
Convection Element		2 x 1300 W			
OVEN ACCESSORIES					
Chromed Racks		2			
Enameled Grill set (basin + anti splash)		1			
Telescopic Chromed Rack		Only as optional ACCESSORY			
Meat Probe		Only as optional ACCESSORY			
DIMENSIONS/WEIGHT					
Overall dim - Width		35 - 3/4"	(910 mm)		
Overall dim - Height (min - max)		39"	(993 mm)		
Overall dim - Depth		29 - 3/4"	(756 mm)		
POWER / RATINGS (208/240 V, 60 HZ)					
kW / Amps rating at 120-240V, 60Hz		3.84 kW - 16.9 A			
kW / Amps rating at 120-208V, 60Hz		3.54 kW - 17.5 A			
Power Cable		Nema 14-50P			
INSTRUCTIONS FOR USE					
Use & Care Manual / Installation Manual		English / French / Spanish			