



800-570-3355



Index

Ovens



Single & Double Ovens **600 SERIES**
6 - 17

Single Ovens **400 SERIES**
18 - 25

Single Ovens **100 SERIES**
26 - 35

Accessories & Technical Data
36 - 41

Induction Cooktops **600 SERIES**
44 - 51

Radiant Cooktops **600 SERIES**
52 - 59

Radiant Cooktops **300 SERIES**
60 - 69

Gas Cooktops **400 SERIES**
70 - 79

Gas Cooktops **300 SERIES**
80 - 87

Accessories & Technical Data
88 - 94



Cooktops

FULGOR
MILANO



FULGOR
MILANO

iMadison
Your Appliance Authority
800-570-3355



Brand

1949 Fulgor is founded as a coal-stove factory

1955 Fulgor first produces freestanding gas kitchens

1960 Meneghetti is founded as a tool -and metal-pressing factory

1974 Fulgor's built-in cooktops are created

1976 Fulgor's electric cooktops first produced

1987 First production of Meneghetti's cooktops

1990 Creation of Fulgor's first glass cooktop

1991 First European production of Fulgor's pyrolytic ovens

1994 First European production of Fulgor's pyrolytic ovens for the North American market

2000 First production of Meneghetti's ovens

2006 Fulgor invents world's first dual-flame burner

2007 Meneghetti becomes first European cooktop manufacturer

2009 First production of Meneghetti's cooker hoods

Acquisition of Fulgor by Meneghetti S.p.A.

Fulgor celebrates 60 years; Fulgor-Milano is born

2010 Meneghetti and Fulgor move forward, bringing time-honored tradition together with the latest technologies





AjMadison
Your Appliance Authority™
800-570-3355

Ovens



True **Italian design** must be as exquisite in appearance as it is in performance.

Beauty infused with intelligence; art informed by craftsmanship; form integrated with function. At Fulgor Milano, we design extraordinary appliances

for everyday living – enriching **how** people live in the spaces **where** they live. Our award-winning designs are inspired by our strong passion for food, family, friends and fine living. Our innovative line of appliances and kitchen products combine the quality, reliability and affordability that families demand with a refined elegance and understated sophistication that's unmatched at any price. Sleek surfaces, clean lines and intuitive controls transform kitchens and dining areas into open, stylish spaces that draw crowds but never feel crowded.



AjMadison
Your Appliance Authority™
800-570-3355



600 Series

Single & Double Ovens



A modern workhorse that marries style and innovation. With many preset cooking functions, the 600 series ovens help you prepare your meals with efficiency and ease. Child safety locks and cool touch doors ensure you and your family will be protected from high temperatures while cooking and during the self clean cycle. This series offers the fastest and most versatile self clean mode available, a dual convection system for high quality performance and an oversized oven space for big results. With 5 broil levels and a selection of accessories available to you, the 600 series ovens deliver both luxury and convenience.

SAFETY FEATURE: COOL DOOR

Rest assured, your hands are safe with us.
Our cool-door technology has a proven guarantee



EXTRA LARGE CAVITY

Imagine the efficiency of being able to use multiple levels of a huge oven at once. We consider it an advantage, don't you?



TELESCOPIC RACK

Our fully retractable telescopic rack makes accessibility to your cooking more convenient



MEAT PROBE

Precise cooking performance with our meat probe, available in our single ovens and upper cavity of the double ovens



DIMENSIONS

single ovens 30"x 30"

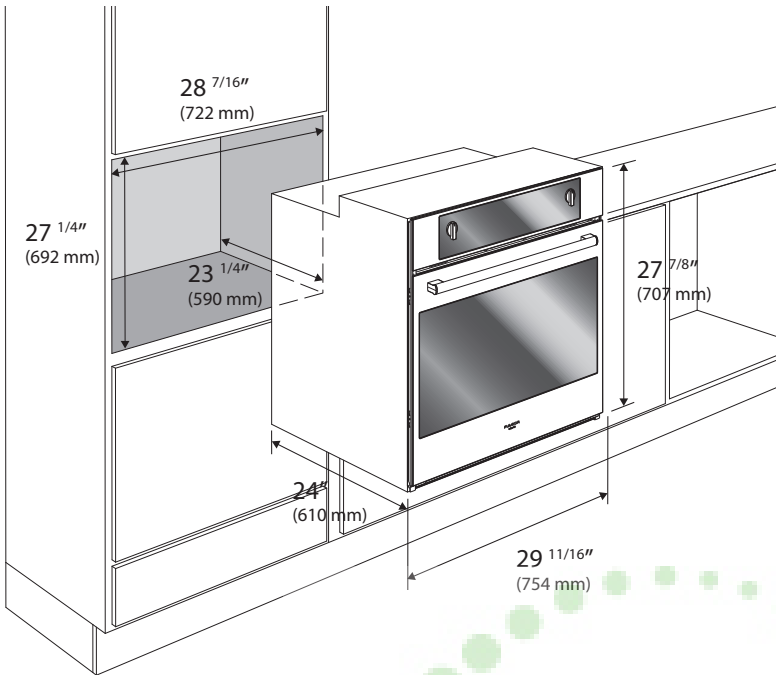

double ovens 30"x 30"

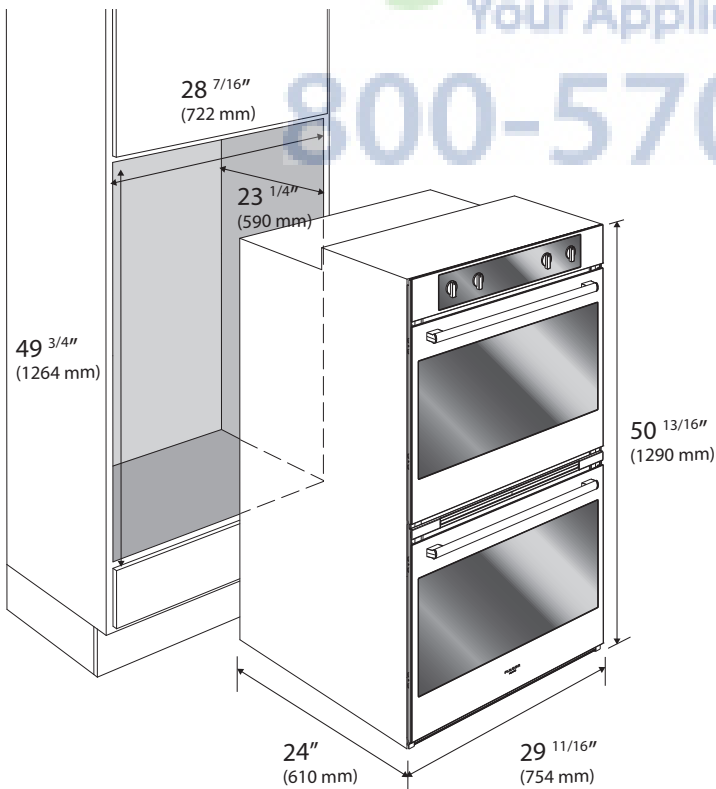

SYMBOLS

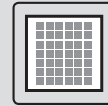

Pyrolytic Self-Clean with automatic door latch

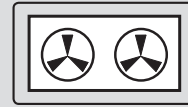

True European Convection Bake (Multi level)



Convection Broil



Convection Roast



Pizza (Lower Convection)



Bake



Broil



Dehydrate



Thaw (Defrost)

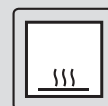

Proof (Warm)

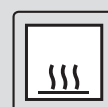

Keep warm (Warm Plus)



Oven Lights



Fast Preheat

AjMadison
Your Appliance Authority™
800-570-3355



Aj Madison
Your Appliance Authority
800-570-3355

Series 600

Single Ovens



F6SP30S1

Dual fan Multifunction pyrolytic oven 30", 600 Series

- Stainless steel
- Electronic controls with intuitive and easy access to the oven's numerous cooking functions
- Pyrolytic Self-Clean with automatic door latch
- Electronic temperature regulation
- 12 cooking functions including "pizza" function
- 3x20W halogen lighting
- English language

Special functions:

- Preset/Last used temperature memory
- Preheat bar (25%, 50%, 75%, 100%)
- Automatic Fast Preheat
- Keyboard Lock
- Child door lock
- Sabbath mode
- 12/24 hours clock format
- °C/F° degree unit

Delivered accessories:

- 2 chromed racks
- Enameled grill set (basin+anti-splash)
- Meat probe
- Telescopic chromed rack

Series 600

Single Ovens



F6SP30W1

Dual fan Multifunction pyrolytic oven 30", 600 Series

- White Colour
- Electronic controls with intuitive and easy access to the oven's numerous cooking functions
- Pyrolytic Self-Clean with automatic door latch
- Electronic temperature regulation
- 12 cooking functions including "pizza" function
- 3x20W halogen lighting
- English language

Special functions:

- Preset/Last used temperature memory
- Preheat bar (25%, 50%, 75%, 100%)
- Automatic Fast Preheat
- Keyboard Lock
- Child door lock
- Sabbath mode
- 12/24 hours clock format
- °C/F° degree unit

Delivered accessories:

- 2 chromed racks
- Enameled grill set (basin+anti-splash)
- Meat probe
- Telescopic chromed rack



AJ Madison
Your Appliances Authority™
800-570-3355

Series 600

Double Ovens

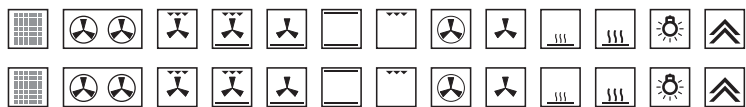

Upper
Oven

Lower
Oven

F6DP30S1

Double Dual Multifunction pyrolytic oven 30", 600 Series

- Stainless steel
- Electronic controls with intuitive and easy access to the oven's numerous cooking functions
- Pyrolytic Self-Clean with automatic door latch
- Electronic temperature regulation
- 12 cooking functions including "pizza" function
- 3x20W halogen lighting for each cavity
- English language

Special functions:

- Preset/Last used temperature memory
- Preheat bar (25%, 50%, 75%, 100%)
- Automatic Fast Preheat
- Keyboard Lock
- Child door lock
- Sabbath mode
- 12/24 hours clock format
- °C/°F degree unit

Delivered upper oven accessories:

- 2 chromed racks
- Enameled grill set(basin+anti-splash)
- Meat probe
- Telescopic chromed rack

Delivered lower oven accessories:

- 2 chromed racks
- Enameled grill set(basin+anti-splash)
- Telescopic chromed rack

Series 600

Double Ovens

F6DP30B1

Double Dual Multifunction pyrolytic oven 30", 600 Series

- Black Colour
- Electronic controls with intuitive and easy access to the oven's numerous cooking functions
- Pyrolytic Self-Clean with automatic door latch
- Electronic temperature regulation
- 12 cooking functions including "pizza" function
- 3x20W halogen lighting for each cavity
- English language

Special functions:

- Preset/Last used temperature memory
- Preheat bar (25%, 50%, 75%, 100%)
- Automatic Fast Preheat
- Keyboard Lock
- Child door lock
- Sabbath mode
- 12/24 hours clock format
- °C/F° degree unit

Delivered upper oven accessories:

- 2 chromed racks
- Enameled grill set(basin+anti-splash)
- Meat probe
- Telescopic chromed rack

Delivered lower oven accessories:

- 2 chromed racks
- Enameled grill set(basin+anti-splash)
- Telescopic chromed rack

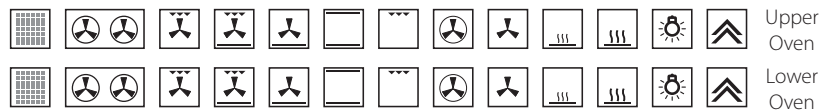

Upper
Oven

Lower
Oven

Series 600

Double Ovens



Upper
Oven

Lower
Oven

F6DP30W1

Double Dual Multifunction pyrolytic oven 30", 600 Series

- White Colour
- Electronic controls with intuitive and easy access to the oven's numerous cooking functions
- Pyrolytic Self-Clean with automatic door latch
- Electronic temperature regulation
- 12 cooking functions including "pizza" function
- 3x20W halogen lighting for each cavity
- English language

Special functions:

- Preset/Last used temperature memory
- Preheat bar (25%, 50%, 75%, 100%)
- Automatic Fast Preheat
- Keyboard Lock
- Child door lock
- Sabbath mode
- 12/24 hours clock format
- °C/°F degree unit

Delivered upper oven accessories:

- 2 chromed racks
- Enameled grill set(basin+anti-splash)
- Meat probe
- Telescopic chromed rack

Delivered lower oven accessories:

- 2 chromed racks
- Enameled grill set(basin+anti-splash)
- Telescopic chromed rack



AjMadison
Your Appliance Authority™
800-570-3355

400 Series

Single Ovens



A sleek European design and flush installation, the 400 series oven shares the same body and soul of the 600 series oven, offering many of the same professional features while providing tremendous value. Available only in a single oven configuration, this series offers an oversized oven capacity, multi pass broil, European convection, concealed bake elements and 8 baking functions; all of which are controlled by an easy to use and extremely reliable control system.

The Athena XS control gives the home chef complete control via easy to use and intuitive controls making this oven a great choice as a primary or secondary oven for a variety of kitchen designs and applications.

SAFETY FEATURE: COOL DOOR

Rest assured, your hands are safe with us.
Our cool-door technology has a proven guarantee

EXTRA LARGE CAVITY

Imagine the efficiency of being able to use multiple levels of a huge oven at once. We consider it an advantage, don't you?

AjMadison
Your Appliance Authority
800-570-3355

TELESCOPIC RACK

Our fully retractable telescopic rack enhances your cooking experience (100%)



DIMENSIONS

single ovens 30"x 30"

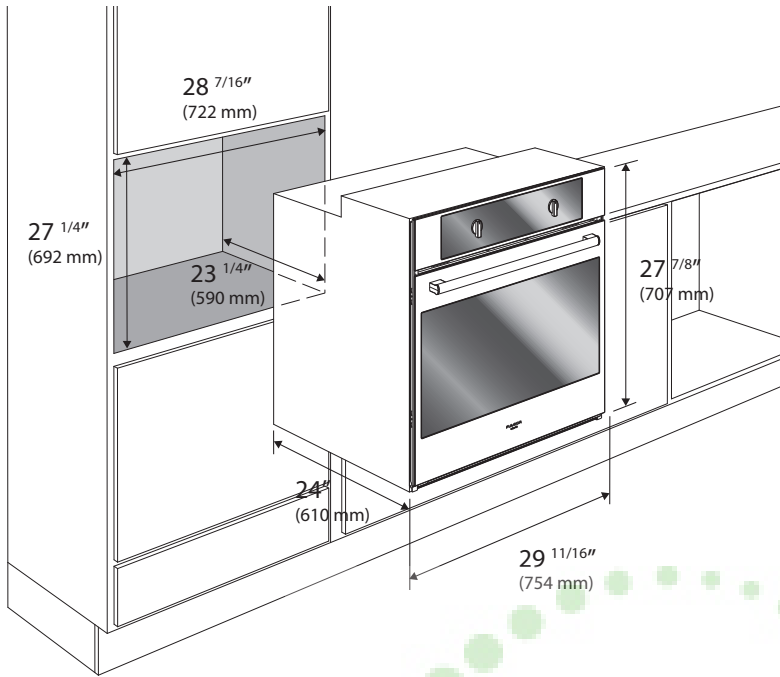

AjMadison
Your Appliance Authority™
800-570-3355

SYMBOLS

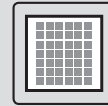

Pyrolytic Self-Clean with automatic door latch



True European Convection Bake



Convection Broil



Bake



Broil



Thaw
(Defrost)



Convection bake
(without ring element)



Oven Lights



AjM
Your Appliances Authority
800-570-3355

Series 400

Single Ovens



F4SP30S1

Multifunction pyrolytic oven 30", 400 Series

- Stainless steel
- Electronic controls with intuitive and easy access to the oven's numerous cooking functions
- Pyrolytic Self-Clean
- Electronic temperature regulation
- 8 cooking functions
- 3x20W halogen lighting
- English language

Special functions:

- 12 hours clock format (AM/PM)
- °C/F° degree unit
- Preheat indication

Delivered accessories:

- 2 chromed racks
- Enameled grill set (basin+anti-splash)

Optional accessories:

- Telescopic chromed rack

F4SP30B1

Multifunction pyrolytic oven 30", 400 Series

- Black Colour
- Electronic controls with intuitive and easy access to the oven's numerous cooking functions
- Pyrolytic Self-Clean
- Electronic temperature regulation
- 8 cooking functions
- 3x20W halogen lighting
- English language

Special functions:

- 12 hours clock format (AM/PM)
- °C/F° degree unit
- Preheat indication

Delivered accessories:

- 2 chromed racks
- Enameled grill set (basin+anti-splash)

Optional accessories:

- Telescopic chromed rack

Series 400

Single Ovens



Series 400

Single Ovens



F4SP30W1

Multifunction pyrolytic oven 30", 400 Series

- White Colour
- Electronic controls with intuitive and easy access to the oven's numerous cooking functions
- Pyrolytic Self-Clean
- Electronic temperature regulation
- 8 cooking functions
- 3x20W halogen lighting
- English language

Special functions:

- 12 hours clock format (AM/PM)
- °C/F° degree unit
- Preheat indication

Delivered accessories:

- 2 chromed racks
- Enameled grill set (basin+anti-splash)

Optional accessories:

- Telescopic chromed rack

AjMadison
Your Appliance Authority™
800-570-3355



AjMadison
Your Appliance Authority
800-570-3355

100 Series

Single Ovens



A standard-setting series with first-class performance.

Many preset cooking functions help you prepare your meals with efficiency and ease. The fastest and most versatile self-clean mode available, featuring automatic door-latch system.

Child safety locks and cool-touch doors protect you and your family from high temperatures while cooking and during the self-clean cycle. 5 broil levels. Smaller cavity dimensions fit in any kitchen and reduce energy consumption while providing ample space for all your cooking needs.

A selection of accessories is available for your convenience.

HALOGEN LIGHTS

Two 20-watt halogen bulbs provide plenty of light for easy viewing



CONCEALED BAKE ELEMENTS

The concealed heating element and large broiler make it possible to cook and save energy at the same time



AjMadison
Your Appliance Authority™
800-570-3355

NEW ITALIAN DESIGN

Combining straightforwardness and ease of use with a clean Italian design, our control panel does not require an engineer to operate



DIMENSIONS



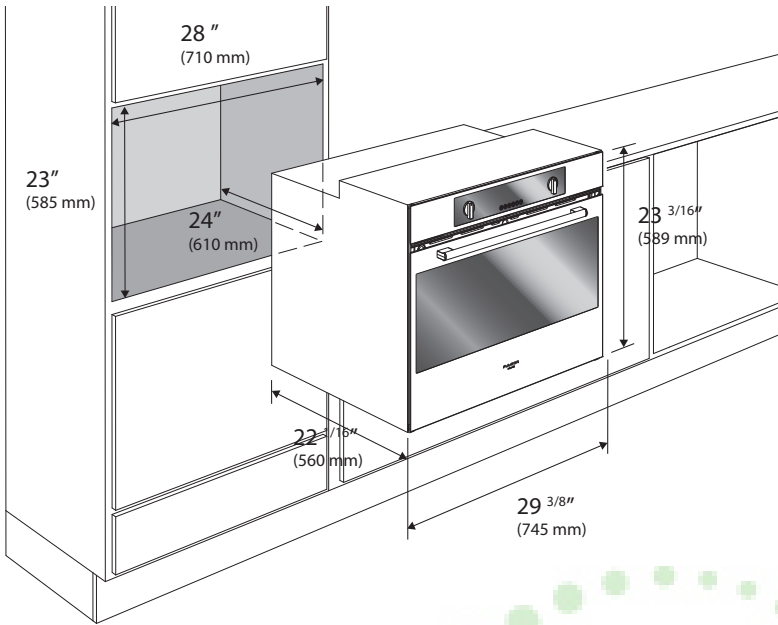



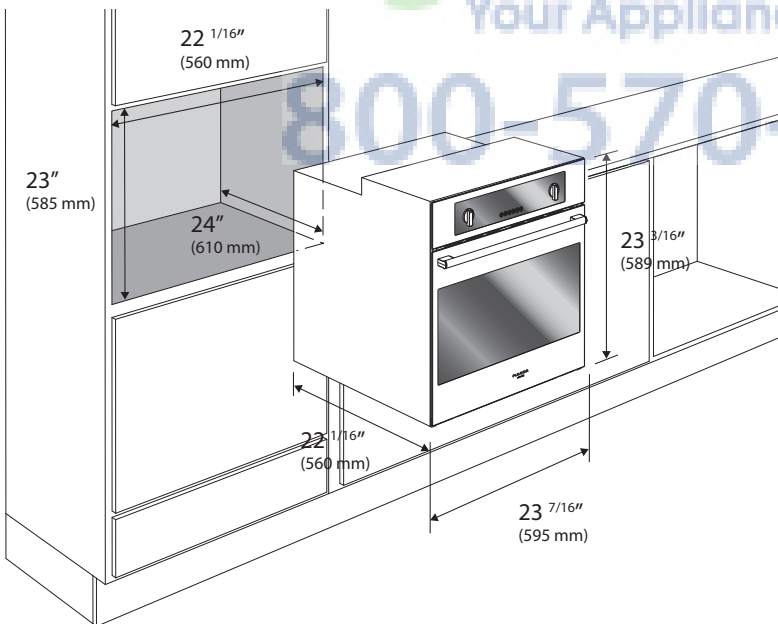



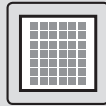

single ovens 30"x 24"



single ovens 24"x 24"



SYMBOLS

-  Pyrolytic Self-Clean with automatic door latch
-  True European Convection Bake
-  Convection Broil
-  Bake
-  Broil
-  Lower Bake
-  Thaw (Defrost)
-  Maxi Broil
-  Dehydrate
-  Convection bake (without ring element)
-  Pizza (Lower Convection)
-  Oven Lights
-  Convection Roast

AjMadison
Your Appliance Authority™
800-570-3355



AjMason
Your Appliance Authority
800-570-3355

Series 100

Single Ovens



F1SP30S2

Multifunction pyrolytic oven 30", 100 Series

- Stainless colour
- Electronic controls
- Rounded handle
- Pyrolytic Self-Clean with automatic door latch
- Electronic temperature regulation
- 7 cooking functions
- 2X20W halogen lighting
- English language

Special functions:

- Manual fast pre-heat
- Child door lock
- Sabbath mode
- 12/24 hours clock format
- °C/°F degree unit

Delivered accessories:

- 2 chromed racks
- Enameled grill set (basin+anti-splash)

Optional accessories:

- Telescopic chromed rack

AjMadison

Your Appliance Authority

800-570-3355

F1SP30S1

Multifunction pyrolytic oven 30", 100 Series

- Stainless colour
- Electronic controls
- Pyrolytic Self-Clean
- Electronic temperature regulation
- 8 cooking functions
- 2X20W halogen lighting
- English language

Special functions:

- 12 hours clock format (AM/PM)
- °C/F° degree unit
- Preheat indication

Delivered accessories:

- 2 chromed racks
- Enameled grill set (basin+anti-splash)

Optional accessories:

- Telescopic chromed rack

Series 100

Single Ovens



AjMadison
Your Appliance Authority™
800-570-3355

Series 100

Single Ovens



F1SP24S1

Multifunction pyrolytic oven 24", 100 Series

- Electronic controls
- Pyrolytic Self-Clean
- Electronic temperature regulation
- 8 cooking functions
- 1X20W halogen lighting
- English language

Special functions:

- 12 hours clock format (AM/PM)
- °C/F° degree unit
- Preheat indication

Delivered accessories:

- 2 chromed racks
- Enameled grill set (basin+anti-splash)

Optional accessories:

- Telescopic chromed rack

AjMadison

Your Appliance Authority™

800-570-3355

F1SM30S1**Convection oven 30", stainless steel, 100 Series**

- Time programmer
- Thermostat temperature regulation
- 8 cooking functions
- 2X20W halogen lighting
- English language

Delivered accessories:

- 2 chromed racks
- Enameled grill set (basin+anti-splash)

Series 100

Single Ovens



AjMadison
Your Appliance Authority™
800-570-3355

Series 100

Single Ovens



F1SM24S1

Convection oven 24", stainless steel, 100 Series

- Time programmer
- Thermostat temperature regulation
- 8 cooking functions
- 1X20W halogen lighting
- English language

Delivered accessories:

- 2 chromed racks
- Enameled grill set (basin+anti-splash)

AjMadison
Your Appliance Authority™
800-570-3355

Accessories & Technical Data

Single & Double Ovens



Useful accessories will help you customize your appliances while giving you ease, efficiency and successful results in your cooking.

The telescopic rack is an indispensable addition to every modern oven.

TELESCOPIC RACKS**FMTR124**

Telescopic rack kit "100" Series
24" Stainless Steel/Chrome

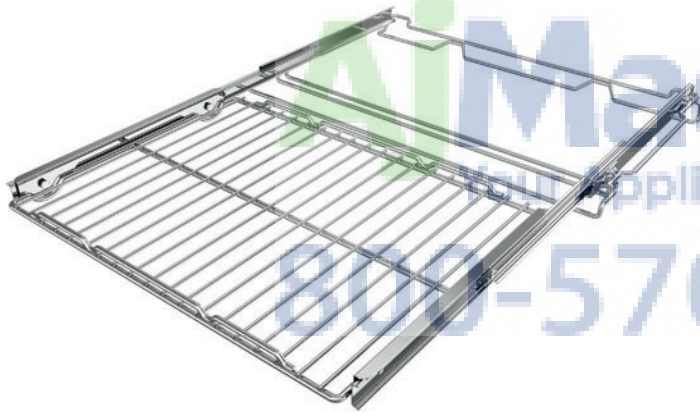
**FMTR130**

Telescopic rack kit "100" Series
30" Stainless Steel/Chrome

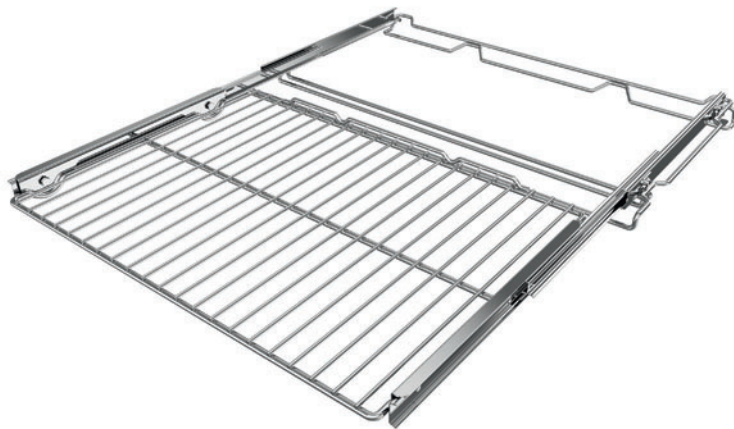
**FMTR630**

Telescopic rack kit "400" and "600" Series
30" Stainless Steel/Chrome

The logo for Madison Appliance Authority, featuring a stylized green 'M' with a dotted arc above it, followed by the word 'Madison' in a large blue font, 'Appliance Authority' in a smaller blue font below it, and the phone number '800-570-3355' in a large blue font at the bottom.



MODEL	F6SP30S1	F6SP30B1	F6SP30W1
Type	PYRO	PYRO	PYRO
Size	30"x30"	30"x30"	30"x30"
Colour	SS	BLACK	WHITE
Stainless Steel Aesthetics	Embossed window profile with bended edges		
Oven Type	Multifunction 2 Fans (True Euro Conv.)	Multifunction 2 Fans (True Euro Conv.)	Multifunction 2 Fans (True Euro Conv.)
Temperature Regulation	Electronic	Electronic	Electronic
Control Panel			
Control type	HAWK3TC - Electronic	HAWK3TC - Electronic	HAWK3TC - Electronic
Clock/Timer Display	Blue Backlight	Blue Backlight	Blue Backlight
Temperature Display	Red LED	Red LED	Red LED
Function Display	Red LED	Red LED	Red LED
Commands	2 Knobs / 6 Touch Keys	2 Knobs / 6 Touch Keys	2 Knobs / 6 Touch Keys
Knobs type	MGH "U" PLASTIC	MGH "U" PLASTIC	MGH "U" PLASTIC
Language	English	English	English
Special Features			
Preset/Last used temperature memory	X	X	X
Preheat bar (25%, 50%, 75%, 100%)	X	X	X
Automatic Fast Preheat	X	X	X
Child Door Lock	X	X	X
Commands Lock	X	X	X
Sabbath mode	X	X	X
12/24 hours clock format	X	X	X
°C/°F degree unit	X	X	X
Oven Door(s)			
Oven Glass Window	Large See Through Glass	Large See Through Glass	Large See Through Glass
Door Cooling System	4 Pane Heat Resistant Glass	4 Pane Heat Resistant Glass	4 Pane Heat Resistant Glass
Door Hinges	Heavy Duty Steady Tilt	Heavy Duty Steady Tilt	Heavy Duty Steady Tilt
Handle style	Stainless Steel Tube d25mm, Plastic terminals	Stainless Steel Tube d25mm, Plastic terminals	Stainless Steel Tube d25mm, Plastic terminals
Oven Cavity			
Net Capacity (cbft)	4.1	4.1	4.1
Cavity Enameling Colour	Grey	Grey	Grey
Rack Positions	6	6	6
Oven Lights	3x20W Halogen	3x20W Halogen	3x20W Halogen
Broil Upper Heating Element	3500 W (240V)	3500 W (240V)	3500 W (240V)
Upper Auxiliary Element Wattage	1032W (240V)	1032W (240V)	1032W (240V)
Concealed Bake Lower Heating Element	3000 W (240V)	3000 W (240V)	3000 W (240V)
Convection Element Wattage	2x1300 W (240V)	2x1300 W (240V)	2x1300 W (240V)
Oven Accessories			
Chromed racks	2	2	2
Enameled Grill set (basin + anti splash)	1	1	1
Telescopic chromed rack	1	1	1
Meat probe	1	1	1
Dimensions/Weight - (In or Lbs)			
Overall dim - width	29 11/16" (754mm)	29 11/16" (754mm)	29 11/16" (754mm)
Overall dim - height	27-7/8" (707mm)	27-7/8" (707mm)	27-7/8" (707mm)
Overall dim - depth	24" (610mm)	24" (610mm)	24" (610mm)
Cutout - width	28 7/16" (722mm)	28 7/16" (722mm)	28 7/16" (722mm)
Cutout - height (min)	27-1/4" (692mm)	27-1/4" (692mm)	27-1/4" (692mm)
Cutout - depth (min)	23-1/4" (590mm)	23-1/4" (590mm)	23-1/4" (590mm)
Power / Ratings (208/240 V, 60 Hz)			
KW/Amps rating at 240V, 60Hz	3.84kW - 16.9Amps	3.84kW - 16.9Amps	3.84kW - 16.9Amps
KW/Amps rating at 208V, 60Hz	3.54kW - 17.5Amps	3.54kW - 17.5Amps	3.54kW - 17.5Amps
Cable + Conduit	X	X	X
Instructions for use			
Use & Care Manual	EN, SP, FR	EN, SP, FR	EN, SP, FR
Installation Manual	EN, SP, FR	EN, SP, FR	EN, SP, FR



MODEL	F6DP30S1	F6DP30SB1	F6DP30W1
Type	PYRO	PYRO	PYRO
Size	30"x30"	30"x30"	30"x30"
Colour	SS	BLACK	WHITE
Stainless Steel Aesthetics	Embossed window profile with bended edges		
Oven Type	Both Multifunction 2 Fans (True Euro Conv.)		
Temperature Regulation	Electronic	Electronic	Electronic
Control Panel			
Control type	HAWK3TC - Electronic	HAWK3TC - Electronic	HAWK3TC - Electronic
Clock/Timer Display	Blue Backlight	Blue Backlight	Blue Backlight
Temperature Display	Red LED	Red LED	Red LED
Function Display	Red LED	Red LED	Red LED
Commands	2 Knobs / 6 Touch Keys	2 Knobs / 6 Touch Keys	2 Knobs / 6 Touch Keys
Knobs type	MGH "U" PLASTIC	MGH "U" PLASTIC	MGH "U" PLASTIC
Language	English	English	English
Special Features			
Preset/Last used temperature memory	X	X	X
Preheat bar (25%, 50%, 75%, 100%)	X	X	X
Automatic Fast Preheat	X	X	X
Child Door Lock	X	X	X
Commands Lock	X	X	X
Sabbath mode	X	X	X
12/24 hours clock format	X	X	X
°C/°F degree unit	X	X	X
Oven Door(s)			
Oven Glass Window	Large See Through Glass	Large See Through Glass	Large See Through Glass
Door Cooling System	4 Pane Heat Resistant Glass	4 Pane Heat Resistant Glass	4 Pane Heat Resistant Glass
Door Hinges	Heavy Duty Steady Tilt	Heavy Duty Steady Tilt	Heavy Duty Steady Tilt
Handle style	Stainless Steel Tube d25mm, Plastic terminals	Stainless Steel Tube d25mm, Plastic terminals	Stainless Steel Tube d25mm, Plastic terminals
Oven Cavity			
Net Capacity (cbft)	4.1	4.1	4.1
Cavity Enameling Colour	Grey	Grey	Grey
Rack Positions	6	6	6
Oven Lights	3x20W Halogen	3x20W Halogen	3x20W Halogen
Broil Upper Heating Element	3500 W (240V)	3500 W (240V)	3500 W (240V)
Upper Auxiliary Element Wattage	1032W (240V)	1032W (240V)	1032W (240V)
Concealed Bake Lower Heating Element	3000 W (240V)	3000 W (240V)	3000 W (240V)
Convection Element Wattage	2x1300 W (240V)	2x1300 W (240V)	2x1300 W (240V)
Oven Accessories			
Chromed racks	2 per cavity	2 per cavity	2 per cavity
Enameled Grill set (basin + anti splash)	1 per cavity	1 per cavity	1 per cavity
Telescopic chromed rack	1 per cavity	1 per cavity	1 per cavity
Meat probe	Upper Oven Only	Upper Oven Only	Upper Oven Only
Dimensions/Weight - (In or Lbs)			
Overall dim - width	29 11/16" (754mm)	29 11/16" (754mm)	29 11/16" (754mm)
Overall dim - height	50 13/16" (1290mm)	50 13/16" (1290mm)	50 13/16" (1290mm)
Overall dim - depth	24" (610mm)	24" (610mm)	24" (610mm)
Cutout - width	28 7/16" (722mm)	28 7/16" (722mm)	28 7/16" (722mm)
Cutout - height (min)	49 3/4" (1264mm)	49 3/4" (1264mm)	49 3/4" (1264mm)
Cutout - depth (min)	23 1/4" (590mm)	23 1/4" (590mm)	23 1/4" (590mm)
Power / Ratings (208/240 V, 60 Hz)			
KW/Amps rating at 240V, 60Hz	7.68kW - 33.8Amps	7.68kW - 33.8Amps	7.68kW - 33.8Amps
KW/Amps rating at 208V, 60Hz	6.48kW - 32.4Amps	6.48kW - 32.4Amps	6.48kW - 32.4Amps
Cable + Conduit	X	X	X
Instructions for use			
Use & Care Manual	EN, SP, FR	EN, SP, FR	EN, SP, FR
Installation Manual	EN, SP, FR	EN, SP, FR	EN, SP, FR

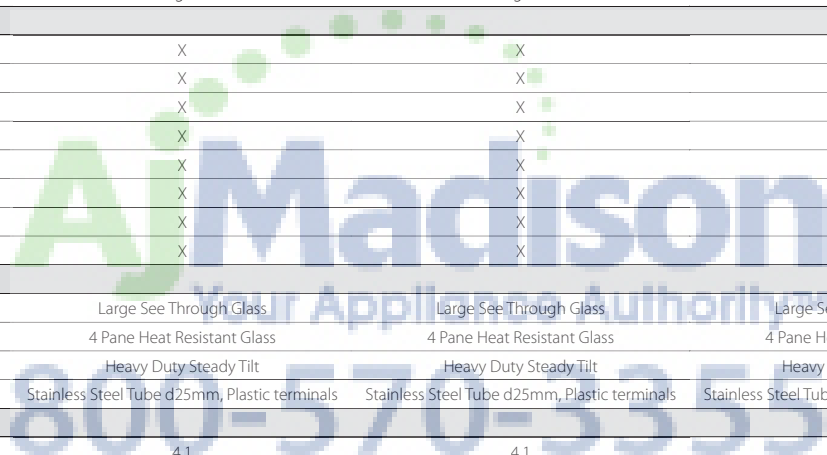



MODEL	F4SP30S1	F4SP30B1	F4SP30W1
Type	PYRO	PYRO	PYRO
Size	30"x30"	30"x30"	30"x30"
Colour	SS	BLACK	WHITE
Oven Type	Multifunction (True Euro Conv.)	Multifunction (True Euro Conv.)	Multifunction (True Euro Conv.)
Temperature Regulation	Electronic	Electronic	Electronic
Control Panel			
Control type	Athena XS - Electronic	Athena XS - Electronic	Athena XS - Electronic
Clock/Timer Display	Red LED	Red LED	Red LED
Commands	2 Knobs	2 Knobs	2 Knobs
Knobs type	MGH "U" PLASTIC	MGH "U" PLASTIC	MGH "U" PLASTIC
Language	English	English	English
Special Features			
Manual Fast Preheat			
Child Door Lock			
Sabbath mode			
12/24 hours clock format			
°C/°F degree unit	X	X	X
Oven Door(s)			
Oven Glass Window	Large See Through Glass	Large See Through Glass	Large See Through Glass
Door Cooling System	4 Pane Heat Resistant Glass	4 Pane Heat Resistant Glass	4 Pane Heat Resistant Glass
Door Hinges	Heavy Duty Steady Tilt	Heavy Duty Steady Tilt	Heavy Duty Steady Tilt
Handle style	Tubular Steel	Tubular Steel	Tubular Steel
Oven Cavity			
Net Capacity (cbft)	4.3	4.3	4.3
Cavity Enameling Colour	Grey	Grey	Grey
Rack Positions	6	6	6
Oven Lights	3x20W Halogen	3x20W Halogen	3x20W Halogen
Broil Upper Heating Element	3100 W (240V)	3100 W (240V)	3100 W (240V)
Upper Auxiliary Element Wattage	1032W (240V)	1032W (240V)	1032W (240V)
Concealed Bake Lower Heating Element	1400 W (240V)	1400 W (240V)	1400 W (240V)
Lower Auxiliary Element Wattage	600W (240V)	600W (240V)	600W (240V)
Convection Element Wattage	2500 W (240V)	2500 W (240V)	2500 W (240V)
Oven Accessories			
Chromed racks	2	2	2
Enameled Grill set (basin + anti splash)	1	1	1
Telescopic chromed rack	Optional	Optional	Optional
Dimensions/Weight - (In or Lbs)			
Overall dim - width	29 11/16" (754mm)	29 11/16" (754mm)	29 11/16" (754mm)
Overall dim - height	27-7/8" (707mm)	27-7/8" (707mm)	27-7/8" (707mm)
Overall dim - depth	24" (610mm)	24" (610mm)	24" (610mm)
Cutout - width	28 7/16" (722mm)	28 7/16" (722mm)	28 7/16" (722mm)
Cutout - height (min)	27-1/4" (692mm)	27-1/4" (692mm)	27-1/4" (692mm)
Cutout - depth (min)	23-1/4" (590mm)	23-1/4" (590mm)	23-1/4" (590mm)
Power / Ratings (208/240 V, 60 Hz)			
KW/Amps rating at 240V, 60Hz	3.7kW - 16.1Amps	3.7kW - 16.1Amps	3.7kW - 16.1Amps
KW/Amps rating at 208V, 60Hz	3.49kW - 17.1Amps	3.49kW - 17.1Amps	3.49kW - 17.1Amps
Cable + Conduit	X	X	X
Instructions for use			
Use & Care Manual	EN, SP, FR	EN, SP, FR	EN, SP, FR
Installation Manual	EN, SP, FR	EN, SP, FR	EN, SP, FR



MODEL	F1SP30S2	F1SP30S1	F1SP24S1	F1SM30S1	F1SM24S1
Type	PYRO	PYRO	PYRO	NORMAL	NORMAL
Size	30"x24"	30"x24"	24"	30"x24"	24"
Colour	SS	SS	SS	SS	SS
Oven Type	Multifunction (True Euro Conv.)	Multifunction (True Euro Conv.)	Multifunction (True Euro Conv.)	Convection	Convection
Temperature Regulation	Electronic	Electronic	Electronic	Thermostat	Thermostat
Control Panel					
Control type	HAWK2 - Electronic	Athena XS - Electronic	Athena XS - Electronic	Time Programmer	Time Programmer
Clock/Timer Display	Blue/Red LED	Red LED	Red LED	Red Led	Red Led
Commands	2 Knobs / 8 Buttons	2 Knobs	2 Knobs	2 Knobs / 6 Buttons	2 Knobs / 6 Buttons
Knobs type	MGH "U" PLASTIC	MGH "U" PLASTIC	MGH "U" PLASTIC	MGH "U" PLASTIC	MGH "U" PLASTIC
Language	English	English	English	English	English
Special Features					
Manual Fast Preheat	X				
Child Door Lock	X				
Sabbath mode	X				
12/24 hours clock format	X				
°C/°F degree unit	X	X	X		
Oven Door(s)					
Oven Glass Window	Large See Through Glass	Large See Through Glass	Large See Through Glass	Large See Through Glass	Large See Through Glass
Door Cooling System	4 Pane Heat Resistant Glass	4 Pane Heat Resistant Glass	4 Pane Heat Resistant Glass	3 Pane Heat Resistant Glass	3 Pane Heat Resistant Glass
Door Hinges	Heavy Duty Steady Tilt	Heavy Duty Steady Tilt	Heavy Duty Steady Tilt	Heavy Duty Steady Tilt	Heavy Duty Steady Tilt
Handle style	Rounded Stainless Steel	Tubular Steel	Rounded Stainless Steel	Tubular Steel	Tubular Steel
Oven Cavity					
Net Capacity (cbft)	2.78	2.78	2.2	2.78	2.2
Cavity Enameling Colour	Grey	Grey	Grey	Grey	Grey
Rack Positions	4	4	4	4	4
Oven Lights	2x20W Halogen	2x20W Halogen	1x20W Halogen	2x20W Halogen	1x20W Halogen
Broil Upper Heating Element	3500 W (240V)	3100 W (240V)	2000 W (240V)	3100 W (240V)	2000W (240V)
Upper Auxiliary Element Wattage	1032W (240V)	1032W (240V)	1000W (240V)	1032W (240V)	1000W (240V)
Ce concealed Bake Lower Heating Element	3000 W (240V)	1400 W (240V)	1200W (240V)	2100 W (240V)	1200W (240V)
Lower Auxiliary Element Wattage		600W (240V)	400W (240V)		
Convection Element Wattage	2500 W (240V)	2500 W (240V)	2500 W (240V)		
Oven Accessories					
Chromed racks	2	2	2	2	2
Enameled Grill set (basin + anti splash)	1	1	1	1	1
Telescopic chromed rack		Optional	Optional		
Dimensions/Weight - (In or Lbs)					
Overall dim - width	29 3/8" (745mm)	29 3/8" (745mm)	23 7/16" (595mm)	29 3/8" (745mm)	23 7/16" (595mm)
Overall dim - height	23 3/16" (589mm)	23 3/16" (589mm)	23 3/16" (589mm)	23 3/16" (589mm)	23 3/16" (589mm)
Overall dim - depth	22 1/16" (560mm)	22 1/16" (560mm)	22 1/16" (560mm)	22 1/16" (560mm)	22 1/16" (560mm)
Cutout - width	28" (710mm)	28" (710mm)	22 1/16" (560mm)	28" (710mm)	22 1/16" (560mm)
Cutout - height (min)	23" (585mm)	23" (585mm)	23" (585mm)	23" (585mm)	23" (585mm)
Cutout - depth (min)	24" (610mm)	24" (610mm)	24" (610mm)	24" (610mm)	24" (610mm)
Power / Ratings (208/240 V, 60 Hz)					
KW/Amps rating at 240V, 60Hz	3.625kW - 15.6Amps	3.625kW - 15.6Amps	2.5kW - 10.42Amps	3.625kW - 15.6Amps	3050W/12,7Amps approx.
KW/Amps rating at 208V, 60Hz	3.529kW - 17.4Amps	3.529kW - 17.4Amps	2.345kW - 11.3Amps	2.720kW - 11.4Amps	2300W/9,5 Amps approx.
Cable + Conduit	X	X	X	X	X
Instructions for use					
Use & Care Manual	EN, SP, FR	EN, SP, FR	EN, SP, FR	EN, SP, FR	EN, SP, FR
Installation Manual	EN, SP, FR	EN, SP, FR	EN, SP, FR	EN, SP, FR	EN, SP, FR



AjMadison
Your Appliance Authority™
800-570-3355



Cooktops



Fulgor Milano cooktops embody Italian elegance and design while offering the quality and durability expected from one of Europe's leading manufacturers of built in cooking appliances.

Nothing is compromised in the performance of our products. Born from a culture of cooking that is world renowned, our customers should not expect less.

You will be the envy of your guests with your beautiful Italian appliance, which may inspire you to take your culinary skills to new elevations.

The shallow design of our cook tops allow kitchen designers to optimize space, providing the greatest flexibility possible for a variety of installation possibilities.

With a Fulgor Milano cooktop, your dream kitchen will become a reality.





600 Series

Induction Cooktops



Our 600 series induction cooktops follow the same design criteria of all our Fulgor-Milano products; style, function, and performance are at the heart of this product.

Like our radiant touch cooktops our induction units are finished off with a subtle yet elegant aluminum trim that exudes luxury, while offering all of the features you would expect from a premium cooking appliance. Our induction cook tops offer the power and control of a gas cooktop with the speed and clean-ability of a radiant cooktop, these cooktops give you the best of both worlds. From tempering fine chocolate to braising a classic osso bucco, to bringing a 15 quart stock pot to boil in minutes, the possibilities are endless with our induction technology.



FRAME

Aluminum frame stainless steel color protects the glass edges from damage

ELECTRONIC CONTROL

State-of-the-art "Peacock" control. LED displays cooking level. Booster function and low-power settings for accuracy

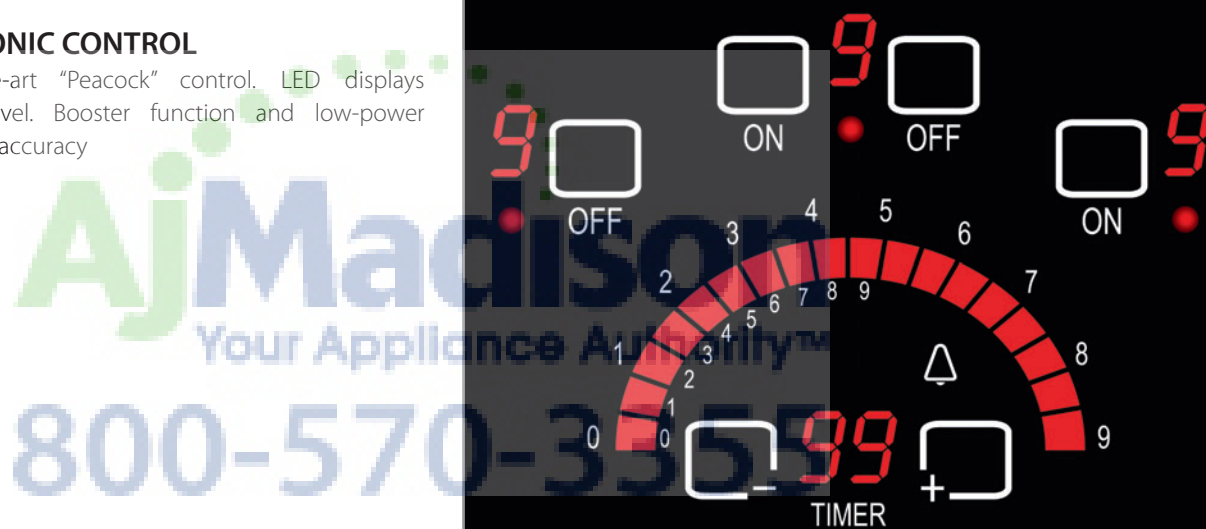

INDUCTION

Heating only the area beneath the pot means cooking softly without compromise. The exact amount of energy needed to heat the pan--no more, no less!



PERFORMANCES OF INDUCTION COOKING

- **High efficiency**

Induction is the most efficient technology available today for cooking. The heat is transferred directly to the iron component in the bottom of the cooking vessel, without loss of energy

- **Reduced heating times**

Induction is 30% to 50% faster compared with other existing cooking technology

- **Low surface temperature**

The glass surface is heated from contact with cooking vessels. Because of this, surface temperatures are lower than those of traditional glass-ceramic cooktops. Glass is a non-stick surface, making cleaning easy

- **Pan detection**

The system detects the presence of cookware over a cooking zone, stopping automatically and cooling down mere seconds after a pan is removed. It can even distinguish between types of pans

- **Safety**

The system detects only vessels having minimum pan diameter; it does not detect small items like utensils that may accidentally be left on the cooktop.

Control lock prevents unintentional activation

HOW DOES INDUCTION COOKING WORK?

Every cooking zone consists of a copper coil (inductor) driven by an electronic system that can generate a high-frequency current in order to induce an electromagnetic field.

Some ferrite (material with a very high magnetic permeability) elements located under the inductor form a loop of magnetic flux (red lines in the picture) with the bottom of the cooking vessel (it must be made with ferro-magnetic material).

The lines of force of the electromagnetic field induce in the bottom of the pot strong eddy currents which generate a large amount of heat

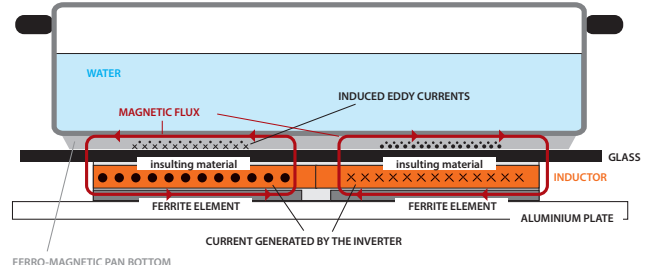

DIMENSIONS

cooktops 36"

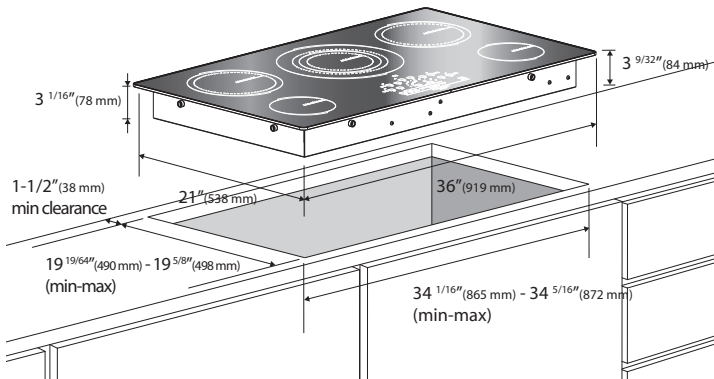

cooktops 30"

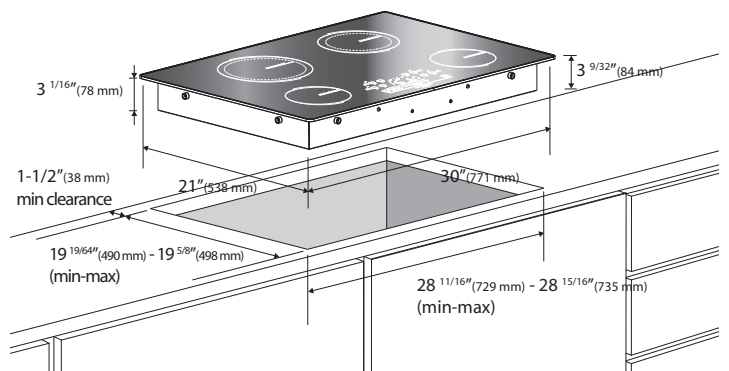



J Madison
Your Appliance Authority™
800-570-3355



At Madison
Your Appliance Authority™
800-570-3355

Series 600

Induction Cooktops



F6IT36S1

Induction cooktop 36", with aluminum frame stainless steel color and glass ceramic, 600 Series

- Slide touch control for power setting
- "Peacock Tail" Bar for power indication
- 5 Digital display for power level indication
- Low temperature electronic control for delicate cooking
- Command Lock
- Booster/Fast boil function
- Hot Surface indication and residual heat indication
- Timer display with 5+1 timers functions and acoustic buzzer
- Failure Codes indication

Front Left Zone

- Size 6"
- Power 1200W
- Booster 1400W

Rear Left Zone

- Size 8"
- Power 2200W
- Booster 3000W

Central Zone (double)

- Size 11" / 7"
- Power 2650W/1800W
- Booster 3600W/2800W

Rear Right Zone

- Size 8"
- Power 2200W
- Booster 3000W

Front Right Zone

- Size 6"
- Power 1200W
- Booster 1400W

Special features:

- Pan Detection System
- Special Big Double zone
- Cooling fan system

Series 600

Induction Cooktops



AjMadison
Your Appliance Authority™

800-570-3355

F6IT30S1

Induction cooktop 30", with aluminum frame stainless steel color and glass ceramic, 600 Series

- Slide touch control for power setting
- "Peacock Tail" Bar for power indication
- 4 Digital display for power level indication
- Low temperature electronic control for delicate cooking
- Command Lock
- Booster/Fast boil function
- Hot Surface indication and residual heat indication
- Timer display with 4+1 timers functions and acoustic buzzer
- Failure Codes indication

Front Left Zone

- Size 6"
- Power 1200W
- Booster 1400W

Rear Left Zone

- Size 8"
- Power 2200W
- Booster 3000W

Rear Right Zone

- Size 7"
- Power 1800W
- Booster 2800W

Front Right Zone

- Size 6"
- Power 1200W
- Booster 1400W

Special features:

- Pan Detection System
- Cooling fan system

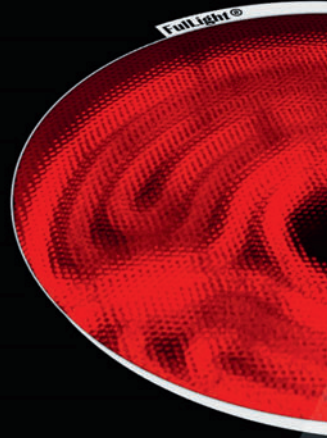

AjMadison
 Your Appliance Authority™
 800-570-3355



600 Series

Radiant Touch Cooktops



Beautiful intuitive controls designed with elegance and precision. Radiant touch cooktops deliver quick and reliable performance with maximum flexibility. Touch controls with patented Peacock control sliding bar for power-level selection and fast boil with automatic power reduction.

FRAME

Aluminum frame stainless steel color: Sophisticated and functional!

ELECTRONIC CONTROL

Fine-tuning of the lower temperatures plus timer function is standard with our "Peacock" tail control. Slide touch bar for continuous setting



HEATING ELEMENT

Trademark FullLight® radiant heating elements provide quick, reliable and evenly distributed heat for more consistent cooking.

Our premium triple burner, offered in the 36" and 30" cooktop, ensures complete flexibility

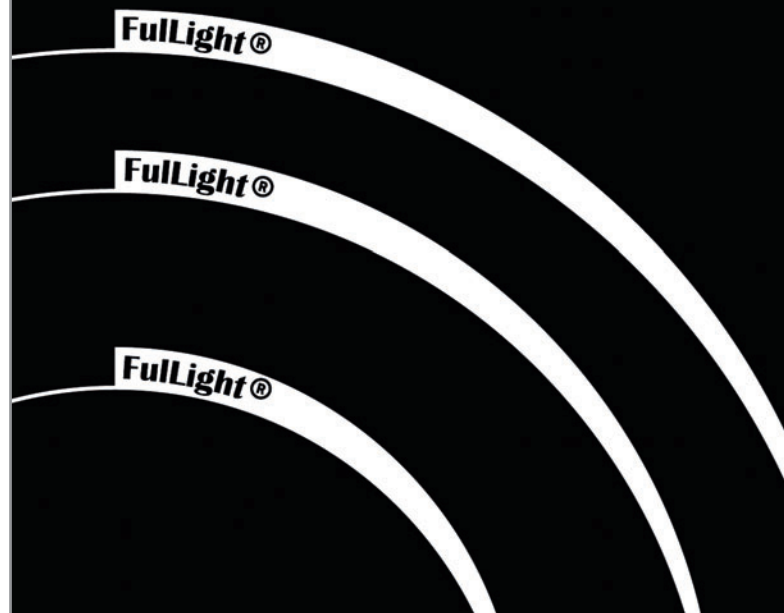

DIMENSIONS

cooktops 36"

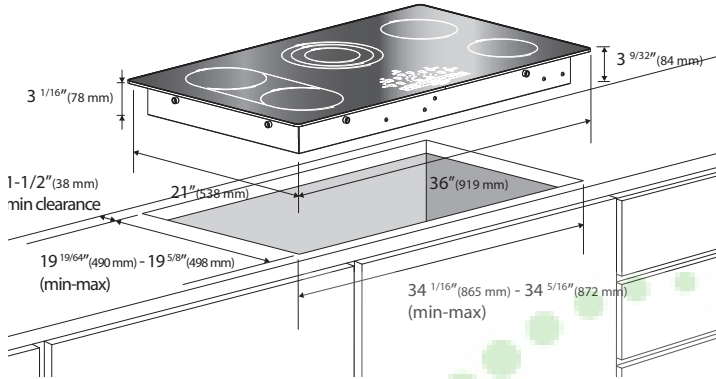

cooktops 30"

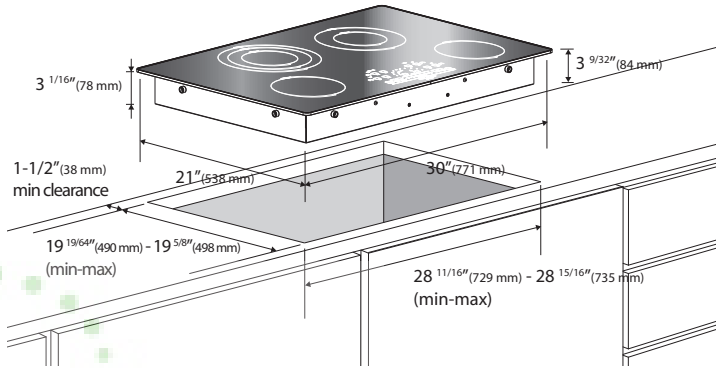

cooktops 24"

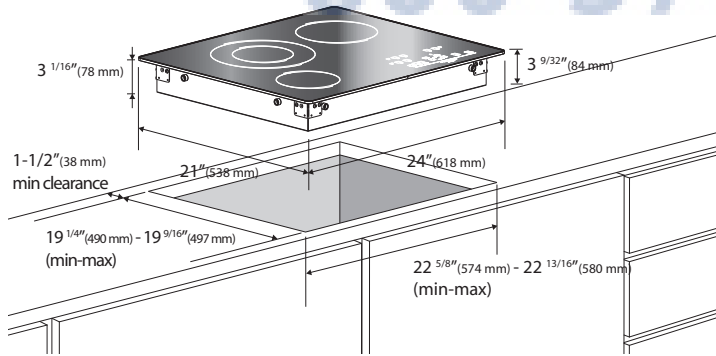

800-570-3355



AjMadison
Your Appliance Authority
800-570-3355

Series 600

Radiant Touch Cooktops



AjMadison
Your Appliance Authority™

800-570-3355

F6RT36S1

Electric radiant cooktop 36", with aluminum frame stainless steel color and glass ceramic, 600 Series

- Slide touch control for power setting
- "Peacock Tail" Bar for power indication
- 5 Digital display for power level indication
- Low temperature electronic control for delicate cooking
- Command Lock
- Automatic Fast Boil function
- Hot Surface indication and residual heat indication
- Timer display with 5+1 timers functions and acoustic buzzer
- Failure Codes indication

Front Left Zone

- Size 7"
- Power 1800W

Bridge Element

- Power 800W

Rear Left Zone

- Size 8"
- Power 1800W

Central Zone

- Size 9" / 7" / 5"
- Power 2500W / 1600W / 800W

Rear Right Zone

- Size 7"
- Power 1800W

Front Right Zone

- Size 6"
- Power 1200W

Series 600

Radiant Touch Cooktops



AjMadison
Your Appliance Authority™

800-570-3355

F6RT30S1

Electric radiant cooktop 30", with aluminum frame stainless steel color and glass ceramic, 600 Series

- "Peacock Tail" Bar for power indication
- 4 Digital display for power level indication
- Low temperature electronic control for delicate cooking
- Command Lock
- Automatic Fast Boil function
- Hot Surface indication and residual heat indication
- Timer display with 4+1 timers functions and acoustic buzzer
- Failure Codes indication

Front Left Zone

- Size 6"
- Power 1200W

Rear Left Zone

- 9" / 7" / 5"
- Power 2500W / 1600W / 800W

Rear Right Zone

- Size 8" / 5"
- Power 2200W / 1600W / 800W

Front Right Zone

- Size 6"
- Power 1200W

Series 600

Radiant Touch Cooktops



AjMadison
Your Appliance Authority™

800-570-3355

F6RT24S1

Electric radiant cooktop 24", with aluminum frame stainless steel color and glass ceramic, 600 Series

- 3 Digital display for power level indication
- Low temperature electronic control for delicate cooking
- Command Lock
- Automatic Fast Boil function
- Hot Surface indication and residual heat indication
- Timer display with 1 timer functions and acoustic buzzer
- Failure Codes indication

Front Left Zone

- Size 5" 1/2
- Power 1200W

Rear Left Zone

- 8" / 5"
- Power 2200W / 800W

Rear Right Zone

- Size 7"
- Power 1800W



AjMadison
Your Appliance Authority™
800-570-3355

300 Series

Radiant Cooktops



Our 300 series cooktops offer the same elegant European design and family line as our radiant touch and induction cooktops but in a package that offers great value and performance to the consumer.

The manual controls are reliable, accurate and continue to be the most user friendly of all control systems available today. Even the most discerning cooks will be impressed with the functionality and performance of this mainstay. Like all Fulgor-Milano cooktops the 300 series offers a shallow profile for countless installation options.



DESIGN

Maintaining style continuity throughout the line, our knob control design ensures clarity and ease of use

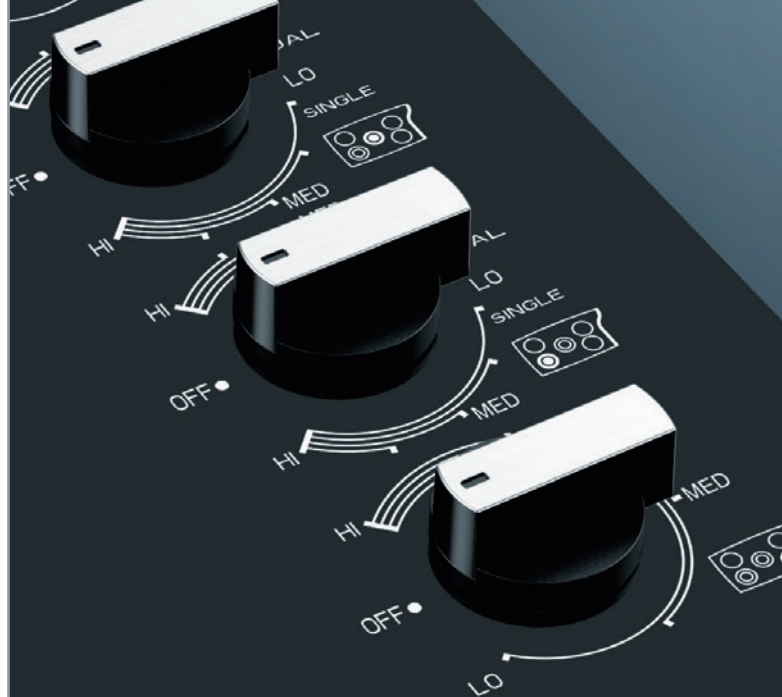

HEATING ELEMENT

Trademark FullLight® radiant heating elements provide quick, reliable and evenly distributed heat for more consistent cooking



AjMadison
Your Appliance Authority™
800-570-3355

PREMIUM GLASS

World leader in premium ceramic glass for the appliance industry, using only the finest material and superior processes



DIMENSIONS

cooktops 36"

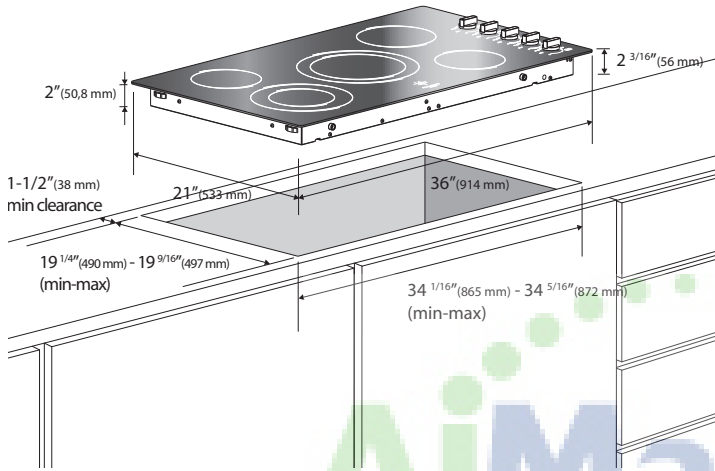

cooktops 30"

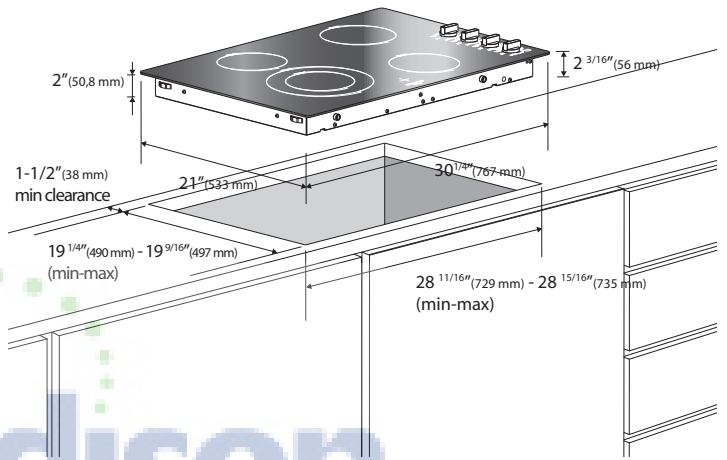

cooktops 24"

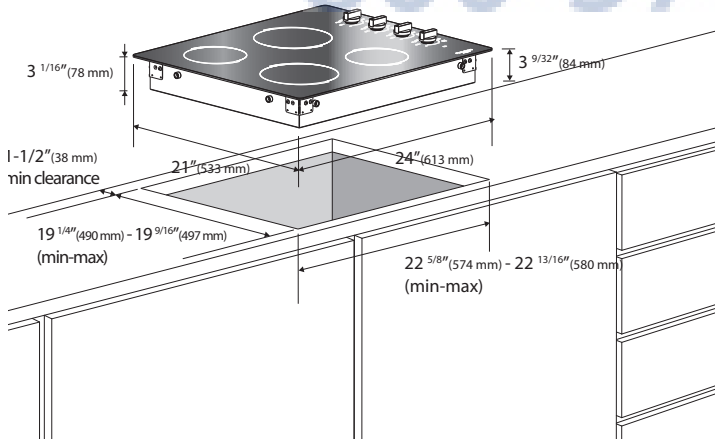

cooktops 24" with frame

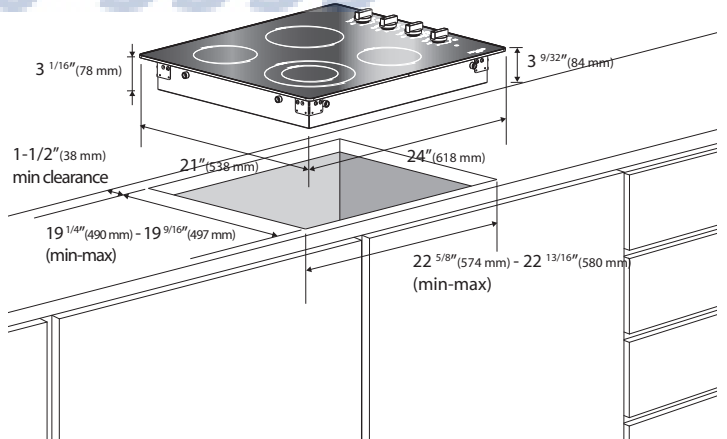

AjMadison
Your Appliance Authority™
800-570-3355



AJ Madison
Your Appliance Authority™
800-570-3355



AjMadison
Your Appliance Authority™
800-570-3355

Series 300

Radiant Cooktops

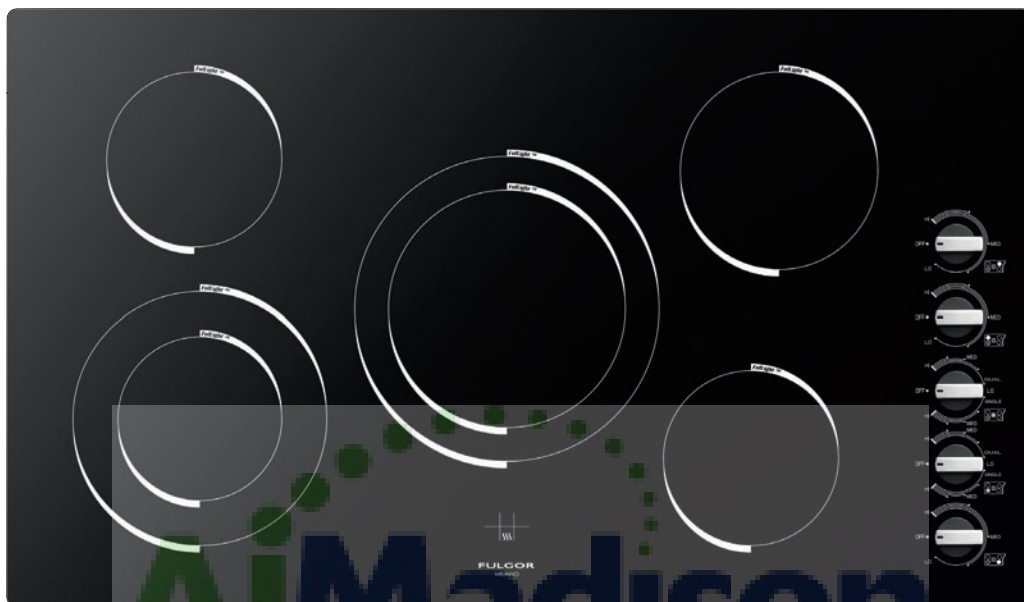

AjMadison
Your Appliance Authority™

800-570-3355

F3RK36B1

Electric radiant cooktop 36", in glass ceramic, 300 Series

- 5 knobs for power level setting
- Hot Surface indicator
- Residual heat indication

Front Left Zone

- Size 9" / 6"
- Power 2500W / 1100W

Rear Left Zone

- Size 6"
- Power 1200W

Central Zone

- Size 11" / 8"
- Power 2700W / 1800W

Rear Right Zone

- Size 7"
- Power 1800W

Front Right Zone

- Size 6"
- Power 1200W

Series 300

Radiant Cooktops

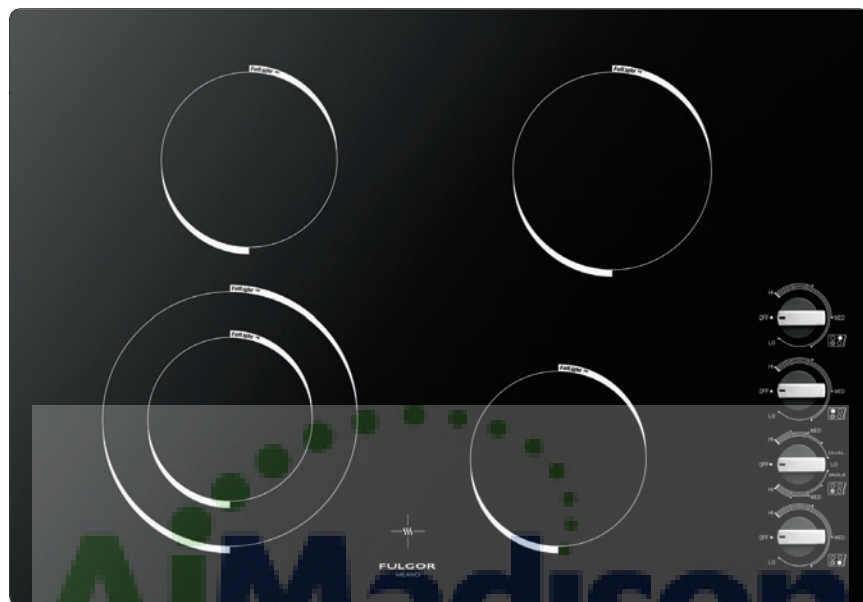

AjMadison
Your Appliance Authority™

800-570-3355

F3RK30B1

Electric radiant cooktop 30", in glass ceramic, 300 Series

- 4 knobs for power level setting
- Hot Surface indicator
- Residual heat indication

Front Left Zone

- Size 9" / 6"
- Power 2500W / 1100W

Rear Left Zone

- Size 6"
- Power 1200W

Rear Right Zone

- Size 7"
- Power 1800W

Front Right Zone

- Size 6"
- Power 1200W

Series 300

Radiant Cooktops

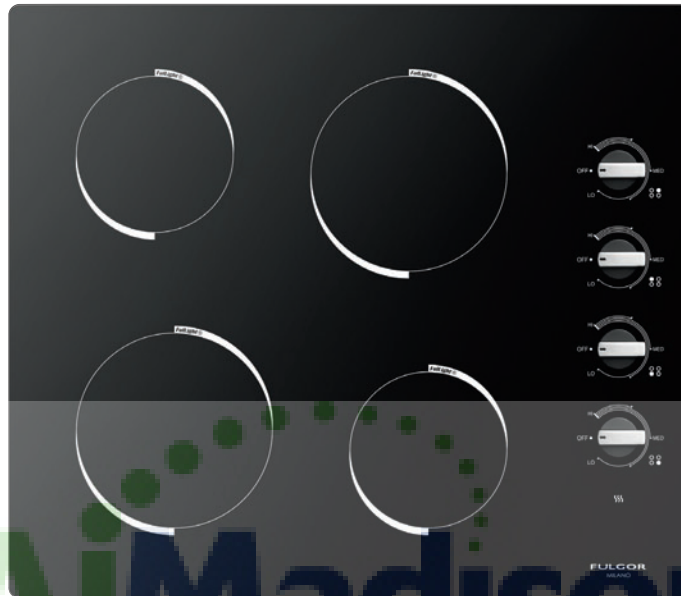

AjMadison
Your Appliance Authority™

800-570-3355

F3RK24B1

Electric radiant cooktop 24", in glass ceramic, 300 Series

- 4 knobs for power level setting
- Hot Surface indicator
- Residual heat indication

Front Left Zone

- Size 7"
- Power 1800W

Rear Left Zone

- Size 5 1/2"
- Power 1200W

Rear Right Zone

- Size 7"
- Power 1800W

Front Right Zone

- Size 5 1/2"
- Power 1200W

Series 300

Radiant Cooktops



AjMadison
Your Appliance Authority™
800-570-3355

F3RK24S1

Electric radiant cooktop 24", with aluminum frame stainless steel color and glass ceramic, 300 Series

- 4 knobs for power level setting
- Hot Surface indicator
- Residual heat indication

Front Left Zone

- Size 7 3/4" / 4 3/4"
- Power 1900W / 800W

Rear Left Zone

- Size 5 1/2"
- Power 1200W

Rear Right Zone

- Size 7"
- Power 1800W

Front Right Zone

- Size 5 1/2"
- Power 1200W

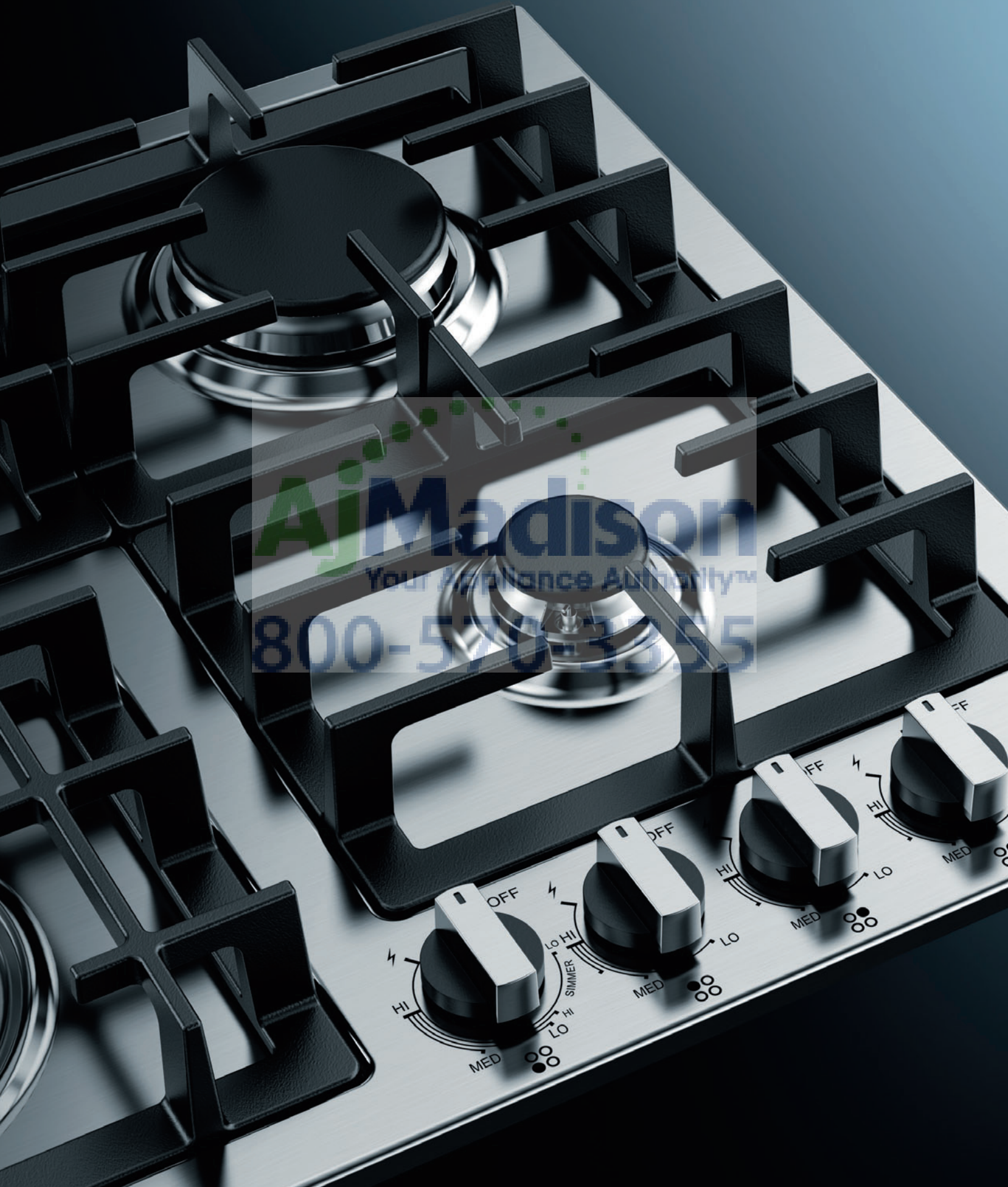

AjMadison
Your Appliance Authority™
800-570-3355

400 Series

Gas Cooktops



The 400 series "Largo" cooktops utilize the most advanced technology available and combine this with a classic Italian design, resulting in a cooktop that not only performs magnificently but also looks spectacular.

A design that lends itself to countless application possibilities, the 400 series cooktops also take the consumers cooking and maintenance needs into consideration. All grates are separated in sizes that make them easy to handle and remove for cleaning. The burners are well orientated to ease of use, with unique configurations like a wok burner and fifth burner on a 30" unit, making this cook top one of the most versatile in the category.

Explore the Largo cooktop family and enjoy the possibilities; buon appetito!

CLASSIC DESIGN

Italian design principles inform the style, function and performance of this series, creating a classic yet versatile cooktop

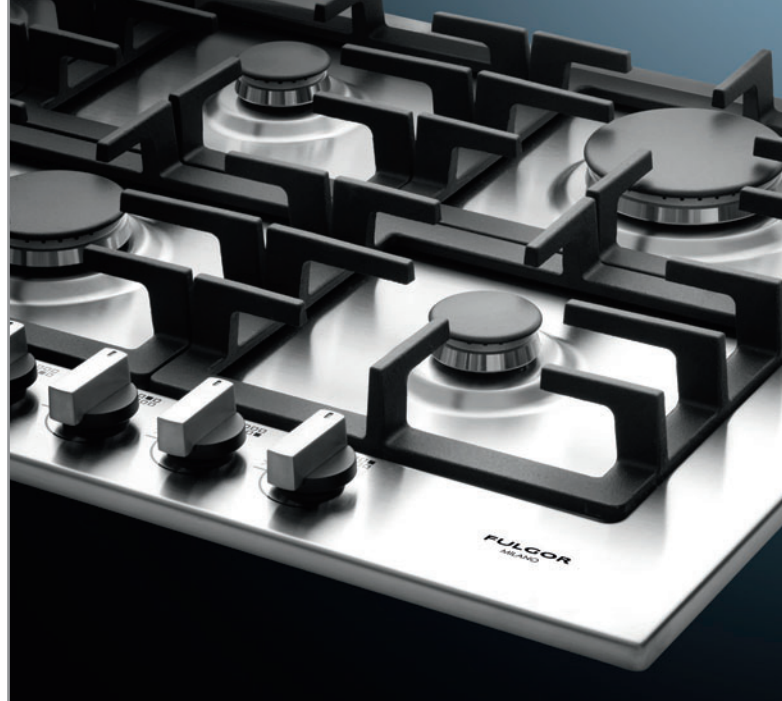

DUAL BURNER

Fulgor-Milano uses a dual-flame European-style sealed burner to deliver a wide range of heat



AjMadison
Your Appliance Authority™
800-570-3355

EUROPEAN SEALED BURNERS

Designed with only two removable parts, our sealed burners keep spills from leaking inside the cooktop



DIMENSIONS

cooktops 42"

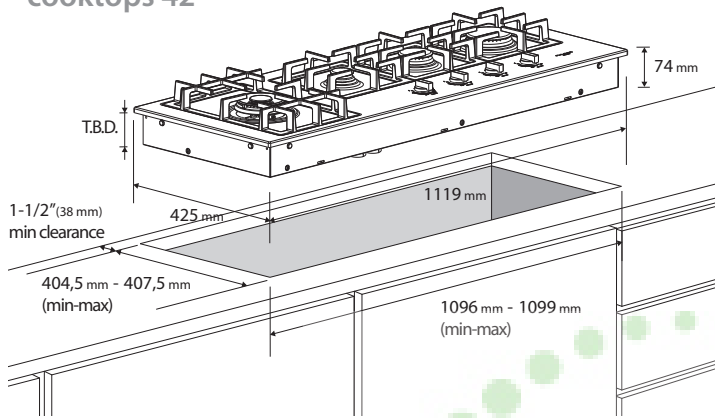

cooktops 30"

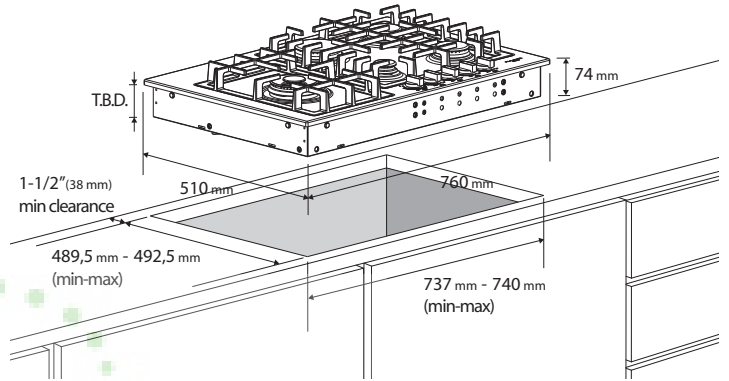

AjMadison
Your Appliance Authority™

cooktops 36"

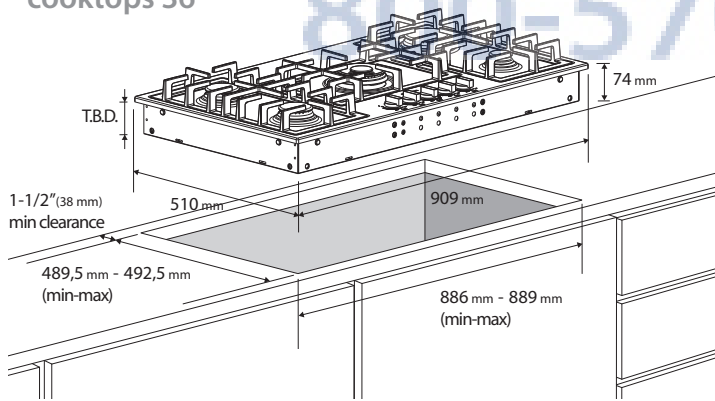

cooktops 24"

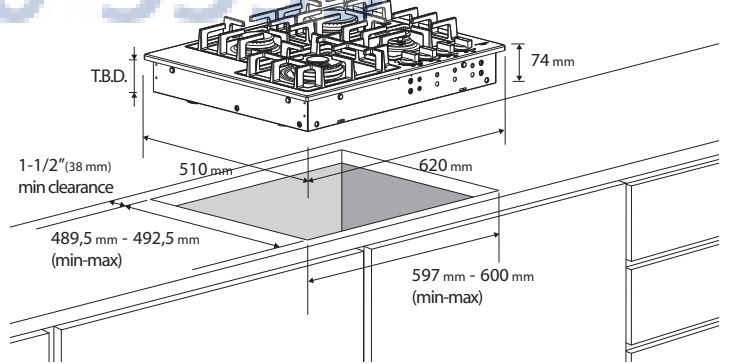

800-570-3355



AjMadison
Your Appliance Authority
800-570-3355



AIMadison
Your Appliance Authority™
800-570-3355

Series 400

Gas Cooktops



AjMadison
Your Appliance Authority™
800-570-3355

F4GK42S1

Gas cooktop 42", 400 Series, with 4 burners, stainless steel

- Electric Flame Ignition and Re-ignition
- Flame out sensing
- Heavy Duty Cast Iron Grates
- On request: simmer Plate and small Pot Insert (for single burners only)
- On request: wok ring (for dual burner only)

Left Burner

- Max. 18000 (BTU/h) - 5275W
- Min. 450 (BTU/h) - 135W

Left Middle Burner

- Max . 4000 (BTU/h) - 1175W
- Min. 1000 (BTU/h) - 295W

Right Middle Burner

- Max . 9000 (BTU/h) - 2640W
- Min. 1300 (BTU/h) - 380W

Right Burner

- Max . 15000 (BTU/h) - 4400W
- Min. 2700 (BTU/h) - 790W

Series 400

Gas Cooktops



AJ Madison
Your Appliance Authority™
800-570-3355

F4GK36S1

Gas cooktop 36", 400 Series, with 5 burners, stainless steel

- Electric Flame Ignition and Re-ignition
- Flame out sensing
- Heavy Duty Cast Iron Grates
- On request: simmer Plate and small Pot Insert (for single burners only)
- On request: wok ring (for dual burner only)

Front Left Burner

- Max. 6300 (BTU/h) - 1850W
- Min. 1300 (BTU/h) - 380W

Rear Left Burner

- Max. 9000 (BTU/h) - 2640W
- Min. 1300 (BTU/h) - 380W

Front Middle Burner

- Max. 18000 (BTU/h) - 5275W
- Min. 450 (BTU/h) - 135W

Rear Right Burner

- Max. 12000 (BTU/h) - 3520W
- Min. 2200 (BTU/h) - 645W

Front Right Burner

- Max. 4000 (BTU/h) - 1175W
- Min. 1000 (BTU/h) - 295W

Series 400

Gas Cooktops



AJ Madison
Your Appliance Authority™

800-570-3355

F4GK30S1

Gas cooktop 30", 400 Series, with 5 burners, stainless steel

- Electric Flame Ignition and Re-ignition
- Flame out sensing
- Heavy Duty Cast Iron Grates
- On request: simmer Plate and small Pot Insert (for single burners only)
- On request: wok ring (for dual burner only)

Front Left Burner

- Max. 18000 (BTU/h) - 5275W
- Min. 450 (BTU/h) - 135W

Front Middle Burner

- Max. 4000 (BTU/h) - 1175W
- Min. 1000 (BTU/h) - 295W

Rear Middle Burner

- Max. 12000 (BTU/h) - 3520W
- Min. 2200 (BTU/h) - 645W

Rear Right Burner

- Max. 9000 (BTU/h) - 2640W
- Min. 1300 (BTU/h) - 380W

Front Right Burner

- Max. 6300 (BTU/h) - 1850W
- Min. 1300 (BTU/h) - 380W

Series 400

Gas Cooktops



AJ Madison
Your Appliance Authority™

800-570-3355

F4GK24S1

Gas cooktop 24", 400 Series, with 4 burners, stainless steel

- Electric Flame Ignition and Re-ignition
- Flame out sensing
- Heavy Duty Cast Iron Grates
- On request: simmer Plate and small Pot Insert (for single burners only)

Front Left Burner

- Max. 18000 (BTU/h) - 5275W
- Min. 450 (BTU/h) - 135W

Rear Left Burner

- Max. 6300 (BTU/h) - 1850W
- Min. 1300 (BTU/h) - 380W

Rear Right Burner

- Max. 12000 (BTU/h) - 3520W
- Min. 2200 (BTU/h) - 645W

Front Right Burner

- Max. 4000 (BTU/h) - 1175W
- Min. 1000 (BTU/h) - 295W



AjMadison
Your Appliance Authority™
800-570-3355

300 Series

Gas Cooktops



Italian wing design for greater surface space and the flexibility to position large pots and pans diagonally on the cooktop.

Patented dual crown burners (36" models only) from 18,000 BTU/H for searing meat and locking in flavor, down to 450 BTU/H.

Sealed burners are easy to clean and to remove.

Heavy-duty cast-iron grates, automatic re-ignition with flame detection, and top mount injectors for better serviceability.

Useful accessories featured, like small-pot reduction, simmer plate and wok ring. Environmentally friendly, made with over 90% recyclable components.



CAST IRON GRATES

Heavy-duty cast-iron grates are designed for you to slide pots and pans from burner to burner



DUAL BURNER

Fulgor-Milano uses a dual-flame European-style sealed burner to deliver a wide range of burner output, from 18,000 BTU/h for meat-searing and wok cooking, down to 450 BTU/h for melting chocolate and locking in flavors



EUROPEAN SEALED BURNERS

Designed with only two removable parts, our sealed burners keep spills from leaking inside the cooktop



SMALL POT REDUCTION

Uniquely designed accessory (included) allows you to use pans smaller than 4 inches on a stable, flat cooking surface, without increasing the distance from the flame



AjMadison
Your Appliance Authority
800-570-3355

DIMENSIONS

cooktops 36"

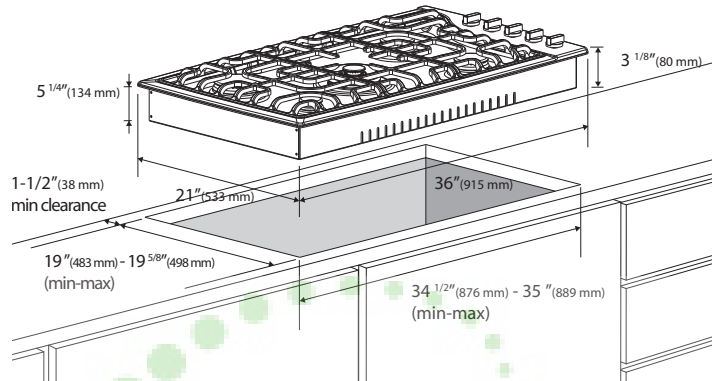

800-570-3355

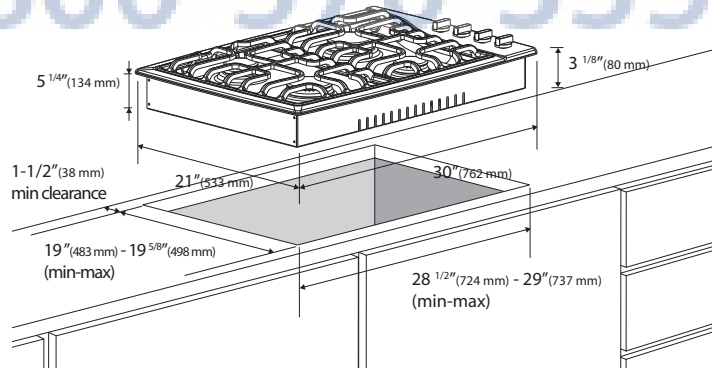



Aj Madison
Your Appliance Authority™
800-570-3355



AjMadison
Your Appliance Authority™
800-570-3355

Series 300

Gas Cooktops

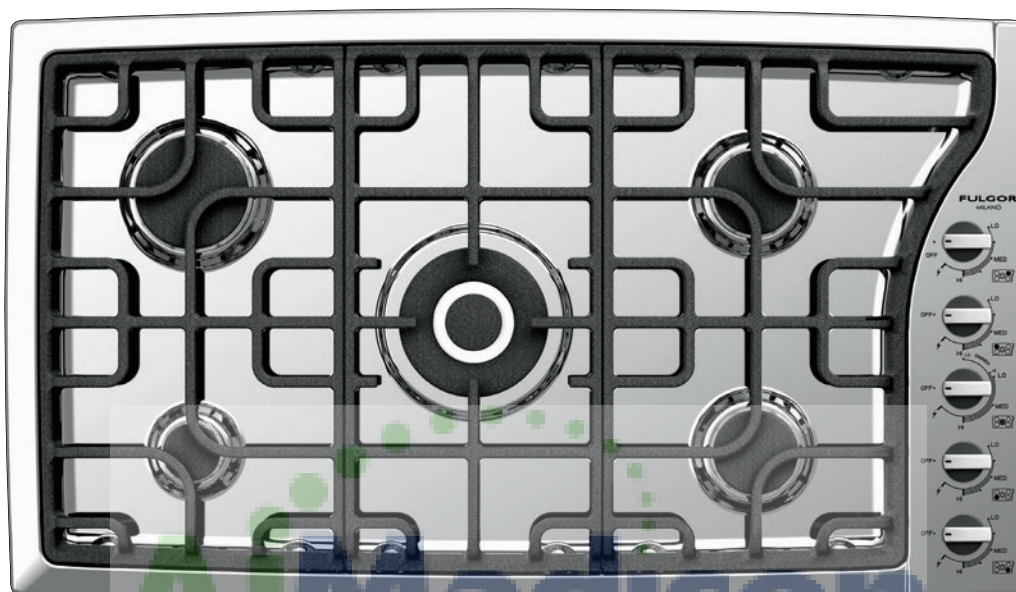

AJ Madison
Your Appliance Authority™
800-570-3355

F3GK36S1

Gas cooktop 36", 300 Series, with 5 burners, stainless steel

- Electric Flame Ignition and Re-ignition
- Flame out sensing
- Dual Crown Burner
- Heavy Duty Cast Iron Grates
- Delivered with small Pot Insert
- On request: wok ring and simmer Plate

Front Left Burner

- Max. 4000 (BTU/h) - 1175W
- Min. 1000 (BTU/h) - 295W

Rear Left Burner

- Max. 15000 (BTU/h) - 4400W
- Min. 1700 (BTU/h) - 500W

Central Burner

- Max. 18000 (BTU/h) - 5275W
- Min. 450 (BTU/h) - 135W

Rear Right Burner

- Max. 9000 (BTU/h) - 2640W
- Min. 1300 (BTU/h) - 380W

Front Right Burner

- Max. 9000 (BTU/h) - 2640W
- Min. 1300 (BTU/h) - 380W

Series 300

Gas Cooktops

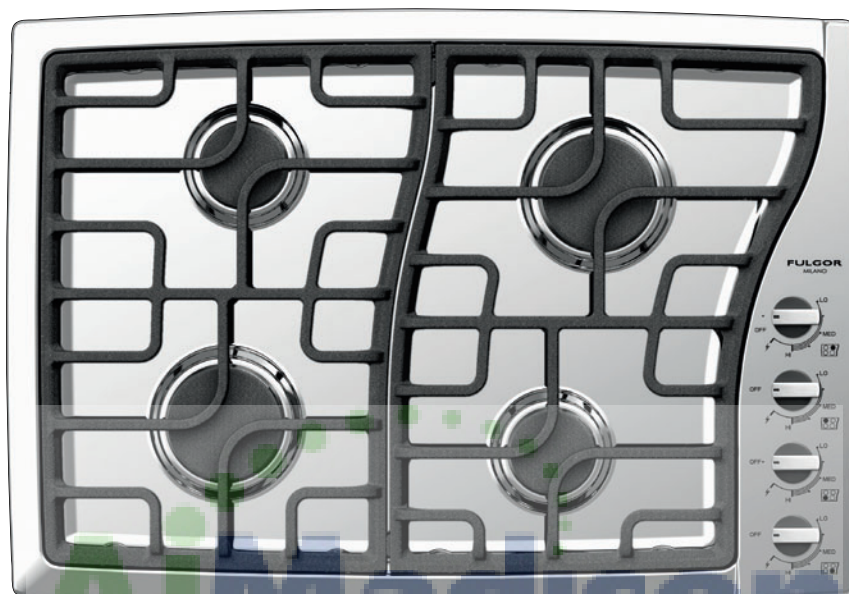

AJ Madison
Your Appliance Authority™

800-570-3355

F3GK30S1

Gas cooktop 30", 300 Series, with 4 burners, stainless steel

- Electric Flame Ignition and Re-ignition
- Flame out sensing
- Heavy Duty Cast Iron Grates
- Delivered with small Pot Insert
- On request: wok ring and simmer Plate

Front Left Burner

- Max. 15000 (BTU/h) - 4400W
- Min. 1700 (BTU/h) - 500W

Rear Left Burner

- Max. 9000 (BTU/h) - 2640W
- Min. 1300 (BTU/h) - 380W

Rear Right Burner

- Max. 12000 (BTU/h) - 3520W
- Min. 1700 (BTU/h) - 500W

Front Right Burner

- Max. 6300 (BTU/h) - 1850W
- Min. 1300 (BTU/h) - 380W

Accessories & Technical Data

Cooktops



Our useful accessories will help you customize your appliances while giving you ease, efficiency and success in your cooking.

Our gas series accessories are guaranteed to enhance your cooking experience, ensuring there is no compromise to your cooking techniques.

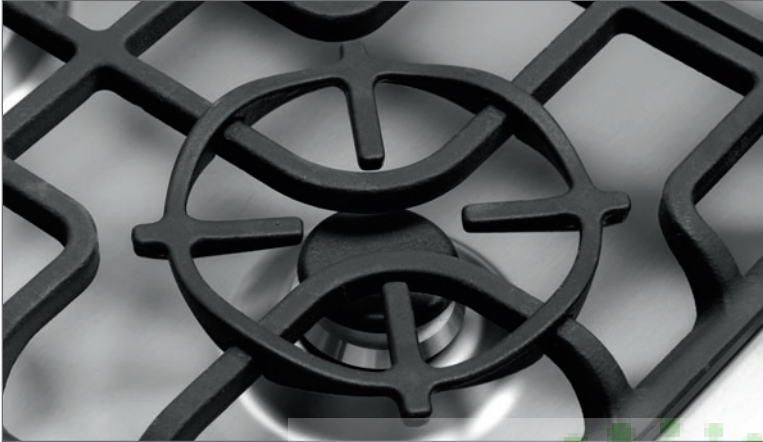

300 & 400 GAS SERIES

SMALL POT REDUCTION

Uniquely designed accessory allows you to use pans smaller than 4 inches on a stable, flat cooking surface



WOK RING

For best results with a wok, use this separate, high-BTU burner specifically for wok cooking



SIMMER PLATE

The cast-iron simmer plate provides a steady simmer temperature, evenly distributed across a stable heating surface



MODEL	F6IT36S1	F6IT30S1
Size	36"	30"
Colour	Steel	Steel
Heating Technology	Induction	Induction
Glass Type	Glass Ceramic	Glass Ceramic
Frame	Aluminum	Aluminum
Control type	Touch Control Peacock High	Touch Control Peacock High
Special Features		
Pan Detection System	X	X
Special Big Double zone	X	
Cooling fan system	X	X
Control Features		
Slide touch control for power setting	X	X
"Peacock Tail" Bar for power indication	X	X
Digital display for power level indication	5	4
Low power scale for delicate cooking	X	X
Command Lock	X	X
Booster/Fast boil function	X	X
Hot Surface indication	X	X
Residual heat indication	X	X
Timer functions	1+5	1+4
Timer display	X	X
Acoustic buzzer	X	X
Failure Codes indication	X	X
Front Left Zone		
Size	6"	6"
Power	1200W	1200W
Booster	1400W	1400W
Rear Left Zone		
Size	8"	8"
Power	2200W	2200W
Booster	3000W	3000W
Central Zone (double)		
Size	11" / 7"	
Power	2650W/1800W	
Booster	3600W/2800W	
Rear Right Zone		
Size	8"	7"
Power	2200W	1800W
Booster	3000W	2800W
Front Right Zone		
Size	6"	6"
Power	1200W	1200W
Booster	1400W	1400W
Dimensions/Weight - (In or Lbs)		
Overall dim - width	36" (919mm)	30" (771mm)
Overall dim - height	3 9/32" (84mm)+ conduit 15/16" (24mm)	3 9/32" (84mm)+ conduit 15/16" (24mm)
Overall dim - depth	21" (538mm)	21" (538mm)
Cutout - width	34 1/16" (865mm) - 34 5/16" (872mm)	28 11/16" (729mm) - 28 15/16" (735mm)
Cutout - height (min)	3 1/16" (78mm)+ conduit 15/16" (24mm)	3 1/16" (78mm)+ conduit 15/16" (24mm)
Cutout - depth (min)	19 19/64" (490mm) - 19 5/8" (498mm)	19 19/64" (490mm) - 19 5/8" (498mm)
Approx ship weight	19.4Kg (43 Lbs)	16.2 Kg (36 Lbs)
Power / Ratings (208/240 V, 60 Hz)		
KW/Amps rating at 240V, 60Hz	10.800kW - 45Amps	7.200kW - 30Amps
KW/Amps rating at 208V, 60Hz	9.700kW - 46,6Amps	6.510kW - 31,3Amps
Cable + Conduit	X	X
Instructions for use		
Use & Care Manual	EN, SP, FR	EN, SP, FR
Installation Manual	EN, SP, FR	EN, SP, FR



MODEL	F6RT36S1	F6RT30S1	F6RT24S1
Size	36"	30"	24"
Colour	Steel	Steel	Steel
Heating technology	Radiant Heaters	Radiant Heaters	Radiant Heaters
Glass Type	Glass Ceramic	Glass Ceramic	Glass Ceramic
Frame	Aluminum	Aluminum	Aluminum
Control type	Touch Control Peacock High	Touch Control Peacock High	Touch Control Peacock Low
Control Features			
Slide touch control for power setting	X	X	NO
"Peacock Tail" Bar for power indication	X	X	NO
Digital display for power level indication	5	4	3
Low power scale for delicate cooking	X	X	X
Command Lock	X	X	X
Automatic Fast Boil function	X	X	X
Hot Surface indication	X	X	X
Residual heat indication	X	X	X
Timer functions	1+5	1+4	1
Timer display	X	X	X
Acoustic buzzer	X	X	X
Failure Codes indication	X	X	X
Front Left Zone			
Size	7"	6"	5"1/2
Power	1800W	1200W	1200W
Bridge Element			
Power	800W		
Rear Left Zone			
Size	7"	9" / 7" / 5"	8" / 5"
Power	1800W	2500W / 1600W / 800W	2200W / 800W
Central Zone			
Size	9" / 7" / 5"		
Power	2500W / 1600W / 800W		
Rear Right Zone			
Size	7"	8" / 5"	7"
Power	1800W	2200W / 800W	1800W
Front Right Zone			
Size	6"	6"	
Power	1200W	1200W	
Dimensions/Weight - (In or Lbs)			
Overall dim - width	36" (919mm)	30" (771mm)	24" (618mm)
Overall dim - height	3 9/32" (84mm)+ conduit 15/16" (24mm)	3 9/32" (84mm)+ conduit 15/16" (24mm)	3 9/32" (84mm)+ conduit 15/16" (24mm)
Overall dim - depth	21" (538mm)	21" (538mm)	21" (538mm)
Cutout - width (min-max)	34 1/16" (865mm) - 34 5/16" (872mm)	28 11/16" (729mm) - 28 15/16" (735mm)	22 5/8" (574mm) - 22 13/16" (580mm)
Box - height	3 1/16" (78mm)+ conduit 15/16" (24mm)	3 1/16" (78mm)+ conduit 15/16" (24mm)	3 1/16" (78mm)+ conduit 15/16" (24mm)
Cutout - depth (min-max)	19 19/64" (490mm) - 19 5/8" (498mm)	19 19/64" (490mm) - 19 5/8" (498mm)	19 1/4" (490mm) - 19 9/16" (497mm)
Power / Ratings (208/240 V, 60 Hz)			
KW/Amps rating at 240V, 60Hz	9.90kW - 41.25Amps	7.100kW - 29.58Amps	5.200kW - 21.67Amps
KW/Amps rating at 208V, 60Hz	7.436kW - 35.75Amps	5.332kW - 25.63Amps	3.900kW - 18.75Amps
Cable + Conduit	X	X	X
Instructions for use			
Use & Care Manual	EN, SP, FR	EN, SP, FR	EN, SP, FR
Installation Manual	EN, SP, FR	EN, SP, FR	EN, SP, FR

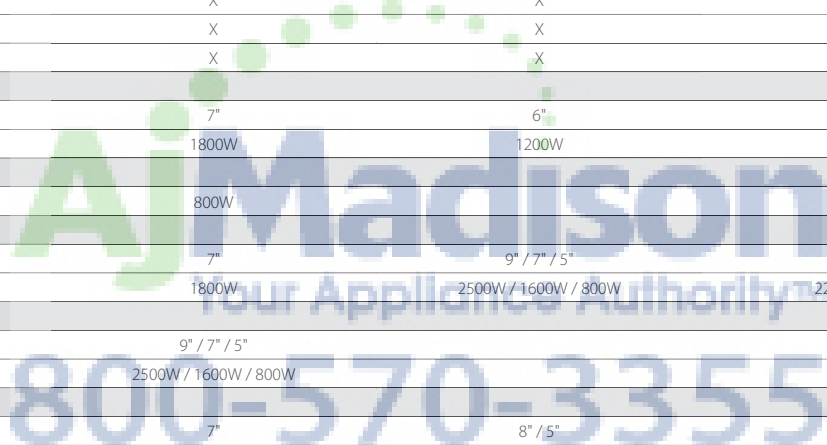



MODEL	F3RK36B1	F3RK30B1	F3RK24B1	F3RK24S1
Size	36"	30"	24"	24"
Colour	Black	Black	Black	Stainless Steel
Heating Technology	Radiant Heaters	Radiant Heaters	Radiant Heaters	Radiant Heaters
Glass Type	Glass Ceramic	Glass Ceramic	Glass Ceramic	Glass Ceramic
Frame	NO	NO	NO	Aluminium
Control type	Knobs	Knobs	Knobs	Knobs
Control Features				
Knobs for power level setting	5	4	4	4
Knobs type	Plastic MGH "U"	Plastic MGH "U"	Plastic MGH "U"	Plastic MGH "U"
Hot Surface indication	X	X	X	X
Residual heat indication	X	X	X	X
Front Left Zone				
Size	9" / 6"	9" / 6"	7"	7 3/4" / 4 3/4"
Power	2500W / 1100W	2500W / 1100W	1800W	1900W / 800W
Rear Left Zone				
Size	6"	6"	5 1/2"	5 1/2"
Power	1200W	1200W	1200W	1200W
Central Zone				
Size	11" / 8"			
Power	2700W / 1800W			
Rear Right Zone				
Size	7"	7"	7"	7"
Power	1800W	1800W	1800W	1800W
Front Right Zone				
Size	6"	6"	5 1/2"	5 1/2"
Power	1200W	1200W	1200W	1200W
Dimensions/Weight - (In or Lbs)				
Overall dim - width	36" (914mm)	30 1/4" (767mm)	24" (613mm)	24" (618mm)
Overall dim - height	2 3/16" (56mm)	2 3/16" (56mm)	3 9/32" (84mm)+ conduit 15/16" (24mm)	3 9/32" (84mm)+ conduit 15/16" (24mm)
Overall dim - depth	21" (533mm)	21" (533mm)	21" (533mm)	21" (538mm)
Cutout - width (min-max)	34 1/16" (865mm) - 34 5/16" (872mm)	28 11/16" (729mm) - 28 15/16" (735mm)	22 5/8" (574mm) - 22 13/16" (580mm)	22 5/8" (574mm) - 22 13/16" (580mm)
Box - height	2" (50,8mm) + conduit 15/16" (24mm)	2" (50,8mm) + conduit 15/16" (24mm)	3 1/16" (78mm)+ conduit 15/16" (24mm)	3 1/16" (78mm)+ conduit 15/16" (24mm)
Cutout - depth (min-max)	19 1/4" (490mm) - 19 9/16" (497mm)	19 1/4" (490mm) - 19 9/16" (497mm)	19 1/4" (490mm) - 19 9/16" (497mm)	19 1/4" (490mm) - 19 9/16" (497mm)
Approx ship weight	17.5 Kg (38.6Lbs)	13.5 Kg (30Lbs)	13.5 Kg (30Lbs)	13.5 Kg (30Lbs)
Power / Ratings (208/240 V, 60 Hz)				
KW/Amps rating at 240V, 60Hz	9.400kW - 39.17Amps	6.700kW - 27.9Amps	6.000kW - 25.00Amps	6.100kW - 25.42Amps
KW/Amps rating at 208V, 60Hz	7.060kW - 33.94Amps	5.032kW - 24.19Amps	4.507kW - 21.67Amps	4.582kW - 22.03Amps
Cable + Conduit	X	X	X	X
Instructions for use				
Use & Care Manual	EN, SP, FR	EN, SP, FR	EN, SP, FR	EN, SP, FR
Installation Manual	EN, SP, FR	EN, SP, FR	EN, SP, FR	EN, SP, FR



MODEL	F4GK42S1	F4GK36S1	F4GK30S1	F4GK24S1
Size	42"	36"	30"	24"
Colour	Stainless Steel	Stainless Steel	Stainless Steel	Stainless Steel
Heating Technology	Gas	Gas	Gas	Gas
Gas Type	NG or LP	NG or LP	NG or LP	NG or LP
L.P. Conversion Kit	X	X	X	X
Top Mount Injectors	X	X	X	X
Knobs	Plastic MGH "U" - Frontal	Plastic MGH "U" - Frontal	Plastic MGH "U" - Frontal	Plastic MGH "U" - Frontal
Cooktop Features				
Design	Largo	Largo	Largo	Largo
Electric Flame Ignition and Re-ignition	X	X	X	X
Flame out sensing	X	X	X	X
Dual Crown Burner	X	X	X	X
Simmer Plate	Optional	Optional	Optional	Optional
Small Pot Insert	Optional (for single burners only)	Optional (for single burners only)	Optional (for single burners only)	Optional (for single burners only)
Wok Ring	Optional (for dual burner only)	Optional (for dual burner only)	Optional (for dual burner only)	Not available
Heavy Duty Cast Iron Grates	4	3	2	4
Number of Burners	4	5	5	4
Burner 1	Left Burner	Front Left Burner	Front Left Burner	Front Left Burner
Power (Max)	18000 (BTU/h) - 5275W	6300 (BTU/h) - 1850W	18000 (BTU/h) - 5275W	18000 (BTU/h) - 5275W
Power (Min)	450 (BTU/h) - 135W	1300 (BTU/h) - 380W	450 (BTU/h) - 135W	450 (BTU/h) - 135W
Burner 2		Rear Left Burner	Rear Left Burner	Rear Left Burner
Power (Max)		9000 (BTU/h) - 2640W		6300 (BTU/h) - 1850W
Power (Min)		1300 (BTU/h) - 380W		1300 (BTU/h) - 380W
Burner 3	Left Middle Burner	Front Middle Burner	Front Middle Burner	Front Middle Burner
Power (Max)	4000 (BTU/h) - 1175W	18000 (BTU/h) - 5275W	4000 (BTU/h) - 1175W	
Power (Min)	1000 (BTU/h) - 295W	450 (BTU/h) - 135W	1000 (BTU/h) - 295W	
Burner 4	Right Middle Burner	Rear Middle Burner	Rear Middle Burner	Rear Middle Burner
Power (Max)	9000 (BTU/h) - 2640W		12000 (BTU/h) - 3520W	
Power (Min)	1300 (BTU/h) - 380W		2200 (BTU/h) - 645W	
Burner 5		Rear Right Burner	Rear Right Burner	Rear Right Burner
Power (Max)		12000 (BTU/h) - 3520W	9000 (BTU/h) - 2640W	12000 (BTU/h) - 3520W
Power (Min)		2200 (BTU/h) - 645W	1300 (BTU/h) - 380W	2200 (BTU/h) - 645W
Burner 6	Right Burner	Front Right Burner	Front Right Burner	Front Right Burner
Power (Max)	15000 (BTU/h) - 4400W	4000 (BTU/h) - 1175W	6300 (BTU/h) - 1850W	4000 (BTU/h) - 1175W
Power (Min)	2700 (BTU/h) - 790W	1000 (BTU/h) - 295W	1300 (BTU/h) - 380W	1000 (BTU/h) - 295W
Dimensions/Weight - (In or Lbs)				
Overall dim - width	1119mm	909mm	760mm	620mm
Overall dim - height	74mm	74mm	74mm	74mm
Overall dim - depth	425mm	510mm	510mm	510mm
Cutout - width (min-max)	1096mm-1099mm	886mm - 889mm	737mm - 740mm	597mm-600mm
Cutout - height	T.B.D.	T.B.D.	T.B.D.	T.B.D.
Cutout - depth (min-max)	404,5mm - 407,5mm	489,5mm - 492,5mm	489,5mm - 492,5mm	489,5mm - 492,5mm
Power / Ratings				
Electrical rating	120V, 60Hz	120V, 60Hz	120V, 60Hz	120V, 60Hz
Max Power (BTU/HR)	46000 (BTU/h) - 13475W	52300 (BTU/h) - 15320W	49300 (BTU/h) - 14440W	40300 (BTU/h) - 11800W
Cable	X	X	X	X
Instructions for use				
Use & Care Manual	EN, SP, FR	EN, SP, FR	EN, SP, FR	EN, SP, FR
Installation Manual	EN, SP, FR	EN, SP, FR	EN, SP, FR	EN, SP, FR

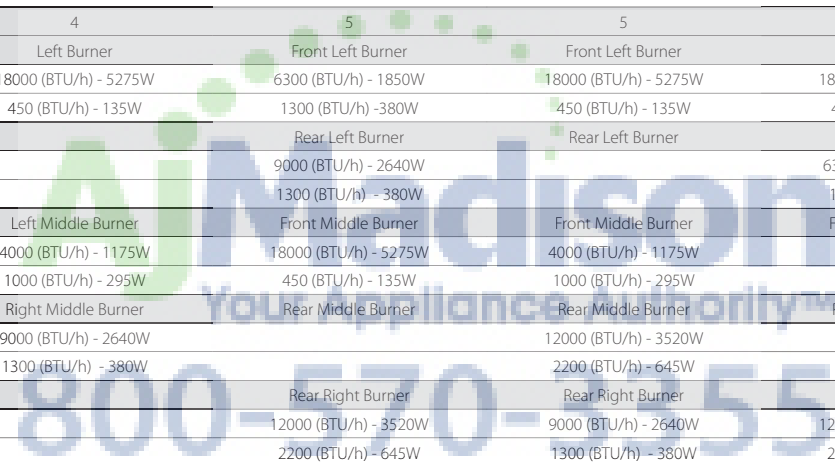



MODEL	F3GK36S1	F3GK30S1
Size	36"	30"
Colour	Stainless Steel	Stainless Steel
Heating Technology	Gas	Gas
Gas Type	NG or LP	NG or LP
L.P. Conversion Kit	X	X
Top Mount Injectors	X	X
Knobs	Plastic MGH "U" - Lateral	Plastic MGH "U" - Lateral
Cooktop Features		
Design	Lateral Wing	Lateral Wing
Electric Flame Ignition and Re-ignition	X	X
Flame out sensing	X	X
Dual Crown Burner	X	
Simmer Plate	Optional	Optional
Small Pot Insert	X	X
Wok Ring	Optional	Optional
Heavy Duty Cast Iron Grates	3	2
Number of Burners	5	4
Burner 1	Front Left Burner	Front Left Burner
Power (Max)	4000 (BTU/h) - 1175W	15000 (BTU/h) - 4400W
Power (Min)	1000 (BTU/h) - 295W	1700 (BTU/h) - 500W
Burner 2	Rear Left Burner	Rear Left Burner
Power (Max)	15000 (BTU/h) - 4400W	9000 (BTU/h) - 2640W
Power (Min)	1700 (BTU/h) - 500W	1300 (BTU/h) - 380W
Burner 3	Central Burner	Central Burner
Power (Max)	18000 (BTU/h) - 5275W	
Power (Min)	450 (BTU/h) - 135W	
Burner 4	Rear Right Burner	Rear Right Burner
Power (Max)	9000 (BTU/h) - 2640W	12000 (BTU/h) - 3520W
Power (Min)	1300 (BTU/h) - 380W	1700 (BTU/h) - 500W
Burner 5	Front Right Burner	Front Right Burner
Power (Max)	9000 (BTU/h) - 2640W	6300 (BTU/h) - 1850W
Power (Min)	1300 (BTU/h) - 380W	1300 (BTU/h) - 380W
Burner 6		
Power (Max)		
Power (Min)		
Dimensions/Weight - (In or Lbs)		
Overall dim - width	36" (915mm)	30" (762mm)
Overall dim - height	3 1/8" (80mm)	3 1/8" (80mm)
Overall dim - depth	21" (533mm)	21" (533mm)
Cutout - width (min-max)	34 1/2" (876mm) - 35" (889mm)	28 1/2" (724mm) - 29" (737mm)
Cutout - height	5 1/4" (134mm)	5 1/4" (134mm)
Cutout - depth (min-max)	19" (483mm) - 19 5/8" (498mm)	19" (483mm) - 19 5/8" (498mm)
Power / Ratings		
Electrical rating	120V, 60Hz	120V, 60Hz
Max Power (BTU/HR)	55000 (BTU/h) - 16110W	42300 (BTU/h) - 12390W
Cable	X	X
Instructions for use		
Use & Care Manual	EN, SP, FR	EN, SP, FR
Installation Manual	EN, SP, FR	EN, SP, FR









FULGOR
MILANO

Registered Trade Mark of Meneghetti

Meneghetti S.p.a.
Via Borgo Lunardon, 8
36027 Rosà (Vicenza) - Italy

<http://www.fulgor-milano.us>
e-mail: info@fulgor-milano.us