

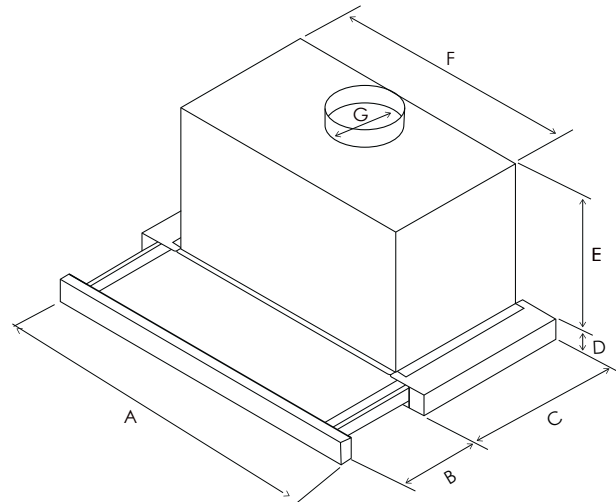

LED LIGHT

ELICA'S EXCLUSIVE PLUS FEATURES

The ultra slim design of TT hides quietly within cabinetry and extends less than 2" below the edge. When called to action, the horizontal visor effortlessly pulls out to provide added air capture during cooking. TT design is ideal for smaller kitchens or where under-cabinet space is limited. The 400 CFM blower provides more than adequate power for everyday cooking. The 3 speed blower and LED lighting are operated with modern electronic touch controls, which are out of sight and behind the visor when idle.



	ETT424S1	ETT430SS	ETT436SS
A	23 ½ "	30"	35 ½ "
B	6"		
C	11"		
D	1 ¼ "		
E	10 ¾ "		
F	18 ½ "	24 ½ "	30"
G	6"		

Width:	24" Unit	30" Unit	36" Unit
Model:	ETT424S1	ETT430SS	ETT436SS
Dimensions:	24" W x Min: 11" Max: 17"D x 11 3/4" H	30" W x Min: 11" Max: 17"D x 11 3/4" H	36" W x Min: 11" Max: 17" Dx 11 3/4" H
Blower Type(internal):**	400 CFM (3 - speed)		
Noise (sones):**	5.9 Sones		
Finish:	Stainless Steel		
Controls:	Hidden Electronic Touch Controls		
Illumination:	2 LED Lights, 2.1 Watts 3000 K		
Grease Filter:	Dishwasher-Safe, Anodized Aluminum Mesh Filter		
Duct Transition:	Round 6" Top Discharge		
Installation Type:	Ducted or Recirculating (Kit sold separately)		
Electrical:	120V - 60 Hz, 245 W		
KITS:			
Charcol Filter Kit:	CFC0038668		
Recirculation Deflector:	DF01EA (contains 6" round plastic deflector, for optional use with CFC0038668)		
CFM Reduction Kit:	KIT02748 (contains plate, achieves 300 cfm or less)		
WARRANTY:***	Two (2) Years Parts & In-Home Labor. Earn an additional One (1) Year of Parts & In-Home Labor by registering on elica.com.		

PLUS FEATURES



LED LIGHT - LED lighting is undoubtedly the smartest solution in terms of energy saving. Expected life is over 20,000 hours, and should last the full life of the hood.

HVI Certified Ratings	High Speed	Working Speed	Duct Size
CFM	280	100	6" (Vertical)
Sones	5	0.4	6" (Vertical)

* The product images shown are for illustration purposes only and may not be an exact representation of the product.

** Blower performance indicates the performance of the blower by itself. Performance claims are not HVI certified but were established in accordance with HVI Standardized test procedure. For Certified Ratings, please refer to HVI Certified Product Directory. Electric Ratings are declared according to UL.

*** For valid warranty extension, register within 3 months from purchase. For USA & Canada Users Only.