



---

E0241250

ELECTRIC OVEN  
FOUR ÉLECTRIQUE  
HORNO ELÉCTRICO



---

**DeLonghi**

**EN**

page 10

**FR**

page 28

**ES**

pág. 53

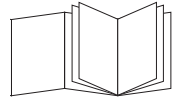

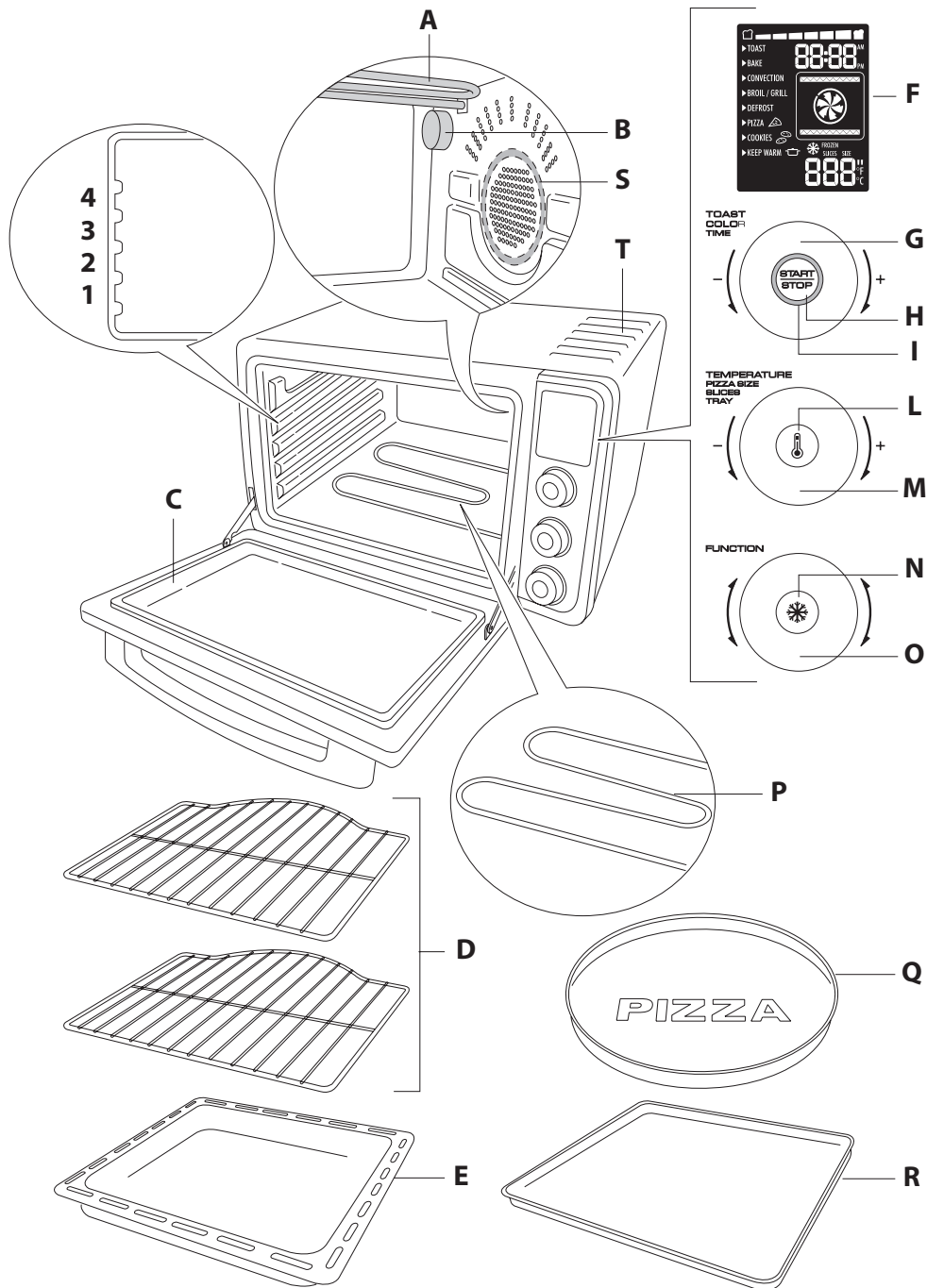

## CONTENTS

ELECTRICAL CONNECTION .....	4
IMPORTANT SAFEGUARDS .....	5
TECHNICAL SPECIFICATION .....	6
DESCRIPTION OF THE APPLIANCE .....	6
INSTALLATION .....	6
ERROR MESSAGE .....	6
SETTING THE CLOCK.....	7
OVEN FUNCTION.....	7
FUNCTION SUMMARY TABLE.....	8
TOAST .....	10
BAKE.....	11
CONVECTION .....	12
BROIL/GRILL.....	13
DEFROST.....	14
PIZZA.....	15
COOKIES.....	17
KEEP WARM.....	18
SLOW COOKER .....	19
CARE AND CLEANING .....	19
DISPOSAL .....	20
RECIPES LIST.....	21
TROUBLESHOOTING .....	23
RECIPES .....	25

## ELECTRICAL CONNECTION

Only use a three-pin, 120 Volt, 60 Hz power outlet

### GROUNDING INSTRUCTIONS

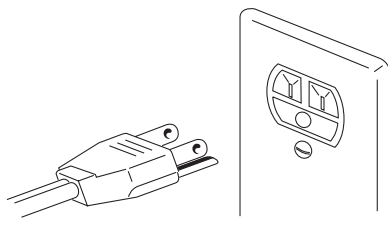

### CAUTION: MAKE SURE THAT THE PLUG IS CORRECTLY GROUNDED

This appliance must be grounded: in the event of short circuits, the ground connection reduces the risk of electric shock, allowing the electrical current to be dispersed. This appliance is fitted with a power cable with ground wire.

The plug must be connected to a power outlet that has been correctly installed and grounded.

### WARNING: IMPROPER USE OF THE GROUND WIRE MAY LEAD TO THE RISK OF ELECTRIC SHOCK.

If you are not sure that the power outlet is properly grounded, contact a qualified electrician.

The length of the power cable for this appliance has been devised so as to avoid the possibility of tripping on or getting entangled in a long cable.

If an extension cord is required, only use three-wire extension cords with three-pin plugs and sockets that fit the plug on the appliance.

The electrical ratings of the extension cord must be at least as great as the electrical ratings of the appliance. If a longer cable is required, an extension cord UL/CSA approved can be used.



When using an extension cord, make sure it does not hang loose in the work area or where someone may accidentally trip on it or get entangled in it.

Handle the power cable with care for longer life; avoid pulling or stressing the cable around the connectors to the power outlet and the appliance.

# IMPORTANT SAFEGUARDS

When using electrical appliances, a number of fundamental safety rules must be observed, including the following:

## 1. READ ALL INSTRUCTIONS THIS PRODUCT IS DESIGNED FOR HOUSEHOLD USE ONLY. DO NOT USE OUTDOORS.

2. Do not use this appliance for purposes other than those it has been designed for.
3. Do not touch the hot surfaces. Only use the knobs or handles to operate the appliance .
4. Remove any objects located above the appliance. Do not use on surfaces that may be damaged by the heat. If the oven is used on countertop made in solid surface material (e.g. Silestone®, Corian®, etc.), follow carefully the indications of countertop manufacturer and/or supplier.
5. To avoid electric shock, do not immerse the appliance in water. See the instructions for cleaning.
6. If the appliance is used when children are around, pay careful attention to the metal walls of the oven and the door, which become very hot . The appliance must not be used by children or persons with reduced physical, sensory or mental capabilities or lack of experience and knowledge without supervision. Make sure that children do not play with the appliance.
7. Unplug the appliance from the power outlet when this is not being used or before cleaning. Wait for the appliance to cool down at least 30 minutes before fitting or removing any parts.
8. Never operate the appliance with the cable or the plug damaged, if any malfunctions have occurred, or if the appliance has been damaged in any way. Take the appliance to the nearest authorized service center, which will inspect it and, if necessary, will adjust or repair it.
9. After-sales accessories may be used if their shape, size and material are suitable for the use on this oven. The use of accessories that are not recommended by the manufacturer may cause injuries.
10. Do not let the power cable hang from the counter or come into contact with hot surfaces.

11. Do not place the appliance above or near a gas or electric cooker.
12. Use maximum care when moving the appliance or accessories if they contains hot oil or other hot liquids. Always use oven gloves.
13. If the plug heats up, contact a qualified electrician.
14. Use maximum care when removing the bake pan or throwing out the hot fat.
15. Do not use abrasive/aggressive/acid detergent, metal sponges or steel wool to clean the appliance.
16. To ensure the safe operation of the appliance, never introduce foods that are too large for the oven.
17. If the appliance, when operating, is covered by or comes into contact with flammable materials, such as curtains, fabrics or wall coverings etc. there will be risk of fire! Use extreme care to avoid these conditions.
18. WARNING: Never leave the appliance unattended when operating (especially when broiling or toasting).
19. When broiling, the bake pan and the wire racks must be used as described in the instructions.
20. Extreme care must be taken when using containers made from materials other than glass, metal or ovenproof ceramics.
21. Do not place any objects in the oven when it is not being used, apart from the accessories recommended by the manufacturer.
22. Do not place any of the following materials into or on top of the oven: paper, cardboard, plastic and the like.
23. Do not cover parts of the oven with metal foil, to avoid overheating. Do not place any materials over the vent openings (T), located on top housing.
24. To switch the appliance off, press START/STOP button.
25. To disconnect the appliance, turn off any control, than remove the plug from wall outlet.
26. Oversize food or metal utensiles must not be inserted inside the oven as they may create risk of fire or risk of electric shock.
27. The appliance does not exceed 60 minutes "on" in a two hours period.
28. This product is in compliance with UL and CSA safety standards.

# SAVE THESE INSTRUCTIONS

**WARNING:** After having removed the appliance from its packaging, check that the door is intact.

The door is made from glass and is therefore fragile. If it is visibly chipped, scored or scratched, it should be replaced. While using, cleaning or moving the appliance, avoid slamming or knocking the door. Do not pour cold liquid onto the glass while the appliance is hot.

**WARNING:** The accessories for cooking of this appliance are not suitable for food preservation. Avoid leaving for prolonged time acid substances as lemon/oragne juice, tomato or vinegar on accessorie's surface. If left on surfaces for prolonged time these substances may damage and impire the non stick coating.

**WARNING:** Caution should be exercised when using baking paper or metal foil to cover accessories, pans an pishes. Close contact with heating elements of baking paper and metal foil may cause overheating and risk of fire.



## TECHNICAL SPECIFICATION

Voltage: 120 V ~ 60Hz

Absorbed power: 1800 W

Overall dimensions: LxPxH 193x173x118 in (490x445x300 cm)

## DESCRIPTION OF THE APPLIANCE

- A Top heating element
- B Internal light
- C Glass door
- D Wire racks
- E Bake pan
- F Display
- G TOAST COLOR/TIME dial
- H START/STOP button
- I Red on light
- L  Cavity temperature check button (°C/°F setting)
- M TEMPERATURE/PIZZA SIZE/SLICES/TRAY dial
- N  Frozen option button
- O FUNCTION selection dial
- P Lower heating element
- Q Pizza pan
- R Crumb tray
- S Fan heating element (not visible)
- T Vent openings

## DISPLAY

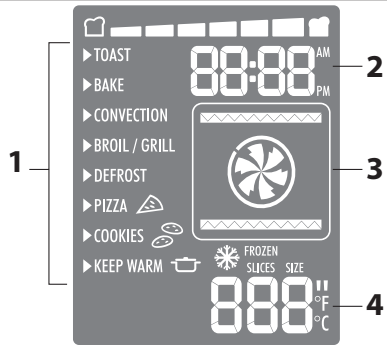

- 1 Function selected indicator
- 2 Timer/clock indicator
- 3 Function icon
- 4 Temperature/size/slices indicator

## INSTALLATION

- Check that the appliance has not suffered any damage due to transportation.
- Place the appliance on a flat, stable surface out of the reach of children (the glass door becomes hot while the oven is in operation).
- Before using this appliance, move it away from the wall or any object on the counter top. Remove any object that may have been placed on top of the appliance. Do not use on surfaces where heat may be a problem.

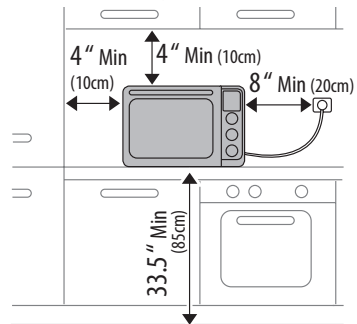

- In order to remove any protective substances on the heating elements surfaces, it is necessary to run the oven empty for 30 minutes in CONVECTION function at 450 °F, as first use. This operation may result in minimal smell and smoke. This is normal. Let the appliance cool down for 30 minutes after this operation.
- The crumb tray (R) must be always placed on oven bottom, under lower heating element (P).

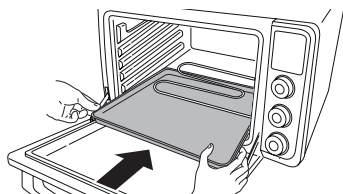

## ERROR MESSAGES

If *ERR* message is shown on display, with relevant acoustic signal, the oven had a malfunction. Press START/STOP button (H) for 2 seconds to reset the control and disconnect the plug from wall outlet. Check troubleshooting section.

## SETTING THE CLOCK

The first time the appliance is connected to the main electricity supply or after it has been without power for some time, it play a beep and four dashes (“--:--”) appear on the display.

After 5 seconds the display will turn off, due to the clock has not been set, and the electronic control go on stand-by state.

To set the time, proceed as follows:

Press the START/STOP button (H) for at least 5 seconds.



The hour flashes.



Set the required hour with TOAST COLOR/TIME dial (G).

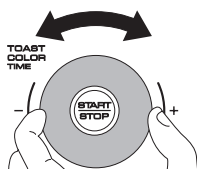

Press the START/STOP button (H). The minutes flash.



Set the required minutes with TOAST COLOR/TIME dial (G).



Press the START/STOP button (H). The set time is displayed.



If you want to adjust the time later, repeat the setting procedure described above. The electronic control must be in stand-by state to adjust the clock.

## OVEN FUNCTION

In the stand-by state, the Display shows the clock (if set) or --:--.

- Press any button (H L N) or turn any dial (G M O). The oven turns on. This is the Function selecting state. The Default selected function is BAKE. The modifiable values flash.

If during function selection state no button are pressed or dial are turned within 2 minutes, the control comes back in stand-by mode.

- Turn the FUNCTION selection dial (O) to select the function wanted.
- Turn the TEMPERATURE/PIZZA SIZE/SLICES/TRAY dial (M) to set the temperature if needed (not required in some programs). In some function the temperature is automatically set (the display doesn't show the preset temperature).

In the PIZZA function set the size.

In the COOKIES function set the number of trays.









- Turn the TOAST COLOR/TIME dial (G) to set the timer if needed.
- Both PIZZA and COOKIES functions have a preset timer.
- In PIZZA function the time will change depending on the selected size.
- In COOKIES function it is possible to modify the cooking time.
- Press the START/STOP button (H) to start cooking. The red ON light (I), that is located around the edge of the START/STOP button (H), turns on. When the timer elapsed, the display shows “End” and play a sound signal.

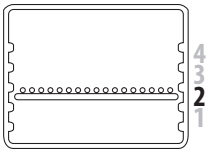

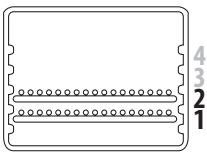

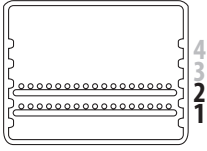

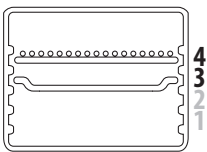
Press START/STOP button (H) to reset the oven and stop the function. It is possible to interrupt the cooking process at any time by pressing START/STOP button (H). The oven goes into stand-by condition. In the BAKE, CONVECTION and COOKIES functions, the oven play a sound signal when the first target temperature is reached. In BAKE and CONVECTION function is possible to check the cavity temperature by pressing the  Cavity temperature check button (L). The temperature is displayed for 5 seconds.

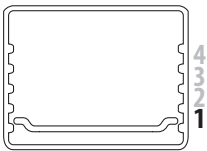
- Is possible to choose the temperature visualization in °F or in °C. Default setting is in °F. To change setting select BAKE or CONVECTION function, press  Cavity temperature check button (L) for 5 seconds. The visualization will change to °C with acoustic signal. To come back to °F visualization repeat the same operation.

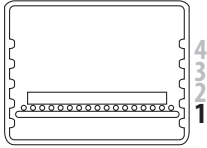
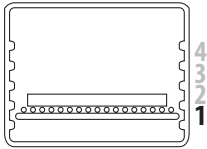

## FUNCTIONS SUMMARY TABLE

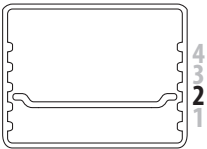
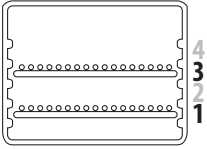
FUNCTION	TEMPERATURE	TIMER	WIRE RACK AND BAKE PAN POSITION	RECIPES
 TOAST	(Auto selected)	(Auto selected)	 <p>wire rack in position 2</p>	Specific for toasting slices of bread.
 BAKE	170°F - 450°F 75°C - 230°C	0:01 (minutes) - 2:00 (hours)	 <p>wire rack or bake pan in position 1 or 2</p>	Ideal for: cakes bread fish lasagna (see page 21-22)
 CONVECTION	170°F - 450°F 75°C - 230°C	0:01 (minutes) - 2:00 (hours)	 <p>wire rack or bake pan in position 1 or 2</p>	Ideal for: quiches poultry potatoes pastry cakes (see page 21-22)
 BROIL/GRILL	(Auto selected)	0:01 (minutes) - 2:00 (hours)	 <p>wire rack in position 4, bake pan in position 3</p>	Ideal for: pork chops sausages pork ribs wurstel (see page 21-22)
 DEFROST	-	0:01 (minutes) - 2:00 (hours)	 <p>wire rack or bake pan in position 1</p>	Ideal to help the food to be defrosted in shorter time

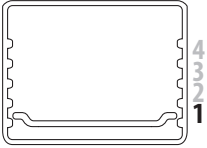
FUNCTION		TEMPERATURE	TIMER	WIRE RACK AND BAKE PAN POSITION	RECIPES
 PIZZA	Frozen 	(Auto selected)	(Auto selected and adjustable)	 pizza pan on wire rack in position 1	Automatic program for crispy frozen pizza.
	Fresh	(Auto selected)	(Auto selected and adjustable)	 pizza pan on wire rack in position 1	Automatic program for perfect fresh pizza.
 COOKIES	1tr	(Auto selected)	(Auto selected and adjustable)	 bake pan in position 2	Automatic program for perfect cookies.
	2tr	(Auto selected)	(Auto selected and adjustable)	 rack in position 1 and 3	Automatic program for biscuits for all family.
 KEEP WARM		(Auto selected)	0:01 (minutes) - 6:00 (hours)	 wire rack or bake pan in position 1 or 2	Ideal to keep warm the food just cooked. This function can be also used as slow cooker.

### TIPS FOR HEALTY COOKING

When you are cooking high fat content food, in BAKE and CONVECTION functions, we suggest to place the food directly on the wire rack inserted in position 2 and the bake pan in position 1. In this way the excessive fat will drain on the bake pan.

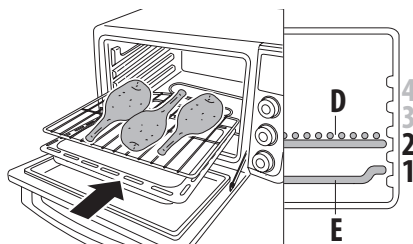

## TOAST

Place the slices to toast (2, 4 or 6) on the wire rack (D) and insert in the oven in position 2.

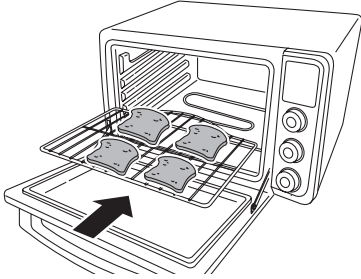

For a better toasting result place the slices as shown.



The edges of the slices should be aligned and close to the central wire.

Close the door.

Press any button (H L N) or turn any dial (G M O)

The oven turns on.

The default selected function is TOAST.

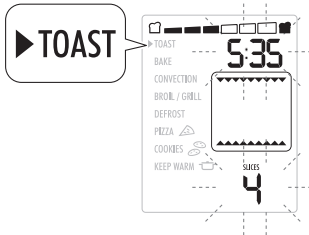

Set the desired level of toasting by turning the TOAST COLOR/TIME dial (G).

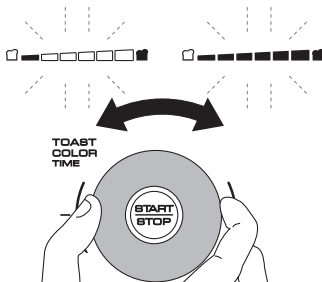

Turn the TEMPERATURE/PIZZA SIZE/SLICES/TRAY dial (M) to select the desired number of slices to toast.

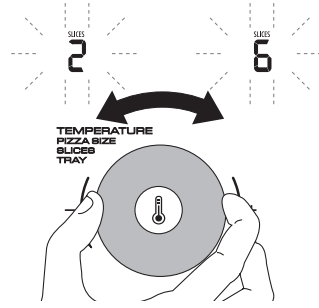

Press the START/STOP button (H) to start cooking.

The red ON light (I), that is located around the edge of the START/STOP button (H), turns on.

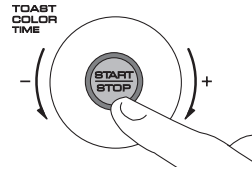

The oven starts the cooking process.

At the end of the set time the appliance will play a sound signal and the display will show *END*.



To turn the appliance off during running function or reset the control at end of time when *END* is showed on display, press the START/STOP button (H) for 2 seconds.

Open the door and remove the food. Take great care when taking the food out of the oven. Use oven gloves.

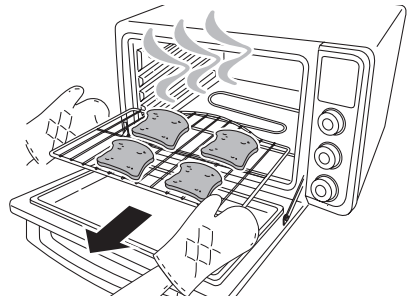

## BAKE

Press any button (H L N) or turn any dial (G M O).  
The oven turns on. The default selected function is TOAST.

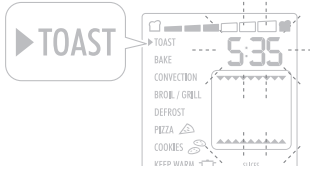

Turn the FUNCTION selection dial (O) to set the BAKE mode.

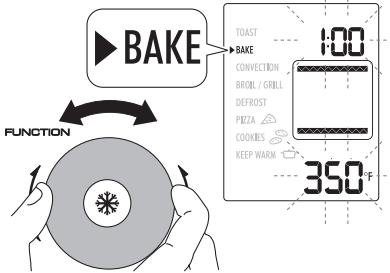

Turn the TEMPERATURE/PIZZA SIZE/SLICES/TRAY dial (M) to set the desired temperature. The default temperature is 350 °F.

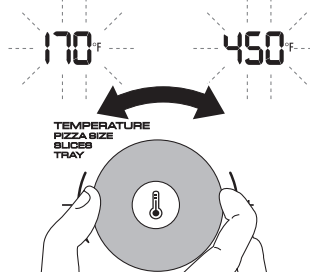

Turn the TOAST COLOR/TIME dial (G) to set the desired timer.  
The default time is 1:00 (hour).

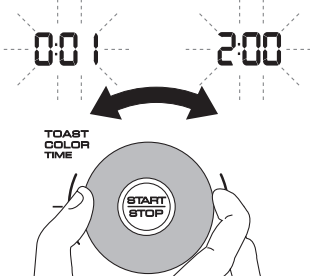

Press the START/STOP button (H) to start cooking.  
The red ON light (I), that is located around the edge of the START/STOP button (H), turns on.

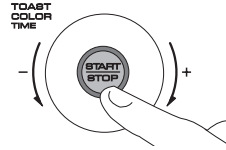

The oven starts the preheating phase. *PRE HEAT* message is shown on display. When the oven reaches the set temperature, an audible signal will sound. The countdown will start. Place the food on the wire rack (D) or bake pan (E) and insert in the oven in position 1 or 2.

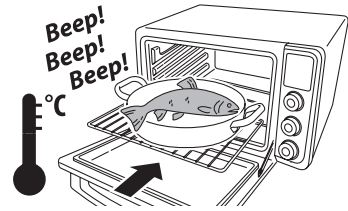

Close the door.

At the end of the set time the appliance will play a sound signal and the display will show *END*.

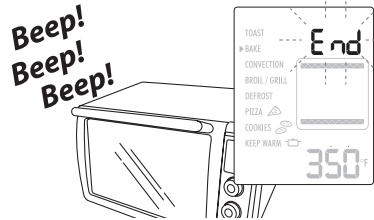

To turn the appliance off during running function or reset the control at end of time when *END* is showed on display, press the START/STOP button (H) for 2 seconds. Open the door and remove the food. Take great care when taking the food out of the oven. Use oven gloves.

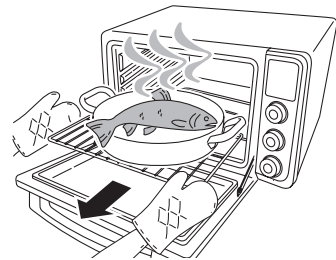

While BAKE function is running, it is possible to switch the function between CONVECTION and BROIL/GRILL without stop the cooking process. Just turn the FUNCTION selection dial (O) to select the desired new function. Timer and set temperature will be kept between BAKE and CONVECTION. For BROIL/GRILL function, the timer will be kept and temperature is auto selected.



## CONVECTION

Press any button (H L N) or turn any dial (G M O).

The oven turns on. The default selected function is TOAST.

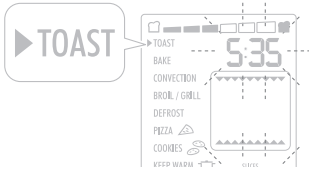

Turn the FUNCTION selection dial (O) to set the CONVECTION mode.

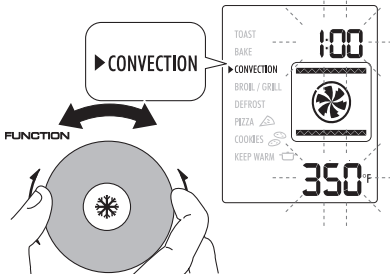

Turn the TEMPERATURE/PIZZA SIZE/SLICES/TRAY dial (M) to set the desired temperature. The default temperature is 350 °F.

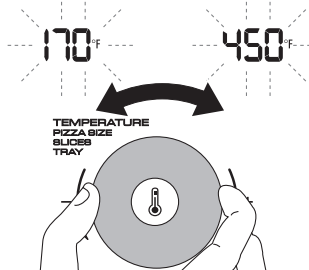

Turn the TOAST COLOUR/TIME dial (G) to set the desired timer. The default time is 1:00 (hour).

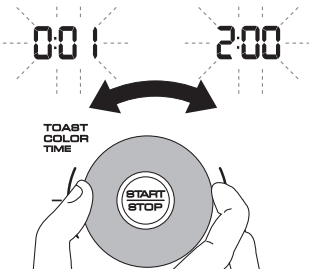

Press the START/STOP button (H) to start cooking. The red ON light (I), that is located around the edge of the START/STOP button (H), turns on.

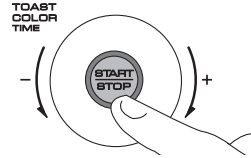

The oven starts the preheating phase. *PRE HEAT* message is shown on display. When the oven reaches the set temperature, an audible signal will sound. The countdown will start. Place the food on the wire rack (D) or bake pan (E) and insert in the oven in position 1 or 2.

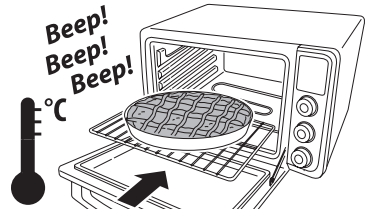

Close the door.

At the end of the set time the appliance will play a sound signal and the display will show *END*.

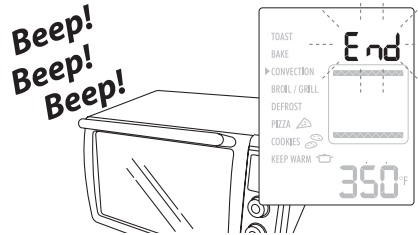

To turn the appliance off during running function or reset the control at end of time when *END* is shown on display, press the START/STOP button (H) for 2 seconds. Open the door and remove the food. Take great care when taking the food out of the oven. Use oven gloves.

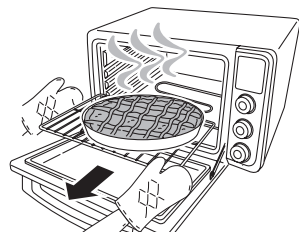

While CONVECTION function is running, it is possible to switch the function between BAKE and BROIL/GRILL without stop the cooking process. Just turn the FUNCTION selection dial (O) to select the desired new function. Timer and set temperature will be kept between CONVECTION and BAKE. For BROIL/GRILL function, the timer will be kept and temperature is auto selected.

## BROIL/GRILL

Place the food on the wire rack (D) and insert in the oven.

**No preheat is needed.**

The wire rack (D) and the bake pan (E) must be positioned as shown in the figure (position 3 and 4).

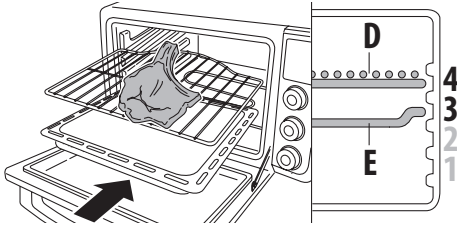

Close the door.

Press any button (H L N) or turn any dial (G M O).

The oven turns on. The default selected function is TOAST.

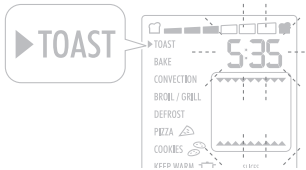

Turn the FUNCTION selection dial (O) to set the BROIL/GRILL mode.

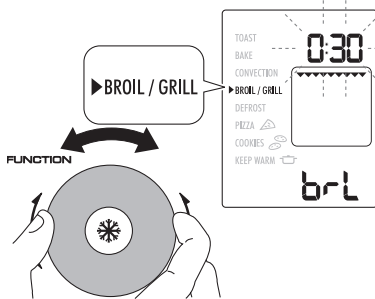

Turn the TOAST COLOR/TIME dial (G) to set the desired timer.

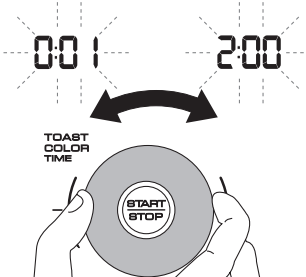

Press the START/STOP button (H) to start cooking.

The red ON light (I), that is located around the edge of the

START/STOP button (H), turns on.

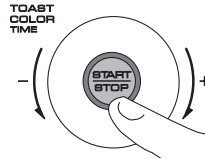

Close the door. The oven starts the cooking process.

Turn the food halfway through cooking.

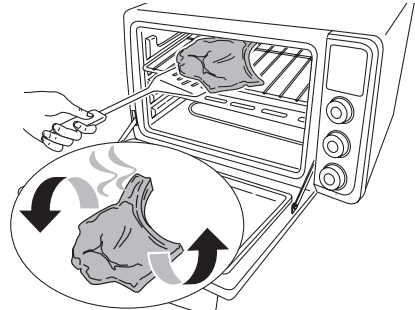

At the end of the set time the appliance will play a sound signal and the display will show *END*.

**Beep!  
Beep!  
Beep!**

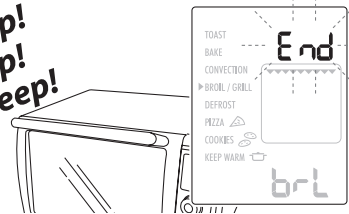

To turn the appliance off during running function or reset the control at end of time when *END* is shown on display, press the START/STOP button (H) for 2 seconds. Open the door and remove the food. Take great care when taking the food out of the oven. Use oven gloves.

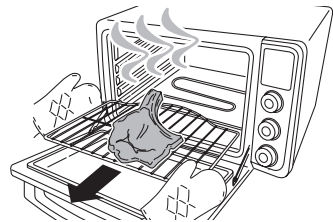

While BROIL/GRILL function is running, it is possible to switch the function between CONVECTION and BAKE without stop the cooking process. Just turn the FUNCTION selection dial (O) to select the desired new function. Timer will be kept between BAKE and CONVECTION, and set temperature will be automatically selected to default (350 °F). For BROIL/GRILL function, the timer will be kept and temperature is auto selected.

## \* DEFROST

Make sure that the oven has completely cooled down at room temperature before start this function.

Place the frozen food on the wire rack (D) or bake pan (E) and insert in the oven in position 1.

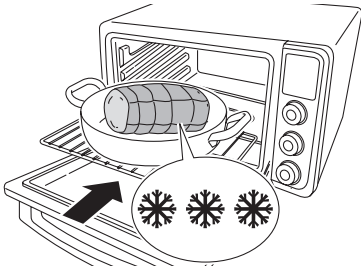

Close the door.

Press any button (H L N) or turn any dial (G M O).

The oven turns on. The default selected function is TOAST.

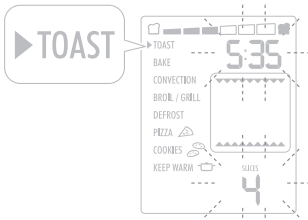

Turn the FUNCTION selection dial (O) to set the DEFROST mode.

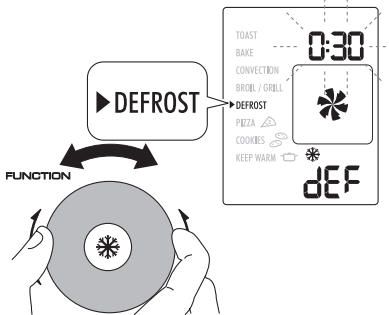

Turn the TOAST COLOR/TIME dial (G) to set the desired timer.

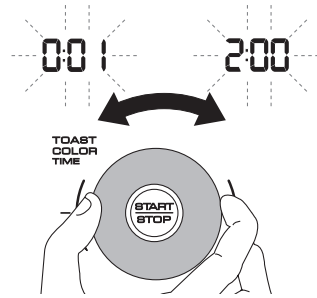

Press the START/STOP button (H) to start cooking.

The red ON light (I), that is located around the edge of the START/STOP button (H), turns on.

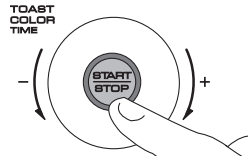

Close the door.

The oven starts the cooking process.

At the end of the set time the appliance will play a sound signal and the display will show *END*.

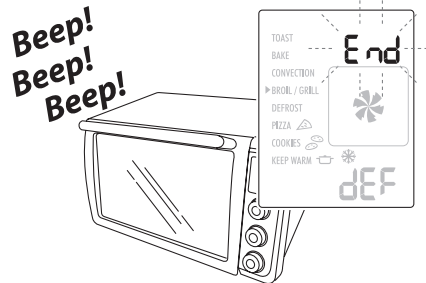

To turn the appliance off during running function or reset the control at end of time when *END* is showed on display, press the START/STOP button (H) for 2 seconds.

Open the door and remove the food.

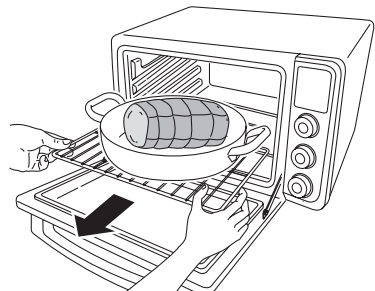



## PIZZA

Pizza is special automatic function that incorporate preset programs. Temperature, cooking time and cooking mode are automatically selected. Cooking time is extendible to desired cooking results, at the end of cooking process.

Place the pizza on the pizza pan (Q) or directly on the wire rack (D) and insert in the oven in position 1.

**No preheat is needed.**

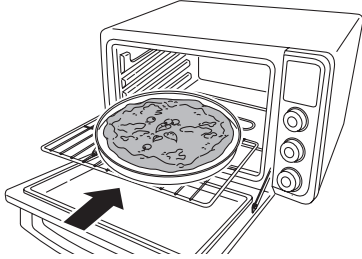

Close the door.

Press any button (H L N) or turn any dial (G M O).

The oven turns on.

The default selected function is TOAST.

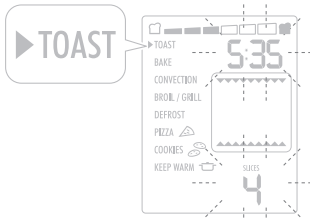

Turn the FUNCTION selection dial (O) to set the PIZZA program. Default mode is "FROZEN".

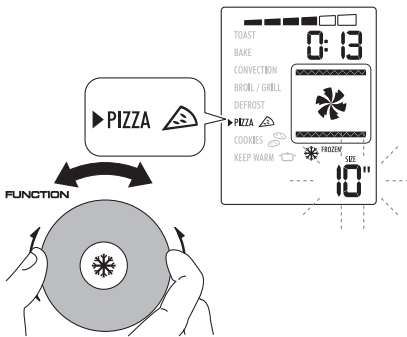

Pressing FROZEN option button (N) is possible to disable the 'FROZEN' option, to cook 'FRESH' pizza.

Further pressing will return 'FROZEN' mode.

FUNCTION

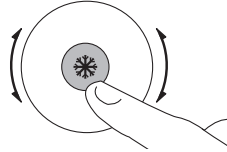

Turn the TEMPERATURE/PIZZA SIZE/SLICES/TRAY dial (M) to set the desired pizza size.

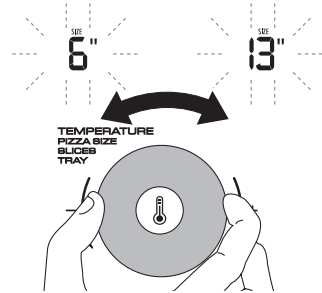

Set the desired level of crusting by turning the TOAST COLOR/TIME dial (G).

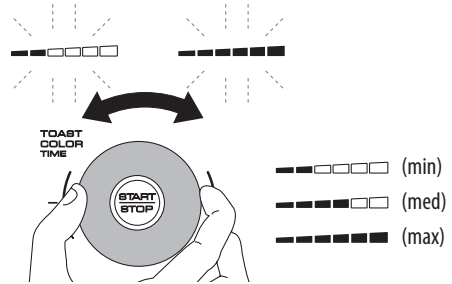

For thin pizza we suggest min crust level. For thick pizza we suggest max level of crust.

Press the START/STOP button (H) to start cooking.

The red ON light (I), that is located around the edge of the START/STOP button (H), turns on.

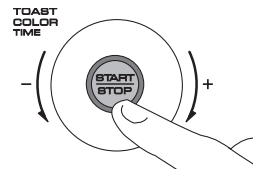

The oven starts the cooking process.

During cooking 'FRESH' pizza only, the oven will play a sound signal. It is signal to add mozzarella or soft cheese to topping your pizza.



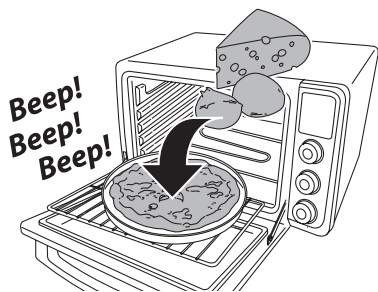

Close the door and complete the cooking process. At the end of the set time the appliance will play a sound signal and the display will show **00:00** flashing. The control is now in 'waiting mode'. In this state you can add up to 10 minutes, if necessary, to complete the cooking. This state is kept for 5 minutes, after that the control will turn off the oven automatically.

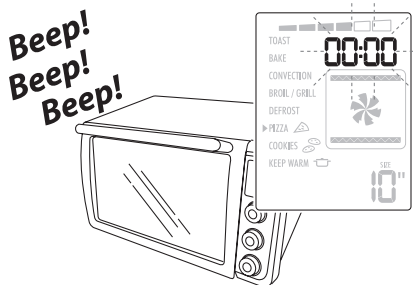

Turn the TOAST COLOR/TIME dial (G) to adjust up to 10 additional minutes, if necessary, and press the START/STOP button (H) at the end of time, the control will turn off the oven. To turn the appliance off during running function or reset the control at end of time when **END** is showed on display, press the START/STOP button (H) for 2 seconds. Open the door and remove the food. Take great care when taking the food out of the oven. Use oven gloves.

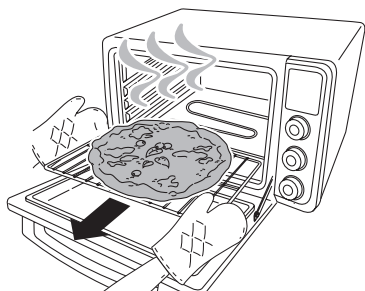

## Cooking 2 'frozen' pizza

Is possible to cook 2 'FROZEN' pizza at same time as shown in figure (position 1 and 3).

For cooking 2 pizza set the size of single one, than set the crust level at maximum.

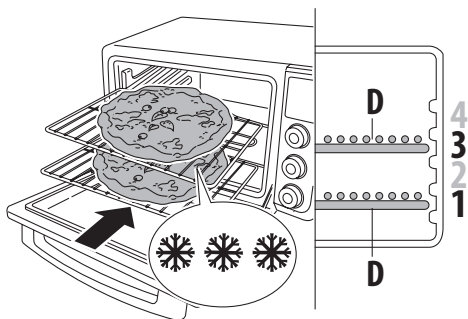

At half cooking time, turn the two pizza, placing the top one on the bottom rack and vice-versa.

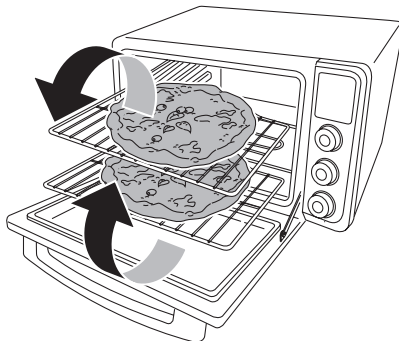



## COOKIES

Cookies is special automatic function that incorporate preset programs. Temperature and cooking mode are automatically selected. Cooking time is anyway adjustable to desired cooking results.

Press any button (H L N) or turn any dial (G M O).  
The oven turns on.

The default selected function is TOAST.

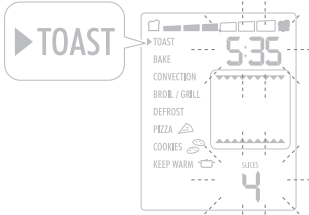

Turn the FUNCTION selection dial (O) to set the COOKIES mode.

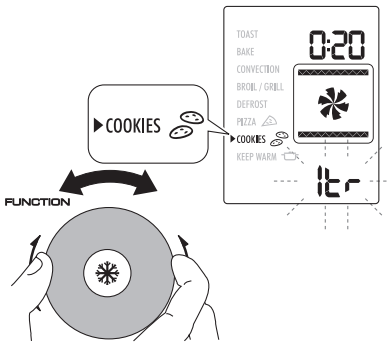

Turning TEMPERATURE/PIZZA SIZE/SLICES/TRAY dial (M) is possible to select "1tr" mode (1 tray of biscuits) or "2tr" mode (2 trays of biscuits).

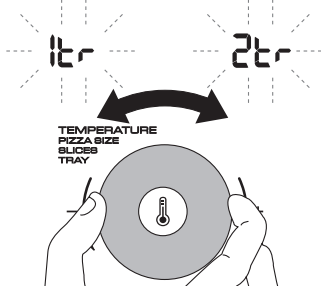

To modify the preset time, turn the TOAST COLOR/TIME dial (G) to set the desired timer.

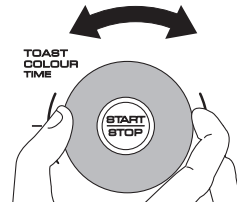

Press the START/STOP button (H) to start cooking.

The red ON light (I), that is located around the edge of the START/STOP button (H), turns on.

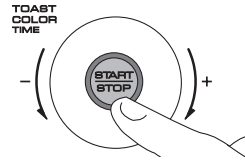

The oven starts the preheating phase and the display will show *PRE HEAT*.

When the oven reaches the set temperature, an audible signal will sound.

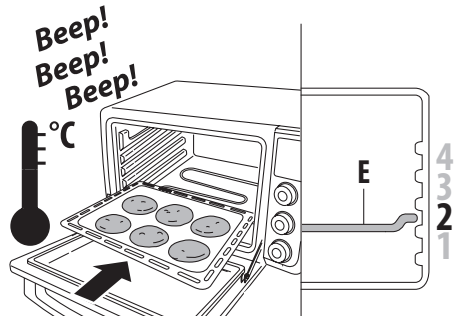

Place the food on the bake pan and insert in the oven (pos. 2).  
To cook two trays of biscuits at same time, place the wire racks covered by aluminium foil as shown (position 1 and 3).

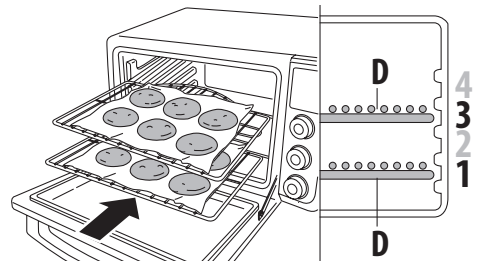

During two trays cooking mode the oven will play 3 beeps. It is signal to turn the trays, placing the top one on the bottom and viceversa and press and press the START/STOP button (H).

The oven restart the cooking function.

If START/STOP button (H) is not pressed within 15 minutes, the

oven will automatically restart the function.

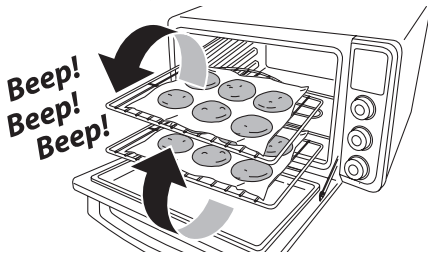

At the end of the set time the appliance will play a sound signal and the display will show 00:00.

The control is now in 'waiting mode'. In this state you can add up to 10 minutes, if necessary, to complete the cooking.

This state is kept for 5 minutes, after that the control will turn off the oven automatically.

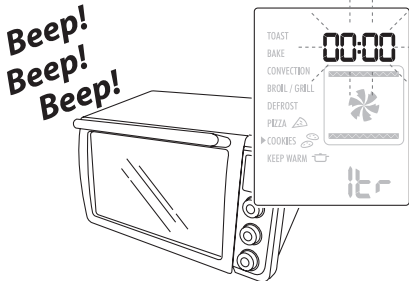

Turn the TOAST COLOUR/TIME dial (G) to adjust up to 10 additional minutes, if necessary, and press the START/STOP button (H) at the end of time, the control will turn off the oven.

To turn the appliance off during running function or reset the control at end of time when *END* is showed on display, press the START/STOP button (H) for 2 seconds.

Open the door and remove the food. Take great care when taking the food out of the oven. Use oven gloves.

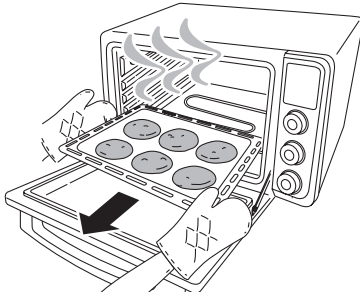

## KEEP WARM

Place the food previously cooked on the wire rack or on the bake pan and insert in the oven.

The wire rack or the bake pan must be positioned as shown in the figure (position 1).

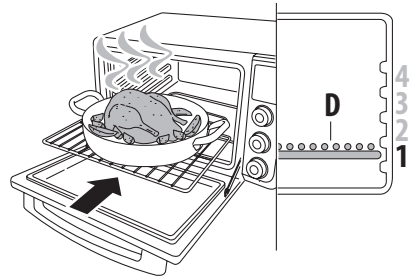

Close the door.

Press any button (H L N) or turn any dial (G M O).

The oven turns on.

The default selected function is TOAST.

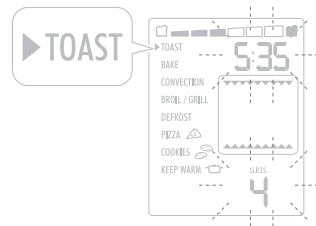

Turn the FUNCTION selection dial (O) to set the KEEP WARM mode.

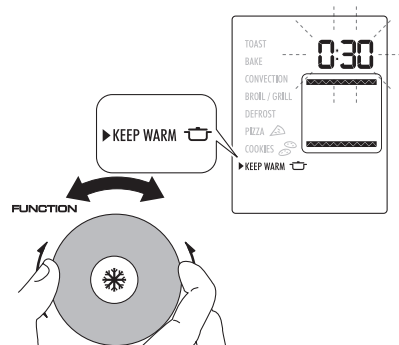

Turn the TOAST COLOUR/TIME dial (G) to set the desired timer. The default time is 0:30 (minutes).

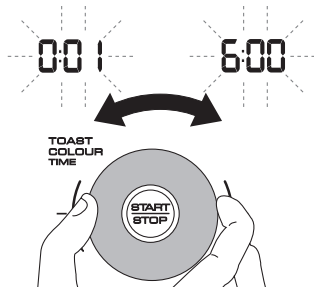

Press the START/STOP button (H) to start cooking. The red ON light (I), that is located around the edge of the START/STOP button (H), turns on.

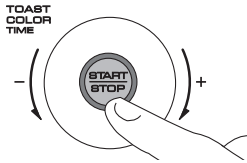

At the end of the set time the appliance will play a sound signal and the display will show *END*.

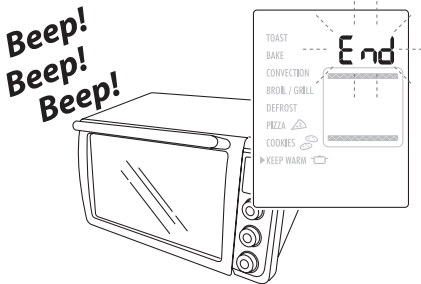

To turn the appliance off during running function or reset the control at end of time when *END* is showed on display, press the START/STOP button (H) for 2 seconds.

Open the door and remove the food. Take great care when taking the food out of the oven. Use oven gloves.

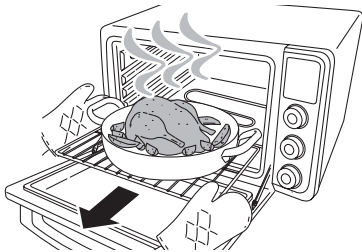

### Slow cooker

The keep warm function, thanks its low and accurate temperature regulation, can be also used as a slow cooker. In this function the time can be set up to 6 hours.

### CARE AND CLEANING

Frequent cleaning prevents the formation of smoke and bad odors during cooking. Do not let fat and food residues accumulate inside the appliance.

Before any maintenance or cleaning operation, unplug the oven and wait for it to cool down.

Clean the door, the inside walls and surfaces of the oven with a soap and water solution; dry thoroughly. Never use steel wool or abrasive sponges for cleaning.

To clean the aluminum surfaces on the inside of the oven, never use products that corrode aluminum (detergents in spray cans) and never scrape the walls with sharp objects.

Never use corrosive or aggressive detergents.

To clean the outside surface always use a damp sponge.

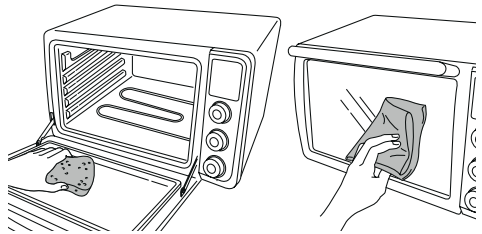

Avoid using abrasive products that may damage the exterior.

Make sure water or liquid soap does not seep into the vents on the top of the oven.

Never immerse the appliance in water; never wash it under a jet of water.

Never use flammable liquids for cleaning.

All accessories are washed like normal dishes, either by hand or in the dishwasher, except crumb tray.

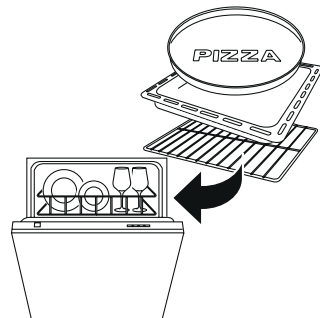

Slide the crumb tray (R) out from the bottom of your oven. Wash by hand. Should the dirt be difficult to remove, rinse the crumb tray with hot soapy water and if necessary, scour it delicately, without scratching it. Carefully dry after operation.

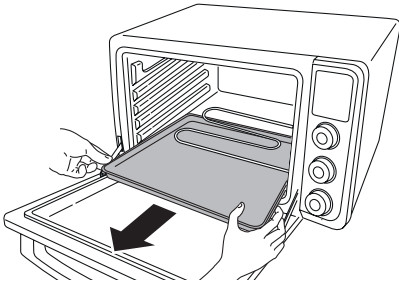

When the oven is on, the internal light (B) inside the oven is always on.

To replace the bulb, proceed as follows: ensure that the appliance has cooled down, **unplug the appliance from the power outlet**, unscrew the glass cover and replace the bulb with a new one of the same type (resistant to high temperatures) and then replace the glass cover.

Bulb type: E14, 15W, 300 °C.

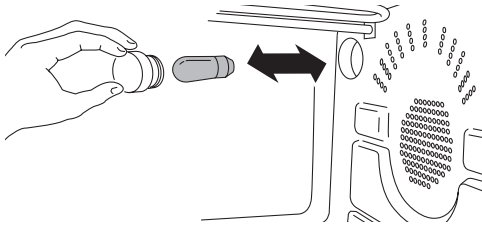

Never place heavy weights over the door when it is open, in order to avoid damages on its structure and the glass.

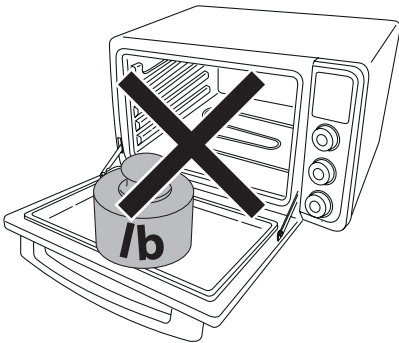









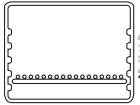



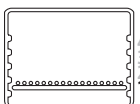



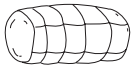



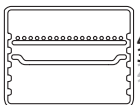





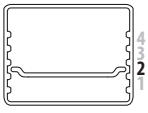

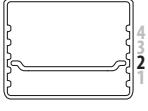

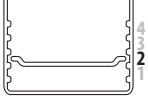
## Disposal

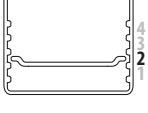
When disposing of appliance, follow local regulations of your state.

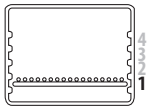
Consumers should contact their local authority or retailer for information concerning the correct disposal of their old appliance.

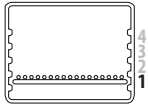
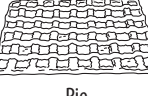
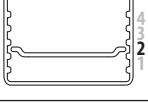
## RECIPES LIST

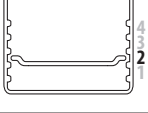
RECIPES	WEIGHT	WIRE RACK AND BAKE PAN POSITION	FUNCTION	TEMPERATURE	TIME
 Quiche	1.5 lb 700g	 1	CONVECTION	390 °F 200 °C	30-35 min
 Bread	1.0 lb 500g	 2	CONVECTION	360 °F 180 °C	35-40 min
 Cannelloni	3.3 lb 1500g	 1	BAKE	360 °F 180 °C	35-40 min
 Chicken	5.5 lb 2500g	 1	CONVECTION	375 °F 190 °C	90-100 min
 Chicken piece	3.3 lb 1500g	 1	CONVECTION	375 °F 190 °C	40-45 min
 Roast	2.2 lb 1000g	 1	CONVECTION	375 °F 190 °C	75-80 min
 Meat and vegetable kebabs	2.2 lb 1000g	 2	CONVECTION	360 °F 180 °C	55-60 min
 Meat	1.2 lb 550g	 4 3	BROIL/GRILL	Auto selected	25-30 min
 Fish	2.2 lb 1000g	 2	BAKE	400 °F 200 °C	30-35 min

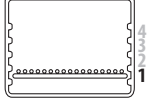
RECIPES	WEIGHT	WIRE RACK AND BAKE PAN POSITION	FUNCTION	TEMPERATURE	TIME
 *** Frozen potatoes	2.2 lb 1000g		CONVECTION	400 °F 200 °C	55-60 min
 Fresh potatoes	2.2 lb 1000g		CONVECTION	400 °F 200 °C	50-55 min
 Tomato gratin	2.2 lb 1000g		BAKE	400 °F 200 °C	25-30 min
 *** Frozen brioche	6		CONVECTION	340 °F 170 °C	25-30 min
 Sponge cake	1.5 lb 700g		BAKE	340 °F 170 °C	25-30 min
 Cake	1.6 lb 750g		BAKE	360 °F 180 °C	30-35 min
 Pie	2.2 lb 1000g		BAKE	360 °F 180 °C	30-35 min
 Muffins	12		BAKE	340 °F 170 °C	20-25 min
 Plum cake	2.0 lb 900g		BAKE	300 °F 150 °C	85-90 min

## TROUBLESHOOTING

ERROR MESSAGE ON DISPLAY	DESCRIPTION	POSSIBLE PROBLEMS	SOLUTION
E0:11 Err	Temperature probe malfunction	The electronic control detected a malfunction on temperature probe	Record the error number. Reset the control by pressing START/STOP button (H) for 2 seconds and disconnect the plug from wall outlet. The temperature probe need to be replaced. Contact a De'Longhi customer service reporting the error number.
E0:12 Err	Temperature probe malfunction	The electronic control detected a malfunction on temperature probe	Record the error number. Reset the control by pressing START/STOP button (H) for 2 seconds and disconnect the plug from wall outlet. The temperature probe need to be replaced. Contact a De'Longhi customer service reporting the error number.
E0:21 Err	Target temperature not reached: The oven cannot reach the target temperature in a reasonable time range	The electronic control detected an excessive time to reach the target temperature inside the oven	Record the error number. Reset the control by pressing START/STOP button (H) for 2 seconds and disconnect the plug from wall outlet. First check that the oven door has been closed during the use. If door is kept open while in use , the oven cannot reach the target temperature. If oven door was properly closed, the heating elements could be damaged. Contact a De'Longhi customer service reporting the error number.
E0:22 Err	Over temperature: The oven reaches excessive temperature	The electronic control detected an excessive temperature inside the oven	Record the error number. Reset the control by pressing START/STOP button (H) for 2 seconds and disconnect the plug from wall outlet. The electronic control could be damaged. Contact a De'Longhi customer service reporting the error number.
E0:27 Err	Unexpected heating: The temperature probe detected a temperature rise when heating elements should be OFF	The electronic control detected an unexpected temperature rise inside the oven, when heating elements should be not energized	Record the error number. Reset the control by pressing START/STOP button (H) for 2 seconds and disconnect the plug from wall outlet. This error may be showed when the oven start the DEFROST function when it is still warm from a previous cooking process. Let the oven cool down before start the DEFROST function. If above case was not, the electronic control could be damaged. Contact a De'Longhi customer service reporting the error number.



<b>POSSIBLE PROBLEMS</b>	<b>SOLUTION</b>
Oven will not switch ON	<ul style="list-style-type: none"> <li>- Check that the power plug is properly inserted into wall outlet</li> <li>- Insert the power plug into a different outlet</li> <li>- Verify the circuit breaker</li> </ul> <p>If above solution do not solve the problem , probably the oven had a malfunction. Contact a De'Longhi customer service.</p>
LCD display light has gone out	<p>The oven goes in standby mode , when not used for 30 seconds , if Clock was not set. When Clock is set , the display light is kept ON</p>
Clock setting has gone out	<p>If the LCD display light has gone out even if Clock was previously set , a power supply interruption greater than 5 seconds occurred. The electronic control has been resetted. Set the Clock again.</p>
Oven lamp is OFF while oven is ON	<ul style="list-style-type: none"> <li>- The bulb is broken. Replace the bulb.</li> <li>- The bulb is not properly screwed into its housing. Verify that it is completely screwed.</li> </ul> <p>If above solution do not solve the problem , probably the electronic control of the lamp had a malfunction. Contact a De'Longhi customer service.</p>
The pizza does not cook evenly	<p>Some large pizza , or particular dough pizza may brow unevenly .We suggest in these cases to turn half way through the cooking time the pizza for a perfect final result.</p>
Steam coming out from housing	<p>This is normal. The oven is vented to release excessive steam created from bread or high-moisture content foods.</p>
Water dripping on internal glass	<p>This is normal. The condensation created by toasting bred and frozen bred will run down the inside of door glass , and collected into a special slot on internal lower side of door.</p>

## RECIPES

---

### FRESH PIZZA

---

<b>Ingredients:</b>	<b>Quantity:</b>
water	0.44 lb (200 g)
fresh yeast	0.24 oz (7 g)
White flour W330 (or Manitoba type 0)	0.46 lb (210 g)
durum wheat flour	1.7 oz (50 g)
extra virgin olive oil	0.52 oz (15 g)
salt	0.2 oz (6 g)
mozzarella	0.22 lb (100 g)
tomato sauce	
salt	to taste
oregano	to taste

1. Prepare the pizza dough: dissolve the yeast in water in the mixer bowl, add the flour and mix for 7-8 minutes, removing the dough from the hook with a spatula every once in a while.
2. Add the salt a bit at a time and then add the oil in a stream. When the oil has been completely absorbed, set the dough on an oiled surface and form into a ball using your hands.
3. Place it in a large, lightly oiled bowl, cover with plastic wrap or with a clean cloth and let rise in a warm place away from air currents.
4. Wait until the dough has at least doubled in volume (about an hour and a half) and then spread out the pizza. Place the dough on a lightly floured surface and spread out using your hands. Thoroughly oil the pizza plate provided, spread the dough over it and top with the tomato sauce, a pinch of salt, and the oregano.
5. Insert the pizza plate in the oven above the grill inserted in guide 1. Select the PIZZA function, set the time to 13" and press the START/STOP button (H).
6. At 6 minutes from the end, the oven will beep. Add the cubed mozzarella and continue cooking.
7. When finished cooking, serve.

### LASAGNE ALLA BOLOGNESE

---

<b>Ingredients:</b>	<b>Quantity:</b>
Fresh lasagna,	10 sheets
Béchamel sauce	33.81 oz (1 l)
meat sauce	1.1 lb (500 g)
parmigiano cheese	0.22 lb (100 g)

1. First prepare the meat sauce and Béchamel separately.
2. Now start putting the lasagna together in a 30x20 cm rec-

tangular baking dish. Spread a layer of Béchamel sauce in the dish, making sure it is uniform and covers the entire surface. Place a layer of lasagna noodles and then another thin layer of Béchamel sauce.

3. Now spread a layer of meat sauce and the grated cheese, making sure you cover the entire surface of the dish. Continue in layers until you have used all of the ingredients. Finish with a layer of meat sauce and a thick sprinkling of parmigiana cheese.
4. Select the BAKE function, set the temperature to 360°F and the time to 40 minutes the press the START/STOP button (H). The oven starts the pre-heating phase. Once the temperature is reached the display will show the cooking time. Insert the tray above the grill inserted in guide 1 and cook for the set time.
5. At the end, take it out of the oven and allow to cool before serving.

### CHICKEN ROULADES STUFFED WITH CHEESE AND SPINACH

---

<b>Ingredients:</b>	<b>Quantity:</b>
chicken breast	4
sliced cheese	2
precooked spinach	0.44 lb (200 g)
extra virgin olive oil	to taste
salt and pepper	to taste
sage leaves	to taste
rosemary	to taste

1. Beat each chicken breast lightly with the meat tenderizer. Season with salt, pepper, and minced rosemary and sage. On each one place spinach and the cheese slices cut into strips.
2. Roll up the chicken slices and fasten with a toothpick or some kitchen twine.
3. Cover the pan with baking paper and place the roulades on top.
4. Select the CONVECTION function, set the temperature to 375°F and the cooking time to 30 minutes. Press the START/STOP button (H). The oven starts the pre-heating phase.
5. Once the temperature is reached the display will show the cooking time. Insert the pan in guide 2 and cook for the set time.
6. Serve sliced.

## ROASTED PORK SHANK WITH SESAME POTATOES AND GINGER ONION CREAM

Ingredients:	Quantity:
Pork shank	
(2 whole, cut in half length-wise)	3 lb (1400 g)
organic red potato	1.1 lb (500 g)
mix of celery, carrot, and onion	to taste
garlic,	2 pc.
Dijon mustard,	1 Tablespoon
cloves	6
sage, rosemary	to taste
extra virgin olive oil	0.1 oz (3 g)
onion	0.33 lb (150 g)
fresh ginger	1 oz (30 g)
salt and pepper	to taste

1. One day ahead of time (recommended), marinate the shanks with the mustard, 2 tablespoons of oil, the ground cloves, garlic, aromatic herbs, a glass of dry white wine, salt, and pepper.
2. Mince the carrots, celery, and onion then mix it with the meat and put everything on the pan.
3. Insert the pan in guide 1, close the door, and set the oven in KEEP WARM function for 4 hours.
4. In the meantime, wash the potatoes in baking soda then cut them in 3x3 cm cubes.
5. Boil the potatoes in salted water until al dente then remove them and season with salt, pepper, oil, and sesame oil.
6. Chop the onions and cook in 500g of water until creamy then add the grated ginger and sprinkle in the rice flour and blend well. Add salt if necessary. The sauce must have a creamy consistency. If necessary, reduce it over heat.
7. Remove the shanks from the oven then remove and set aside the vegetables and cooking juices. Add the potatoes to the pan
8. Blend the drippings previously left aside with a small amount of extra virgin olive oil.
9. Select the CONVECTION function, set the temperature to 450°F and the cooking time to 30 minutes. Press the START/STOP button (H). The oven starts the pre-heating phase.
10. Once the temperature is reached the display will show the cooking time. Insert the pan in guide 2 and cook for the set time.
11. Once the shanks are brown, remove them from the oven and serve with the two prepared sauces.

## MEDITERRANEAN SEA BREAM

Ingredients:	Quantity:
sea bream	2
cherry tomatoes	0.44 lb (200 g)
black olives	0.22 lb (100 g)
1 garlic clove	
thyme	to taste
salt	to taste
pepper	to taste
olive oil	to taste

1. First remove the scales from the sea bream, wash and dress. Salt and pepper inside the belly, add a clove of garlic and two sprigs of thyme.
2. Pour the oil inside the tray and arrange the two sea bream on top.
3. Cut the cherry tomatoes in half and put them inside the tray along with the black olives then sprinkle everything with salt.
4. Select the BAKE function, set the temperature to 400°F and the cooking time to 35 minutes. Press the START/STOP button (H). The oven starts the pre-heating phase.
5. Once the temperature is reached the display will show the cooking time. Insert the pan in guide 2 and cook for the set time.
6. Serve.

## JAM TART

Ingredients:	Quantity:
flour	0.55 lb (250 g)
sugar	0.24 lb (110 g)
butter	0.27 lb (125 g)
eggs	1 whole + 1 yolk
salt	1 pinch
jam	0.44 lb (200 g)

1. Mix all of the ingredients (except the jam) in a food processor. Put about 1/3 of the dough aside to use as decoration.
2. Roll out the rest of the dough and line a previously buttered and floured cake tin.
3. Add the jam and use the rest of the dough to decorate with criss-crossed strips.
4. Select the BAKE function, set the temperature to 360°F and the cooking time to 35 minutes. Press the START/STOP button (H). The oven starts the pre-heating phase.
5. Once the temperature is reached the display will show the cooking time. Insert the cake tin above the grill inserted in guide 1 and cook for the set time.

## SPONGE CAKE

---

<b>Ingredients:</b>	<b>Quantity:</b>
eggs	6
sugar	0.41 lb (190 g)
flour 00	0.33 lb (150 g)
potato starch	0.16 lb (75 g)
vanillin	0.07 oz (2 g)

1. Beat the eggs and sugar in a bowl until they are thick and foamy. Now add the sifted flour, starch and vanillin and mix with a whisk until completely mixed, making sure not to whip it.
2. Butter and flour a 26 cm cake tin and pour the batter in the centre, making sure it is level.
3. Select the BAKE function, set the temperature to 340°F and the cooking time to 30 minutes. Press the START/STOP button (H). The oven starts the pre-heating phase.
4. Once the temperature is reached the display will show the cooking time. Insert the cake tin above the grill inserted in guide 1 and cook for the set time.

## PLUM CAKE

---

<b>Ingredients:</b>	<b>Quantity:</b>
butter	0.55 lb (250 g)
sugar	0.55 lb (250 g)
eggs	3 whole + 2 yolks
flour	0.55 lb (250 g)
raisins	0.17 lb (80 g)
rum	1 cup
salt	1 pinch

1. Cream the butter (which must be removed from the refrigerator at least 2 hours ahead of time) with the sugar until the batter is white.
2. Add the eggs one at a time, then at the flour a little at a time and a pinch of salt. Then add the rum and raisins (after soaking for 30 minutes in warm water).  
The raisins must be squeezed dry and then floured so they do not fall to the bottom of the tin during cooking.
3. Pour the mixture into a rectangular pan that was previously buttered and floured.
4. Select the BAKE function, set the temperature to 300°F and the cooking time to 90 minutes. Press the START/STOP button (H). The oven starts the pre-heating phase.
5. Once the temperature is reached the display will show the cooking time. Insert the plum cake pan above the grill inserted in guide 1 and cook for the set time.

## CHOCOLATE-NUTS CHIPS COOKIES

---

<b>Ingredients:</b>	<b>Quantity:</b>
peeled hazelnuts	0.24 lb + 0.11 lb (110 g + 50 g)
brown sugar	0.11 lb (50 g)
soy milk	1.69 oz (50 ml)
faro flour	0.88 oz (25 g)
powdered cocoa	0.17 oz (5 g)
corn starch	0.35 oz (10 g)
dark chocolate chips	0.52 oz (15 g)

1. Chop the hazelnuts with the sugar in the food processor until very fine
2. Sift the flour with the starch and cocoa then add the chopped hazelnuts and then the chocolate. Add the soy milk and mix the dough until it is smooth and wet.
3. Put the bowl in the refrigerator for at least an hour to thicken the dough so that it can be worked by hand.
4. Work the dough, making strips and then chunks of dough that should be shaped into spheres and put on two grills with baking paper. Flatten the balls with a fork and sprinkle hazelnuts on top.  
Select the COOKIES function and set 2TR.  
Press the START/STOP button (H).
5. When the temperature has been reached the oven will go into stand-by mode and the cooking time will flash on the display. Insert the grills in guides 1 and 3, set 20 minutes and press the START/STOP button (H).
6. About halfway through cooking the oven will beep and the cooking time will flash. Switch the two grills and press the START/STOP button (H).
7. Serve the cookies.