

Front Load Washer

EIFLS60L SS

IQ-Touch™ Electronic Controls Featuring Perfect Steam™



Silver Sands
EIFLS60L SS



Optional Luxury-Glide™
Touch-2-Open™
Pedestals Shown in
Available Colors.



Cleanest Front Load Wash¹

Our front load washer offers exclusive technology that gets your clothes the cleanest.



Fastest Wash Time²

Fifteen minutes to wash.



Sure-2-Fit® Capacity Washer

Wash more in one load with our large capacity washer.



ENERGY STAR® Most Efficient³

Recognized as the Most Efficient of ENERGY STAR® in 2012.



27" ELECTRIC FRONT LOAD WASHERS

Capacity D.O.E.	4.30 Cu. Ft.
-----------------	--------------

Features

Door Design	Signature Soft-Arc
Electronic Controls	IQ-Touch™ with LCD Display
Perfect Steam™ Wash System	Yes
Balance System	Perfect Balance®
Sound System	Luxury-Quiet™
Lighting	Luxury-Design®
Touch-2-Open™/(Close) Door	Yes
Touch-2-Open™/(Close) Dispenser Drawer	Luxury-Glide®
Wash System	ExpertCare™
Integral Water Heater	Yes
Wash Drum	Stainless Steel
Automatic Temperature Control	Yes
Automatic Water Level Adjustment	Yes
Auto Prewash Detergent Dispenser (Liquid/Powder)	Yes
Auto Bleach Dispenser (Liquid Only)	Yes
Auto Detergent Dispenser (Liquid/Powder)	Yes
Auto Fabric Softener Dispenser (Liquid Only)	Yes
Tumble Speed (RPM)	Variable
Spin Speed (RPM)	1,300
Reversible Door	Yes
Adjustable Leveling Legs	Yes
ENERGY STAR®	Most Efficient ³
NSF® Certified	Sanitize/Allergen

Cycles

Fast Wash™, My Favorite (1), Deep Clean Sanitize™, Heavy Duty™, Whitest Whites™, Colors™, Normal™, Casual™, Delicates, Allergen™, Spin Only, Rinse & Spin (Can be used with Add Steam option)	11
Specialty Cycles – Jeans, Fast Sanitize, Stuffed Animals, Pet Beds, Clean Washer, Active Wear, Fast Steam	7

Options

Wash/Rinse Temperature Combinations	9
Temperature Selections	5
Add Steam	7
Spin Speed Selections	5
Soil Level Selections	5
Delay Start (Hours)	22
End-of-Cycle Chime	Adjustable

Installation Options

Freestanding, Under Counter*, Stacked (Under Dryer), Pedestal, Hidden (In Closet), Second Floor	Yes
---	-----

Accessories

Luxury-Glide® Touch-2-Open™/(Close) Pedestal – SS – PN# EPWD15SS	Optional
Dryer Stacking Kit – PN# STACKIT4X	Optional
Drain Hose Extension Kit – PN# 137098000	Optional
Mobile Home Installation Kit – PN# 137067200	Optional

Specifications

Color –	
Silver Sands	SS
Product Dimensions –	
Height Without 15" Pedestal	38"
(With 15" Pedestal)	53"
Width	27"
Depth (to Center of Arc Not Including Hose)	31-1/2"
(with 90° Door Open)	50-5/8"
Power Supply / Water Inlet Location	Top Right Rear / Top Left Rear
Voltage Rating	120V/60 Hz/15A
Connected Load (kW Rating) @ 120 Volts ²	1.2
Watts @ 120 Volts	1200
Amps @ 120 Volts	12
Shipping Weight (Approx.)	247 Lbs.

¹Side-by-Side units in under-counter installation require custom-built countertop and/or cabinetry.

²An electrical supply with grounded three-prong receptacle is required. The power supply circuit must be installed in accordance with current edition of National Electrical Code (NFPA 70) and local codes & ordinances.

NOTE: Always consult local and national electric & plumbing codes. Refer to Product Installation Guide for detailed installation instructions on the web at electroluxappliances.com.

Specifications subject to change.

³Based on AHAM washability test protocol for leading brand front load washers with normal cycle times less than 60 minutes.

²Fastest time based on smallest load/Fast Wash and Fast Dry cycles selected for various load compositions.

³Recognized as the Most Efficient of ENERGY STAR® in 2012.

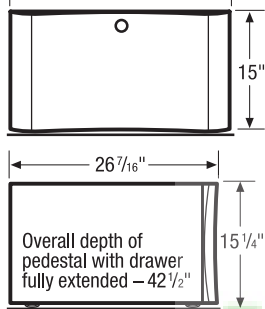
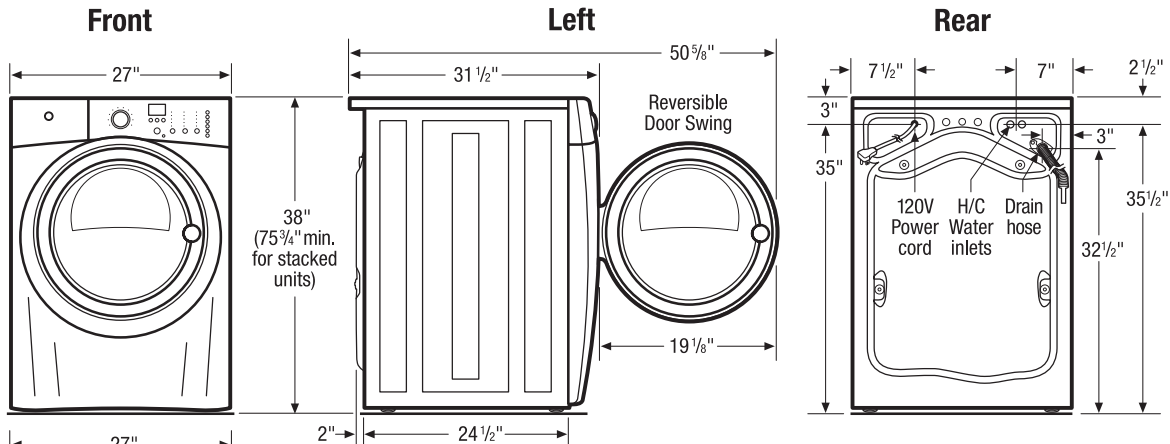

15" Drawer Pedestal Installation

Elevates washer height to 53". For detailed pedestal installation, refer to instructions included with pedestal or on web. **Note:** Pedestal Installation requires modified utility hookup locations. For details, refer to Product Installation Guide on web.

Built-In Installations

For built-in installations, NO minimum clearance required around sides and backs of units. (Steam dryers only will require 3/4" steam hose clearance at back of unit.) For closet installation, allow 1" clearance between fronts of units and door. Location of plumbing, exhaust and utility hookups MUST be considered in built-in installations. For additional installation details, refer to Product Installation Guides on web.

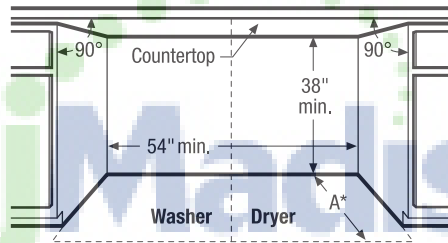

Side-by-Side Units in Under-Counter Installation
Requires custom-built countertop and/or cabinetry.

A - 31 1/2" (with non-steam dryer) / 32 1/4" (with steam dryer)

* To achieve minimal depth dimensions or clearances, dryer MUST be vented straight back or with quick-turn 90° elbow.

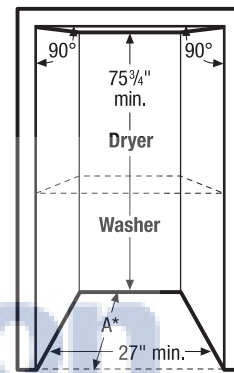

Stacked Units in Recessed or Closet Installation

For detailed stacked installation, refer to instructions included with Stacking Kit or on web. **Note:** Stacked installation requires modified utility hookup locations for dryer. For details, refer to Product Installation Guide on web.

Front Load Washer Specifications

- Product Weight – 237 Lbs.
- An electrical supply with grounded three-prong receptacle is required. The power supply circuit must be installed in accordance with current edition of National Electrical Code (ANSI/NFPA 70) and local codes & ordinances. (Do not use same circuit as dryer.)
- Voltage Rating – 120V/60 Hz/15 Amps
- Amps @ 120 Volts = 12 Amps
- Connected Load (kW Rating) @ 120 Volts = 1.2 kW
- Equipped with 120V 3-wire power supply cord, approx. 60" long.
- Always consult local and national electric & plumbing codes.
- To maximize detergent effectiveness, ambient temperature should never be below 60° F.
- Can be installed alone, with or without optional 15" drawer pedestal, or stacked beneath matching Electrolux Dryer, which requires installation of optional dryer stacking kit. (For installation details, refer to instructions included with optional pedestal or stacking kit or on web.)
- Can be built in with matching Electrolux Dryer in under-counter, recessed or closet installation. Installations requiring countertop and/or cabinetry will require custom building. (Refer to Built-In Installations on this page for cutout dimensions. For additional installation details, refer to Product Installation Guide on web.)
- Closet installation requires vented door with 2 unobstructed louvered openings, minimum 60 sq. in. each, located 3" from top and bottom of door. Full-length 120 sq. in. opening also acceptable. Allow 1" clearance between door and fronts of units.

- Do NOT install in area exposed to dripping water or outdoor weather conditions, or where gasoline or other flammables, including automobiles, are kept or stored.
- Floor MUST be solid with 1" maximum slope. To ensure vibration or movement does not occur, reinforcement of floor may be necessary. Do NOT install on carpeted surface.
- Leveling legs supplied to level washer properly and reduce excessive noise and vibration.
- H/C water faucets MUST be installed within 42" of washer's water inlet and MUST be 3/4" garden hose type, to connect to 48-1/2" inlet hoses.
- Water pressure MUST be between 30 and 120 psi with NOT more than 10 psi pressure difference between hot and cold.
- Drain required with standpipe diameter of 1-1/4" min. and height of 24" min./96" max. above floor, capable of eliminating 17 gallons per minute. Attached 59" drain hose can reach 79"-high standpipe.

Note: For planning purposes only. Refer to Product Installation Guide on the web at electroluxappliances.com for detailed instructions.

Optional Accessories

- Drawer Pedestals – Silver Sands (PN # EPWD15SS).
- Dryer Stacking Kit – (PN # STACKIT4X).
- Drain Hose Extension Kit – (PN # 137098000).
- Mobile Home Installation Kit – (PN # 137067200).