

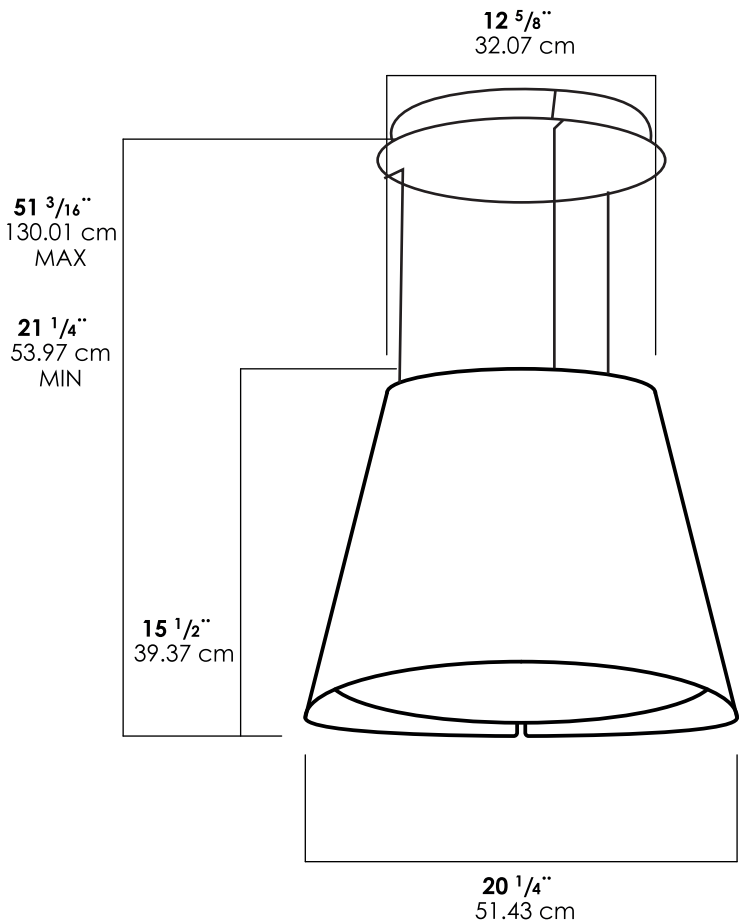

Easy brilliantly glossy finish reflects the world around it like a kaleidoscope, and provides a powerful visual impact, while the modern, clean-lined definition makes it easily adaptable to a variety of styles and environments.

Many are stunned by Easy 's pendent light appearance, touch control, LED lighting and perimeter aspiration are pleased to find its decorative qualities by a high functioning range hood hidden within.



MOUNTING  
HEIGHT  
RANGE

SPECIFICATIONS

Width:	20" UNIT	
Model:	EES320SS	EES320WT
Dimensions:	20"W x 20"D x Min 21" Max 51"H	
Blower Type(internal):**	355 CFM (3- speed+ booster)	
Noise (sones):**	6.8 Sones	
Finish:	Stainless Steel	White
Controls:	Electronic push with perimetral light	
Illumination:	3 LED Lights, 2.5 W, 4000 K	
Filter Type:	Dishwasher-Safe, Anodized Aluminum, Mesh Filter + Perimeter Aspiration	
Installation Type:	Recirculating Only	
Installment Heights:	Ceiling Hieghts 6'10" - 11'8"	
Electrical:	120 V - 60 Hz, 460 W	
KITS:		
Wall Mounting Bracket Kit:	KIT0121394	
High Ceiling Extension Kit:	KIT01921 (Can reach 6'10" - 23' 5")	
WARRANTY:***	Two (2) Years Parts & In-Home Labor. Earn an additional One (1) Year of Parts & In-Home Labor by registering on elica.com.	

PLUS FEATURES



**LED LIGHT** - LED lighting is undoubtedly the smartest solution in terms of energy saving. Expected life is over 20,000 hours, and should last the full life of the hood.



**PERIMETER ASPIRATION** - First developed by Elica, this technology literally turned the market 180 degrees and opened the door to hoods that could be mounted on the wall like picture frames. The technology draws air through a narrowed channel around a face plate, which increases suction, without increasing blower speed or energy consumption.



**CLEAN FILTER ALARM** - When activated, your hood will emit a "beep" signal to let you know when is time to clean your filters. For some models, an intermittent light will remain active until cleaning filter action is completed. See instructions manual to activate feature.



**LONG LIFE FILTER** - One-of-a-kind odour filter, capable of regenerating itself and of lasting up to 3 years, while standard filters have an average life between 3 to 6 months. To maintain these characteristics, the filter only requires simple maintenance: wash every 2 or 3 months with hot water and mild soap (also in the dishwasher at 65 degrees) and dry in the oven for 10 minutes at 100 degrees.



**ELECTRONIC TOUCH CONTROLS** - Enjoy the modern design and convenience of multi-function electronic touch controls, which are discreetly hidden behind sleek black glass, and will illuminate a soft blue when activated.



**REPLACE FILTER ALARM** - When activated, your hood will emit a "beep" signal let you know when is time to replace the carbon filters. See instructions manual to activate feature.

HVI Certified Ratings	High Speed	Working Speed	Duct Size
CFM	390	170	10" (Vertical)
Sones	7	1.5	10" (Vertical)

\* The product images shown are for illustration purposes only and may not be an exact representation of the product.

\*\* Blower performance indicates the performance of the blower by itself. Performance claims are not HVI certified but were established in accordance with HVI Standardized test procedure. For Certified Ratings, please refer to HVI Certified Product Directory. Electric Ratings are declared according to UL.

\*\*\* For valid warranty extension, register within 3 months from purchase. For USA & Canada Users Only.