



**32" Upright Built-In All-Refrigerator\* Specifications**

- Product Weight – 253 Lbs. approx.
- An electrical supply with grounded three-prong receptacle is required. The power supply circuit must be installed in accordance with current edition of National Electrical Code (NFPA 70) and local codes & ordinances.
- Power Supply Circuit – 115V/60 Hz/ 15 or 20 Amps
- Always consult local and/or national electric & plumbing codes.
- When installing next to wall where handle may make contact, allow 4" minimum clearance for 90° door swing. At 90° door stop position, drawer access will be maintained but removal will be restricted.
- Refrigerator must be placed on level surface of hard material, same height as flooring. Surface must support approximately 1500 lbs. when fully loaded. Unit equipped with 4-point leveling.

\* Shown with optional trim kit.

NOTE: Refer to Product Installation Guide for detailed instructions on the web at [electroluxusa.com](http://electroluxusa.com).

**PureAdvantage™ Filtration System**

The most advanced water filtration system available offers cleaner, fresher ice. It is simple to operate and with one touch, the drip-free cartridge can be replaced.

**Dynamic Cool™ with Easy Set™ Digital Temperature Control System**

Amazingly consistent interior temperature will keep your food fresher longer.

**Illumination Solutions**

Transition lighting that is so thoughtfully designed that it gradually illuminates the interior of the refrigerator with soft but shadowless light.

**SpillSafe™ Full-Width Glass Shelves**

3 SpillSafe™ glass shelves and can contain spills up to 24 ounces.

**Smooth-Glide™ Full-Extension System**

Crispers with adjustable dividers and deli drawer, slide in and out with ease, extending completely for convenient access to stored food.

**Gallon Door Bin**

The full-width gallon bin offers maximum storage capacity in the door.

**Stainless Steel Trim Kits**

Order stainless steel trim kits, for built-in individual or side-by-side configuration, including black 4" riser with leveling system, top grill, toe kickplate and side trim pieces for an integrated look.

**32" UPRIGHT BUILT-IN ALL-REFRIGERATOR**

**CAPACITIES**

Total Capacity	16.51 Cu. Ft.
Total Shelf Area	17.5 Sq. Ft.

**INTERIOR CONVENIENCES**

PureAdvantage™ Water Filtration System**	Yes
PureAdvantage™ Air Filter	Yes
SpillSafe™ Sliding Glass Shelves	3
Fixed Glass Shelf	1
Smooth-Glide™ Full-Extension Crispers	2
Smooth-Glide™ Full-Extension Deli Drawer	1
3-Position Adjustable Crisper Dividers	2 per Crisper
Clear Dairy Door	1
Clear 1-Gallon Removable Door Bin	1
Clear 2-Liter Adjustable Door Bin	4
Clear Tall Bottle Retainer	1
Clear Door Bin Snuggler	1
Dual 40W Short Blue Tinted Interior Light	Yes
Transition Lighting	Yes
Mid-Level Lighting (2 - 25W Short Blue Tinted)	Yes
Dynamic Cool™ Digital Temperature Control System	Yes
Door Closer	Yes

**SPECIFICATIONS**

Product Height w/ 4" Riser***	68-5/8"
Width	32"
Depth (Including Door)	26-3/4" min.
Depth (with Door Open 90°)	57-1/4" min.
Product Weight	253 Lbs. approx.
Shipping Weight	280 Lbs. approx.
UPC (0-12505-)	22475-1

**OPTIONS**

All-Refrigerator Unit Trim Kit***	Part # SRRRSRKIT
All-Freezer/All-Refrigerator Trim Kit***	Part # DUORSRKIT

\*\* Filtration for ice maker water located in refrigerator unit.

\*\*\* When ordering for All-Refrigerator Unit (E32AR75FPS) specify part # SRRRSRKIT or for All-Freezer/All-Refrigerator Units (E32AF75FPS/E32AR75FPS) specify part # DUORSRKIT which includes 4" riser with leveling system and vented trim kit.

NOTE: Always consult local and/or national electric codes. Refer to Product Installation Guide for detailed installation instructions on the web at [electroluxusa.com](http://electroluxusa.com).

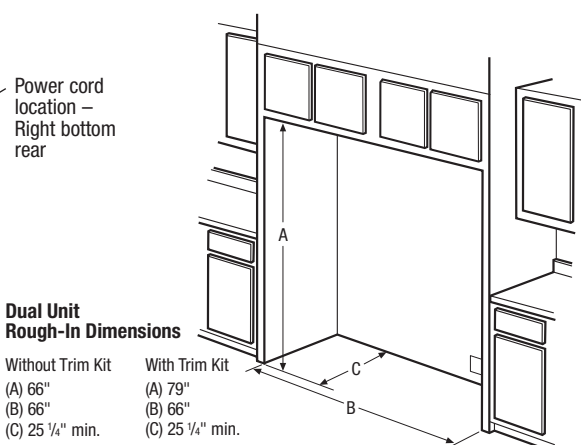
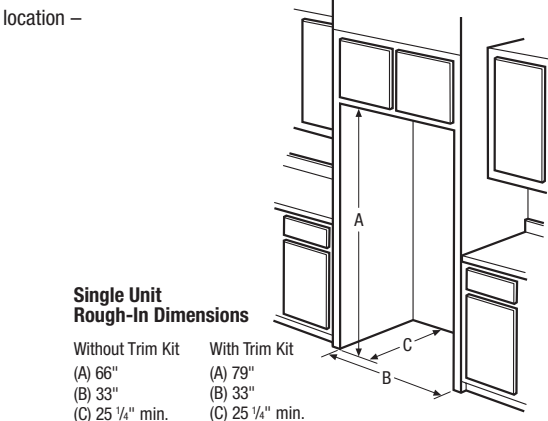
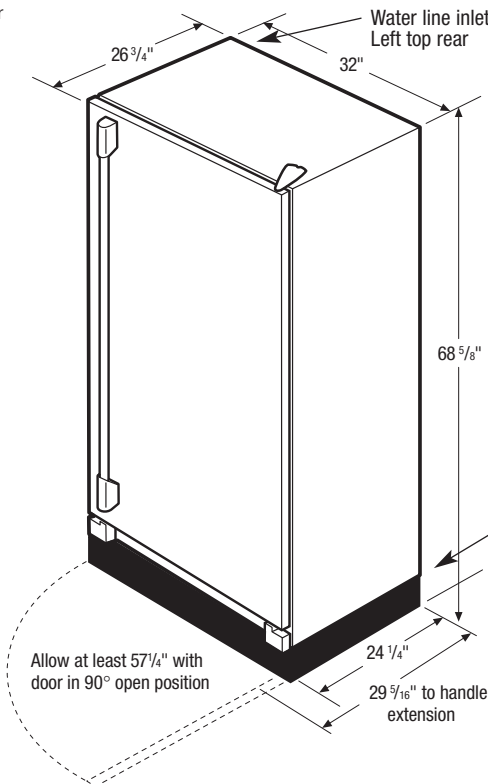

USA • 250 Bobby Jones Expressway • Augusta, GA 30907  
1-877-4electrolux (1-877-435-3287) • [electroluxusa.com](http://electroluxusa.com)

CANADA • 5855 Terry Fox Way • Mississauga, ON L5V 3E4  
1-800-668-4606 • [electroluxca.com](http://electroluxca.com)